

48" 3-POINT HITCH POST HOLE DIGGER

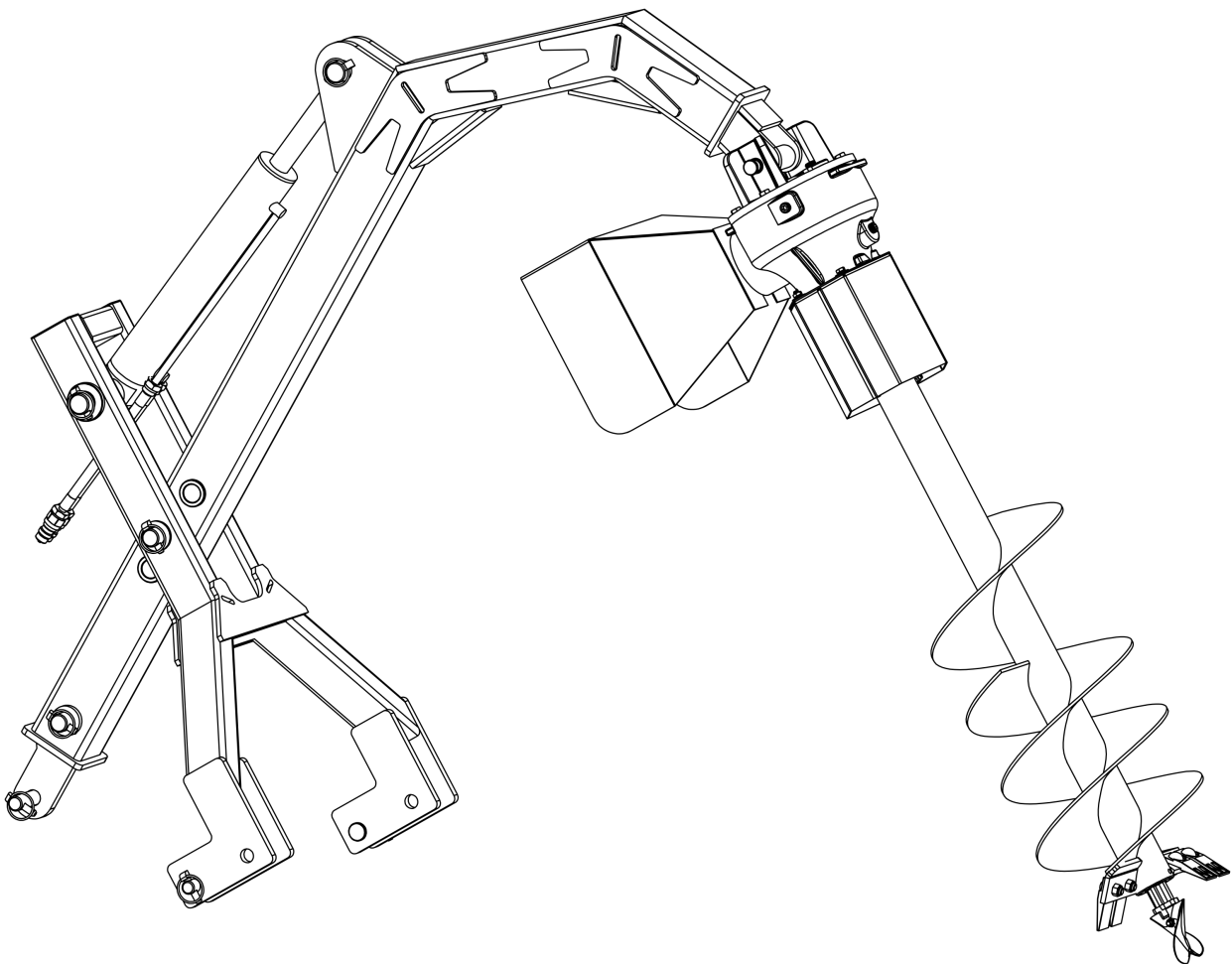

⚠ WARNING

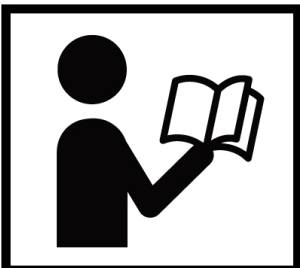

- Please read and understand the product manual completely before assembly
- Check against the parts list to make sure all parts are received
- Wear proper safety goggles or other protective gears while in assembly
- Do not return the product to dealer. They are not equipped to handle your requests.

Missing parts or questions on assembly?

Please call: 1-877-761-2819 or email: cs@tmgindustrial.com

TABLE OF CONTENTS

SAFETY INSTRUCTIONS.....	3
PARTS DESCRIPTION AND FUNCTION.....	5
PRODUCTS SPECIFICATIONS.....	6
PRODUCTS SAFETY DECALS.....	6
UNPACKING & ASSEMBLY.....	7
CONNECTING TRACTOR.....	15
OPERATING ESSENTIALS.....	19
MAINTENANCE SCHEDULE.....	21
TROUBLESHOOTING.....	21
EXPLODED VIEW & PARTS LIST.....	22

SAFETY INSTRUCTIONS

Safety First

You are responsible for the safe operation and maintenance of your post hole digger. You must ensure that you and anyone else who is going to operate, maintain or work around the post hole digger is familiar with the operating and maintenance procedures and related SAFETY information contained in this manual. This manual will take you step-by-step through your working day and alert you to all good safety practices that should be adhered to while operating the Post hole digger.

Remember, you are the key to safety. Good safety practices not only protect you but also the people around you. Make these practices a working part of your safety program. Be certain that EVERYONE operating this equipment is familiar with the recommended operating and maintenance procedures and follows all the safety precautions. Most accidents can be prevented. Do not risk injury or death by ignoring good safety practices.

1. Post hole digger owners must give operating instructions to operators or employees before allowing them to operate the machine.
2. The most important safety feature on this equipment is a SAFE operator. It is the operator's responsibility to read and understand ALL Safety and Operating instructions in the manual and to follow these. All accidents can be avoided.
3. A person who has not read and understood all operating and safety instructions is not qualified to operate the machine. An untrained operator jeopardies himself and bystanders to possible serious injury or death.
4. Do not modify the equipment in any way. Unauthorized modification may weaken the function and/or safety and could affect the life of the equipment.
5. Think SAFETY! Work SAFELY!

General Safety

1. The post hole diggers are designed and manufactured only for the purpose of boring holes in earth and clay materials. Under no circumstances should they be used for any other purpose.
2. Before using the post hole digger, carefully read and ensure you understand the contents of this Safety Operator's Manual and the contents of the Operators Manual for the associated tractor, including all the relevant safety instructions.
3. Never allow an improperly trained person, child or anyone who is not familiar with the safety rules and operating instructions to attach or operate the post hole digger.
4. Do not leave the tractor seat or allow any person within ten meters of the post hole digger while it is in operation. Serious personal injury or death may result if any attempt is made to assist the digger operation by hand.
5. Do not operate the digger on steep hillsides.
6. Do not operate the digger with any person within ten meters of the machine.
7. Wear ear protection when operating the post hole digger.
8. Refer to the tractor operators manual for safe working loads, including any counter-weighting that may be required to balance the weight of the post hole digger.
9. Before operating the post hole digger, check all the pins, bolts and connection to ensure they are all securely in place. Replace any damaged or worn parts immediately.
10. Never perform service or maintenance while the PTO is engaged, or the tractor engine is on.
11. Check the gearbox oil level and safety clutch adjustment before using the post hole digger.
12. Ensure that there are no underground electrical cables, telephone cables, gas, water, sewerage or drainage pipes in the area to be drilled. If in doubt about any of the above do not start digging until the situation have been fully investigated and it is safe to begin.
13. Exercise extreme care when operating in wet or slippery conditions, or on sloping or uneven terrain. Allow for the effect that the weight of the post hole digger has on the tractor's stability. Refer to the tractors operating and safety instructions.
14. When using the post hole digger it is most important that all the safety guards are fully maintained, in place and operating correctly.
15. Always operate the post hole digger from the tractor seat.
16. Never clear earth away from the auger whilst it is operating.
17. Never allow a person to pull down on the digger boom or attach any type of counterweight to the boom to increase penetration.
18. Before dismounting from the tractor or allowing any person to approach the post hole digger, disengage the PTO, switch off the tractor engine and apply the parking brake.

19. Ensure the tractor engine is switched off and the parking brake is applied before performing any inspection or maintenance on the digger. If it is necessary to raise the machine for such work ensure it is properly supported. Do not rely on the tractor hydraulics for support.
20. Never allow any person to ride on the post hole digger or the tractor when the digger is attached.
21. Never use alcoholic beverages or drugs which can hinder alertness or coordination while operating this equipment. Consult your doctor about operating this machine while taking prescription medications. Review the safety instructions with all users annually.
22. Ensure maintenance is carried out regularly by a qualified person. This is particularly important on moving parts such as the P.T.O. If wearing parts are not properly maintained, driven parts can fly off at high speed causing damage to the machine, operator and bystanders.

Storage Safety

1. Store the machine in an area away from human activity.
2. Do not permit children to play on or around the stored machine.
3. Store the machine in a dry, level area.
4. Clean grease and oil as required and protect it from the elements.

Maintenance Safety

1. Good maintenance is your responsibility. Poor maintenance is an invitation to trouble.
2. Follow good shop practices.
3. Keep service area clean and dry.
4. Be sure electrical outlets and tools are properly grounded.
5. Use adequate light for the job at hand.
6. Make sure there is plenty of ventilation. Never operate the engine in a closed building. The exhaust fumes may cause asphyxiation.
7. Before working on this machine, shut off the engine, set the brakes, and remove the ignition key.
8. Never work under equipment unless it is secured by a mechanical stand.
9. Use personal protection devices such as eye, hand and hearing protectors, when performing any service or maintenance work. Use heavy gloves when handling blades.
10. Only use genuine parts for service and maintenance.
11. A fire extinguisher and first aid kit should be kept readily accessible while performing maintenance on this equipment.
12. Periodically tighten all bolts, nuts and screws and check that all pins are properly installed to ensure unit is in a safe condition.
13. When completing a maintenance or service function, make sure all safety shields and devices are installed before placing machine in service.

PARTS DESCRIPTION AND FUNCTION

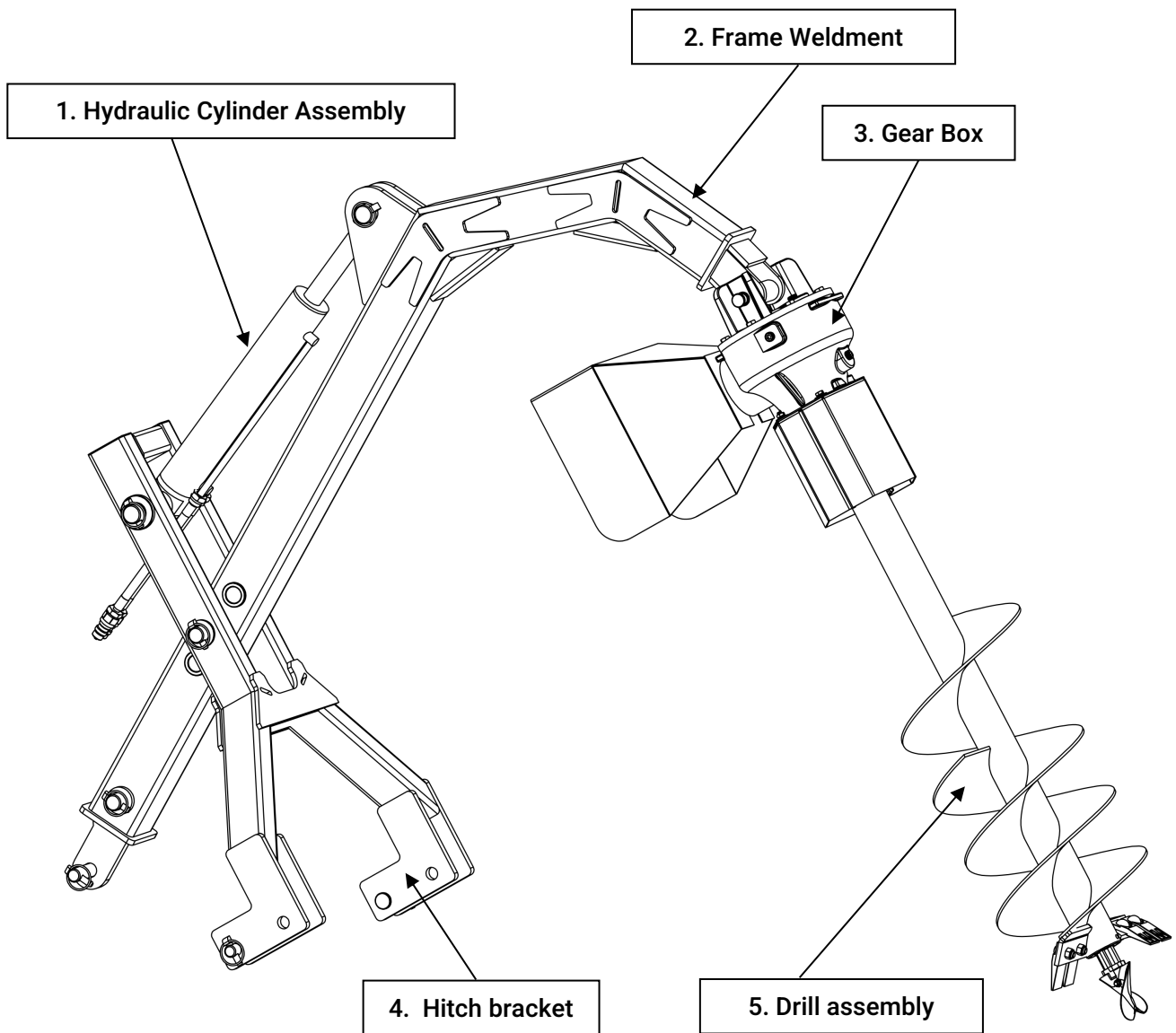

<p>1. Hydraulic Cylinder Adjust the position.</p>	<p>4. Hitch Bracket Connect tractor.</p>
<p>2. Frame Weldment Support the product.</p>	<p>5. Drill Assembly Drill hole.</p>
<p>3. Gear Box (Slip Clutch optional) Through the driver chain transmit power from gearbox to auger.</p>	

PRODUCTS SPECIFICATIONS

Model No	TMG-TPD12
Auger diameter	12"
Max. auger depth	48"
Output bore	2"
Tractors horsepower	35-65hp
3-point linkage	CAT 1 & CAT 2
Length	1770mm
Width	790mm
Weight	215mm
Boom Size	100×100mm
Gearbox	60HP
PTO Safety	Yes-Protective Cover

PRODUCTS SAFETY DECALS

CAUTION

FILL GEARBOX WITH SAE 90 GEAR LUBE

Gearbox is shipped without oil.
Oil must be added before operation.

TMG-ATTA-2023

⚠ DANGER

ROTATING DRIVELINE SHAFT KEEP AWAY



TO PREVENT SERIOUS INJURY AND DEATH

- Keep all guards in place when operating.
- Operate only at 540 RPM.
- Keep hands, feet, hair and clothing away from moving parts.
- Keep U-joint angles equal and as small as possible.
- Do not exceed driveline manufacturers recommended operating length.

TMG-MACH-4042

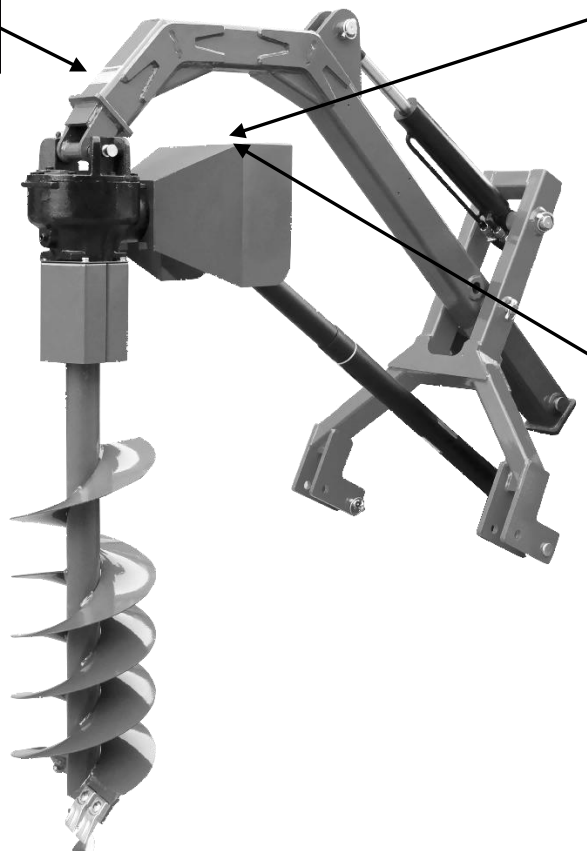

TMG-ATTA-2021

UNPACKING & ASSEMBLY

1. After unpacking, check the following components

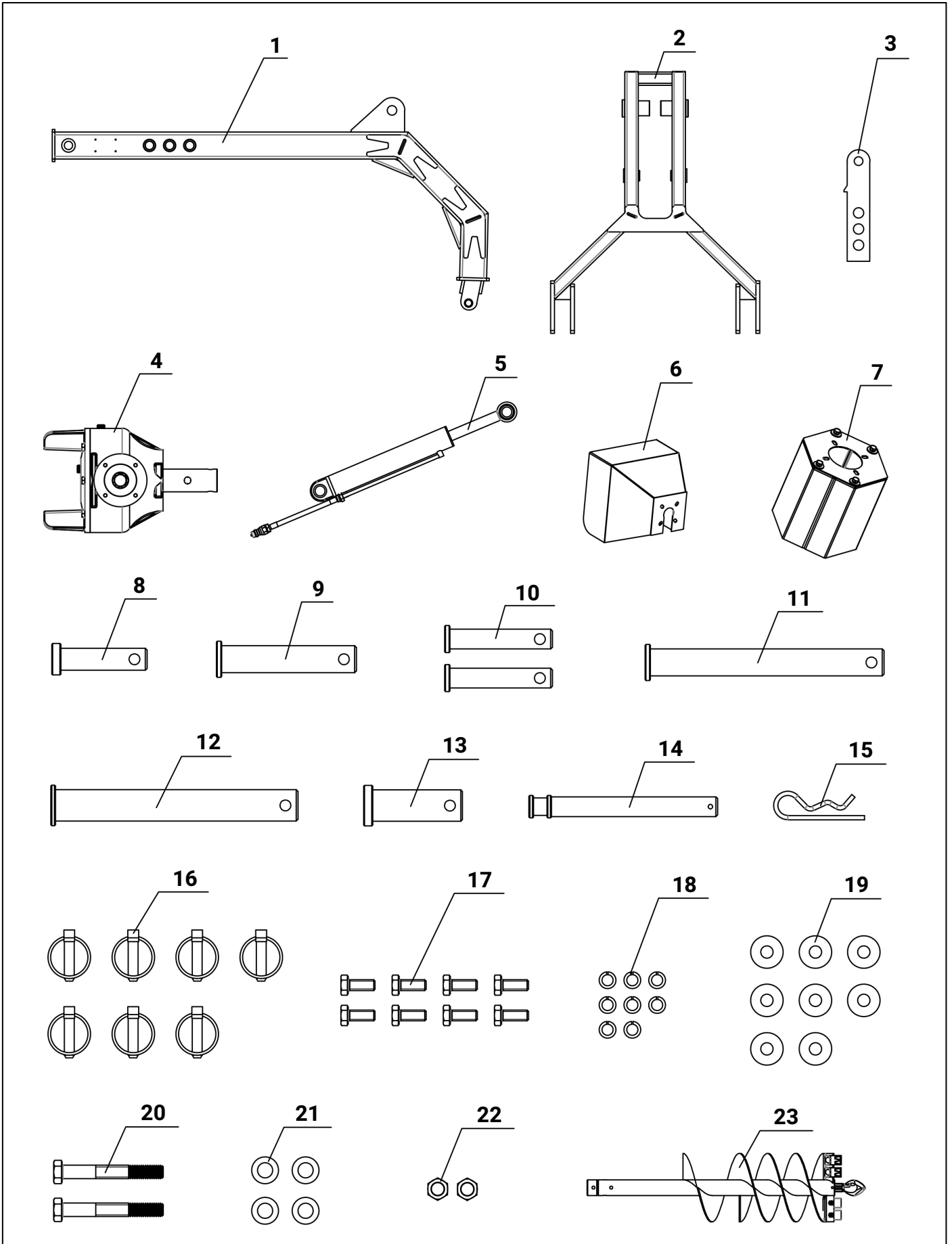

NO.	DESCRIPTION	QTY	NO.	DESCRIPTION	QTY
1	Frame weldment	1	13	Connecting pin 35x100	1
2	Hitch bracket	1	14	Gearbox connecting shaft 22x185	1
3	Upper suspension plate	1	15	R Pin 4	1
4	Gearbox	1	16	Pin 12	7
5	Hydraulic cylinder assembly	1	17	Full-thread hexagon bolts M8x20	8
6	Gearbox protective hood	1	18	Spring washer Ø8	8
7	Drilling bit safety cover	1	19	Large plain washer	8
8	Connecting pin 24.5x96	1	20	Hexagon head bolts M12x90	2
9	Adjusting plate shaft 30x150	1	21	Plain washer Ø12	4
10	Hitch pin-lower 22x144	2	22	Lock nut M12	2
11	Hitch connecting pin 30x260	1	23	Drill assembly	1
12	Connecting shaft 35x270	1			

*.All numbers are not part numbers in the drawings. For correct part numbers, see explosive diagram.

TOOLS FOR INSTALLATION				
NO	DESCRIPTION	SPECIFICATION	CONDITIONS OF USE	QTY
1	Open end wrench	10/13/18	M6, M8, M12 bolt tightening	1
2	Air gun	1280t	Tighten the bolt with the corresponding socket instead of the wrench	1
3	Hammer			1
4	Torque wrench	10-220N·m	Measuring torque	1

After the parts are confirmed to be correct and the tools for installation are ready, start the assembly. The specific operation steps are described below.

2. Install suspension components

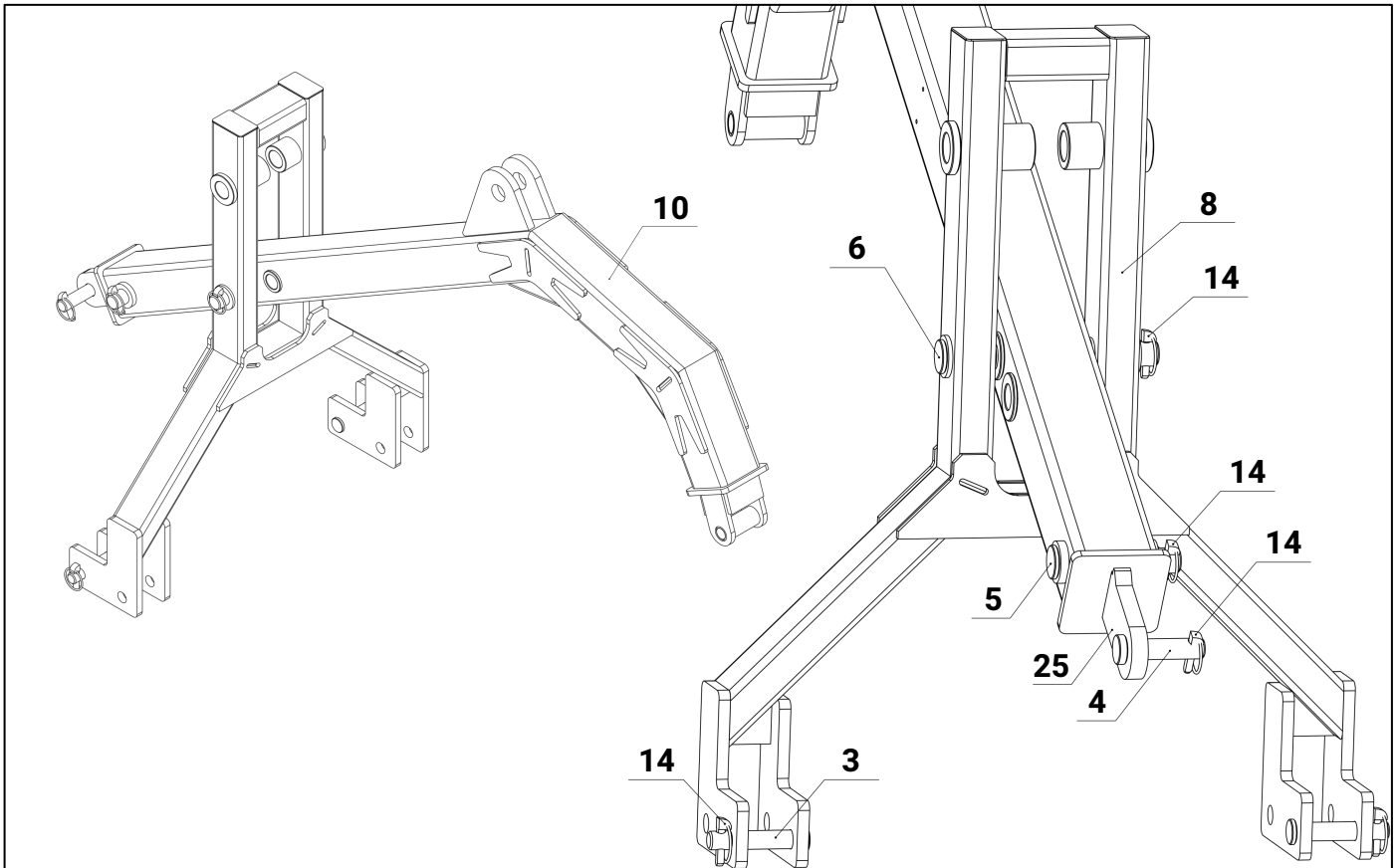

Installation steps:

1. Place the UPPER SUSPENSION PLATE (25) and the FRAME WELDMENT (10) as shown in the figure above, align the mounting holes, connect them in series with the ADJUSTING PLATE SHAFT (5), and install the lock pin (14) to fix it. The other CONNECTING SHAFTS (4) and locking pins (14) are installed in cooperation with the ADJUSTING PLATE SHAFT (5).
2. Place the upper lifting FRAME WELDMENT (10) and the HITCH BRACKET (8) as shown in the figure above, align the mounting holes, connect them in series with the HITCH CONNECTING PIN (6), and install the lock pin (14) to fix it. (When installing, it is recommended to install from the side, and use a shelf to support the parts 5 to prevent safety accidents)
3. Place the HITCH PIN-LOWER (3) through the HITCH BRACKET (8) as shown in the figure above, and install the lock pin (14) to fix it.

PART NO.	DESCRIPTION	QTY
3	Hitch pin-lower 22x114	2
4	Connecting pin 24.5x96	1
5	Adjusting plate shaft 30x150	1
6	Hitch connecting pin 30x260	1
8	Hitch bracket	1
10	Frame weldment	1
14	Pin 12	5
25	Upper suspension plate	1

3. Install the cylinder assembly

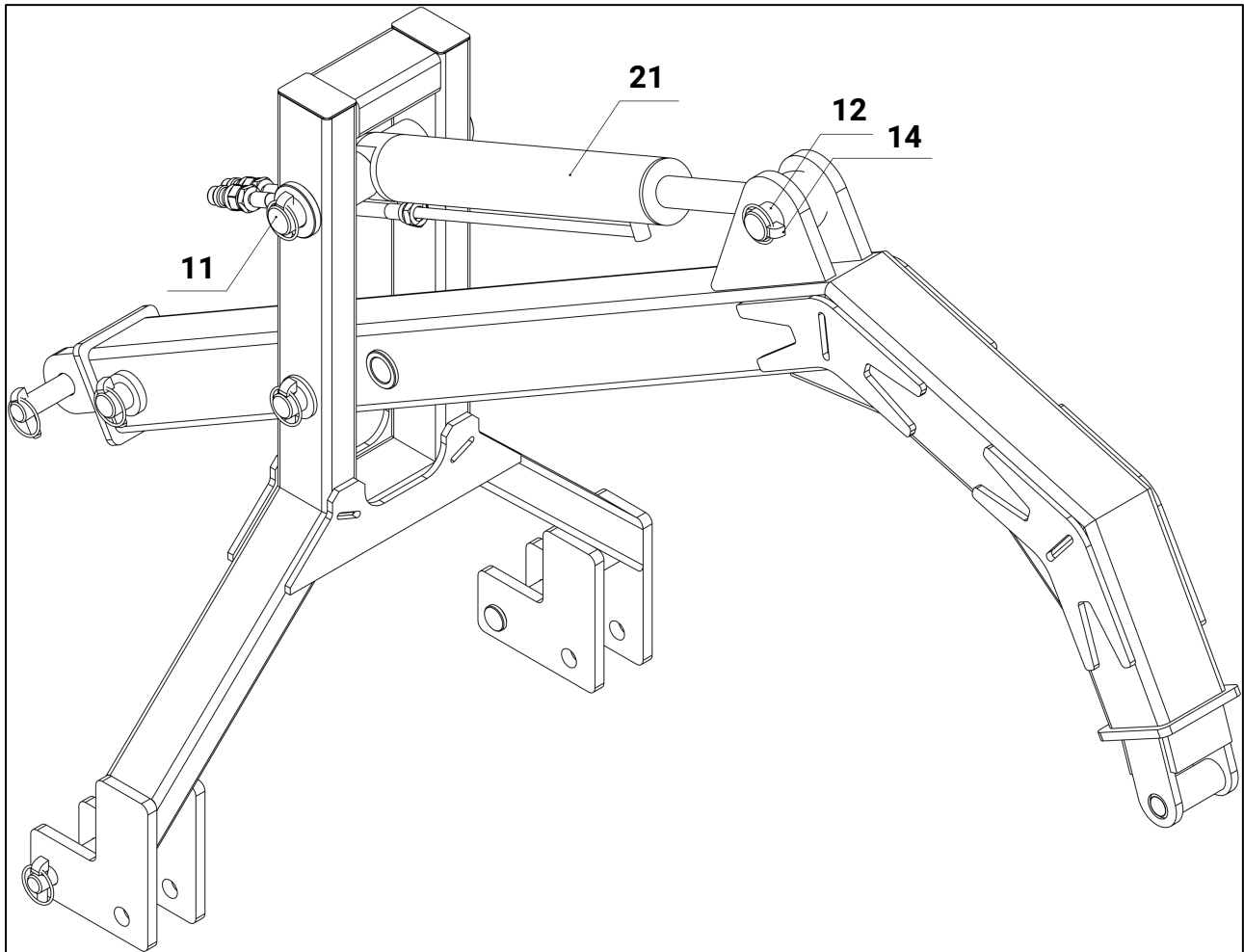

Installation steps:

1. Place the HYDRAULIC CYLINDER ASSEMBLY (21) in the position as shown in the figure above, pass through the pins on both sides, pass through the upper lifting frame welding part and the suspension welding part respectively, connect them in series with the cylinder, and pass through the CONNECTING SHAFT (11) and CONNECTING PIN (12) fixed.

PART NO.	DESCRIPTION	QTY
11	Connecting shaft 35x270	1
12	Connecting pin 35x100	1
14	Pin 12	2
21	Hydraulic cylinder assembly	1

4. Install the gearbox

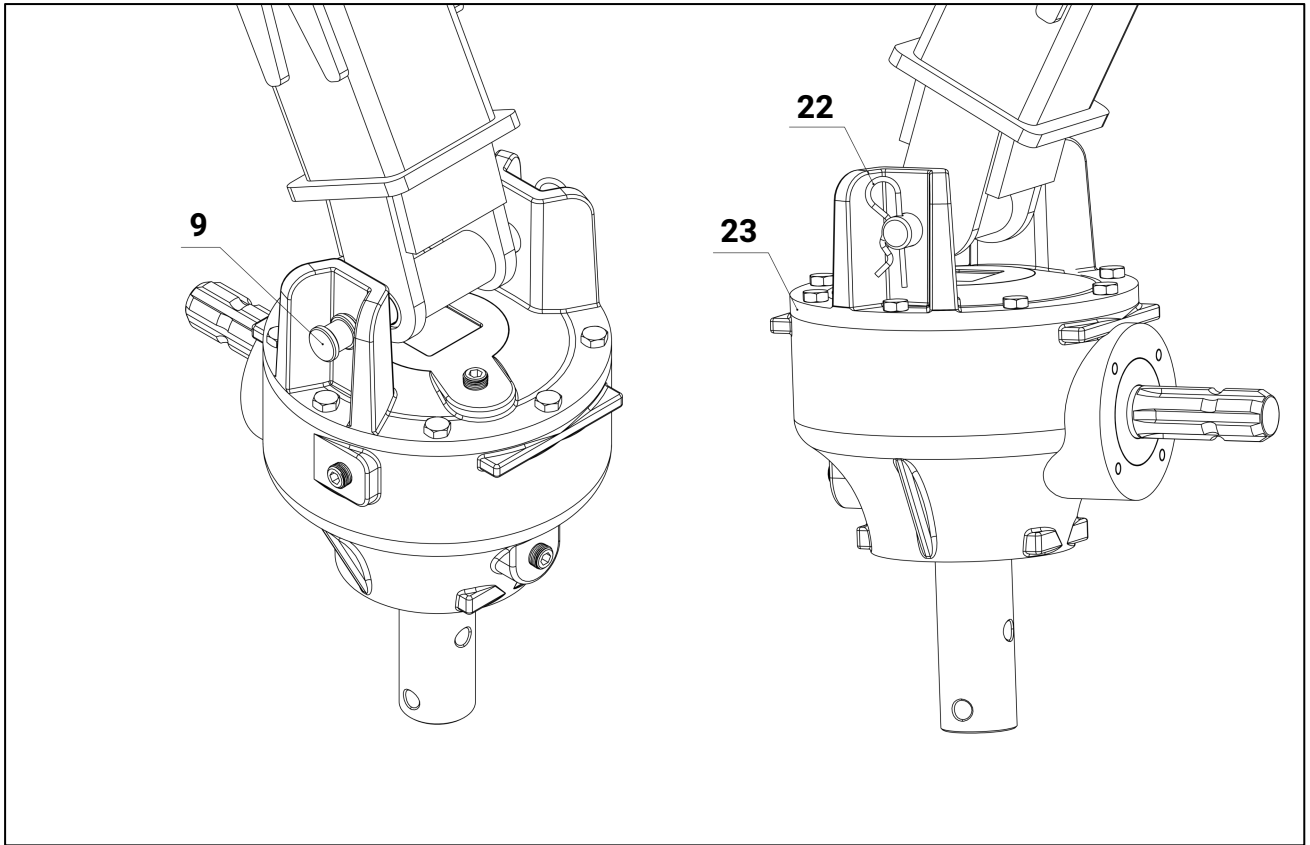

Installation steps:

Place the GEAR BOX (23) in the position shown in the figure above, align the mounting holes on the lifting frame, insert the GEARBOX CONNECTING SHAFT (9), and fix it with R PIN (22).

PART NO.	DESCRIPTION	QTY
9	Gearbox connecting shaft 22x185	1
22	R Pin 4	1
23	Gear box	1

5. Install the gearbox guard

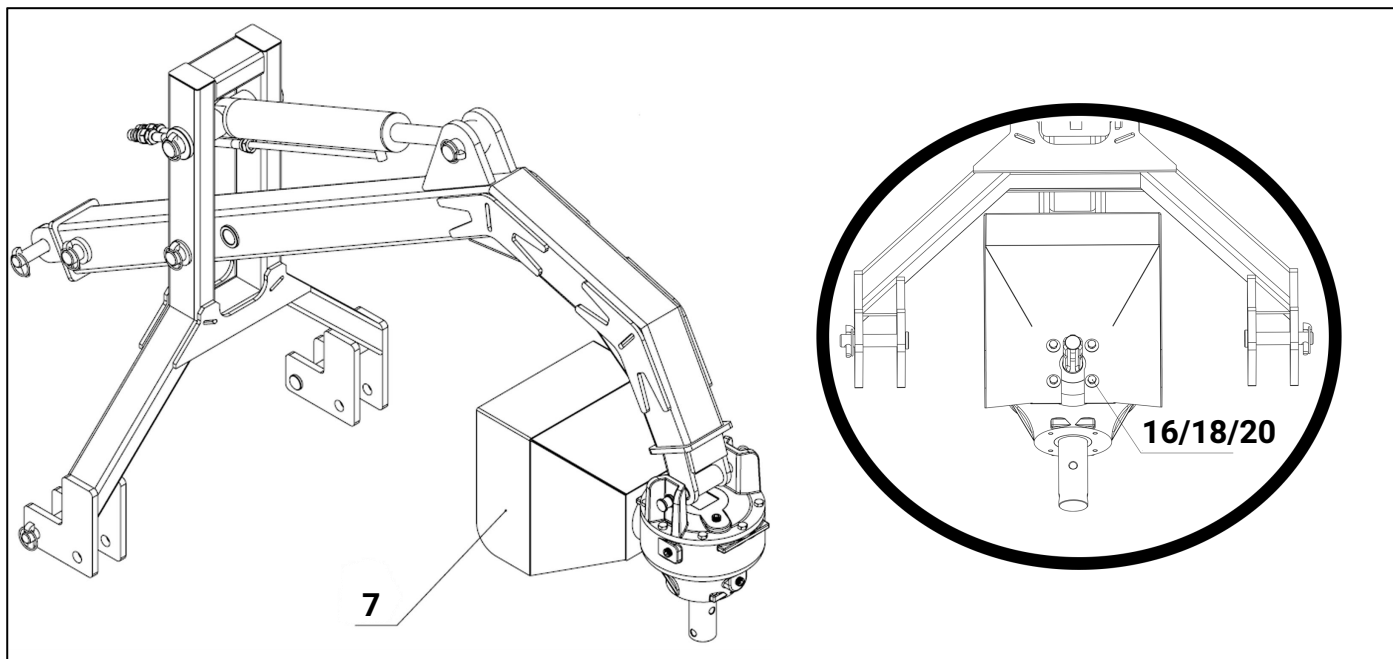

Installation steps:

Place the GEARBOX PROTECTIVE COVER (7) in the position shown in the figure above, install the PLAIN WASHER (20), SPRING WASHER (20), and BOLT (16) in sequence, and fasten it.

Importance: All bolts are locked in place without shaking.

NOTE: M8 Torque is 22~30 N·m

! **WARNING:** Once the assembly bolts are not fastened in place, there will be abnormal noises when the machine is working.

PART NO.	DESCRIPTION	QTY
7	Gearbox protective hood	1
16	Full-thread hexagon bolts M8×20	4
18	Spring washer Ø8	4
20	Large plain washer Ø8	4

6. Install the drill guard

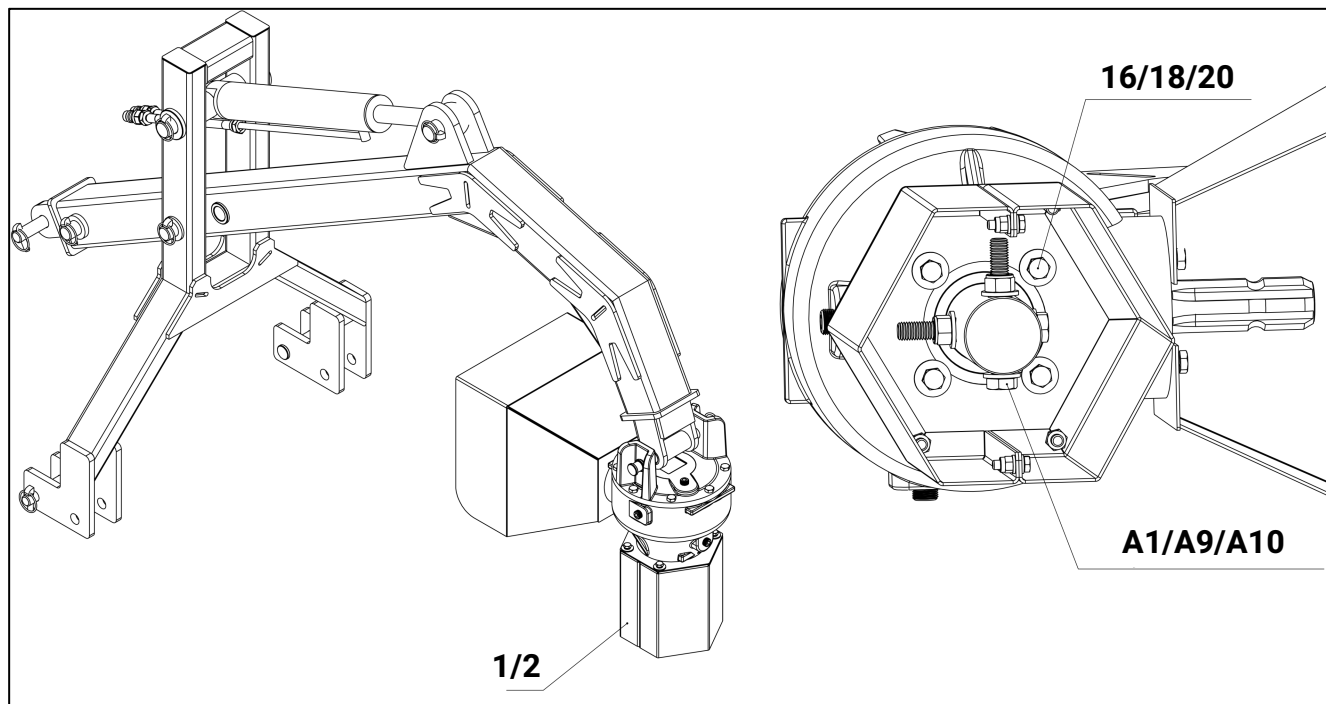

Installation steps:

1. Place the PRE-ASSEMBLED DRILLING BIT SAFETY COVER (1,2) in the position shown in the figure above, and fasten it on the gear box with SPRING WASHER (18), PLAIN WASHER (20) and BOLTS (16).

2. BOLTS(B10), PLAIN WASHER(B9) and LOCKNUT (B1) are used to fix the drill bit of the hole puncher. Connect the optional drill bit to the gear box.

Importance: All bolts are locked in place without shaking.

NOTE: M8、M12 torque is 22~30 N·m、78~104 N·m.

⚠ WARNING: Once the assembly bolts are not fastened in place, there will be abnormal noises when the machine is working.

PART NO.	DESCRIPTION	QTY
1	Drilling bit safety cover	1
2	Drilling bit guard	2
16	Full-thread hexagon bolts M8×20	4
18	Spring washer Ø8	4
20	Large plain washer Ø8	4
A1	Lock nut M12	2
A9	Plain washer 12	4
A10	Hexagon head bolts M12×90	2

7. Installing the drill bit assembly

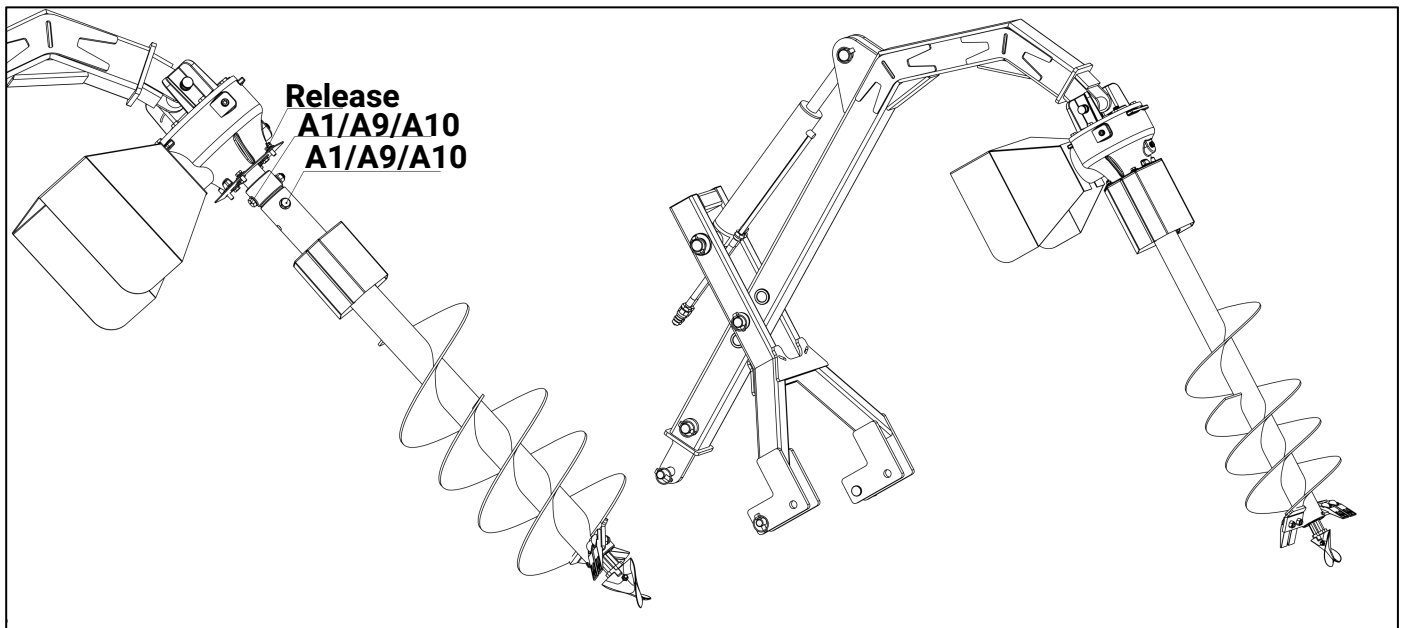

Installation steps:

1. First loosen the bolts on the drill bit guard, remove the drill bit guard.
2. Install the DRILL BIT ASSEMBLY on the gearbox, align the mounting holes on the gearbox, install the BOLTS (A10), PLAIN WASHERS (A9) and tighten the NUT (A1).
3. Finally reinstall the removed bit guard.

Importance: All bolts are locked in place without shaking.

NOTE: M12 torque is 78~104 N·m.



WARNING: Once the assembly bolts are not fastened in place, there will be abnormal noises when the machine is working.

PART NO.	DESCRIPTION	QTY
A1	Lock nut M12	2
A9	Plain washer Ø12	4
A10	Full-thread hexagon bolts M12×90	2

CONNECTING TRACTOR

1. Three-point linkage



WARNING !

In the process of connection, when the tractor is moving, if there is people between the tractor and working machine, it may cause injury accident. Be sure no people stand between the tractor and working machine during the tractor moving.

LOWER LIFTING PIN TYPES	
TMG-TPD12	CAT1 &CAT2

2. Connection and adjustment



CAUTION ! Make sure the tractor is fixed in the process of connection

- Start the tractor engine, tractor and machine head lower link under suspension corresponds to the position of the pin, rewind, stop, stop the engine, put up parking stalls.
- Connect Left towing arm, the left arm on the tractor towing the working machine is left hanging inserted pin, the locking detent. Right arm pulling the same way.
- Adjust the towing arms in the same height, as shown below:

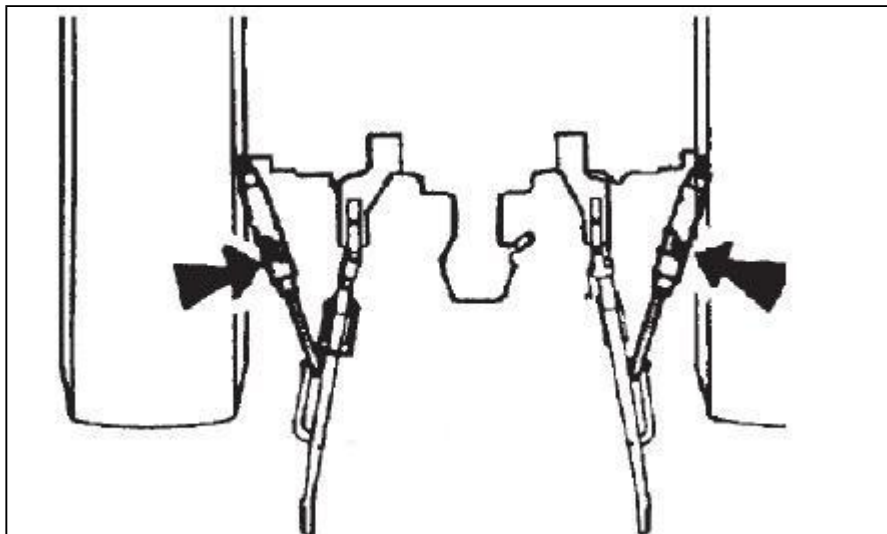

If the magnitude of the tractor towing arms is too narrow, adjust the left suspension pin inward as below:

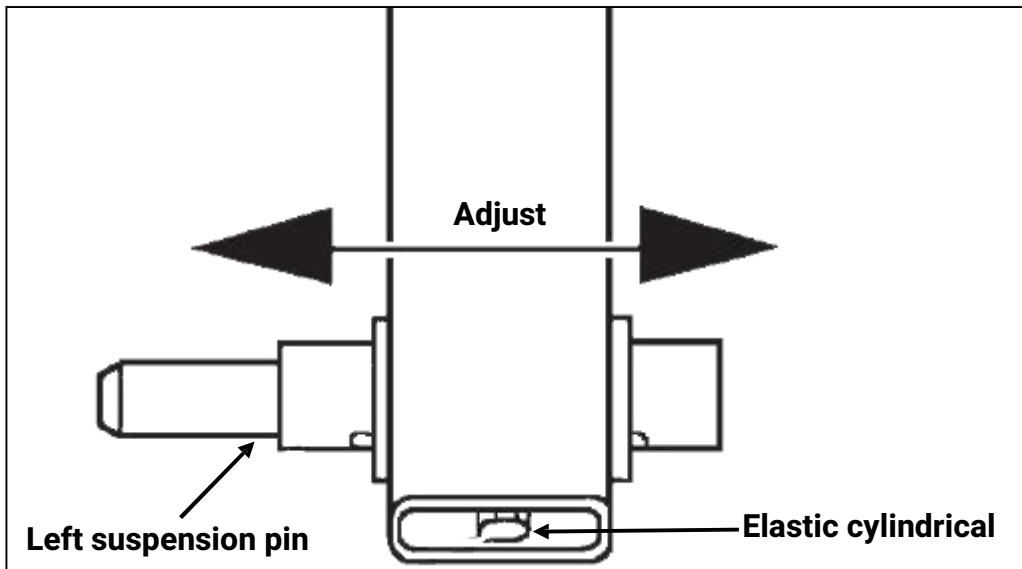

d. Adjust angle, to obtain the most appropriate cutting angle, adjust the upon 3-point linkage suspension to ensure the suitable cutting angle.

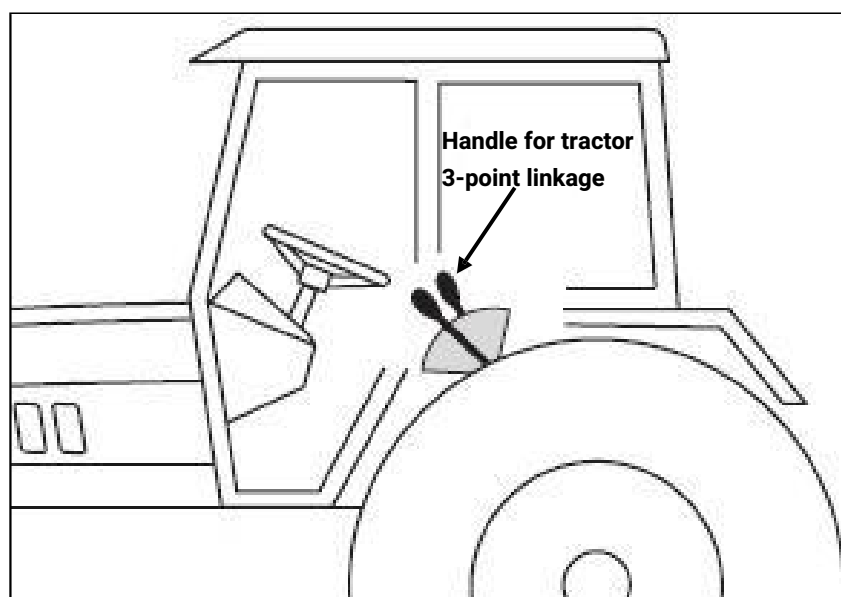
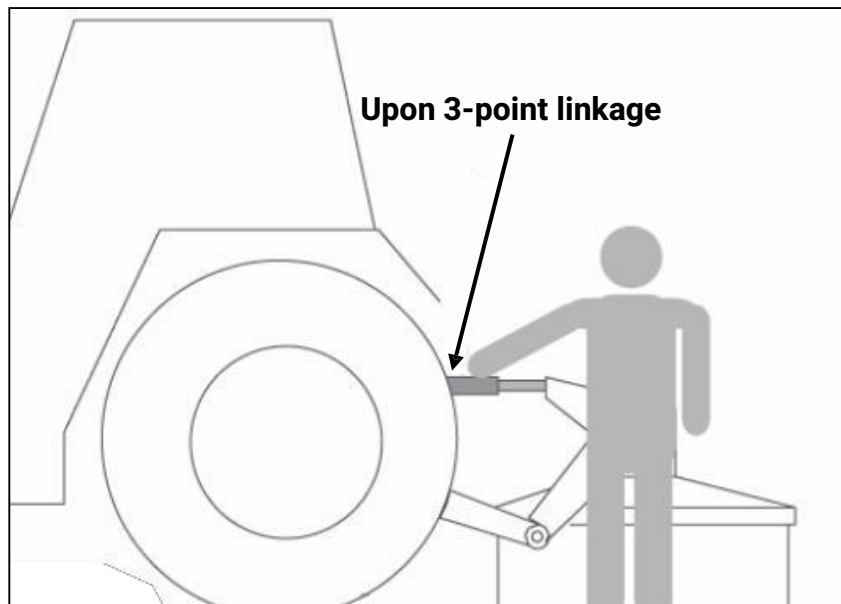

3. PTO installation



DANGER !

- If you use no plastic cover to protect the coupling, it is possible to be involved in the occurrence of injuries. Do not use no plastic casing coupling.
- If you use damaged couplings, injuries may occur entangled. Couplings if damaged, replace it immediately. Please check if coupling have damage before using.
- When connected to the tractor and rotary hoe, as a third party do not pay attention, inadvertently let the power output shaft rotation, injuries may occur, after you cut off the power and stop the tractor engine PTO can be connected to the tractor.

a. Confirm coupling length

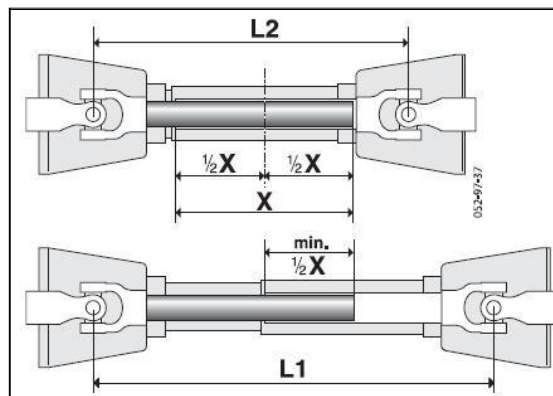

The minimum overlap of inner and outer coupling tube $1/2X$ size should be 220mm, if the size less than 100mm, please change the coupling

L1: The maximum length of connection to the tractor.

L2: The minimum length of the connection to the tractor X: The overlap length.

b. The connection of coupling

1. Coupling connect to the rotary hoe end

Coupling with keyway end connect to the rotary hoe input shaft until the lock pin is exposed to in the original location.

2. Fixed coupling plastic cover

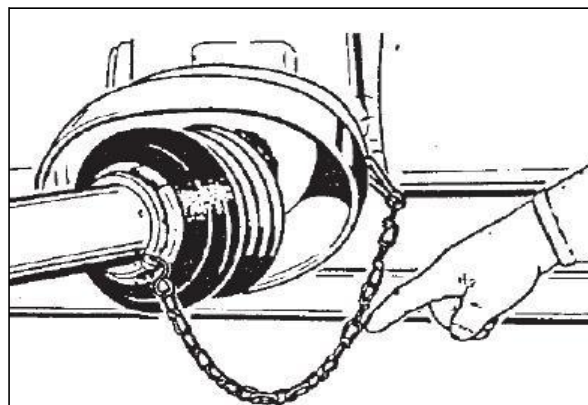

- 3. After connection, fixed the chain to prevent the plastic cover rotation
- 4. Max rotation angle of coupling

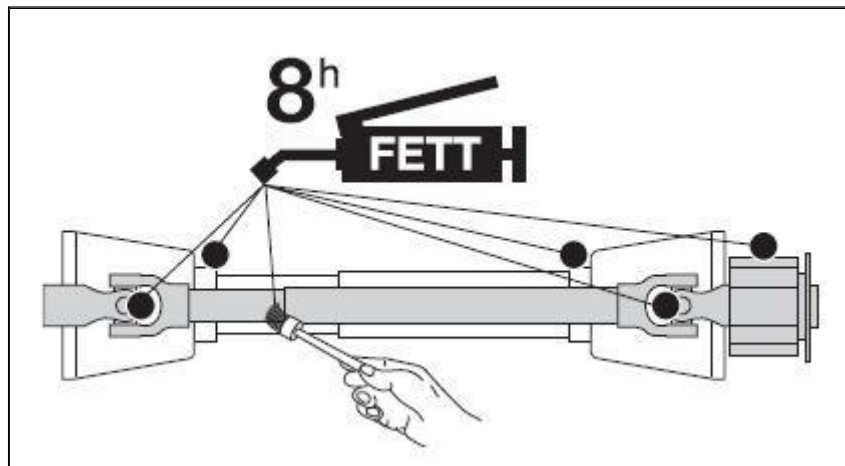

! NOTED !

If the shaft beyond its maximum operating angle of rotation at work, there will be unexpected injury accident. Be sure to fix the tractor three-point suspension before use.

4. Coupling lubrication and maintenance

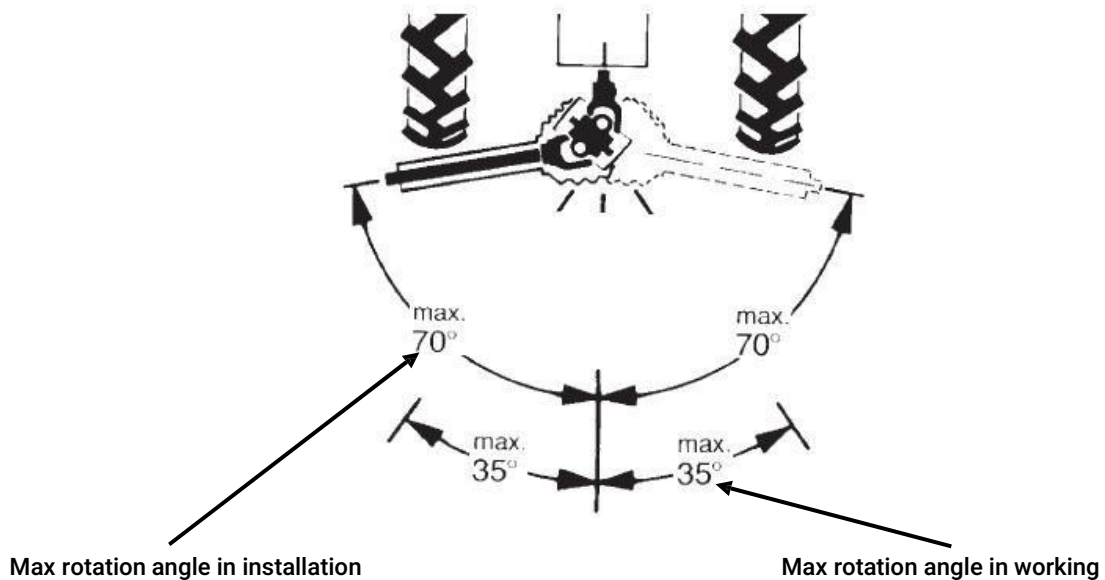

Proper grease lubrication and maintenance will greatly enhance the transmission efficiency of the tractor. After eight hours of continuous operation coupling, check above the pointed position should be oiling and lubrication.

OPERATING ESSENTIALS

ASSEMBLY

Attaching to the Tractor

Standard Model

1. Attach the main support boom to the top link of the tractor with a cat 1 top link pin.
2. Connect the 'A' frame to the lower link arms of the tractor with cat 1 lower link pins.
3. Position and connect the top of the 'A' frame with the outer pivot hole (pivot hole furthest from the tractor) under the main boom.
4. Using the hydraulic linkage of the tractor, check the range of movement by raising and lowering the boom. Moving the pivot pin closer to the tractor will increase the height the boom will lift.
5. With the boom positioned at a convenient height, attach the gear box (with the input shaft facing the tractor) to the boom by aligning the holes and inserting the mounting pin.
6. Check the length of the PTO drive shaft by separating the telescopic shaft and attaching one section to the tractor PTO and the other to the digger gear box. Hold both sections together and parallel. Lower the main boom so the the gearbox input stub is horizontal with the PTO output stub. Ensure the PTO shaft has a clearance of at least 150mm. Repeat the process at the maximum lift height of the boom. Ensure the PTO shafts has at least 300mm overlap. This operation will determine the correct operating length of the drive shaft. The shaft may need to be cut to size.
7. Connect the auger to the output shaft of the gear box with the two shear pins. Tighten the nuts securely.
8. Connect the drive shaft to the gear box and other end to the tractor PTO ensuring correct alignment and seating of the locking pin.
9. Raise and lower the linkage carefully to ensure sufficient ground clearance can be maintained. Adjust the 'sway chains' to provide minimal side-ways movement.

Hydraulic Model

First fit up

1. Fit the post hole digger boom and 'A' frame to the three point linkage with the ram disconnected at the ram end.
2. Select the 'A' frame and boom pivot position to suit the tractor. You will need the boom to raise high enough to clear the surface with the auger tip by 100 – 150mm, and lower enough to dig the required depth.
3. Fit the auger and lower the auger tip to rest firmly on the ground.
4. Place the linkage lever in the full down position and do not move it at any time.
5. Check the PTO shaft for length as described in above. Cut the shaft to suit as necessary following the safety precautions described earlier.
6. Pin the hydraulic ram to the mount on the boom. Ensure all pins are locked securely.

The hydraulic remote lever is the only control now used to raise and lower the auger

Attaching the Assembled Digger to the Tractor

1. Position the digger with the PTO shaft removed and gearbox and auger on the ground behind the boom.
2. Back the tractor into position and lower the linkage. Connect the tractor lower linkage to the 'A' frame.
3. Align and connect the main boom top link mount to the tractor.
4. Lift the main boom with the hydraulics to the right height and fit the gear box and auger to the end of the boom.
5. Fit the PTO shaft.
6. Make sure the safety guards are in place and properly secured.

Changing Auger Teeth and Pilot

When worn the teeth and/or pilot bit on the auger should be replaced to maintain good digging performance. Two types of teeth and pilots are available. Standard teeth and standard pilot are used for normal ground conditions. Hard-faced teeth and hard-faced pilot can be fitted for drilling in rocky ground. Both types of teeth and pilots will fit the augers.

The teeth are located in the socket of the auger head by their 'U' shaped profile and are held in place by a rubber retainer which is wedged between the tooth and the socket. To remove the tooth, place a small punch on the rear corner and strike it sharply with a hammer to drive it out of the socket, refer to the diagram below.

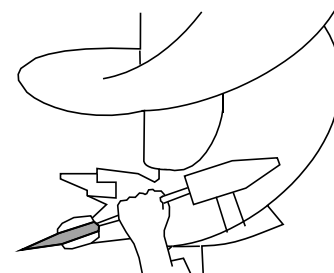

CAUTION: Always wear eye protection when installing and removing teeth

Changing the Auger

All augers are the same length and are attached in the same way by two shear bolts through the gearbox output shaft.

To remove the auger, raise the boom to allow the auger to hang vertically then lower until the end of the auger is about 100mm above the ground. Stop the tractor engine and apply the parking brake. Remove the two attaching bolts from the upper end of the auger and pull down so that it slides off the gearbox shaft. If the auger is tight on the shaft loosen it by sharply striking the auger tube with a hammer where it overlaps the gearbox shaft. If it is necessary to strike the auger longitudinally on the flighting to drive it off the shaft, first place a piece of timber on the flighting to avoid damage.

Clean and lightly grease the gearbox output shaft and the inner tube of the new auger. Align the bolt holes and slide the auger onto the gearbox shaft. Install and securely tighten the two shear bolts.

Detaching the Digger from the Tractor

Raise the boom to allow the auger to hang vertically then lower it until the end rests on the ground. Stop the tractor engine and apply the parking brake. Remove the PTO shaft. Move the tractor slowly forward whilst lowering the boom until the digger gearbox rests on the ground. Stop the tractor and fully lower the linkage. Disconnect the upper linkage pin then the lower pins. It may be necessary to use a hoist to take the weight of the digger.

Alternatively the digger can be removed with the PTO still attached to the gearbox by drilling the auger into the ground, to hold it in an upright position.

General Operation

Standard Model

Before operating the digger for the first time carry out the lubrication checks. Check the gearbox oil level and grease the PTO drive shaft universal joints and telescoping shaft. Read all the safety information contained in this manual and on the decals attached to the machine. Carefully inspect the area to be dug.

In very good digging conditions the auger can sometimes cork-screw into the ground without breaking out the soil. Avoid this happening by periodically lifting the auger with the three point linkage enough to break the drilled ground. In most instances this will not be required.

Always operate the digger from the tractor seat. Under no circumstances stand or allow any other person to stand near the auger when it is revolving. Never clear earth or allow any other person to clear earth from the auger while it is revolving. No other person should be within ten meters of the machine while it is in operation.

Position the tractor with the auger hanging vertical and touching the ground at the spot where the hole is to be dug. Use the tractor linkage to raise or lower the auger. Move the tractor backwards and forwards and adjust the three point linkage vertical arm to get the auger perpendicular

Set the tractor engine speed to a fast idle so that the auger will revolve in the range of 50 to 100 rpm. The most appropriate auger speed will depend upon the available tractor power, the diameter of the auger and the ground conditions. The larger the diameter of the auger the slower the auger should rotate.

Engage the PTO drive and allow the action of the auger to penetrate the surface. Slowly lower the tractor linkage to follow the penetration of the auger.

At every 300 to 500mm of depth lift the boom to spin the earth off the auger flighting, and then continue drilling. When lifting, do not lift the auger clear of the hole as the auger will angle back and may not track back into the hole. At stages of drilling you may need to move the tractor forward or backward to keep the auger vertical and compensate for the arc of the boom.

If the safety clutch slips reduce the 'down pressure' and if necessary inspect the hole for obstructions.

Before inspecting the hole or when the required depth has been reached, raise the auger from the hole and disengage the PTO drive. Move the tractor away from the hole and lower the auger so that the end rests on the ground.

Stop the tractor engine, apply the parking brake and dismount to inspect the hole.

When transporting the post hole digger, raise the auger and travel slowly at a speed that is safe for the particular ground or road conditions. If traveling on a public road, ensure that the tractor complies with the local regulations.

Hydraulic Model

Follow all safety precautions. To use the hydraulic post hole digger effectively, some experience with remote hydraulics is helpful.

1. Position the auger where the hole is to be dug and ensure it is vertical
2. Engage the PTO in 540 rpm and select mid throttle.

3. Lower the auger slowly using the hydraulics until it starts to dig. Continue to lower the auger slowly ensuring it does not corkscrew into the ground. It may be necessary to clear the auger by raising it from time to time, only using the remote control lever. When the required depth is reached, lift the auger with the hydraulic remotes and move to the next hole.

MAINTENANCE SCHEDULE

Inspection unit list	8hrs/ Daily			40hrs/Weekly			Annually		
Lubricate PTO Shaft	✓			✓			✓		
Check Gear Box Oil Level				✓			✓		
Clean Machine							✓		
Lubricate and Clean PTO Shaft Cover							✓		

TROUBLESHOOTING

PROBLEM	PROBABLE CAUSE	SOLUTION
Abnormal sound or abnormal	1. Incorrect oil 2. Gear, bearing damage 3. Overload or soil hardness is high	Change Oil Replace damaged Parts Readjust tillage depth
Coupling abnormal sound	1. No Oil 2. Overload angle is too large	Add lubrication Proper use according to Manual

EXPLODED VIEW & PARTS LIST

1. Explosion diagram of main components

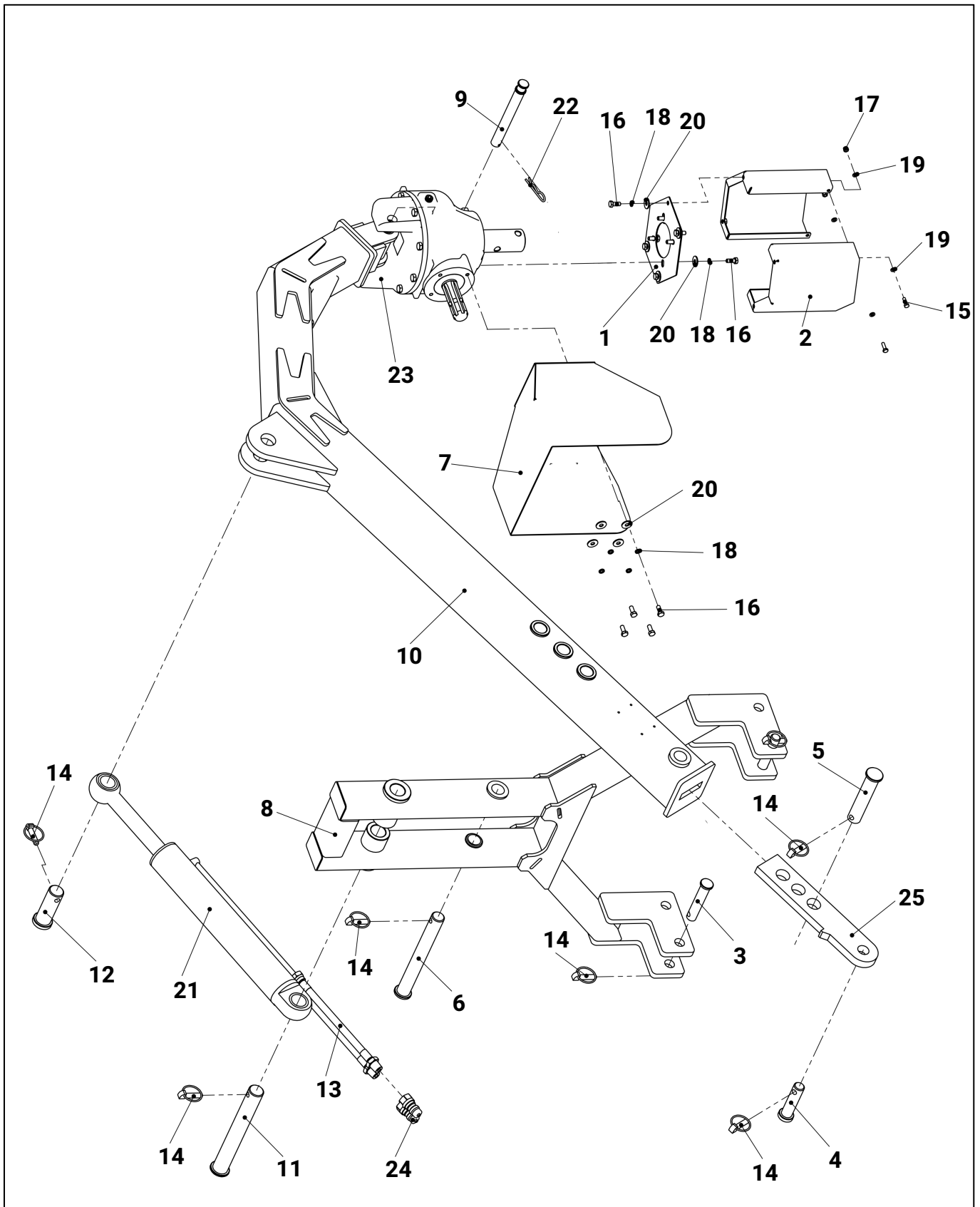

PARTS LIST

PART NO.	DESCRIPTION	QTY	PART NO.	DESCRIPTION	QTY
1	Drill bit safety cover	1	14	Pin 12	7
2	Drill bit guard	2	15	Full-thread hexagon bolts M6×20	2
3	Hitch pin-lower 22x114	2	16	Full-thread hexagon bolts M8×20	12
4	Connecting pin 24.5x96	1	17	Lock nut M6	2
5	Adjusting plate shaft 30x150	1	18	Spring washer Ø8	12
6	Hitch connecting pin 30x260	1	19	Plain washer Ø6	4
7	Gearbox protective hood	1	20	Large plain washer Ø8	12
8	Hitch bracket	1	21	Hydraulic cylinder assembly	1
9	Gearbox connecting shaft 22x185	1	22	R Pin 4	1
10	Frame weldment	1	23	Gearbox	1
11	Connecting shaft 35x270	1	24	Hollow bolt	2
12	Connecting pin 35x100	1	25	Upper suspension plate	1
13	Hydraulic hose 3/8"x63", 1/2 NPT fitting	2			

2. Explosion diagram of drill assembly

PARTS LIST

PART NO.	DESCRIPTION	QTY	PART NO.	DESCRIPTION	QTY
A1	Lock nut M12	10	A6	Full-thread hexagon bolts M12×30	8
A2	Lock nut M8	1	A7	Blade	8
A3	Heel block	8	A8	12" drilling bit	1
A4	Full-thread hexagon bolts M8×35	1	A9	Plain washer Ø12	4
A5	Drilling bit blade	1	A10	Full-thread hexagon bolts M12×90	2

