

# 70" 3-POINT HITCH BRUSH MULCHER



## ⚠ WARNING



- Please read and understand the product manual completely before assembly
- Check against the parts list to make sure all parts are received
- Wear proper safety goggles or other protective gears while in assembly
- Do not return the product to dealer. They are not equipped to handle your requests.

Missing parts or have questions on assembly?

Please call: 1-877-761-2819 or email: [cs@tmgindustrial.com](mailto:cs@tmgindustrial.com)

<b>1. SAFTY.....</b>	<b>2</b>
1.1 General.....	2
1.2 Safety Instructions.....	2
1.3 TMG Brush Mulcher – Description and Applications.....	3
1.4 Operational Safety The Work Area.....	4
1.5 The Hazard Zone.....	4
1.6 Dangerous Locations.....	5
1.7 Urban Precautions.....	6
<b>2. OPERATIONAL SAFETY/ THE OPERATOR.....</b>	<b>6</b>
2.1 Sound Levels/ Hearing Protection.....	6
2.2 Dust Protection.....	7
2.3 Protection from Flying or Falling Objects.....	7
2.4 Avoid Power Lines.....	7
2.5 Operator Protection.....	7
2.6 Stopping the Rotor Before Exiting the Carrier.....	9
<b>3. CARRIER VEHICLE PREPARATION/MAINTENANCE.....</b>	<b>9</b>
3.1 Shielding.....	9
3.2 Carrier Vehicle Preparation/Maintenance.....	10
3.3 Carrier Clean-up.....	10
<b>4. POLICING THE WORK AREA.....</b>	<b>11</b>
4.1 Avoid Metal and Wire.....	11
4.2 Use Caution with Stringy Vegetation.....	11
4.3 Avoid Plastics.....	11
4.4 Depth Shoe Adjustment.....	11
<b>5. MULCHER OPERATION.....</b>	<b>12</b>
5.1 Push working.....	12
5.3 Stump Grinding.....	19
5.4 Finishing the Work.....	20
5.5 Hydraulic Push Bar Operation (Optional Equipment).....	20
5.6 Trap Door.....	21
<b>6. PREVENTATIVE MAINTENANCE.....</b>	<b>22</b>
6.1 SAFETY FIRST.....	22
6.2 Rotor Power Belts.....	22
6.3 Lubrication Points.....	26
6.4 Tighten All Bolts.....	27
<b>7. ROTOR MAINTENANCE.....</b>	<b>27</b>
7.1 Visual Inspection.....	27
7.2 Tool Replacement.....	28
<b>8. DISPOSAL PROCEDURE.....</b>	<b>28</b>
<b>9. PART LIST.....</b>	<b>28</b>

## **WARNING**

1. Read manual before operating .
2. Do not operate or perform maintenance on your brush mulcher without reading and understanding this entire manual first.
3. If this manual is lost or if you have any questions, contact TMG or your dealer before you proceed.

### **UNDERSTAND THE WRITTEN INSTRUCTIONS, RULES AND SAFETY PRECAUTIONS**

1. The written instructions rules and safety precautions are outlined in this operation and safety manual.
2. Check the rules and regulations at your location. The rules include employer's work safety regulations and local government guidelines' and restrictions for safe operation of the equipment.

### **PERFORM APPLICATION TRAINING WITH OPERATOR**

1. Conduct felid instruction with a trained Operator. Application training should include complete vehicle safety, operation training, complete mulching safety and application training.
2. Know and understand your work conditions; hazards should be reviewed and terrain surveyed at this time as well as with all new work sites.
3. Verify that the machine is in complete safe working order and prepared for your application.

## **1. SAFETY**

### **1.1 GENERAL**

The forestry mulcher is designed to process heavy organic material such as branches, stumps, heavy timber and brush.

### **1.2 SAFETY INSTRUCTIONS**

#### **SAFETY ALERT SYMBOL**

This symbol is used throughout this manual to call attention to safety procedures.

#### **DANGER**

The word DANGER indicates an immediate hazardous situation, which if not avoided, will result in death or serious injury.

#### **WARNING**

The word WARNING indicates a potentially hazardous situation which, if not avoided, could result in death or serious injury.

#### **CAUTION**

The word CAUTION preceded with a safety alert symbol indicates a potentially hazardous situation which, if not avoided, may result in minor or moderate injury

#### **NOTICE**

Indicates information or a company policy that relates directly or indirectly to the safety off personnel or protection of property.

#### **SAFETY FIRST**

With any piece of equipment, new or used, the most important part of its operation is safety! We encourages you and your employees to familiarize yourselves with your new equipment and to stress safe operation!!

#### **PRIOR TO OPERATION:**

- Read the owner's manual in its entirety and follow all safety procedures.
- Check all grease points per the owner's manual 3. Inspect all fasteners for tightness with power off.

- Manually turn rotor to inspect tool bolts with engine off.
- Check gearbox oil (PTO models) for proper level per owner is manual.

Obey all safety labels on the forestry mulcher. They are provided for your protection. If any labels are removed, damaged, or made unreadable in any way, call your dealer for a replacement.

### 1.3 TMG BRUSH MULCHER – DESCRIPTION AND APPLICATIONS

Forestry	Orchard Removal	Land Clearing
Transfer Stations	Stump Grinding	ROW Maintenance
Yard Waste Process	Forest Fire Prevention	Brush and Slash Piles

The versatile forestry mulcher was designed for shredding woody materials. The forestry mulcher excels at processing yard waste, land preparation and slash reduction. It has multiple uses for farmers, parks, golf courses, loggers, land clearing companies, ranchers, foresters and silviculturists.

The mulcher fixed tools are designed to withstand daily brush shredding, land clearing and stump grinding operations.

The forestry mulch shreds material into a fine particle size by going over the shredded material until the desired texture is achieved.

If left on the ground the shredded material is beneficial to the soil. On steep slopes the output from the mulcher is ideal for interim erosion control.

### 1.4 OPERATIONAL SAFETY THE WORK AREA:

For the sake of this manual, the front of the mulcher is the side with the rotor exposed. The rear has deflection chains. For crawlers and rubber tire machines, when the mulcher is mounted on the front of the machine, the front of the mulcher is facing the same forward direction. If mounted on the rear, the front of the mulcher is facing away from the rear of the carrier. Mounting for excavators and other boom-type installations may vary but references to the front and rear of the mulcher remain the same.

### 1.5 THE HAZARD ZONE

Flying debris or objects and falling objects can cause serious injury or death. Improper operation and failure to follow safety precautions can cause serious injury or death. All personnel must be clear of the hazard zone while the mulcher is in operation.

The Hazard Zone is illustrated in Figure 1.1 on the following page. All personnel should be kept clear of this zone while the mulcher is operating.

The shaded area in the hazard zone must be considered off limits to all individuals! The operator should follow the precautions below before and during operation of the mulcher.

#### HAZARD ZONE PRECAUTIONS

It is the operators responsibility to ensure that no one enters the hazard zone! Warn all persons in the area of the hazard zone.

Stay alert for outsiders entering the work area who may not be aware of the hazard zone.

Land clearing operations generally involve other machinery and people on the site.

Maintain an awareness of all working traffic within 150 ft (45 m) (to each side) and 300 ft (90 m) (in front and behind) of the mulcher operation.

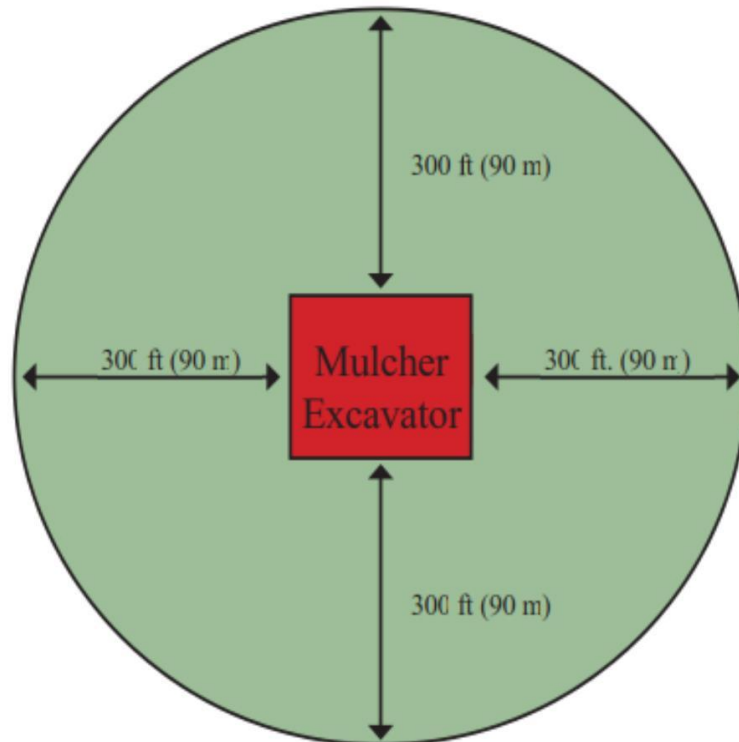

## 1.6 DANGEROUS LOCATIONS

### **Flying debris or objects and falling objects can cause serious injury or death**

Improper operation and failure to follow safety precautions can cause serious injury or death. All personnel must be clear of the hazard zone while the Mulcher is in operation.

DANGER EXISTS MOST PROMINENTLY IN FRONT OF AND BEHIND THE MULCHER.

Pieces of wood and rock can project from the mulcher. This condition is dangerous. This will occur when the mulcher is raised high enough to allow material to escape.

### **FOLLOW THESE PRECAUTIONS:**

1. NEVER allow anyone to enter the Safety Zone of the mulcher while it is in operation.
2. INSPECT the Carrier and mulcher daily for damaged or missing deflection chains and flaps.

### **Be especially careful when:**

When the mulcher is being raised up and out of the material that it is working in.

When the mulcher is lowered into new material.

CLOSE the hydraulic trap door (if equipped) while pull-working to better contain material. This also increases the fineness of the shredded product.

(See section 5.2, Mulcher Operation – Pull-working).

## 1.7 URBAN PRECAUTIONS

A step-up of safety procedures and precautions is required when working:

- Near streets
- Near highways
- In parks, on golf courses or other inhabited areas
- Near buildings

**Establish safety parameters that fit the site:**

String colored warning tape to secure the work area.

Place signs warning of mowing zone (if working alongside of highway) 1,000ft 300m) (minimum) before edge of Hazard Zone is breached.

Utilize a traffic director when the hazard zone impinges on

Pedestrian or vehicular traffic

Erect barriers

## **2. OPERATIONAL SAFETY/ THE OPERATOR**

### **WARNING!**

#### **2.1 SOUND LEVELS/ HEARING PROTECTION**

HEARING PROTECTION MUST



BE USED IN THIS AREA!

#### **2.2 DUST PROTECTION**

Prolonged and excess exposure to dust can cause complications of your Respiratory System. Prolonged and excess exposure to dust can cause chronic and acute health problems.

Utilize a NIOSH approved respirator  
With replaceable filters rated for dust  
Collection.



#### **2.3 PROTECTION FROM FLYING OR FALLING OBJECTS**

BE ALERT of the possibility of projectiles exiting the machine. Falling brush, branches, and trees also present a potential hazard to the operator. As illustrated in Section 1

#### **2.4 AVOID POWER LINES**

Serious injury or death can result from contact with electric lines.  
Never move any part of the equipment or the tree it's carrying,  
closer than 3 meters plus twice the line insulator length to an electric line.  
Use a signal person to guide operator.  
Use shrouds or insulators as necessary.

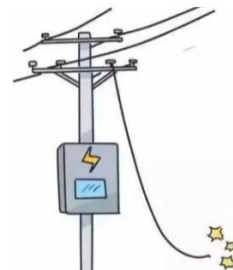

Be aware of the direction that trees are felling! Always direct away from power lines!

#### **2.5 OPERATOR PROTECTION**

**Flying debris or objects and falling objects can cause serious injury or death**

Install minimum of 1/2" thick (1.25cm) Lexan™ Polycarbonate cab windows. Install approved FOPS falling Object Protection.

Replace damaged or missing Polycarbonate windows or falling object protection components.

Improper operation and failure to follow safety precautions can cause serious injury or death. All personnel must be clear of the hazard zone while the mulcher is in operation.

**Take the following precautions!**

The following precautions are recommended for operator protection. Additional guarding may be required to protect the carrier, such as belly pans or skid plates, etc. Always follow safety regulations and certifications for your specific industry. Check with the manufacturer of your carrier for recommended operator protection.

**For PTO Carriers:**

1/2" (1.25cm) thick polycarbonate or equal, should be installed in place of or outside of the cab glass between the operator and the mulcher.

A steel mesh screen of 2" (5cm) maximum openings and 1/4" (6cm) diameter wire is recommended outside of the cab between the mulcher and the operator to protect Polycarbonate from scratches.

**For Forestry Prime Movers with Enclosed Cab:**

1/2" (1.25cm) thick polycarbonate or equal, should be installed in place of or outside of the cab glass between the operator and the mulcher.

A steel mesh screen of 2" (5cm) maximum openings and 1/4" (6cm) diameter wire is recommended outside of the cab between the mulcher and the operator.

**For Excavators and Boom type Carriers with Enclosed Cab:**

Front of cab facing boom should have a 1/2" (1.25cm) thick polycarbonate or equal, should be installed in place of or outside of the cab glass between the operator and the mulcher.

A steel mesh screen of 2" (5cm) maximum openings and 1/4" (.6cm) diameter wire is recommended outside of the cab between the mulcher and the operator to protect Polycarbonate from scratches.

**For Mini-Track Loads and Skid steers:**

1. Do not operate without enclosed cab.
2. Cab door should have a 1/2" (1.25cm) thick polycarbonate or equal, should be installed in place of or outside of the cab glass between the operator and the mulcher.
3. A steel mesh screen of 2" (5cm) maximum openings and 1/4" (6cm) diameter wire is recommended outside of the cab between the mulcher and the operator to protect Polycarbonate from scratches.

**Take the following precautions!**

Make sure that the carrier vehicle has proper protection between the operator and the mulcher. This will protect the operator as well as the carrier control area.

- (2) Wear ANSI approved.
- (3) protective eyewear such as: Safety Glasses, Goggles, Face shield.
- (4) Wear an ANSI approved hard hat.
- (5) Wear appropriate ear protection.
- (6) Steel toe shoes are an excellent safeguard for anyone on or around machinery.

## 2.6 Stopping the Rotor Before Exiting the Carrier

Contact with moving rotor can cause serious injury or death. Do not exit the vehicle before the rotor stops.

To stop rotor:

Lower the engine speed to Idle (2) Shut off the mulcher circuit

Push the rotor into the ground or other debris until rotor stops

If there is no place to stop the rotor, wait for the rotor to stop before exiting the cab.

## 3. CARRIER VEHICLE PREPARATION/MAINTENANCE

### 3.1 SHIELDING

Shielding is essential for protecting the Carrier and the operator.

All parts of the carrier closest to the mulcher are most susceptible to damage.

Use appropriate material as brush guards.

The operator area should be protected as noted in Section 2.5.

Shielding must allow good access to service machine, clean and remove debris.

### 3.2 Carrier Vehicle Preparation/Maintenance

#### AVOID INJURY OR DEATH

**Shut-off the engine. Put carrier in depressurized state.**

Wait until all machine components have completely stopped before touching them.

Use lockout/tagout procedure (29CFR 1910.147) during any inspection or maintenance.

Secure lifting cylinder with locking device before entering a hazardous area.

Insert safety lock before entering a hazardous area.

Attach support before entering a hazardous area.

Refer to the Safety Section in this manual for more information.

#### 3.3 CARRIER CLEAN-UP

Periodic removal of debris and dust from the carrier vehicle is essential to continued successful operation and **FIRE PREVENTION**.

Open all compartments and remove all flammable debris such as leaves, twigs, pine needles, wood chips, dust and any leaking or spilt oil or fuel.

Upon discovery of oil or fuel leaks, repair and clean up immediately. Oil attracts dust and creates a fire hazard by insulating lines causing excess heat generation. Inspect and clean all dust from fittings and lines.

Provisions should be made for removal of shredded wood buildup between hoses lift arms, lines, and other "nooks and crannies."

A blower should be used to knock the dust and wood chips off the entire carrier at least twice per day, wherever permissible by the carrier manufacturer.

Clean the radiator as required to avoid overheating.

Use water only if it can dry thoroughly before operating. Dust clings to anything wet and a wet radiator can quickly restrict air flow.

Contain and dispose of any petro-chemical runoff through a licensed processing facility.



Do not dispose of petro-chemical runoff into municipal waste.

Do not use high pressure washer directly on electrical contacts.

Be careful using high-pressure washers, which may bend and split the radiator fins.

## **4. POLICING THE WORK AREA**

Before starting, a visual survey of the area to be worked is helpful in identifying any undesirable items that may be present. Remove them as much as is practical before proceeding

### **4.1 AVOID METAL AND WIRE**

Metal can break the tools' carbide tips. Wire seeks to wrap itself around the rotor shaft, especially near the bearings. The wire can tighten and squeeze past the grease seals causing BEARING DAMAGE IF NOT REMOVED.

### **4.2 USE CAUTION WITH STRINGY VEGETATION**

Shredding material like Palmetto, Bird of Paradise, and yard waste tied with plastic can damage the rotor bearings. The mulcher readily handles this material but the operator should exercise additional caution while working it.

### **4.3 AVOID PLASTICS**

Hoses, bags, tarps and ropes must be removed as soon as they are seen.

Mattresses, rugs, clothes, and cloth will plug the machine and cause the rotor to stall

Periodical rotor inspection for foreign debris is required.

### **4.4 DEPTH SHOE ADJUSTMENT**

On models equipped with adjustable depth shoes, adjust distance of the mulching rotor to the ground by moving shoes up/down.

Remove bolts from each foot and reposition on the mulcher body as desired.

Adjust up to move cutting action closer to the ground.

Be sure to locate both feet in the same position.

## **5. MULCHER OPERATION**

The following instructions will help to assure that your forestry mulcher is operated safely and effectively. Read this section carefully and use extreme caution at all times.

- Flying debris or objects and falling objects can cause serious injury or death exercise extreme caution to assure that all personnel are outside of the hazard zone as described in section 1.5.

### **5.1 PUSH WORKING**

Raise the head above the work to be done or as high as possible. The hydraulic top link of the three-point hitch carriers or the tilt cylinders of loader arms on most hydraulic carriers are retracted to its innermost position. This rotates the entire machine and trap door upwards to maximize the rotor area to the work. Move the carrier forward to engage the work.

**Position the Mulcher so that:**

- If equipped with a trap door put it in the open position to allow maximum exposure of the mulcher tools to the work.
- Engage the work fully.  
Lower the head as the work allows. When RPM begins to drop move carrier slowly back while continuing to lower the head.
- Rotate the head downward as the head approaches the ground using care not to rotate the head too quickly.

- Gauge carrier speed and shredding depth by monitoring the engine RPM's in response to the mulcher tools contacting and grinding the work. Do not allow the engine to slow below its torque curve or beyond the engines ability to quickly recover when the load is removed.

## **5.2 PULL WORKING**

### **HAZARD ZONE**

Flying debris or objects and falling objects can cause serious injury or death. Before changing direction, make sure that all personnel are outside of the hazard zone.

Now the head is positioned properly for shredding the work you have taken down. A major factor in successful operation is learning how soon to start going back the way you came. It is in this mode that the finish work is performed.

Begin shredding pullback when chains are slightly off the ground and the front corner of the mulcher shoes contact the ground.

Note: for fine grind raise head slightly off ground AFTER contact.

The mulcher is moved slowly back grinding the material repeatedly against the counter combs inside the body.

Closing the trap door (if equipped) will retain as much material as possible within the mulcher shroud for safe operation and maximum shredding.

Just as in the Take Down Mode, work the lift slightly up and down in response to the carriers engine RPM's and proceed in low speed gear.

## **5.3 STUMP GRINDING**

### **Out of Ground (loose) stumps**

The tilted-back cutter head is raised up and slowly brought down to plane a layer off the stump. Raise up and plane down.

- As a general rule, do not rotate the cutter head forward because the rotor might catch the loose stump and eject it towards the tractor.
- Sometimes it is better to dig a hole with the rotor to roll the stump into so that it can be pinned in one place to be ground down.
- Lower the mulcher to keep the stump engaged and pinned to the ground. Proceed grinding downward with the mulcher, s tools climbing up and over the stump.
- Repeat this process as the mulcher works through the stump an inch or two at a time, taking great care not to eject the shrinking stump under the carrier.

### **FIXED (IN GROUND) STUMPS**

- Grinding off stumps still in the ground simply requires the back and-forth motion of the tractor while the cutter head is being incrementally lowered.
- Stump grinding is most effective in the forward direction. This allows the rotor to walk over the stump as it grinds with the added force of gravity and positive kinetic energy in its favor.

### **NOTICE:**

- A rotor that moves back and forth changes the angle of attack, changes the tool arc, has less total friction to overcome, tears the fiber laterally, and helps split the tree fibers horizontally.

## **5.4 FINISHING THE WORK**

Now that the Material has been taken down, shredded and stumps have been removed you can do the finishing grind.

- All final grinding should be done in the backward direction. Raise the head clear of the materials and move

forward to begin each finishing pass.

- Begin shredding pullback when chains are slightly off the ground and the front corner of the mulcher shoes contact the ground.
- The slower the carrier speed, the finer the grind.

#### 5.5 HYDRAULIC PUSH BAR OPERATION (OPTIONAL EQUIPMENT)

##### FOR SMALLER TREES:

The push bar leans small trees over so that when they engage the mulching rotor, they do not fall on the carrier.

##### FOR LARGER TREES:

- Retract the hydraulic top link or hydraulic cylinders of loader arms to rotate the mulcher back far enough so that all the tools contact the tree and begin to cut through it.
- When a majority portion of the trunk has been cut (e.g. 7" (18cm) of a 12" (30cm) tree extend the push bar cylinders to push the tree away from the carrier as the rest of the tree is cut through.

##### THE OPTIONAL RAKE TEETH:

- Rake Teeth attach to the hydraulic tilting push bar (optional).
- Rake teeth are rotated down to near ground level when lowering push bar.
- Rake teeth are helpful when material lies on inaccessible or uneven areas, e.g. slopes, embankments, etc. And pulls it to level ground for shredding.
- Rake teeth can be used to disengage piles of brush, making it possible to cut and build up mulch layers neatly, one layer at a time.

#### 5.6 TRAP DOOR (OPTIONAL EQUIPMENT)

##### THE TRAP DOOR:

1. Opens to maximize exposure of the mulching tools while in the take down mode.
2. Closes to contain the whirling brush within the mulcher shroud for maximized shredding in the pull-working and finishing modes.



Closed Trap Door

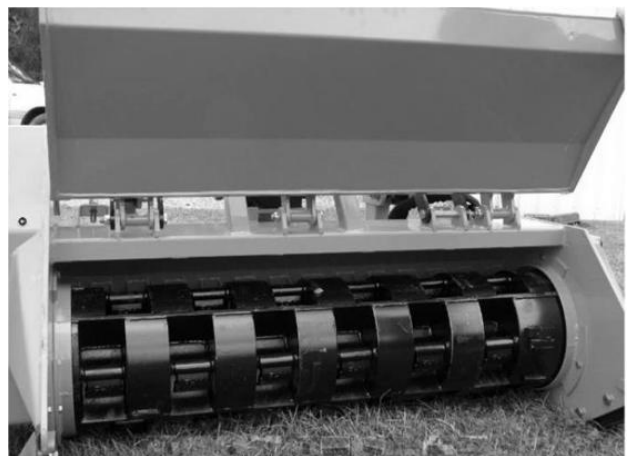

Opened Trap Door

**TRAP DOOR MUST BE OPEN WHEN TAKING DOWN TREES AND HEAVY BRUSH! THE DOOR WILL BE DAMAGED IF RAMMED**

## 6. PREVENTATIVE MAINTENANCE

Proper preventive maintenance will help ensure that the Mulcher will perform to its full capabilities and eliminate unnecessary breakdowns due to neglect.

The manufacturer's warranty is conditional upon following all maintenance recommendations.

### 6.1 SAFETY FIRST

- Dismantle the machine only on flat and firm ground.
- Uncouple the cardan shaft and place it in the holding chain. (On PTO drive machines only.)
- To elevate the rotor above ground level, adjust the depth shoes down or position the depth shoes on firm blocks. This will allow the rotor to be rotated for cleaning, replacing belts and replacing tools. While performing maintenance, only rotate the rotor manually!
- Always double-check the stability of the mulcher before reaching under or into the machine!
- The weight of the mulcher lightens the carriers' rear wheel weight. When transporting the unit, at least 20% of the carrier's unladen weight has to lie on the front axle to assure reliable steering and avoid tipping backwards. Weight the carrier front accordingly.
- Use only original replacement parts for repairs

### 6.2 ROTOR POWER BELTS (THE MULCHING ROTOR IS DRIVEN BY POWER DRIVE BELTS.)

- Shut-off the engine. Put carrier in depressurized state
- Wait until all machine components have completely stopped before touching them.
- Use lockout/tag out procedure (29CFR 1910.147) during any inspection or maintenance.
- Secure lifting cylinder with locking device before getting in hazardous area.
- Insert safety lock before getting in hazardous area.
- Attach support before getting into hazardous area. Refer to the Safety Section in this manual for more information.

### ADJUSTING ROTOR DRIVE BELT TENSION: (SEE FIGURE 6.1)

- After first 8 hours of operation re-tension belts.
- Should be checked every 10-20 working hours and more frequently in the first 24 to 48 hours of operation.
- Remove the inspection plates from the side access panels to check belt tension.
- Open the access doors at the rear of the mulcher to expose the adjustment bolt and fixing screws.

### LOOSEN THE FIXING SCREWS UNTIL THE BEARING HOUSING CAN BE MOVED WITH THE ADJUSTING BOLT.

- Ideal tension is the lowest tension at which the belt will not slip under peak load conditions. Refer to Figure 6.1 for belt deflection at the center of the span between pulleys.
- Over tensioning shortens belt and bearing life.
- Keep belts free from foreign material, which may cause slippage.
- Never apply belt dressing as this will damage the belt and cause early failure.

### WHEN PROPER TENSION IS ACHIEVED:

- Lock the adjusting bolt.
- Tighten the fixing screws.

**TO REPLACE DRIVE BELTS FOLLOW THE SAME PROCEDURE AS STATED ABOVE FOR ADJUSTING BELTS EXCEPT:**

- Remove entire side access panels.
- It is not necessary to remove side inspection plates, which are mounted to the access panels.

**DO NOT OPERATE WITHOUT GUARDS**

**DO NOT OPERATE THE MULCHER WITHOUT ALL GUARDS IN**

**PLACE. SIDE ACCESS PANELS MUST BE RE-INSTALLED PRIOR TO RUNNING! SEE SAFETY PANEL IDENTIFICATION IN SECTION 1.4.**



### **6.3 LUBRICATION POINTS**

#### **NOTICE! LUBRICATION TYPE**

The manufacturer's warranty is conditional upon using a quality #2 lithium based grease.

- Shut-off the engine. Put carrier in depressurized state.

- Wait until all machine components have completely stopped before touching them.
- Use lockout/tag out procedure (29CFR 1910.147) during any inspection or maintenance.
- Secure lifting cylinder with locking device before getting in hazardous area.
- Insert safety lock before getting in hazardous are.
- Attach support before getting into hazardous area. Refer to the Safety Section in this manual for more information.
- Rotor Bearings – Grease Daily. Use 1 pump of grease for each hour of operation. For best results and to ensure long component life grease 4 pumps after every 4 hours of operation.

**NOTICE: IF GREASE IS NOTICED INSIDE**

- The belt housing, decrease
- The frequency of lubrication.
- Drive Shaft Bearing Housing – Every 50 hours (1-2 pumps max).

Open front access panels on each side. Use hand pump only.

Notice: Excess lubrication can elevate the operating temperature of the bearing housing.

**ACCEPTABLE LEVELS AT HOUSING ARE:**

- Minimum- 50% full (Add 1 pump and recheck)
- Maximum 75% at assembly

**OVER LUBRICATING DRIVE BEARING**

**CAUTION**

Over-lubricating sealed drive bearings will cause premature seal failure resulting in bearing failure, premature shaft wear and/or hydraulic motor shaft failure.

**6.4 TIGHTEN ALL BOLTS!**

The mulcher is assembled with superior grade fasteners with locking nuts where applicable and torqued to their proper range. All precautions are taken to keep bolts tight but with the forces exerted by the mulcher the potential for loosening bolts exists.

Go over the machine and check all bolts for tightness after the first 10 hours

Check all bolts daily thereafter

**7. ROTOR MAINTENANCE**

**7.1 VISUAL INSPECTION**

- Safely Position the machine as instructed in Section 6.1 so that the rotor turns freely.

**CHECK THE TOOLS DAILY FOR:**

- Lateral clearance
- Bolt tightness (See model specific parts manual for torque value.
- Condition of carbide tips

After 20 to 40 hours of operation all tools must be checked for proper torque. Failure to check torque after initial 20 to 40 hours can result in tool and tool holder failure.

**Note:** See rotor specific parts manual for torque specifications.

### 7.2 TOOL REPLACEMENT

- Remove fixing bolts
- Remove old tool and insert new tool.
- Torque new fixing bolts and torque to factory specifications (see your specific model parts manual). Use only factory supplied high strength bolts.

### NOTICE!

Always use new hardware to ensure proper torque.

### 8. DISPOSAL PROCEDURE

Do not discard into municipal waste stream.

Disassemble and contain hydraulic components in approve container. Discard through a licensed processing facility.



### 9. PART LIST

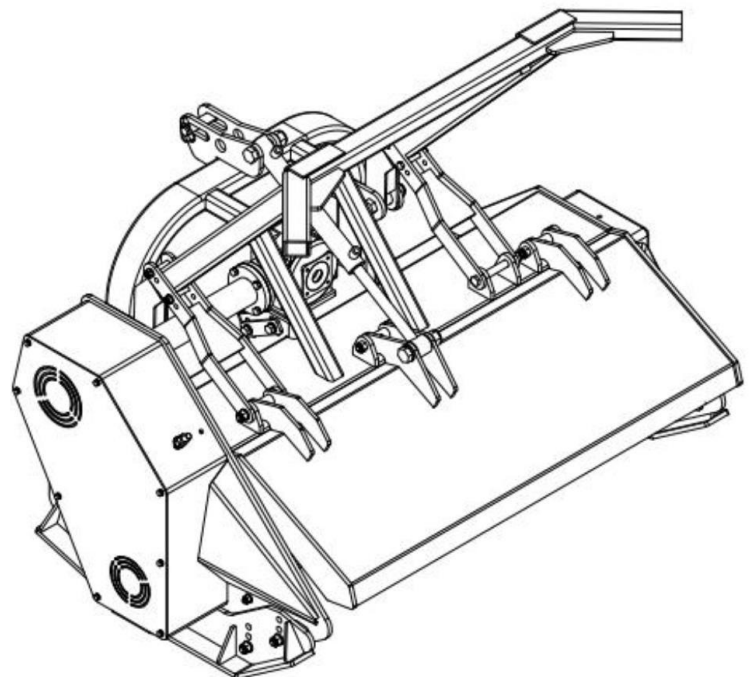
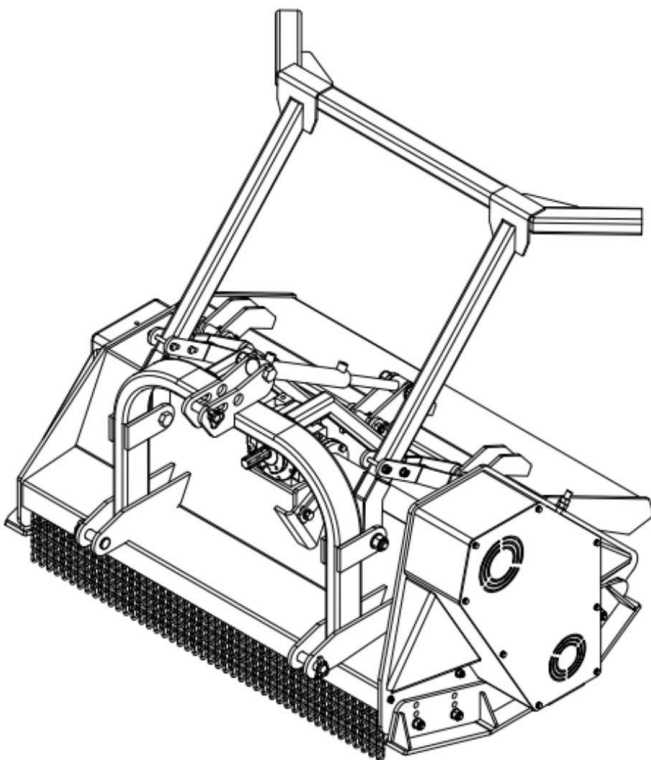

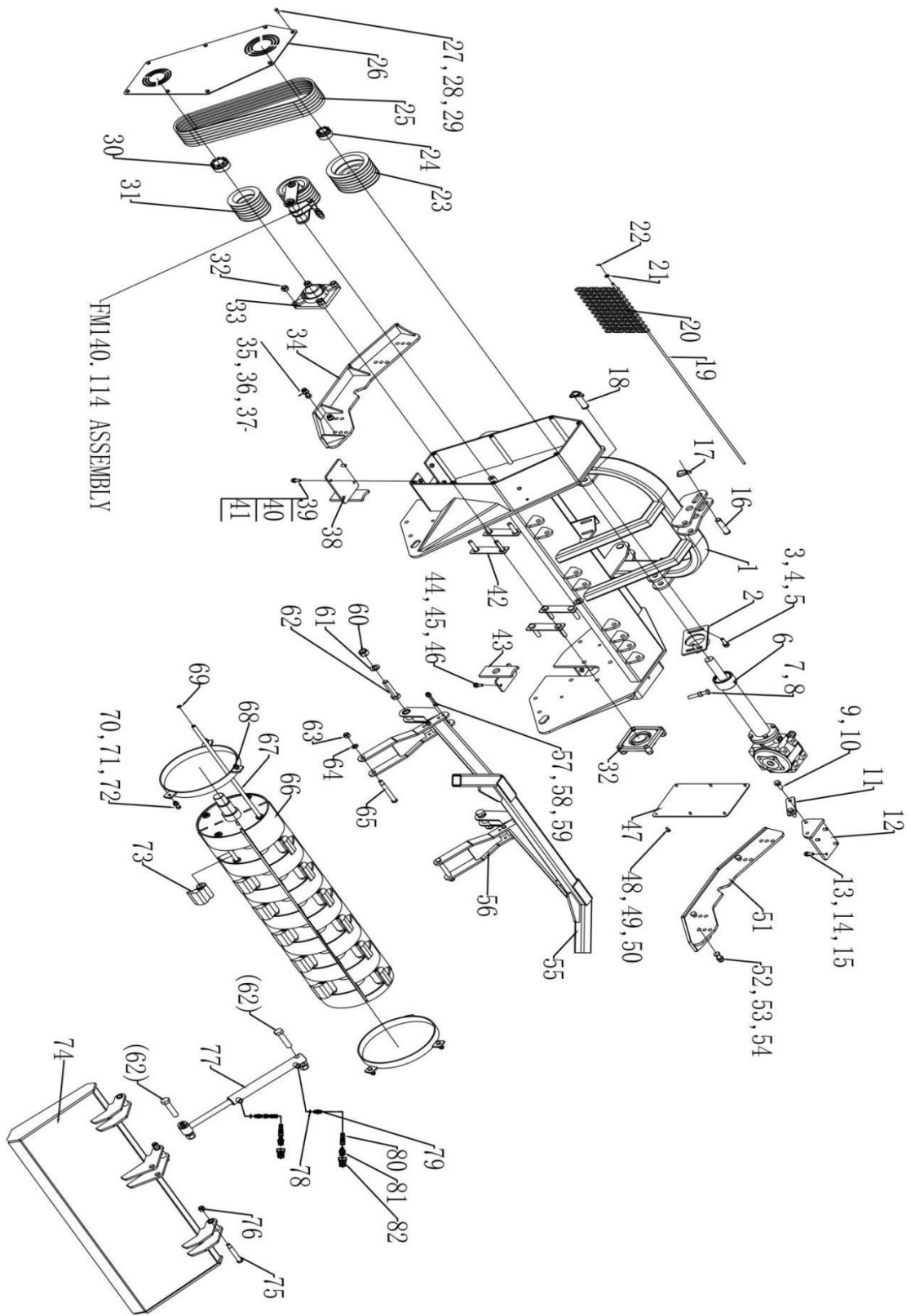



PART NO	PART SPEC	DESCRIPTION	QTY
1	FFM140.011	body well-meant	1
2	D220.018	adjust seat	1
3	GB97.1-14	washer 14	2
4	GB93-14	spring washer14	2
5	GB5783-M14x45	bolt M14X45	2
6	FFM140.004	gearbox assy	1
7	GB5783-M16x90	bolt M16X90	1
8	GB6170-M16	nut M16	1
9	GB5783-M14x50	bolt M14X50	2
10	GB93-14	spring washer14	2
11	FFM140.101	Plate	1
12	FFM140.012	gearbox seat	1
13	GB97.1-16	washer 16	4
14	GB93-16	spring washer16	4
15	GB5783-M16x1.5	Bolt	4
16	FFM140.102	top pin	1
17	LP 12	lock pin 12	3
18	FFM140.103	bottom pin	2
19	FFM140.104	Rod	1
20	FFM140.105	Chain	46
21	GB97.1-10	washer 10	2
22	GB91-3.2x16	split pin 3.2X16	2
23	FFM140.112	bigger pulley	1
24	REACH 04-4065	power lock 4065	1
25	REACH 04-4065	V-belt SPB1550	6
26	FFM140.106	left cover	1
27	GB97.1-8	washer 8	8
28	GB93-8	spring washer 8	8
29	GB5783-M8x20	bolt M8X20	8
30	REACH 04-5080	power lock 5080	1
31	FFM140.113	small pulley	1
32	GB889.1-M18	ock nut M18	8
33	UCF212	bear with seat	2
34	FFM140.013	left skid	1
35	GB889.1-M16	lock nut M16	4
36	GB97.1-16	washer 16	4
37	GB5783-M16x50	left plate	4
38	FFM140.014	left plate	1
39	GB97.1-12	washer 12	4
40	GB93-12	spring washer 12	4
41	GB5783-M12x35	bolt M12X35	4

PART NO	PART SPEC	DESCRIPTION	QTY
42	FFM140.016	bolt weldment	4
43	FFM140.015	right plate	1
44	GB97.1-12	washer 12	2
45	GB93-12	spring washer 12	2
46	GB5783-M12x35	bolt M12X35	2
47	FFM140.107	right cover	1
48	GB97.1-8	washer 8	6
49	GB93-8	spring washer 8	6
50	GB5783-M8x20	bolt M8X20	6
51	FFM140.017	right skid	1
52	GB5783-M16x50	bolt M16X50	4
53	GB97.1-16	washer 16	4
54	GB889.1-M16	lock nut M16	4
55	FFM140.018	saft frame	1
56	FFM140.019	saft frame support	2
57	GB5782-M12x90	bolt M12X90	4
58	GB97.1-12	washer 12	4
59	GB889.1-M12	lock nut M12	4
60	GB889.1-M24	lock nut M24	4
61	GB97.1-24	washer 24	4
62	GB5782-M24x11	bolt M24X110	4
63	GB889.1-M16	lock nut M16	2
64	GB97.1-16	washer 16	2
65	FFM140.108	long pin	2
66	FFM140.020	Roller	1
67	FFM140.109	knife pin	4
68	FFM140.021	Ring	2
69	GB893.1-19	internal circlip 19	8
70	GB889.1-M12	lock nut M12	6
71	GB97.1-12	washer 12	6
72	GB5783-M12x40	bolt M12X40	6
73	FFM140.110	Hammer	24
74	FFM140.022	rear plate	1
75	FFM140.111	short pin	2
76	GB889.1-M16	lock nut M16	2
77	FFM140.023	hydraulic cylinder	1
78	JB/ZQ4454-14	seal washer 14	2
79	BH5.60.109	Adapter 14-14	2
80	FFM140.024	hose assy	2
81	BV160.00.114	Adapter	2
82	QC-R1/2-M	Quickly dafter	2

## FM140.114 ASSEMBLY

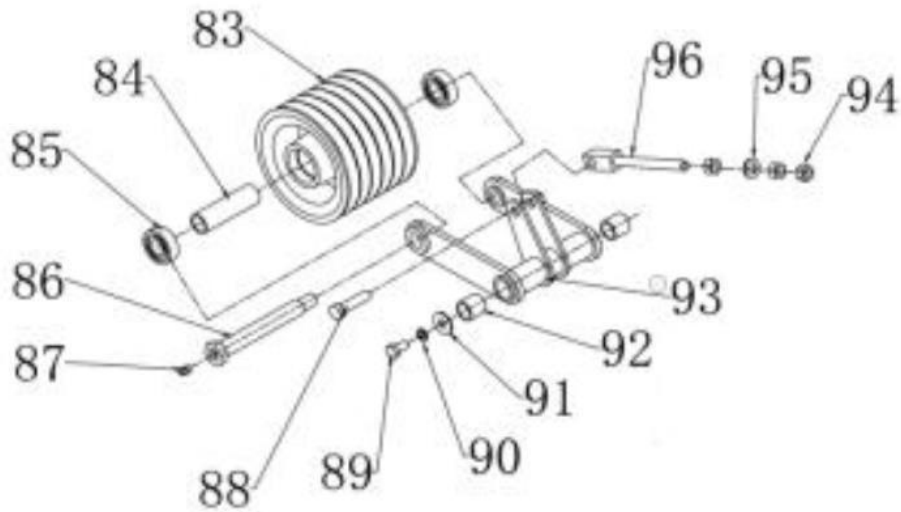

PART NO	PART SPEC	DESCRIPTION	QTY
83	FFM140.114	Tensioner	1
84	FFM140.115	bush	1
85	GB276-204	Bearing 204	2
86	FFM140.116	axle	1
87	GB1152-M8x1	Grease nipple	1
88	GB5672-M12x50	Bolt M12X55	1
89	GB5673-M10x20	bolt M10X20	1
90	GB93-10	Spring washer	1
91	GB5287-10	washer	1
92	FFM140.117	bush	2
93	FFM140.025	tensioned seat	1
94	GB6170-M12	nut	3
95	GB97.1-12	washer	1
96	FFM140.026	pul od	1

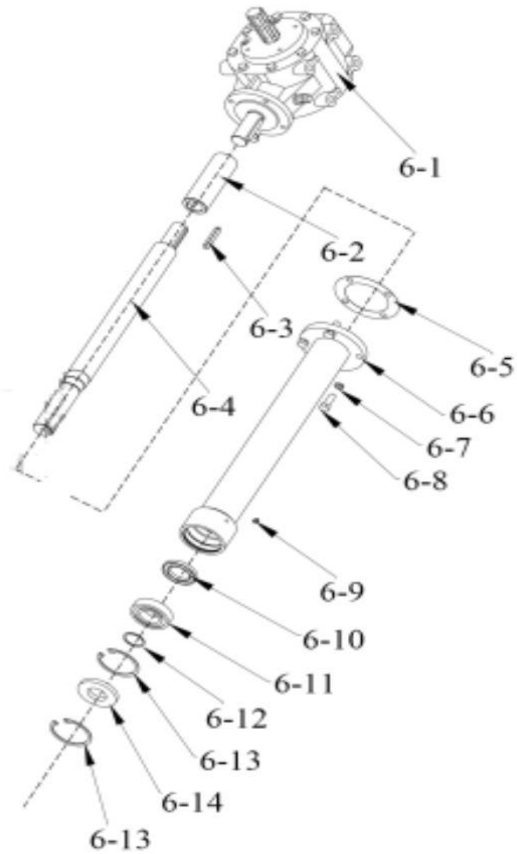

PART NO	PART SPEC	DESCRIPTION	QTY
6-1	XH650.001	gearbox XH650	1
6-2	FFM140.402	connector	1
6-3	GB1096-A10x65	key A10X65	1
6-4	FFM140.40	Axle	1
6-5	EFGC125.166	paper	1
6-6	FFM140.041	axle pipe	1
6-7	GB93-12	Spring washer12	4
6-8	GB5786-M12x1.2	bolt	4
6-9	GB1152-89	Grease nipple	1
6-10	GB13871	seal FB45X70X8	1
6-11	GB276-6208	Bearing 6208	1
6-12	GB894.1-40	external circlip	1
6-13	GB893.1-80	internal circlip	2
6-14	GB13871	seal	1