

30Ft x 80Ft Peak Ceiling Storage Shelter**Model: TMG-ST3080V-1.0**

- Please read the product manual completely before assembly
- Check against the parts list to make sure all parts are received
- Wear proper safety goggles or other protective gears while in assembly

Missing parts or questions on assembly?

Please call: 1-877-761-2819 or email: cs@tmgindustrial.com

Do not return the product to dealer, they are not equipped to handle your requests

Main Specifications :

- Overall assembled size : W9.15 x L24 x H4.57 (m) / 30 x 78.7 x 15(ft)
- Front and back roll up door : W3.65 x H3.3 (m) /12 x 10.8(ft)

Prior to assembly

Please read the instructions carefully before installation. It is important to follow your local safety regulations and industry standards during installation. Regulations may include but are not limited to :

- Safety helmets, protective eyewear, and clothing
- Safety harnesses for all elevated workers
- Proper ladder, cage, and safety operation

Check all components and parts before installation. All parts are marked with a part number, please refer to the parts list to make sure you have all parts.

Choose a day with low or no wind to install, assembly is hard in heavy wind. Do not make any alterations to the structure. Do not hang any weights on the frame during installation, including parts. We are not responsible for any damages or injuries caused by inappropriate installation, unauthorized modifications or extreme weather.

This building is not intended for human occupancy.

It is recommended to tape or add foam/rubber on the frame where joints connect and where it touches the cover. This will help extend the life span of the cover.

Read the following item list carefully and count the number of items to ensure that all parts are included prior to setup.

Installation steps











Step 1 : Review the whole structure and choose the proper installation site



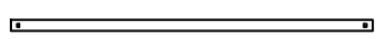



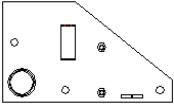
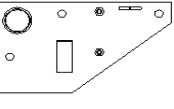
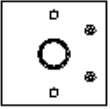
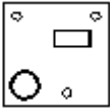

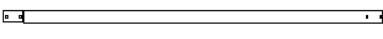

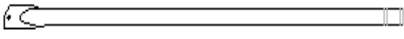
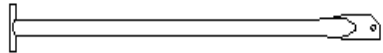
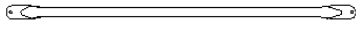
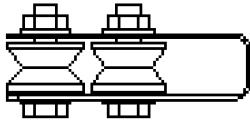
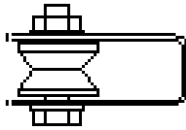
Choose a solid flat level ground area to set up the building. Do not install the building on soft ground, wetland, uneven surfaces, sloped surfaces, or on top of structures that are not rated to hold its weight.

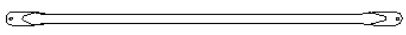

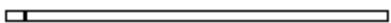

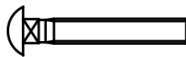
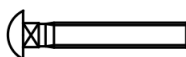

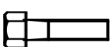
We strongly recommend that you build the structure on a solid foundation such as cement and use anchor bolts on all baseplates.

Be aware of the surrounding area. Do not set up the building near snowdrifts, open flames or exposed electrical wires. Do not keep heat sources near the fabric cover. Keep the building surroundings clear at all times.

TMG-ST3080V-1.0 Part List

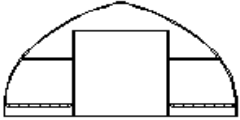
Parts code	Graphical	Description	Length	Qty
1		Peak arch tube	φ 58xL2290mm	17
2		Upper rafter tube (middle truss)	φ 58xL2866mm	30
2A		Upper rafter tube (front and rear truss)	φ 58xL2866mm	4
3		Lower rafter tube (middle truss)	φ 58xL2800mm	30
3A		Lower rafter tube (front and rear truss)	φ 58xL2800mm	4
4		Roof purlin (horizontal tube)	φ 42xL1440mm	80
4A		Middle truss connectors	W50xL180mm	150
4B		Front and rear connectors	W50xL121mm	10
4C		Self-tapping screws (#12x25mm)	#12x25mm	85
5L		Left corner baseplate (front and rear truss)	W200xL350mm	2
5R		Right corner baseplate (front and rear truss)	W200xL350mm	2
6		Door column baseplate (front and rear truss)	W150xL200mm	4
7		Middle truss baseplate	W200xL200mm	30
7A		Ratchets	3T	34
8		Door frame lower tube (front and rear truss)	φ 58xL1920mm	4

9		Door frame upper tube (front and rear truss)	φ 58xL1800mm	4
10		Door frame middle tube (front and rear truss)	φ 42xL2090mm	4
11		Ceiling cross bar	φ 42xL2480mm	17
11A		Rope pulley	W35xL130mm	2
11B		Rope pulley	W35xL85mm	2
12		Bottom tension bar (front and rear cover)	φ 32xL2560mm	4
13		Diagonal bracing bar (for 1st and last span)	φ 42xL2070mm	4
13A		Tube clamp	φ 58mm	8
14		Top cover tension tube (for both bottom sides)	φ 32xL1993mm	2 groups
15		Door dropping tube	φ 32xL1993mm	2 groups
16		Expansion bolt (not included)	φ 16x150mm	110
17		Half round head bolt	M8x60mm	160
18		Half round head bolt	M8x70mm	220
19		Hex bolt	M10x30mm	42
19A		Hex bolt	M10x50mm	8
20		Nylon rope	φ 8x12m	4

21		Water plug	φ 32mm	16
22		Top cover		1
23		Front and rear cover panel		2
24		Braided rope	φ 8x160m	1 bundle
25		Tension band	W38xL800mm	34
26		Scratch resistant tape	L10m	3

- Mark the ground in the final building location with a line showing the positions of base plates, front, and rear doors. All lines should be drawn from center to center of all baseplate tubes.
- Baseplates : all baseplates must be installed firmly with expansion bolts (#16) on this step (figure 1).
- Parts used in this step :
 - (4) Baseplates (#5L,#5R)
 - (30) Baseplates (#7)
 - (4) Baseplates (#6)
 - (110) Expansion bolts (#16)

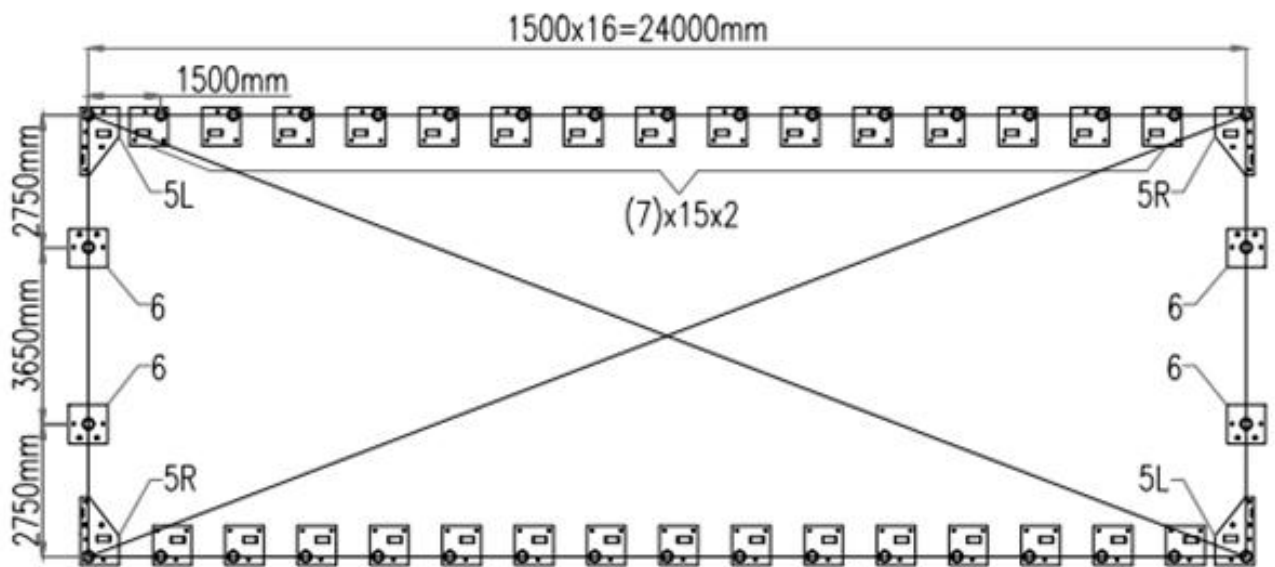

Figure 1

Step 2 : Assemble all trusses

- The building includes 17 trusses : (1) Front truss (1st truss), (1) rear truss (17th truss), and (15) middle trusses. The front and rear trusses are installed with the fabric panel (#23).
- Both front and rear truss include the following parts. Connect all tubes with bolt (#18)(refer to figure 2).
 - (1x2) Peak arch tube (#1)
 - (2x2) Upper rafter tube (#2A)
 - (2x2) Lower rafter tube (#3A)
 - (1x2) Ceiling cross bar (#11)
 - (2x2) Hex bolt (#19)
 - (8x2) Half round head bolt (#18)

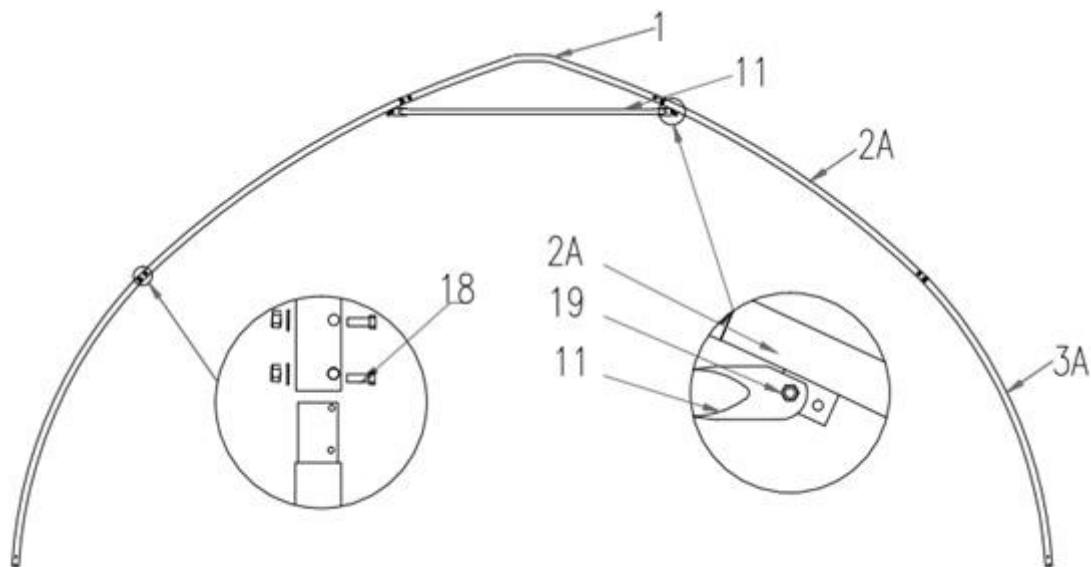

Figure 2

- The (15) middle trusses include the following parts. Connect all tubes with bolt (#18) (refer to figure 3).
 - (1x15) Peak arch tube (#1)
 - (2x15) Upper rafter tube (#2)
 - (2x15) Lower rafter tube (#3)
 - (1x15) Ceiling cross bar (#11)
 - (2x15) Hex bolt (#19)
 - (8x15) Half round head bolt (#18)

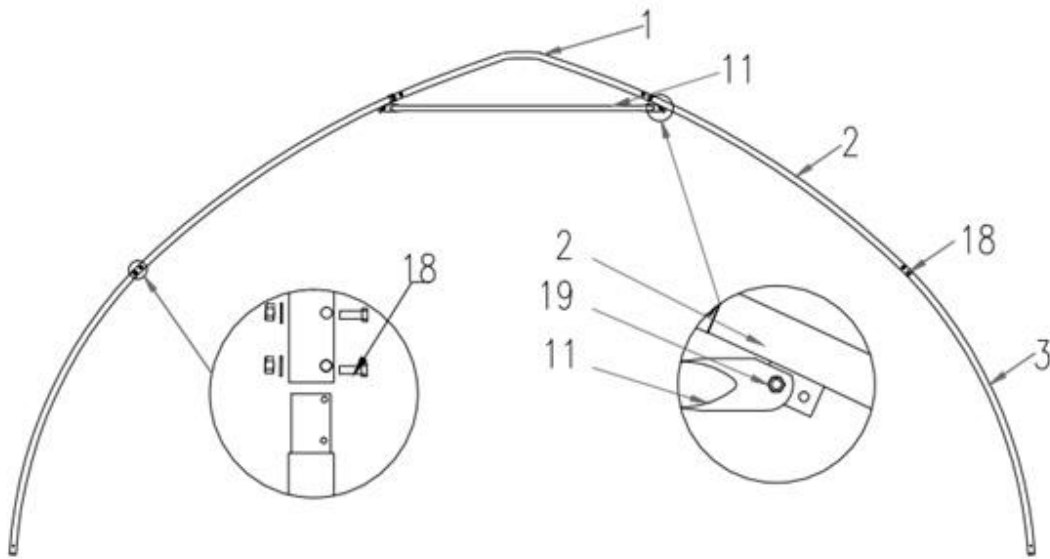

Figure 3

- Lay down all (17) trusses on the ground as Figure 4 when the assembly is all completed and before moving to next step, and then wrap (#26) around the sharp points of the joint to avoid friction between the fabric and the interface, resulting in fabric damage (figure 4).

- (3) Scratch resistant tape (#26)

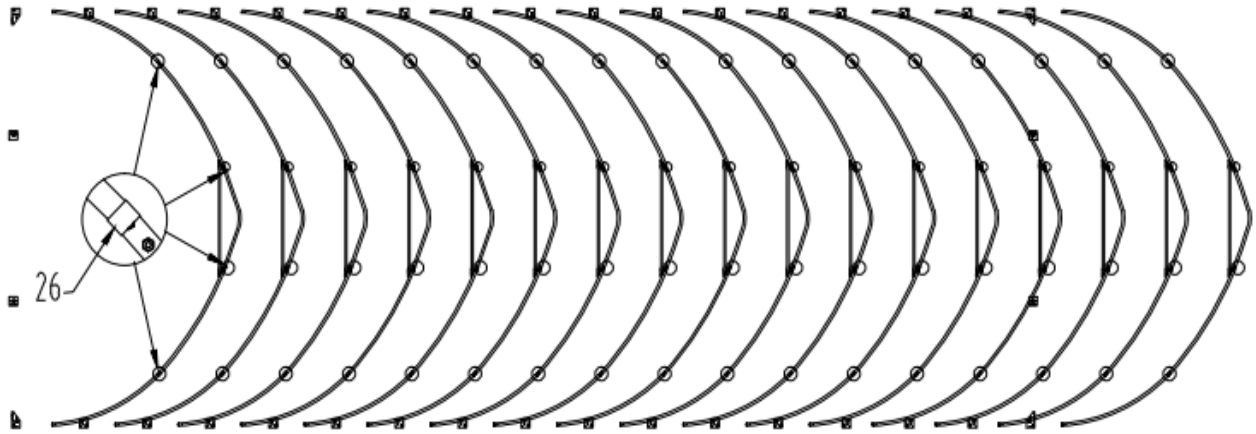

Figure 4

Step 3 : Put up the front (1st) truss

- Use of a crane or forklift is recommended, otherwise a team can use ropes to lift the trusses, but you have to make sure it is safe, and have enough manpower. We recommend 3 to 5 people to pull the truss up from different directions. When the truss is up, tie the ropes to the heavy objects to make sure the truss will stay upright and use bolt (#18) to connect the truss to the baseplate on both sides (figure 5).
- Parts used on this step : (4) Half round head bolt (#18)

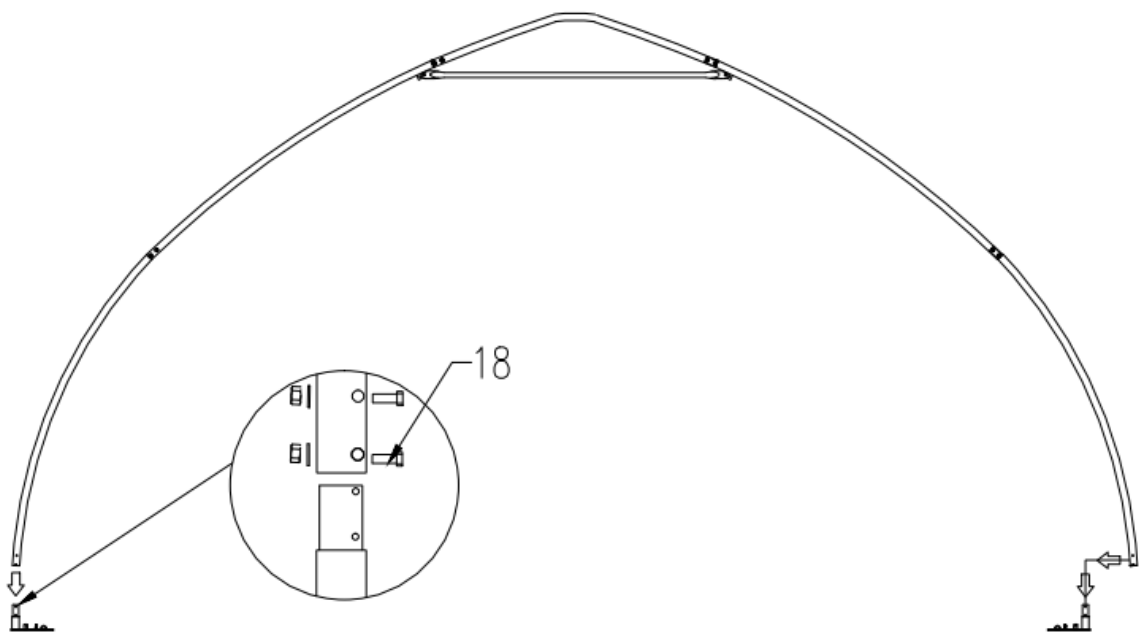

Figure 5

Step 4 : Put up the rest trusses

- Refer to Step 3 to put up the rest trusses, connect all 5 purlins (#4) with bolt (#17) and secure all bolts firmly on each span before going to next truss (figure 6).
- Parts used in this step :
 - (80) Roof purlin (#4)
 - (150) Middle truss connectors (#4A)
 - (10) Front and rear connectors (#4B)
 - (85) Self-tapping screws (#4C)
 - (160) Half round head bolt (#17)

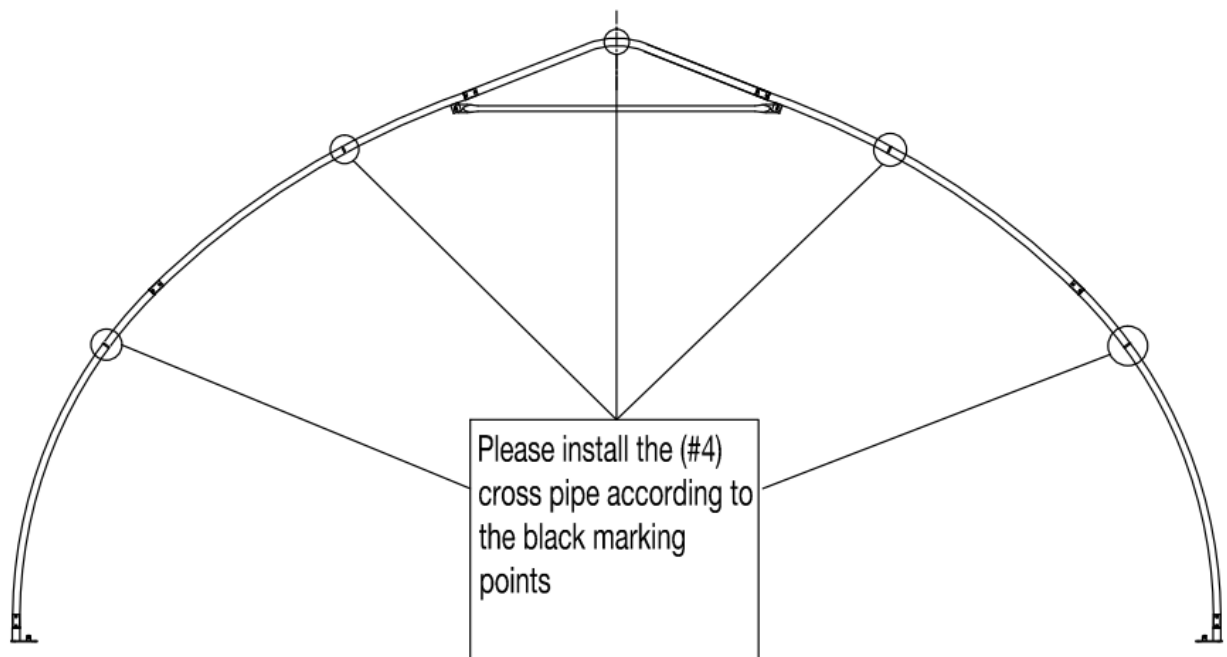

Figure 6-1

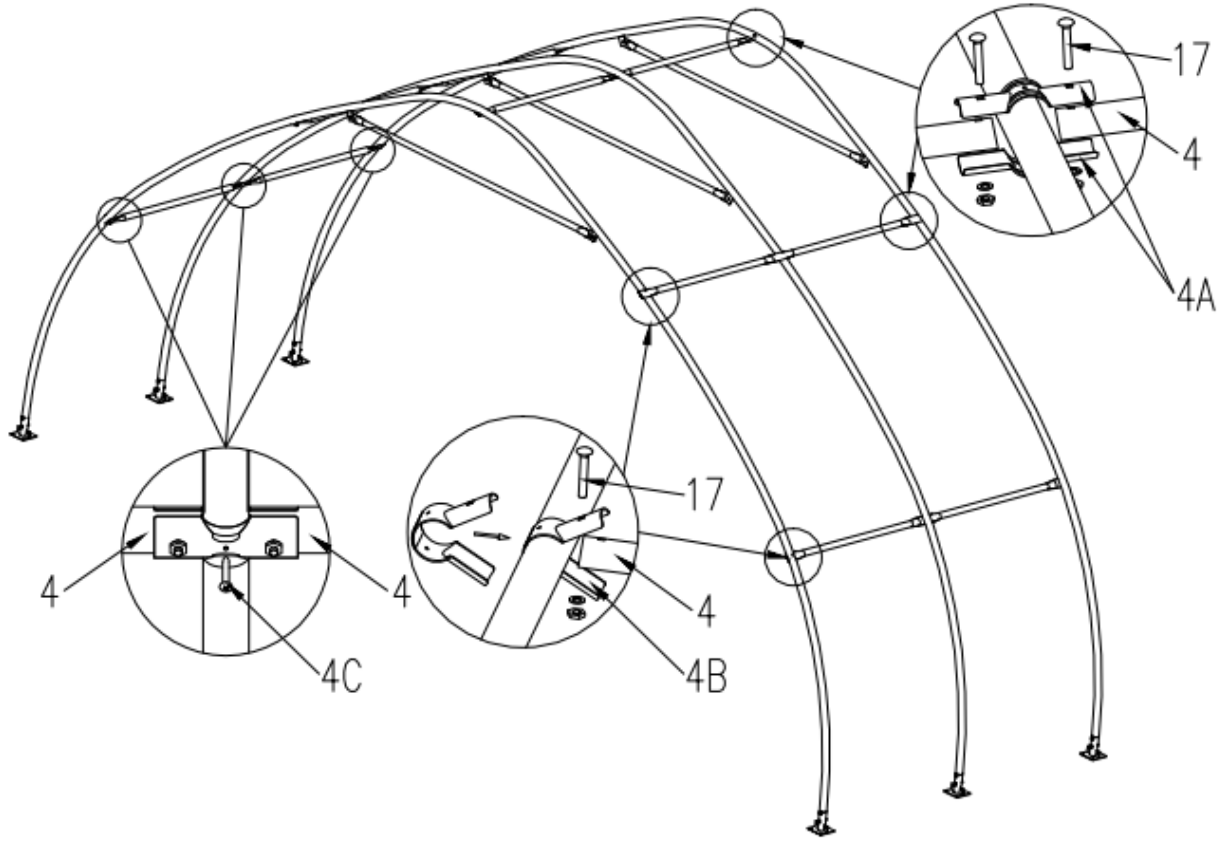

Figure 6-2

Step 5 : Install the diagonal bracing bars (#13)

- Connect diagonal bracing bar (#13) on the first and last span to lower rafter tube (3A and 3) with tube clamp (#13A), use bolt (#19A) (figure 7).
- Parts used in this step :
 - (2x2) Diagonal bracing bars (#13)
 - (4x2) Tube clamps (#13A)
 - (4x2) Bolts (#19A)

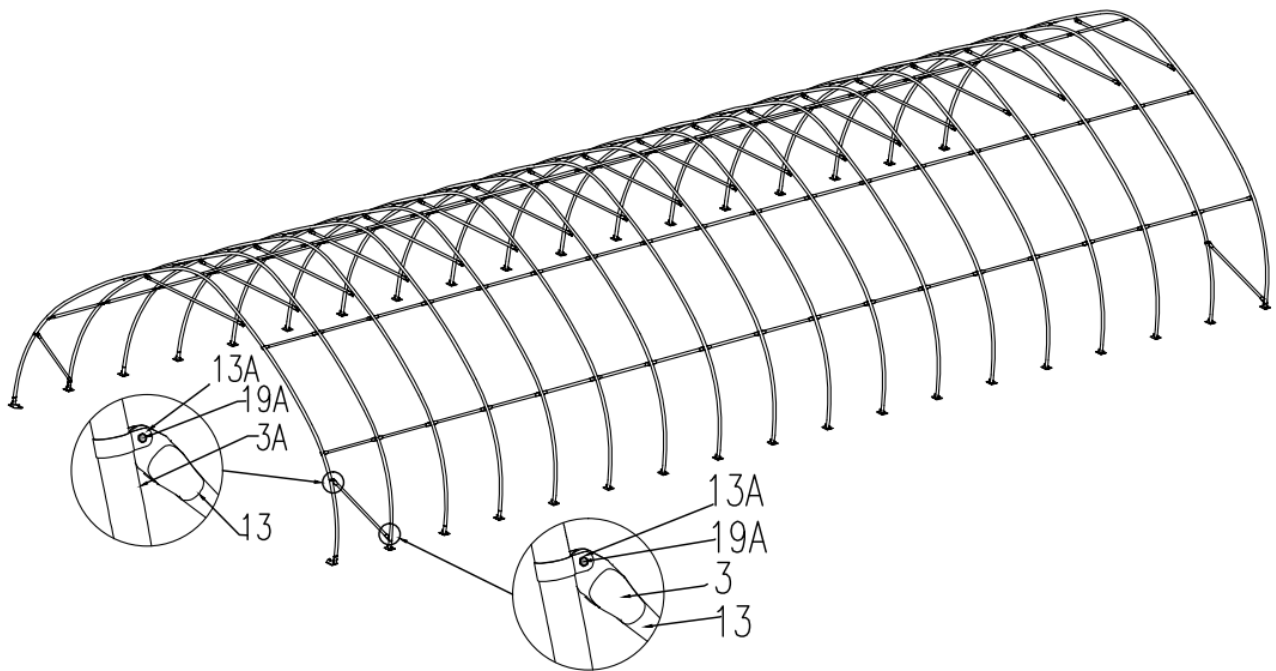

Figure 7

Step 6 : Install the remaining parts on the front and rear trusses (figure 8)

- Install rope pulley (#11A) on the right, (#11B) on the left as shown.
- Parts used in this step :
 - (2x2) Door frame lower tube (#8)
 - (2x2) Door frame upper tube (#9)
 - (2x2) Door frame middle tube (#10)
 - (1x2) Rope pulley (#11A)
 - (1x2) Rope pulley (#11B)
 - (2x2) Bottom tension bar (#12)
 - (8x2) Half round head bolt (#18)
 - (4x2) Hex bolt (#19)

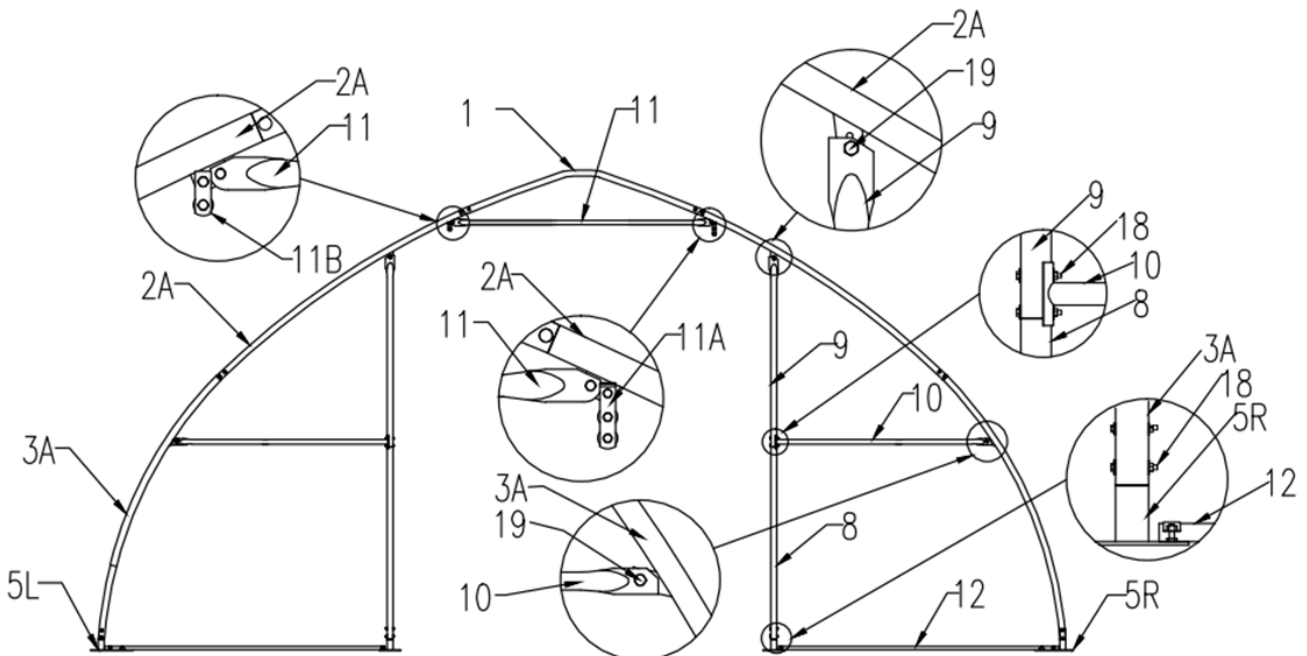
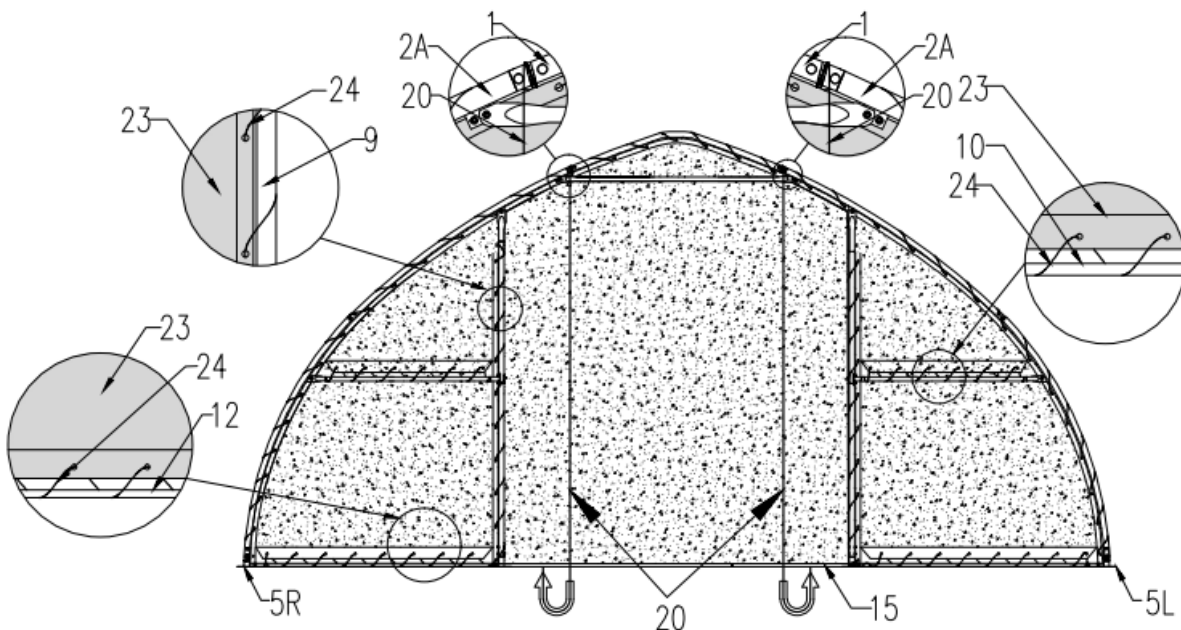

Figure 8

Step 7 : Install front and rear cover panel

- The door cover must be zipped. Use rope (#24) to lift up the front cover (#23) from the center grommet and tie it firm to the truss tube and spread toward both sides through each grommet along the tube. Refer to Figure 9 and 10 on how to attach the rope and tie to the tube.
- Insert the dropping tube (#15) into the bottom groove pocket on the door cover. Tie two ropes (#20) separately on both sides of the peak arch tube. Pull both ropes under through the bottom of the door cover from the back, then go up from front and through both pulley (#11A) and (#11B) (figure 9).
- Parts used in this step :
 - (1x2) Door dropping tube (#15)
 - (2x2) Nylon rope (#20)
 - (1x2) Front and rear cover panel (#23)
 - (1) Braided rope (#24)



(Figure 9 - view from inside)

- The rope coming out from pulley (#11B) must go through the upper wheel of pulley (#11A), then pull both ropes together slowly and start to lift the door cover.
- Tie both ropes to the corner baseplate. Now the door cover is up. When you drop down the door cover, do not let go too quick, otherwise it might get stuck and damage the fabric (figure 10).

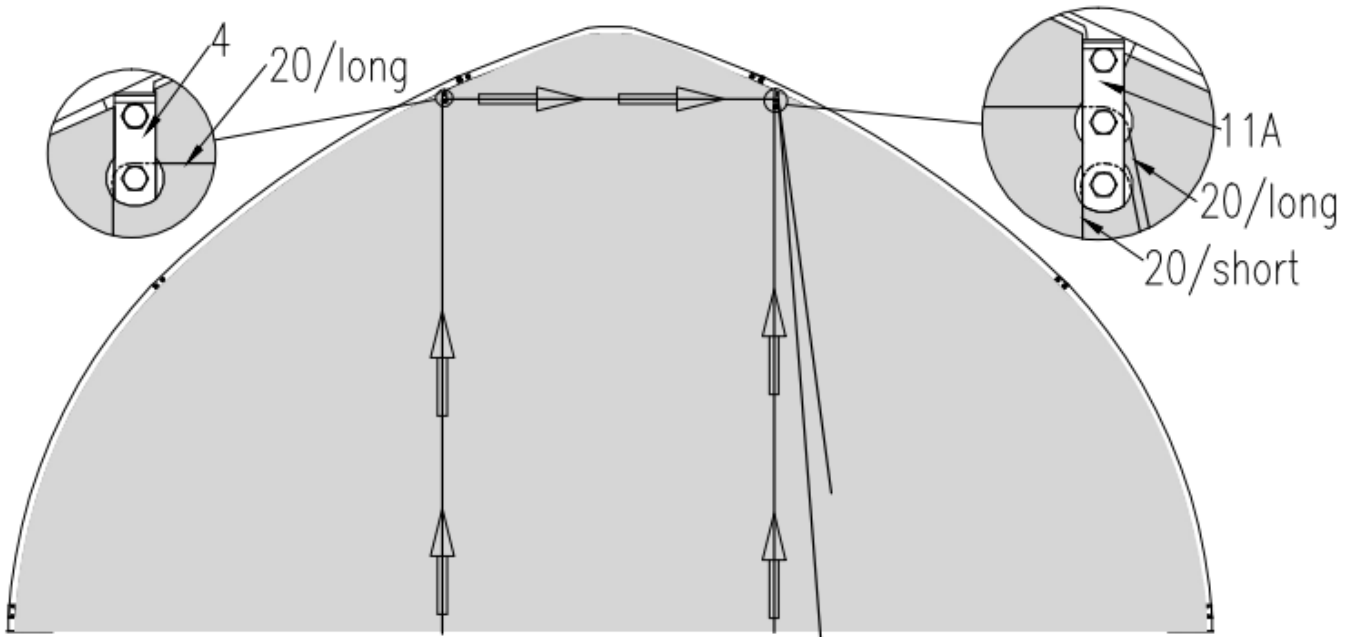

(Figure 10 -view from outside)

Step 8 : Install the top cover (#22)

Do not install the cover during windy weather!

- Unpack the top cover and place it along one of the long sides of the structure.
- Use 3 to 5 ropes (#24) to pull the top cover (#22) the top of the structure, 2 or 3 people standing inside on ladders to push upwards will help to move the cover smooth without any damage (figure 11).

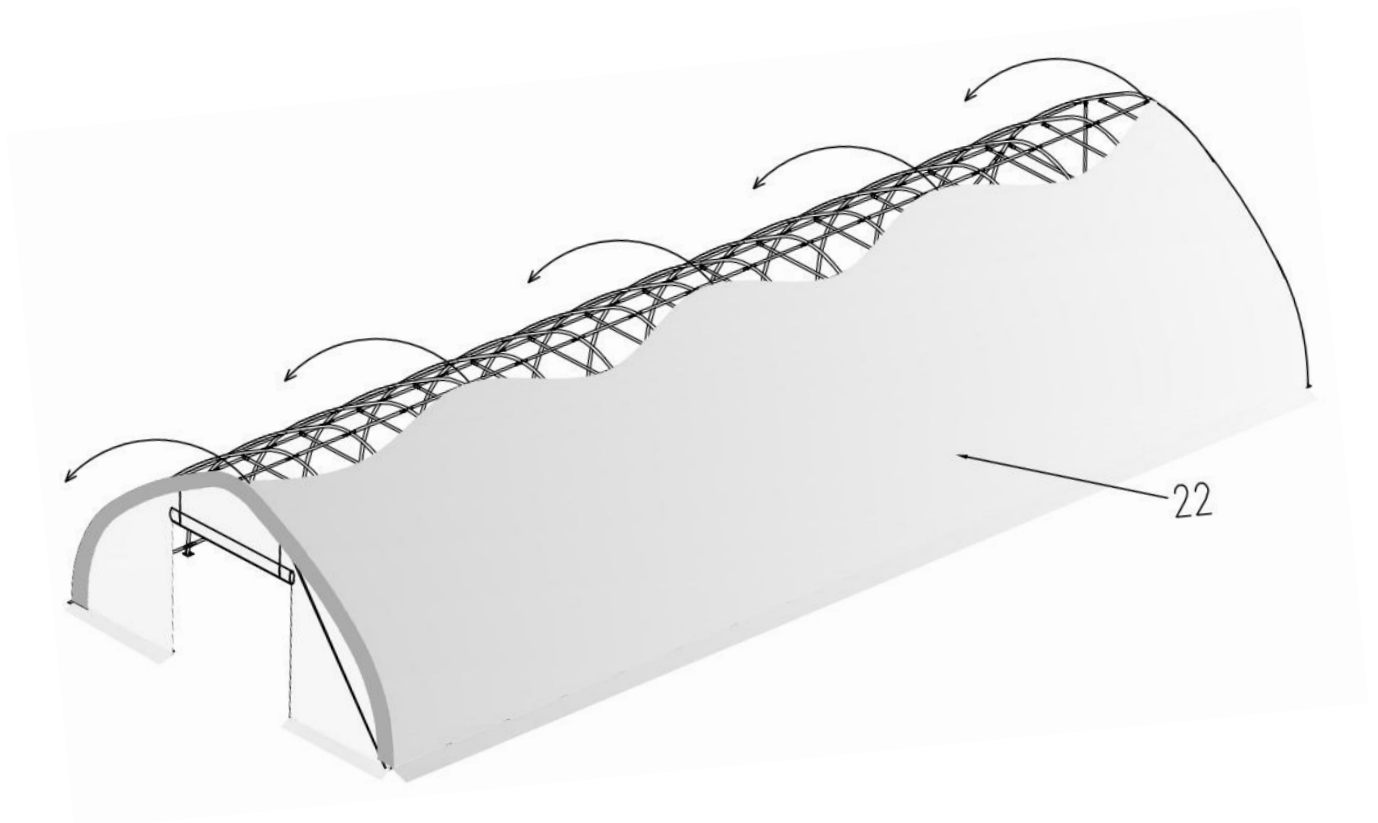

Figure 11

Step 9 : Stretch and tighten top cover

- The roof cover must be stretched and tied to the front and rear truss by rope going through the flap grommets on the cover. Start from the top center and go toward both side on each end. Add or cut the rope as needed.
- Pull and stretch the cover enough only to take wrinkles out. Repeat for the rear truss. Do not over stretch as it could rip off the grommets (figure 12).

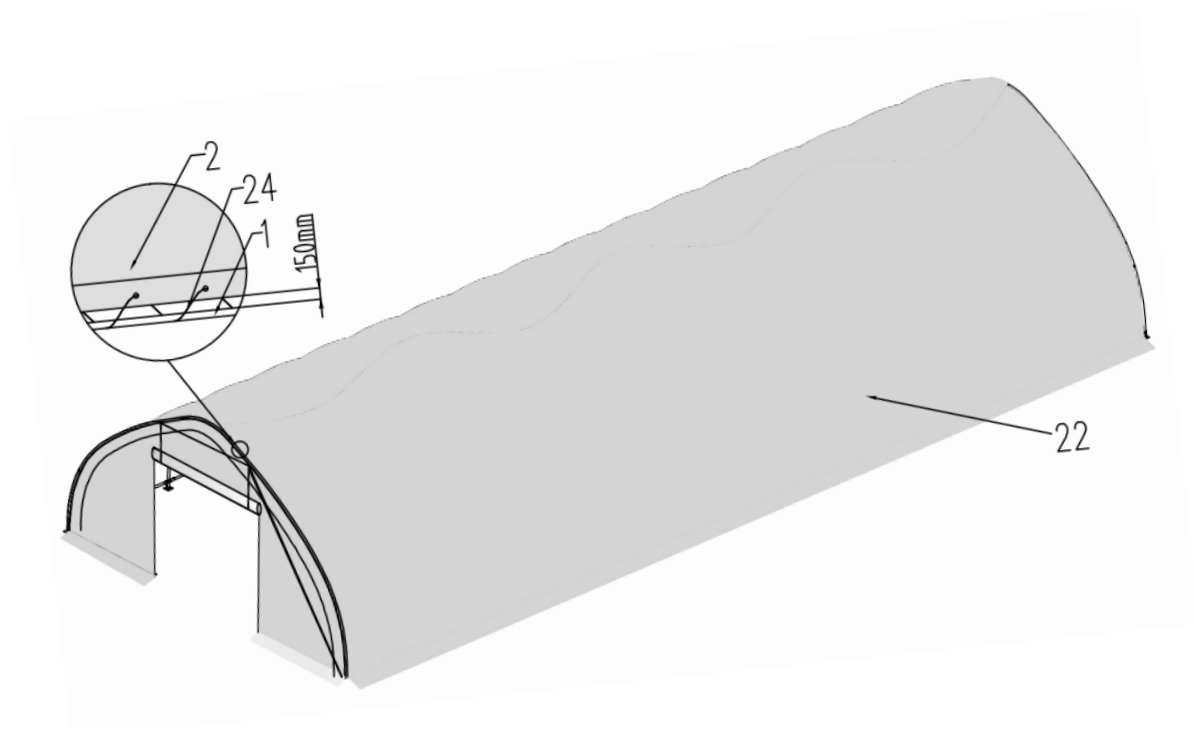

Figure 12

Step 10 : Tension the cover on the structure from both sides (figure 13)

- Insert tension tubes (#14) slowly into the bottom groove pocket on both long sides. Add the water plug (#21) on the first tension tube to avoid tearing the fabric and add one to the end of last tube as well.
- Repeat the same step for the other side.

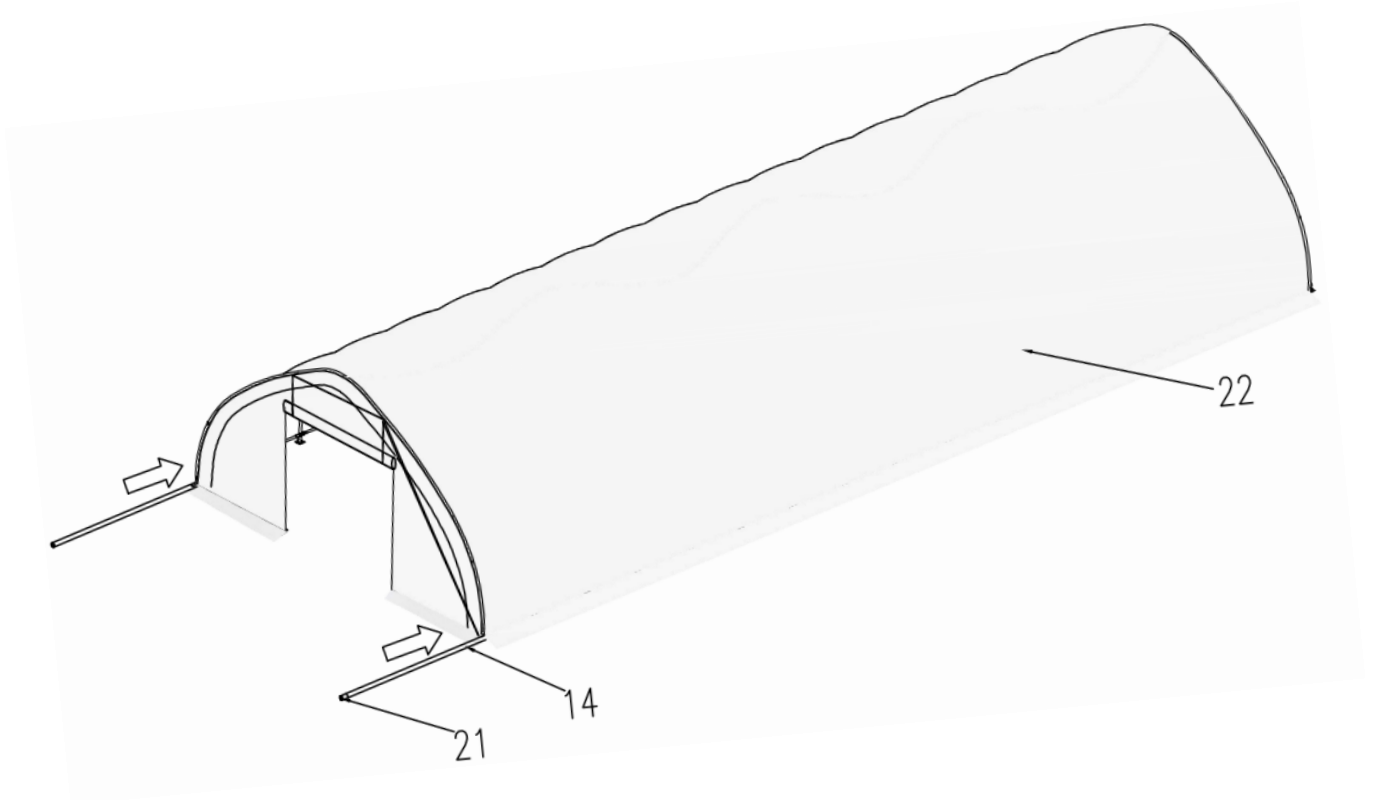

Figure 13

Step 11 : Install ratchet straps (#25)

- Stretch and adjust the cover from left and right, back and forth, to make sure it is square and centered. Cut the groove pocket where it aligns with ratchet (#7A), and use tension band (#25) to pull tension tube (#14) to ward the ratchet and secure it.
- Evenly adjust all ratchets on both sides to take wrinkles out and make the cover flat and smooth.
- Parts used in this step :
 - (34) Ratchets (#7A)
 - (34) Tension band (#25)

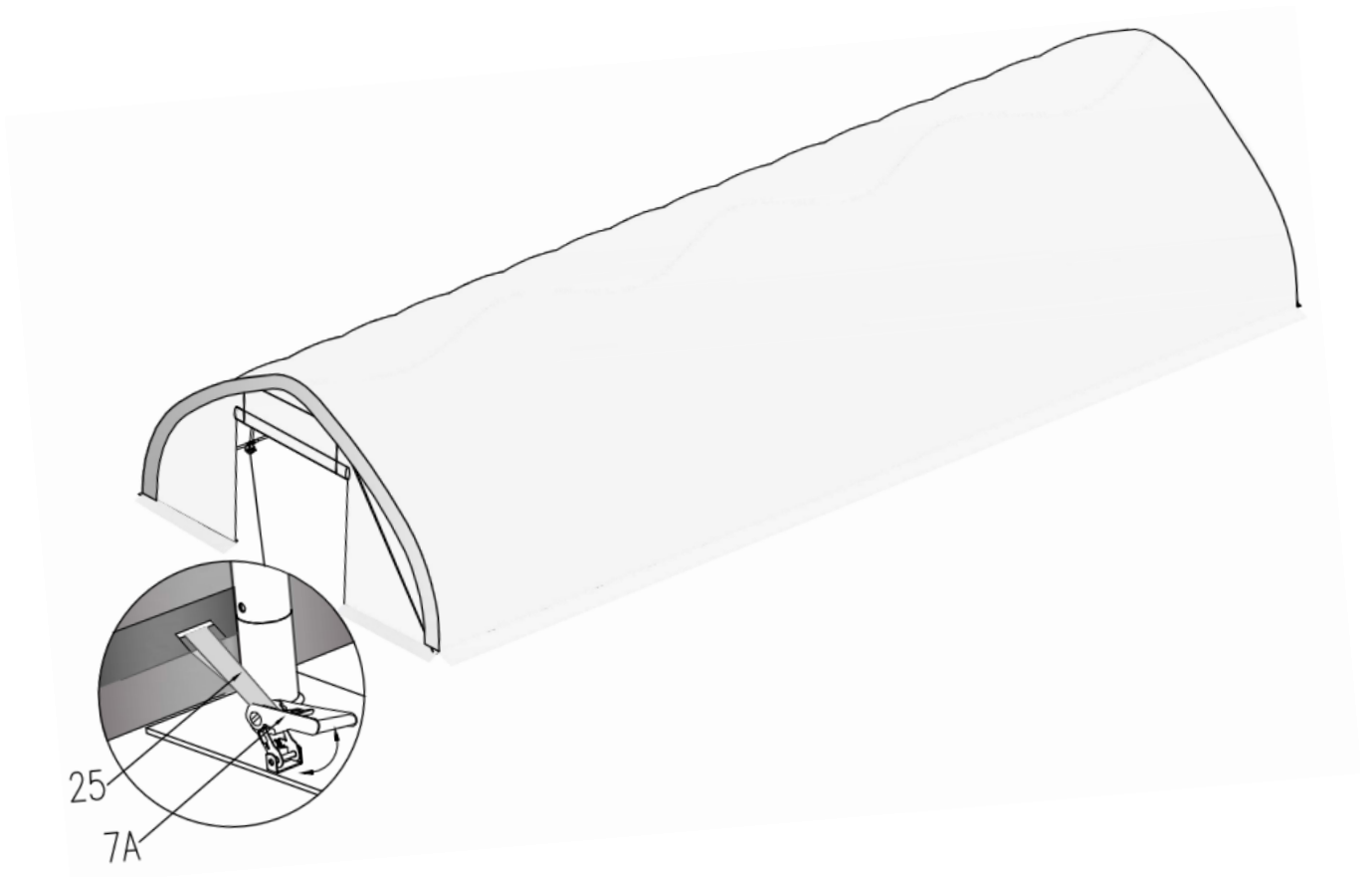

Figure 14

After the Installation

Walk around and inspect the shelter periodically to make sure all components are still firmly secured and the whole shelter is well supported. Check all bolts and nuts as well as all connection points to make sure they are all in good position. Check the base plates, adjust the ropes and tie downs if required and clean the cover regularly.

Snow accumulating on the fabric cover must be removed as soon as possible. If snow becomes solid ice on the cover, it will increase the weight on the roof and may collapse the shelter or reduce the life span.

Keep the shelter on a dry ground most of the time. Do not keep the fabric dirt skirt under water all the time, otherwise the fabric will deteriorate.

We strongly recommend you remove any snow from the roof immediately. Do not leave any snow load on the roof overnight. Keep 3 feet of clearance on all sides at all times. Do not allow snow to accumulate and pile up on the sides of the building. Otherwise the pressure from the sides will push inwards and could lead to a collapse.