

30Ft x 50Ft Straight Wall Storage Shelter**Model: TMG-ST3050-2.0**

- Please read the product manual completely before assembly
- Check against the parts list to make sure all parts are received
- Wear proper safety goggles or other protective gears while in assembly

Missing parts or questions on assembly?

Please call: 1-877-761-2819 or email: cs@tmgindustrial.com

Do not return the product to dealer, they are not equipped to handle your requests

Main Specifications :

- Assembly size : W9.14 x L15 x H4.8 (m) / 30 x 50 x 16 (ft)
- Shoulder height : 2 m / 6.6 ft
- Front and back roll up door : 4 x 3.89 (m) / 13.1 x 12.7 (ft)

Prior to assembly

Please read the instructions carefully before installation. It is important to follow your local safety regulations and industry standards during installation. Regulations may include but are not limited to :

- Safety helmets, protective eyewear, and clothing
- Safety harnesses for all elevated workers
- Proper ladder, cage, and safety operation

Check all components and parts before installation. All parts are marked with a part number, please refer to the parts list to make sure you have all parts.

Choose a day with low or no wind to install, assembly is hard in heavy wind. Do not make any alterations to the structure. Do not hang any weights on the frame during installation, including parts. We are not responsible for any damages or injuries caused by inappropriate installation, unauthorized modifications or extreme weather.

This building is not intended for human occupancy.

It is recommended to tape or add foam/rubber on the frame where joints connect and where it touches the cover. This will help extend the life span of the cover.

Read the following item list carefully and count the number of items to ensure that all parts are included prior to setup.

Installation steps







Step 1 : Review the whole structure and choose the proper installation site



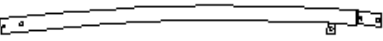

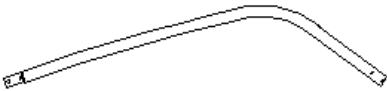
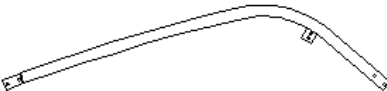
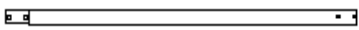



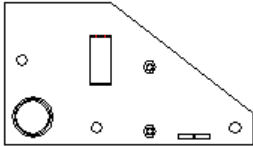
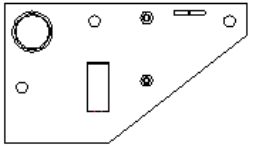
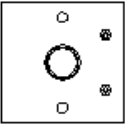

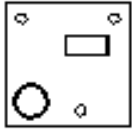
Choose a solid flat level ground area to set up the building. Do not install the building on soft ground, wetland, uneven surfaces, sloped surfaces, or on top of structures that are not rated to hold its weight.

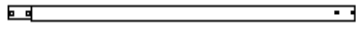

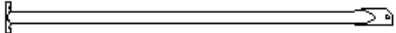
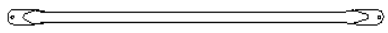
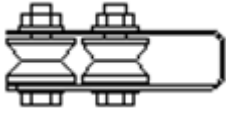

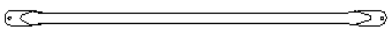

We strongly recommend that you build the structure on a solid foundation such as cement and use anchor bolts on all baseplates.

Be aware of the surrounding area. Do not set up the building near snowdrifts, open flames or exposed electrical wires. Do not keep heat sources near the fabric cover. Keep the building surroundings clear at all times.

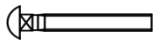
TMG-ST3050-2.0 Part List

Parts code	Graphical	Description	Length	Qty
1		Peak arch tube	φ 58xL1712mm	11
2		Upper rafter tube (middle truss)	φ 58xL2870mm	18
2A		Upper rafter tube (front and rear truss)	φ 58xL2870mm	4
3		Shoulder tube (middle truss)	φ 58xL1757mm	18
3A		Shoulder tube (front and rear truss)	φ 58xL1757mm	4
4		Sidewall tube	φ 58xL1465mm	22
5		Roof purlin (horizontal tube)	φ 42xL1440mm	90
5A		Middle truss connectors	W50xL180mm	162
5B		Front and rear connectors	W50xL180mm	18
5C		Self-tapping screws	W62xL121mm	99
5L		Left corner baseplate (front and rear truss)	W200xL350mm	2
5R		Right corner baseplate (front and rear truss)	W200xL350mm	2
6		Door column baseplate (front and rear truss)	W150xL200mm	4

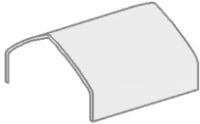
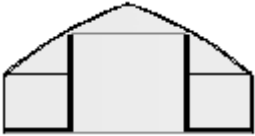
7		Middle truss baseplate	W200xL200mm	18
7A		Ratchet	3T	22
8		Door frame lower tube (front and rear truss)	φ 58xL1970mm	4
9		Door frame upper tube (front and rear truss))	φ 58xL1982mm	4
10		Door frame horizontal tube (front and rear truss)	φ 42xL2507mm	4
11		Ceiling cross bar	φ 42xL2810mm	11
11A		Two wheel rope pulley (pre-installed on 2A)	W35xL130mm	2
11B		One wheel rope pulley (pre-installed on 2A)	W35xL85mm	2
12		Bottom tension bar (front and rear cover)	φ 32xL2400mm	4
13		Diagonal bracing bar (1st and last span)	φ 42xL1930mm	4
13A		Tube clamp	φ 58mm	8
14		Top cover tension tube (for both bottom sides)	φ 32xL1993mm	2 groups
15		Door dropping tube	φ 32xL1993mm	2 groups
16		Expansion bolt (not included)	φ 16x150mm	74

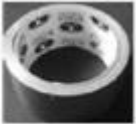
17		Half round head bolt	M8x60mm	180
18		Half round head bolt M8x70mm	M8x70mm	192
19		Hex bolt	M10x30mm	30
19A		Hex bolt	M10x50mm	8
20		Nylon rope	φ 8x15m	4
21		Water plug	φ 32mm	16
22		Top cover		1
23		Front and rear cover panel		2
24		Braided rope	φ 8x180m	1
25		Tie down straps (for #7A and front and rear arches)	W38xL800mm	30
26		Scratch resistant tape	L10m	4

Mark the ground in the final building location with a line showing the positions of base plates, front, and rear doors. All lines should be drawn from center to center of all baseplate tubes. Diagonal line X must be equal to Y.

- Baseplates : all baseplates must be installed firmly with expansion bolts (#16) on this step (picture 1).
- Parts used in this step :
 - (4) Baseplates (#5L, #5R)
 - (18) Baseplates (#7)
 - (4) Baseplates (#6)
 - (74) Expansion bolts (#16)

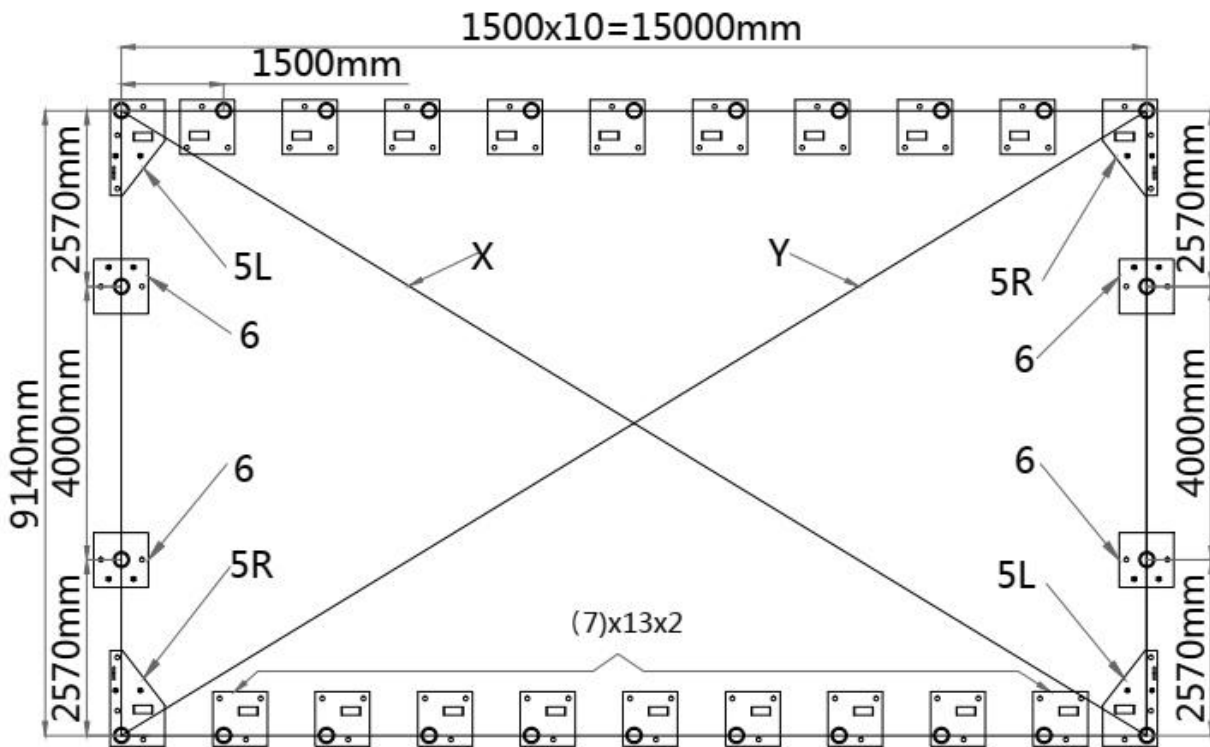

Picture 1

Step 2 : Assemble all trusses

The building includes 11 trusses : (1) front truss, (1) rear truss, and (9) middle trusses. The front and the rear truss are to install with the fabric panel (#23).

- Parts used to install the front and rear truss in this step (refer to picture 2):
 - (1x2) Peak arch tube (#1)
 - (2x2) Upper rafter tube (#2A)
 - (2x2) Shoulder tube (#3A)
 - (2x2) Sidewall tube (#4)
 - (1x2) Ceiling cross bar (#11)
 - (2x2) Hex bolt (#19)
 - (12x2) Half round head bolt (#18)

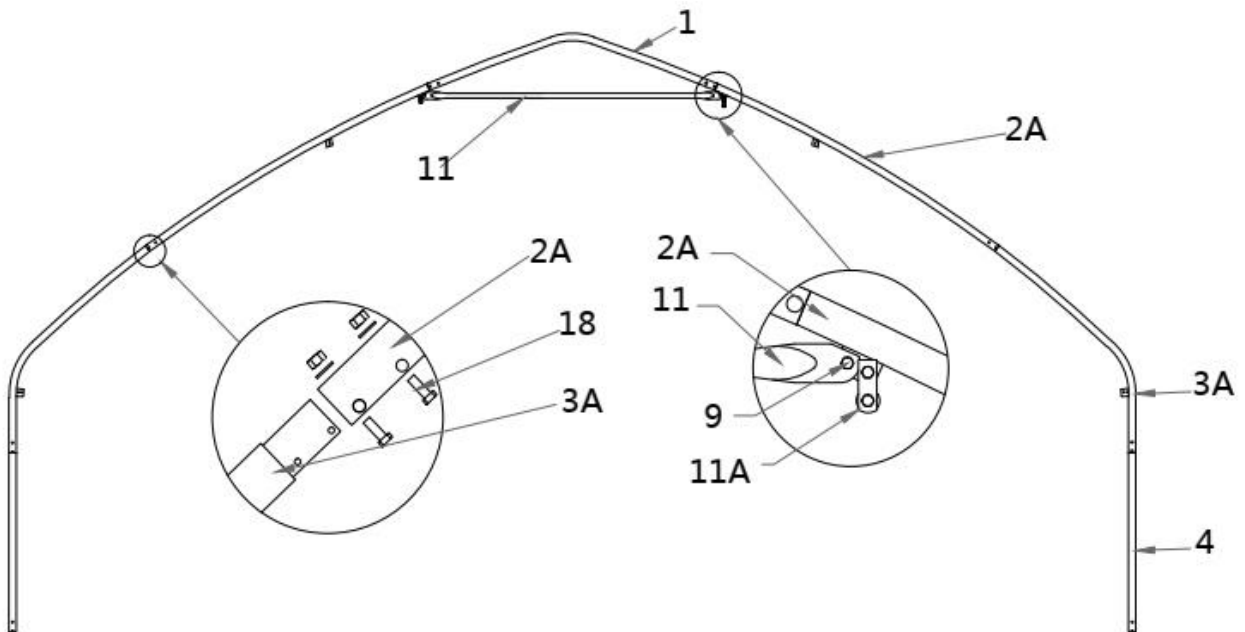

Picture 2

- Parts used to install (9) middle trusses in this step (refer to picture 3).

- (1x9) Peak arch tube (#1)
- (2x9) Upper rafter tube (#2)
- (2x9) Shoulder tube (#3)
- (2x9) Sidewall tube (#4)
- (1x9) Ceiling cross bar (#11)
- (2x9) Hex bolt (#19)
- (12x9) Half round head bolt (#18)

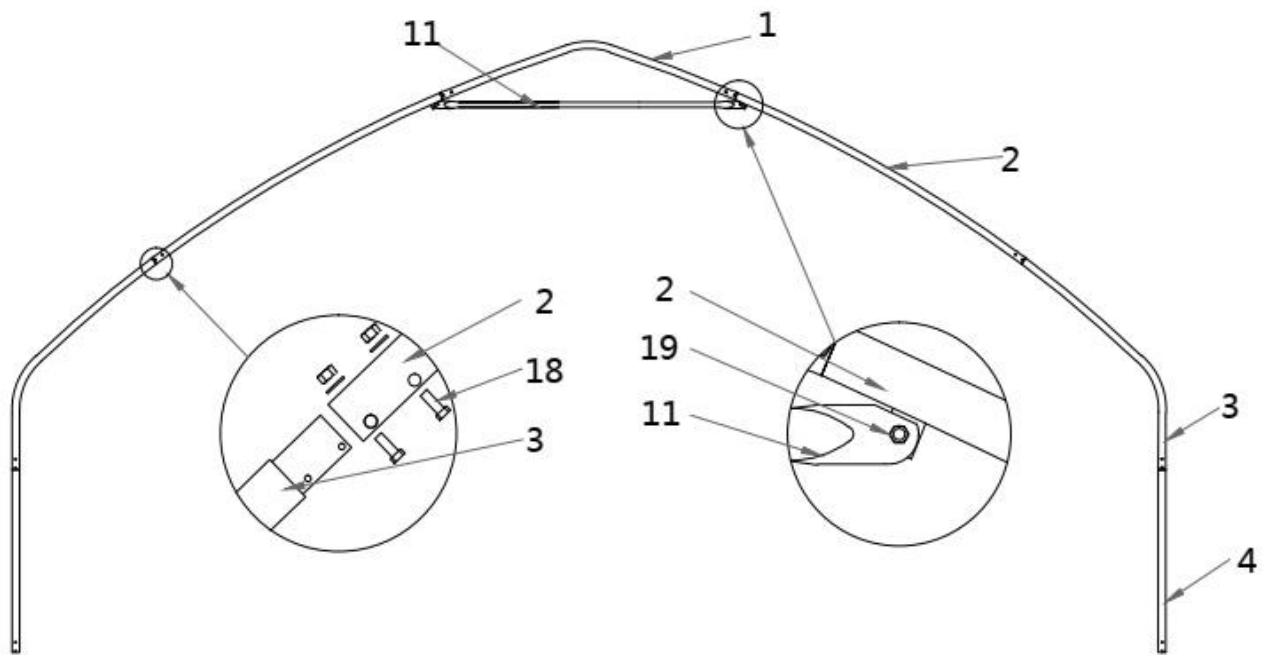

Picture 3

- Lay down all (11) trusses on the ground as figure 4 when the assembly is all completed and before moving to next step, and then scratch resistant tape (#26) around the sharp points of the joint to avoid friction between the fabric and the interface, resulting in fabric damage.

- (4) Scratch resistant tape (#26)

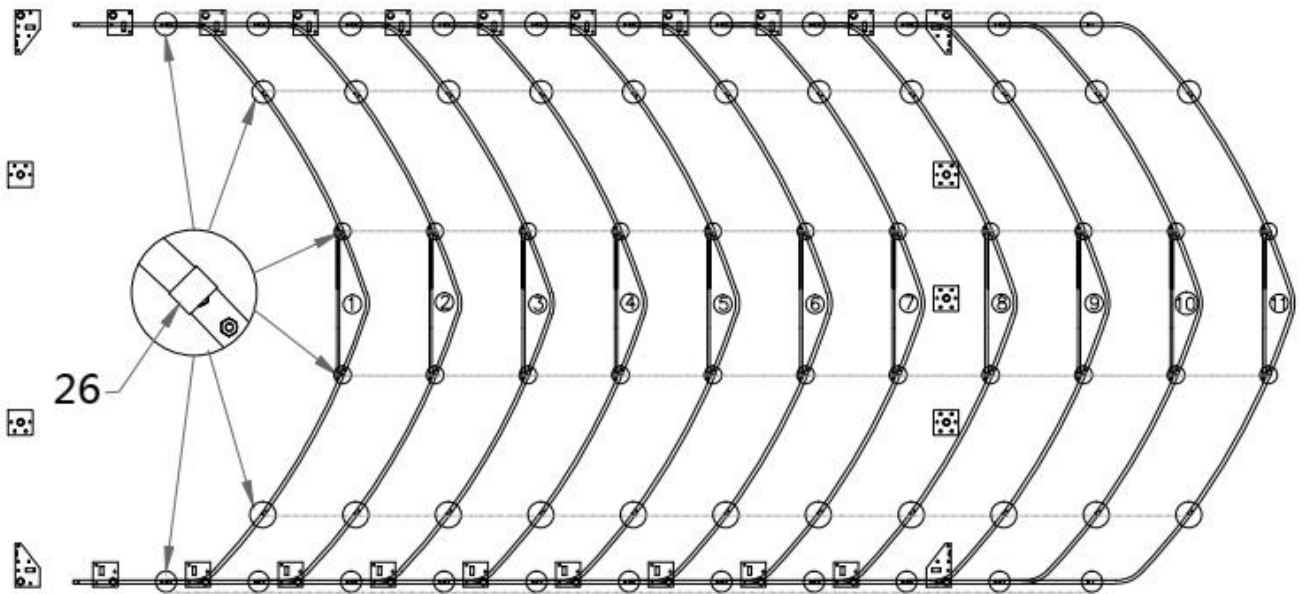

Picture 4

Step 3 : Put up the front (1st) truss

- Use of a crane or forklift is recommended, otherwise a team can use ropes to lift the trusses, but you have to make sure it is safe, and have enough manpower. We recommend 3 to 5 people to pull the truss up from different directions. When the truss is up, tie the ropes to the heavy objects to make sure the truss will stay upright and use bolt (#18) to connect the truss to the baseplate on both sides (picture 5).
- Parts used in this step : (4) Half round head bolt (#18)

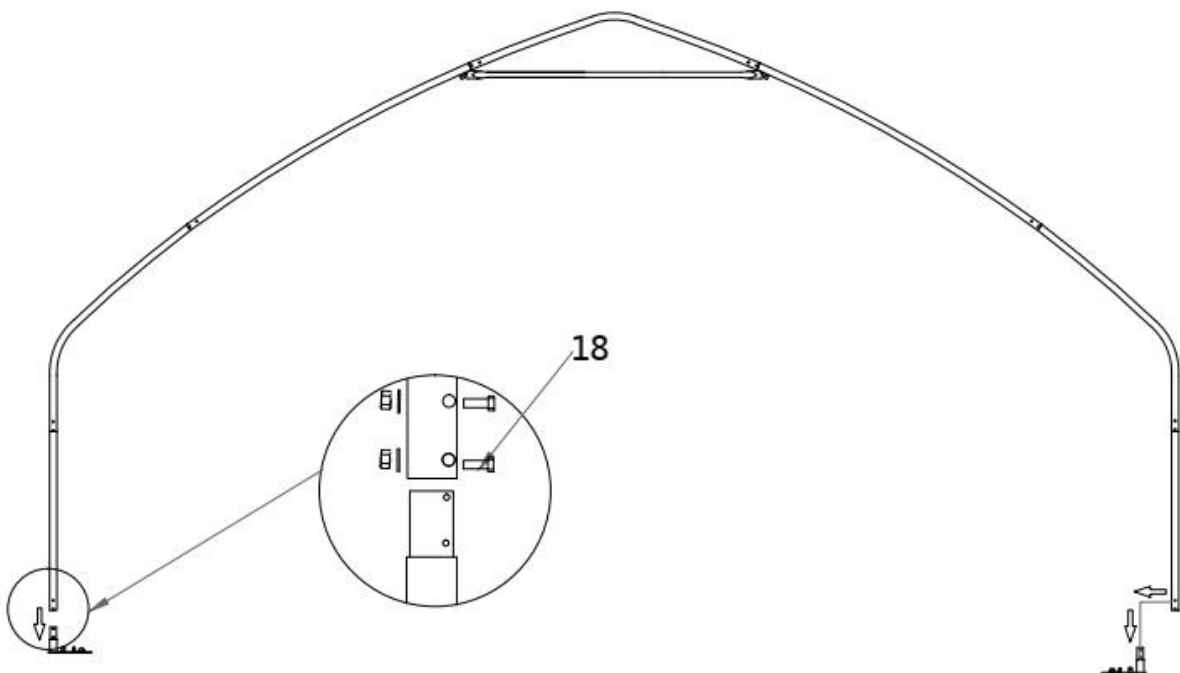

Picture 5

Step 4 : Put up the rest trusses

- Refer to Step 3 to put up the rest trusses, connect all 9 roof purlins (#5) with bolt (#17) and secure all bolts firmly on each span before going to next truss (picture 6).
- Parts used in this step :
 - (90) Roof purlin (#5)
 - (162) Middle truss connectors (#5A)
 - (18) Front and rear connectors (#5B)
 - (99) Self-tapping screws (#5C)
 - (180) Self-tapping screws (#17)

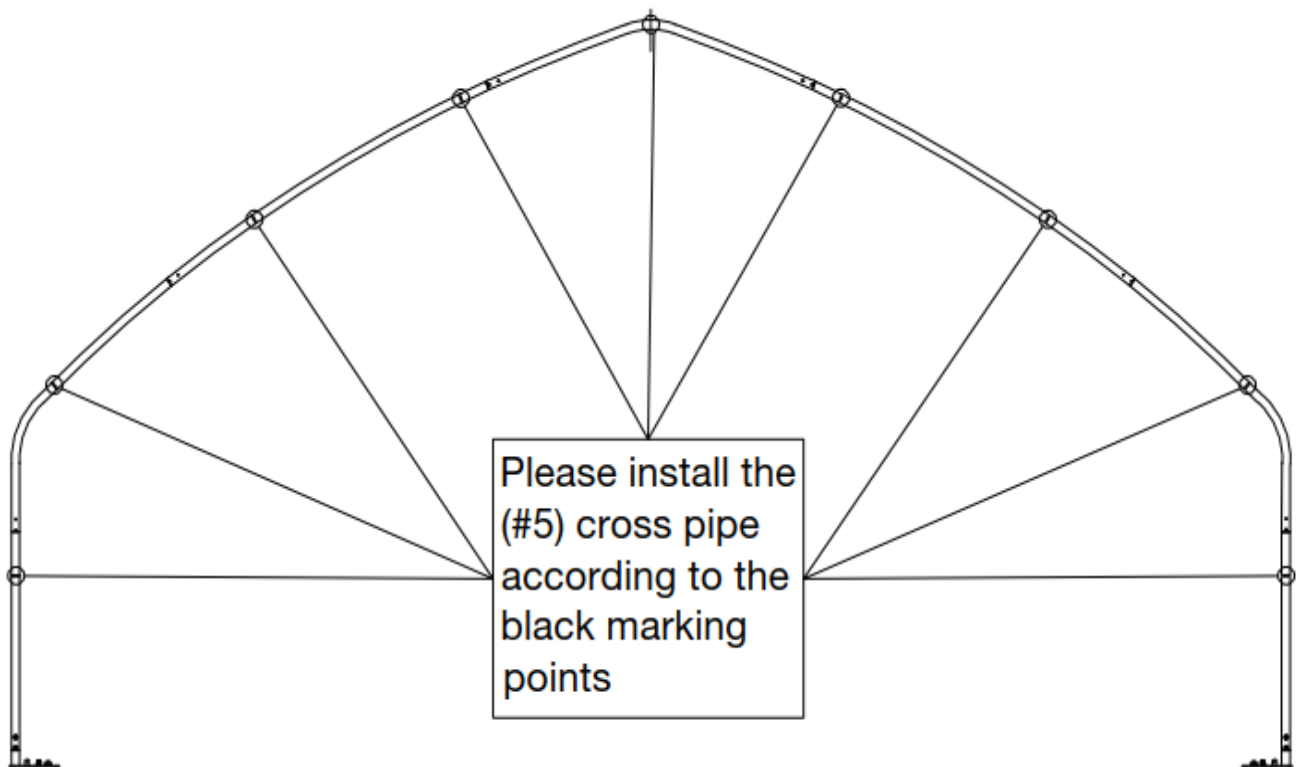

Picture 6-1

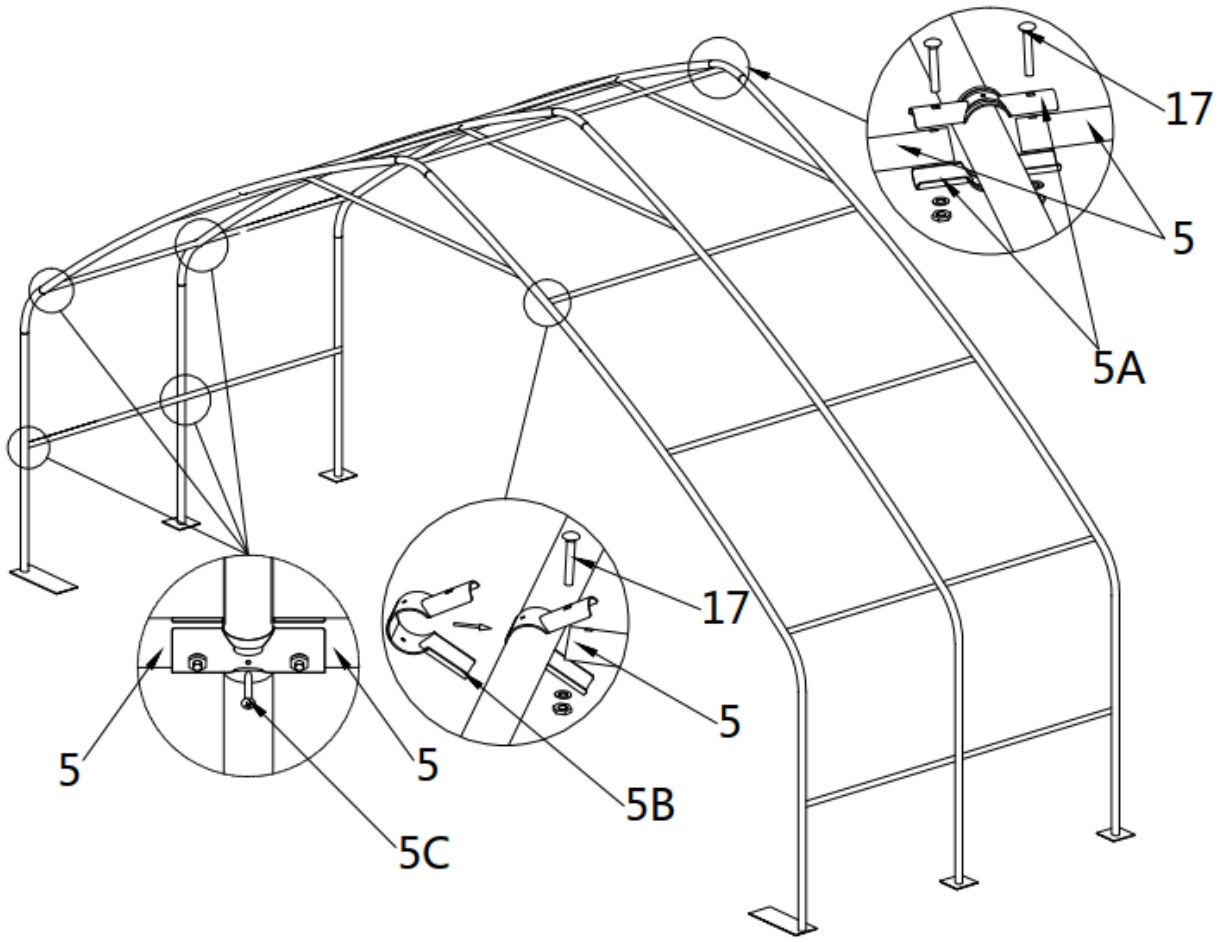

Picture 6-2

Step 5 : Install the diagonal bracing bars (#13)

- Connect diagonal bracing bar (#13) on the first and last span between the shoulder tube and sidewall tube (#3A and #4) with tube clamp (#13A), use bolt (#19A) (picture 7).
- Parts used in this step :
 - (2x2) Diagonal bracing bars (#13)
 - (4x2) Tube clamps (#13A)
 - (4x2) Bolts (#19A)

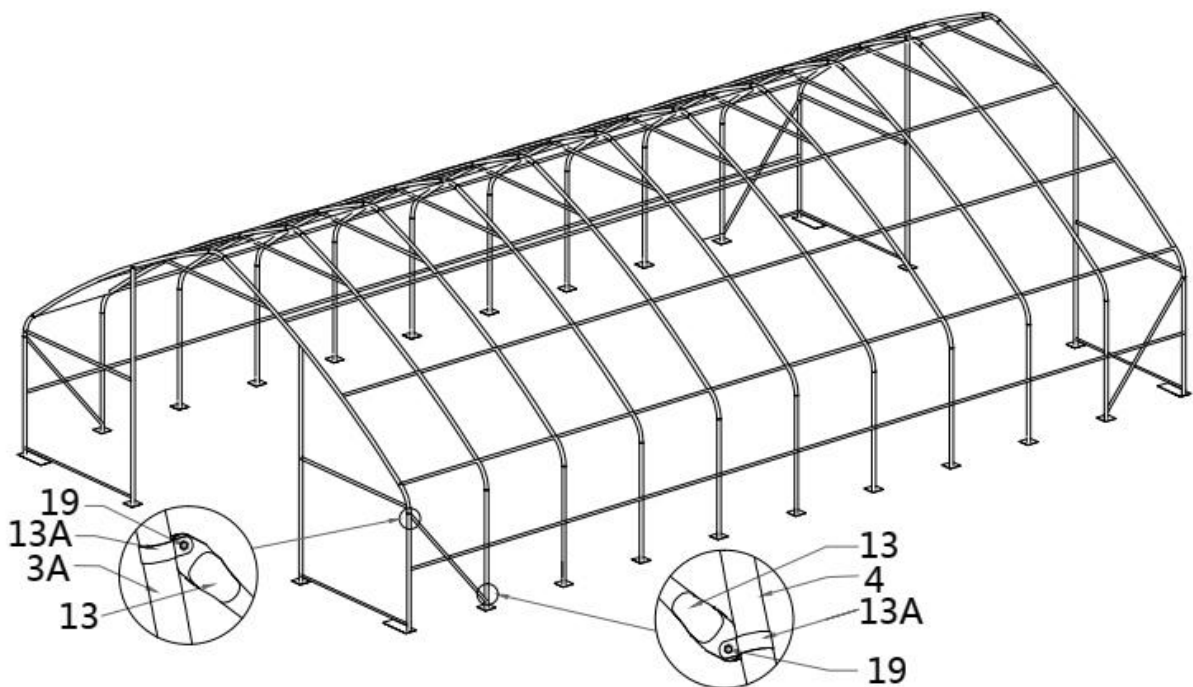

Picture 7

Step 6 : Install the remaining parts on the front and rear truss (picture 8)

- Parts used in this step :
 - (2x2) Door frame upper tube (#9)
 - (2x2) Door frame lower tube (#8)
 - (2x2) Door frame horizontal tube (#10)
 - (2x2) Bottom tension bar (#12)
 - (8x2) Half round head bolt (#18)
 - (4x2) Hex bolt (#19)

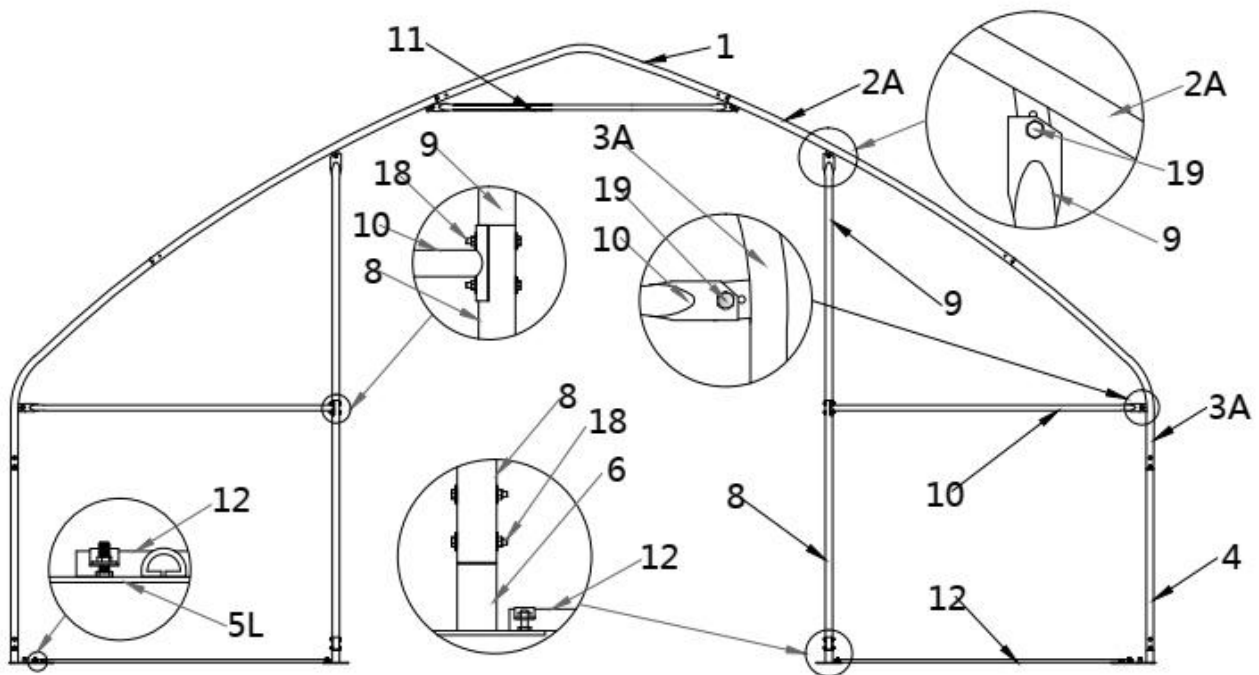

Picture 8

Step 7 : Install front and rear cover panel

- The door cover must be zipped. Use rope (#24) to lift up the front and rear cover (#23) from the center grommet and tie it firm to the truss tube and spread toward both sides through each grommet along the tube.
- Insert the dropping tube (#15) into the bottom groove pocket on the door cover. Tie two ropes (#20) separately on both sides of the peak arch tube. Pull both ropes under through the bottom of the door cover from the back, then go up from front and through both pulley 11A and 11B (Picture 9 & 10).
- The rope coming out from pulley 11B must go through the upper wheel of pully 11A, then pull both ropes together slowly and start to lift the door cover.
- Tie both ropes to the corner baseplate. Now the door cover is up. When you drop down the door cover, do not let go too quick, otherwise it might get stuck and damage the fabric.

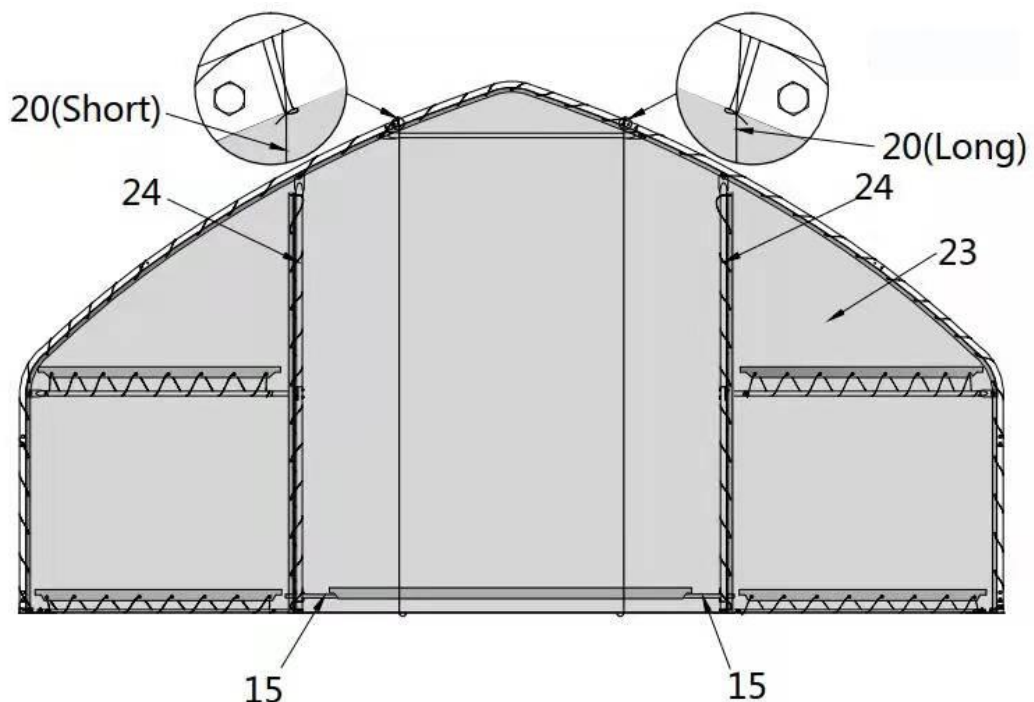

(Picture 9-view from inside)

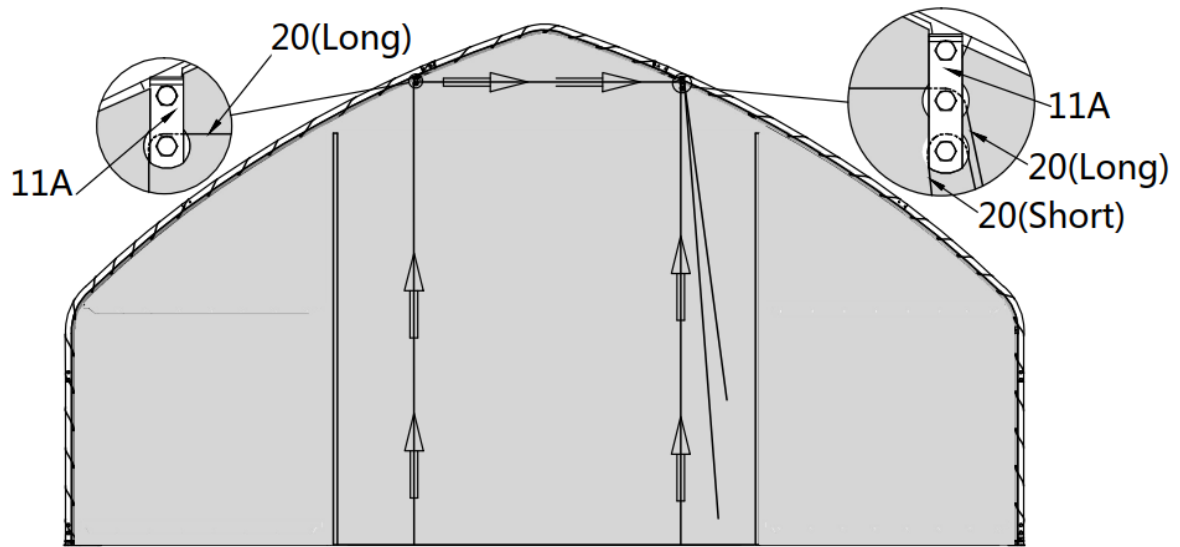

Picture 10

Step 8 : Install the top cover (#22)

Do not install the cover during windy weather !

- Unpack the top cover and place it along one of the long sides of the structure.
- Use 3 to 5 braided rope (#24) to pull the top cover (#22) the top of the structure, 2 or 3 people standing inside on ladders to push upwards will help to move the cover smooth without any damage (picture 11).

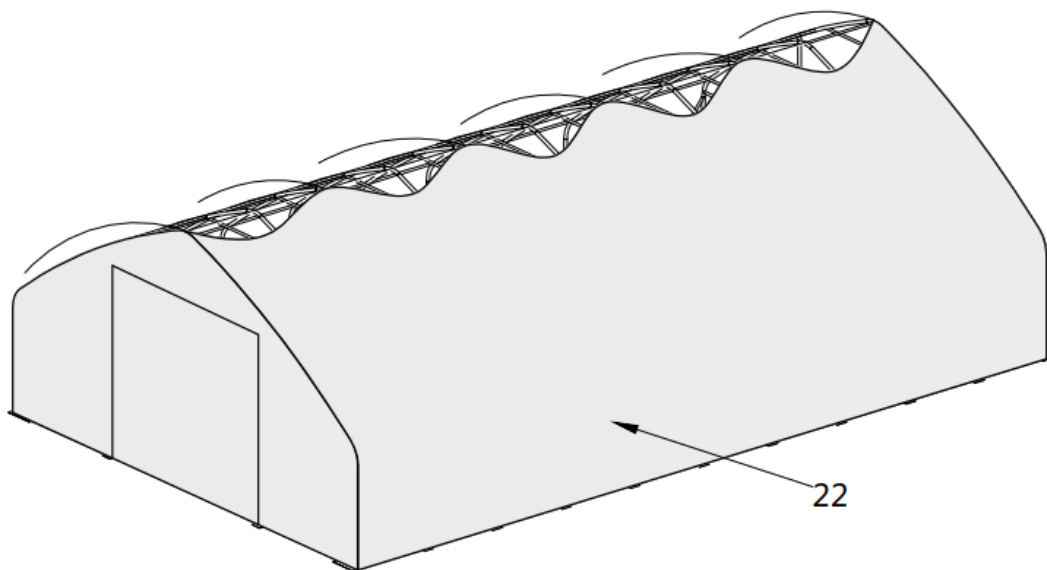

Picture 11

Step 9 : Stretch and tighten top cover

- The roof cover must be stretched and tied to the front and rear truss by rope going through the flap grommets on the cover. Start from the top center and go toward both side on each end. Add or cut the rope as needed.
- Pull and stretch the cover enough only to take wrinkles out. Repeat for the rear truss. Do not over stretch as it could rip off the grommets (picture 12).

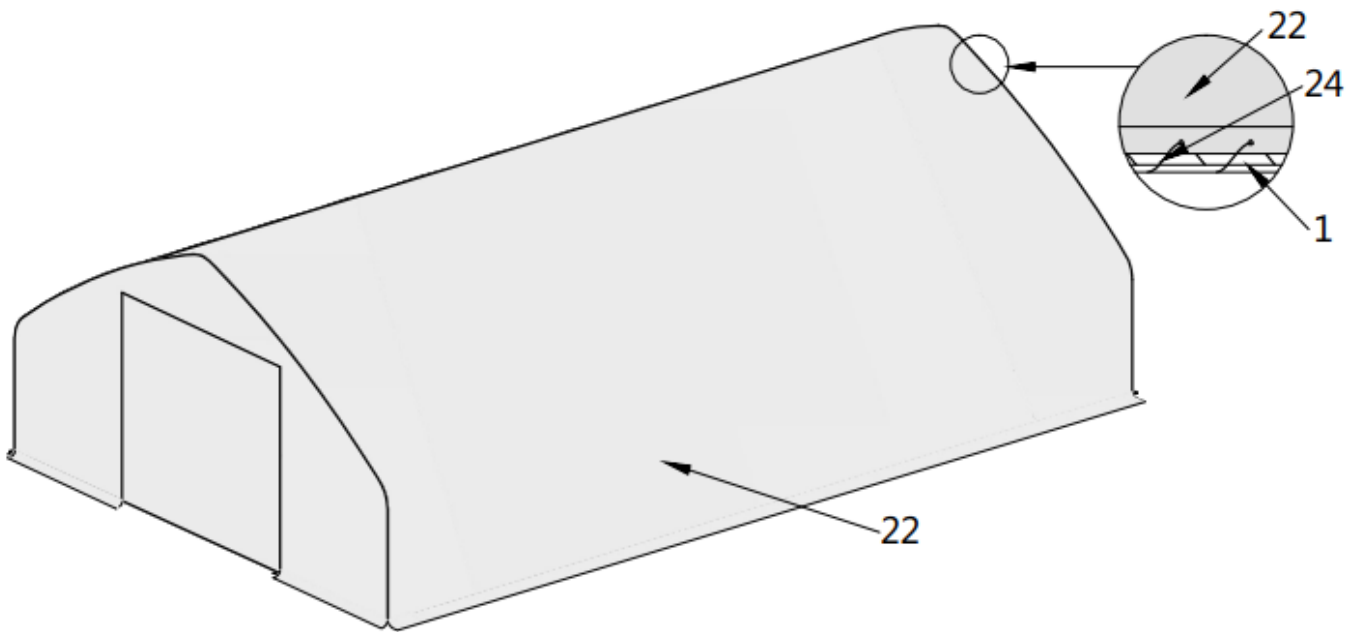

(Picture 12-view from outside)

Step 10 : Tension the cover on the structure from both sides (picture 13)

- Insert tension tubes (#14) slowly into the bottom groove pocket on both long sides. Add the water plug (#21) on the first tension tube to avoid tearing the fabric and add one to the end of last tube as well.
- Repeat the same step for the other side.

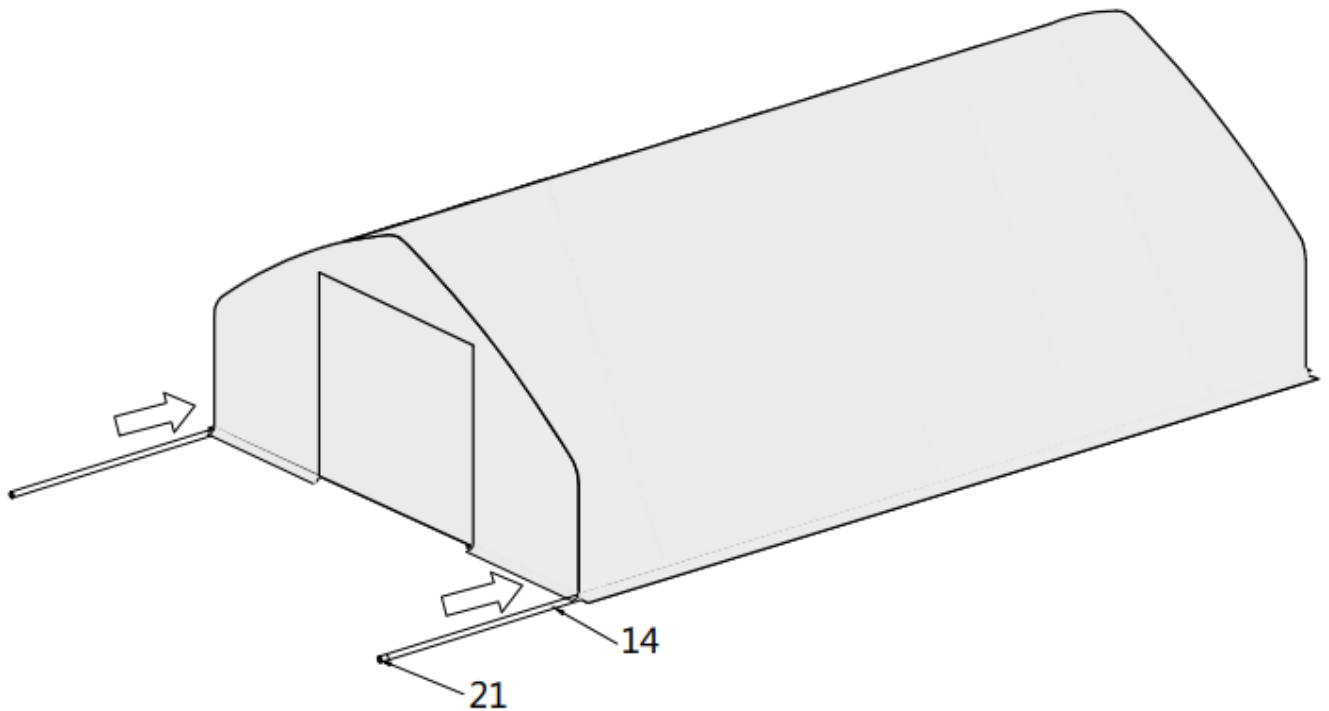

Picture 13

Step 11 : Install ratchet straps (Picture 14)

- Stretch and adjust the cover from left and right, back and forth, to make sure it is square and centered. Cut the groove pocket where it aligns with ratchet (#7A), and use tie down straps (#25) to pull tension tube (#14) toward the ratchet and tie it firmly there.
- Evenly adjust all ratchets on both sides to take wrinkles out and make the cover flat and smooth.
- Parts used in this step :
 - (22) Tie down straps (#25)
 - (22) Ratchet (#7A)

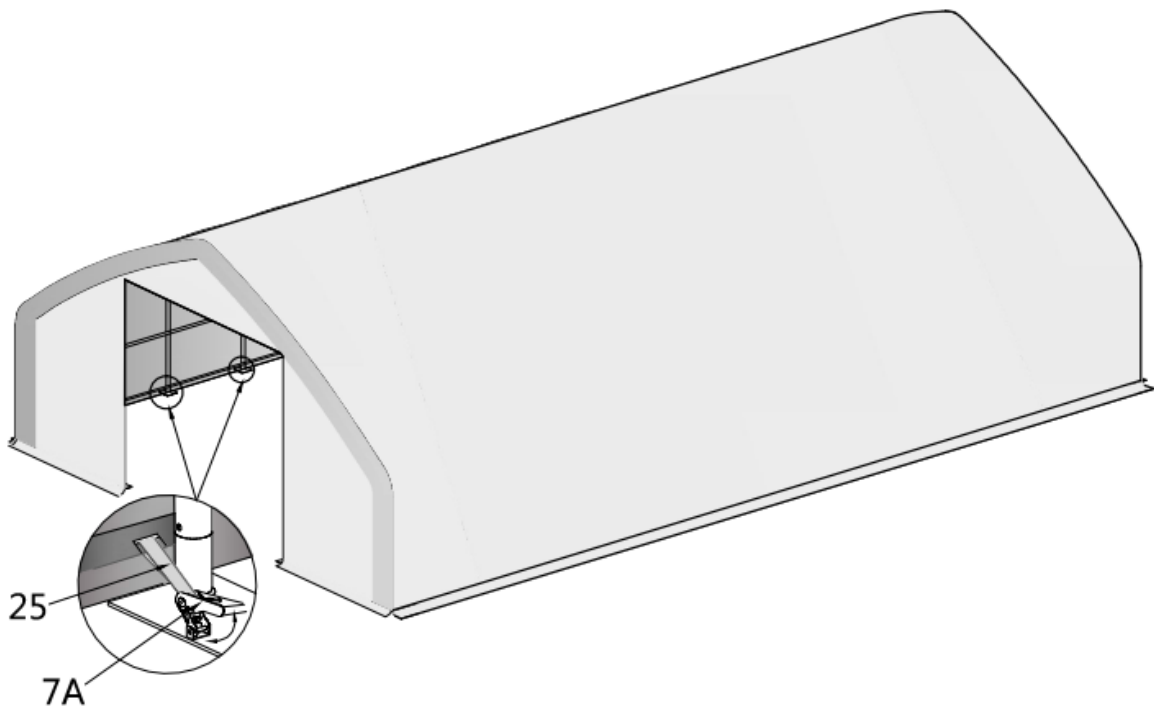

Picture 14

After the Installation

Walk around and inspect the shelter periodically to make sure all components are still firmly secured and the whole shelter is well supported. Check all bolts and nuts as well as all connection points to make sure they are all in good position. Check the base plates, adjust the ropes and tie downs if required and clean the cover regularly.

Snow accumulating on the fabric cover must be removed as soon as possible. If snow becomes solid ice on the cover, it will increase the weight on the roof and may collapse the shelter or reduce the life span.

Keep the shelter on a dry ground most of the time. Do not keep the fabric dirt skirt under water all the time, otherwise the fabric will deteriorate.

We strongly recommend you remove any snow from the roof immediately. Do not leave any snow load on the roof overnight. Keep 3 feet of clearance on all sides at all times. Do not allow snow to accumulate and pile up on the sides of the building. Otherwise the pressure from the sides will push inwards and could lead to a collapse.