

MODEL TMG-ST3041CVF

30' X 40' PVC FABRIC CONTAINER PEAK ROOF SHELTER PRO SERIES

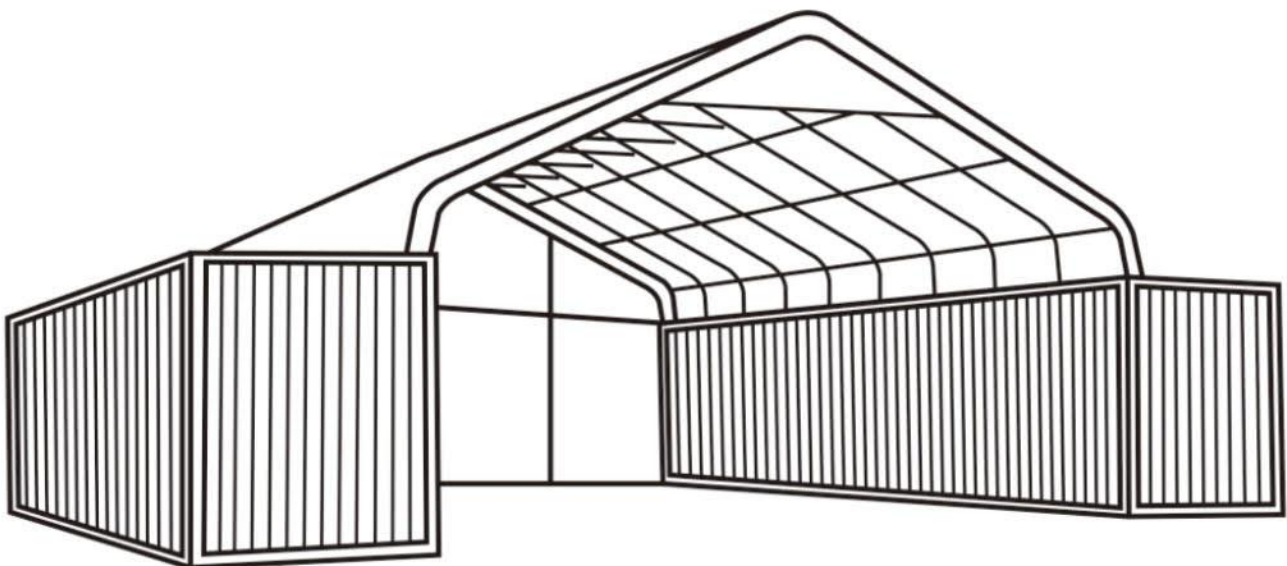

⚠ WARNING

- Please read and understand the product manual completely before assembly
- Check against the parts list to make sure all parts are received
- Wear proper safety goggles or other protective gears while in assembly
- Do not return the product to dealer. They are not equipped to handle your requests.

Missing parts or have questions on assembly?

Please call: 1-877-761-2819 or email: cs@tmgindustrial.com

Main Specifications :

- Overall assembled size : W9.15 x L11.97 x H3.0 (m) / 30 x 39.27 x 9.84(ft)
- Ridge Peak Height : 3 m / 9.84ft + container height

Prior to assembly

Please read the instructions carefully before installation. It is very important to follow your local safety regulations and industry standards during installation. Regulations may include but are not limited to:

- Safety helmets, protective eyewear, and clothing
- Safety harnesses for all elevated workers
- Proper ladder, cage, and safety operation

Check all components and parts before installation. All parts are marked with a part number, please refer to the parts list to make sure you have all parts.

Choose a day with low or no wind to install, assembly is hard in heavy wind. Do not make any alterations to the structure. Do not hang any weights on the frame during installation, including parts. We are not responsible for any damages or injuries caused by inappropriate installation, unauthorized modifications or extreme weather.

This building is not intended for human occupancy.

It is recommended to tape or add foam/rubber on the frame where joints connect and where it touches the cover. This will help extend the life span of the cover.

Read the following item list carefully and count the number of items to ensure that all parts are included prior to setup.

Installation steps

Step 1 : Review the whole structure and choose the proper installation site

Choose a solid flat level ground area to set up the building. Do not install the building on soft ground, wetland, uneven surfaces, sloped surfaces, or on top of structures that are not rated to hold its weight.

We strongly recommend that you put the containers on hard foundations before installing the shelter.







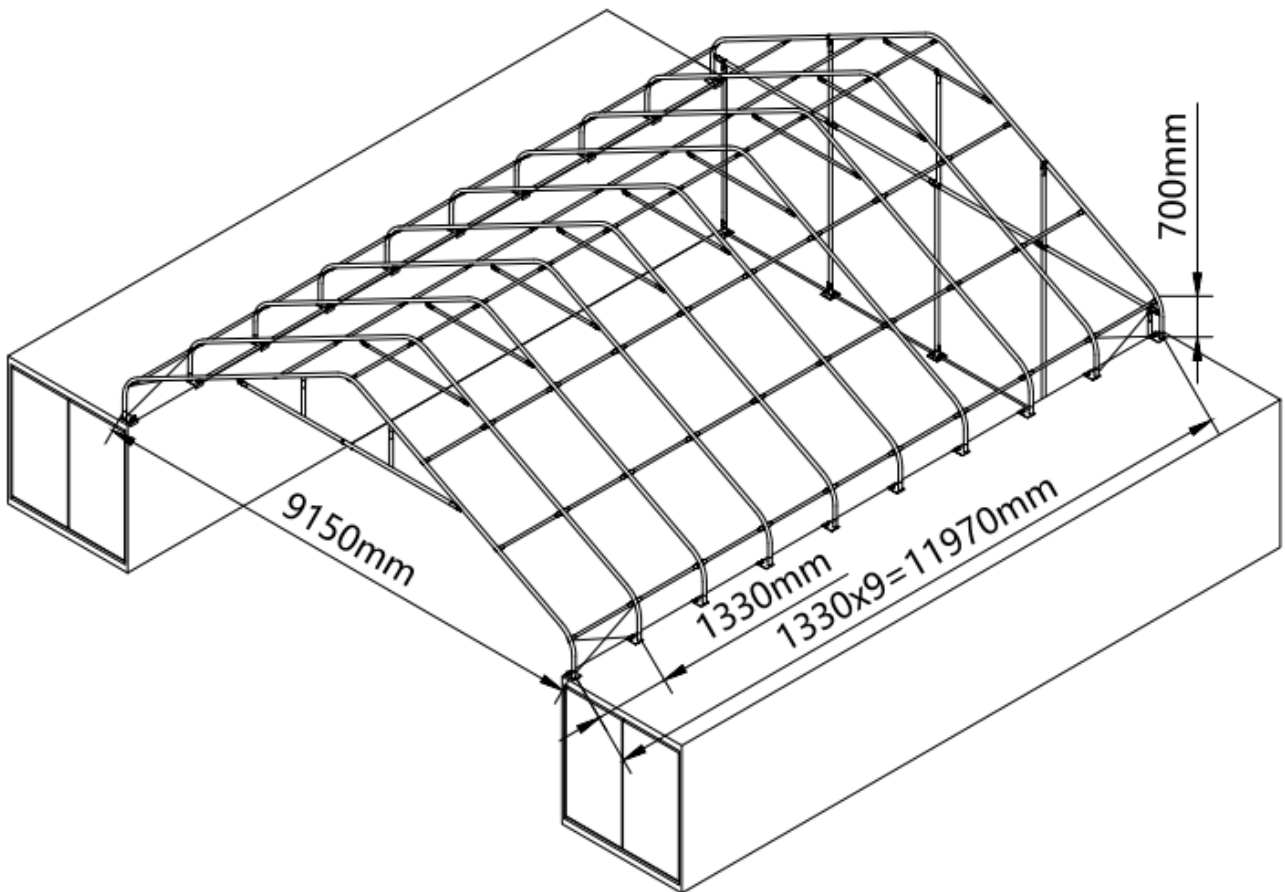

Be aware of the surrounding area. Do not set up the building near snowdrifts, open flames or exposed electrical wires. Do not keep heat sources near the fabric cover. Keep the building surroundings clear at all times.



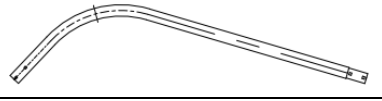
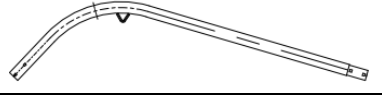
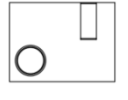
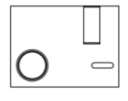
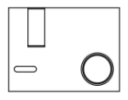
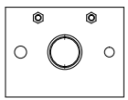
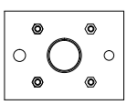



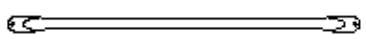









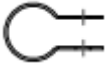

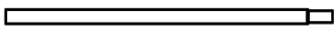
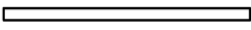
(picture1)









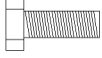

Structure diagram

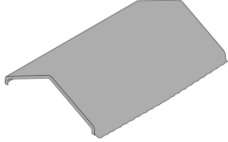

TMG-ST3041CVF Part List

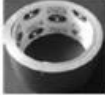
No.	Picture	Description	Length	Quantity
1		Peak arch tube	L1734mm	10
2		Middle rafter tube	L2890mm	18
2A		Middle rafter tube	L2890mm	2
3		Shoulder tube	L1784mm	12
3A		Shoulder tube	L1784mm	8
4		Middle truss base plate	W150xL200mm	16
4L		Left corner base plate (front and rear truss)	W150xL200mm	2
4R		Right corner base plate (front and rear truss)	W150xL200mm	2
4A		Base plate (front and rear door)	W150xL200mm	2
4B		Base plate (front and rear door)	W150xL200mm	3
5		Roof purlin (horizontal tube)	L1268mm	63
5A		Middle truss connectors ($\phi 58/\phi 42$)	W50xL180mm	112
5B		Front and rear connectors ($\phi 58/\phi 42$)	W50xL121mm	14
5C		Self-tapping screws (#12x25mm)	#12x25mm	70
6		Ceiling cross bar	L2190mm	9
6A		cross-draw tube (For front arch pipe)	L2318mm	1





6B		cross-draw tube (For front arch pipe)	L2313mm	1
6C		vertical tube (For front arch pipe)	L590mm	2
7		Sidewall frame steel tension cables	L1300mm	8
7A		Ratchet	2T	20
7B		Ratchet straps	W38xL800mm	20
8		Mounting base	W40xL100mm	8
8A		Tube clamp	φ42	3
8B		Tube clamp	φ58	6
9		Top cover tension tube (for both bottom sides)	L1993mm	12
9A		Top cover tension tube	L490mm	2
10		Front and rear lower columns	L2775mm	3
10A		Front and rear upper columns	L1785mm	2
10B		Front and rear columns	L2660mm	2
10C		Front and rear upper columns	L2206mm	1
11		Door frame upper tube	L2512mm	2
11A		Door frame upper tube	L1970mm	2
12		cover tension tube	L2250mm	2
12A		cover tension tube	L1910mm	2
14		Bolt M8x60	M8x60mm	126



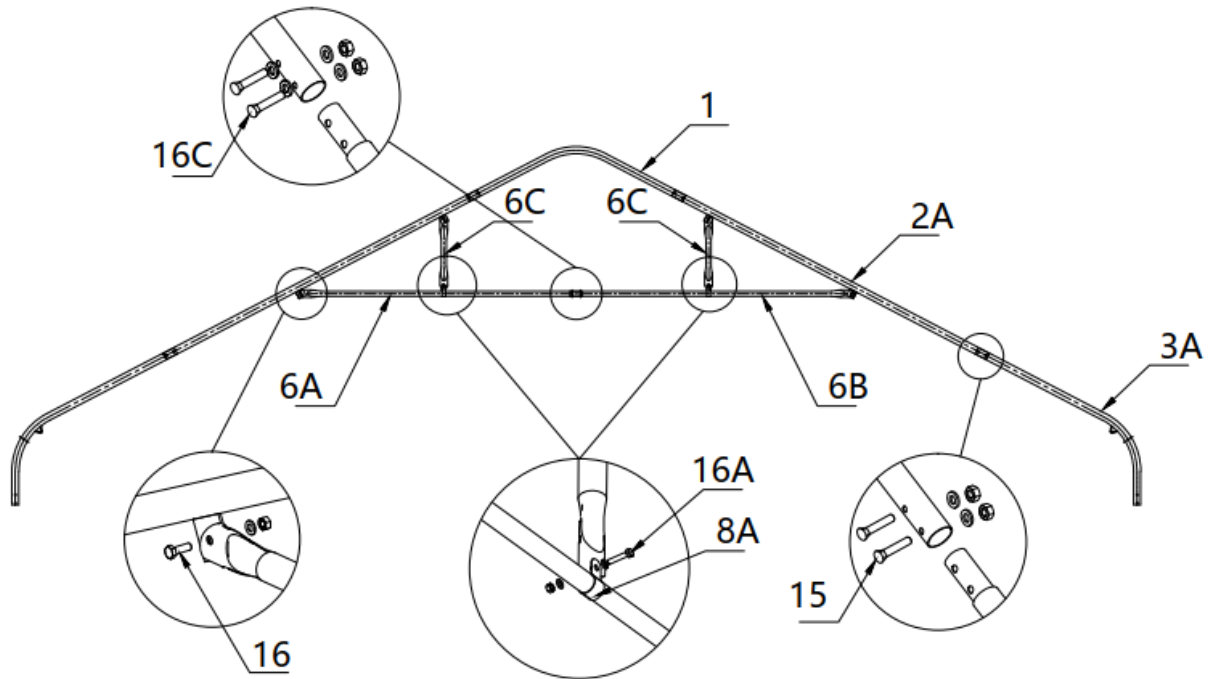

15		Bolt M8x70	M8x70mm	130
16		Hex bolt M10x30mm	M10x30mm	22
16A		Hex bolt M10x50mm	M10x50mm	9
16B		Hex bolt M8x80mm	M8x80mm	6
16C		Hex bolt M8x60mm	M8x60mm	2
17		Expansion bolt ϕ 16x150mm	ϕ 16x150mm	10
18		Top cover		1
19		Braided rope (140m)	ϕ 8x140m	1
20		Scratch resistant tape	10m	2
21		Water plug	ϕ 32	12
22		Front cover panel		1
23		Rear cover panel		1

Step 3 : Connect all trusses.

- Front trusses (1trusses).



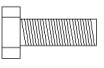
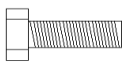

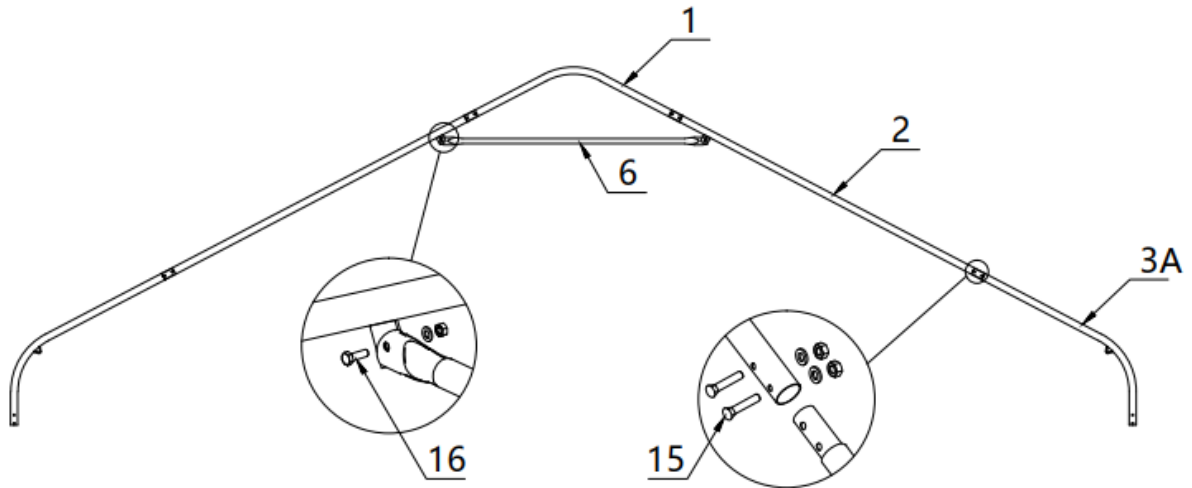

No.	Part	Qty
1		1
2A		2
3A		2
6A		1
6B		1

No.	Part	Qty
6C		2
8A		2
15		8
16		4
16A		2
16C		2

- Front and rear trusses (3trusses).



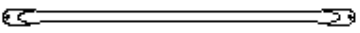

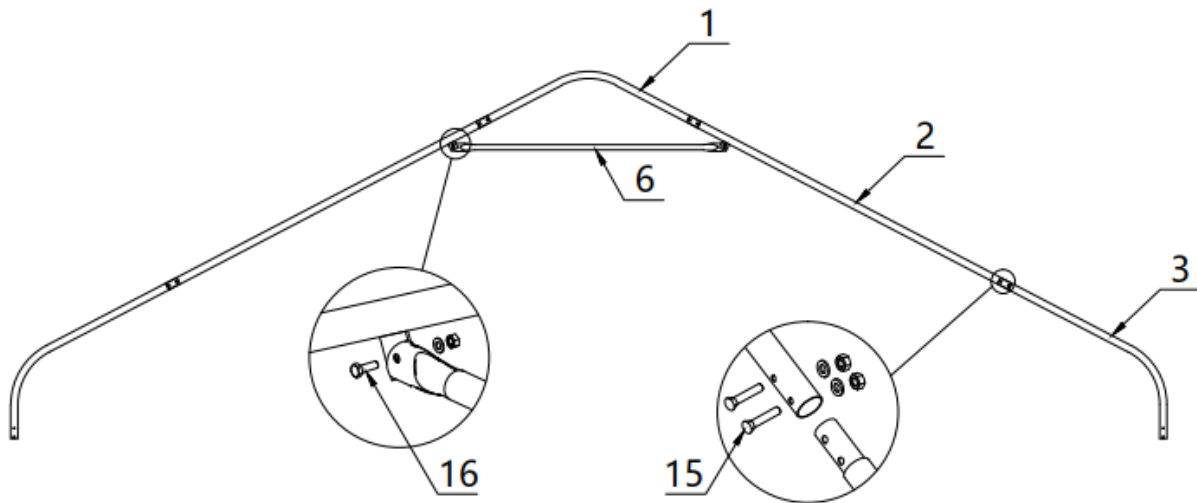

No.	Part	Qty
1		1x3
2		2x3
3A		2X3

No.	Part	Qty
6		1x3
15		8x3
16		2x3

Middle trusses (6 trusses).

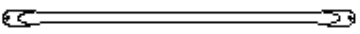

No.	Part	Qty
1		1x6
2		2x6
3		2X6

No.	Part	Qty
6		1x6
15		8x6
16		2x6

Lay down all (10) trusses on the ground when the assembly is all completed and before moving to next step, and then wrap (#15) around the sharp points of the joint to avoid friction between the fabric and the interface, resulting in fabric damage.

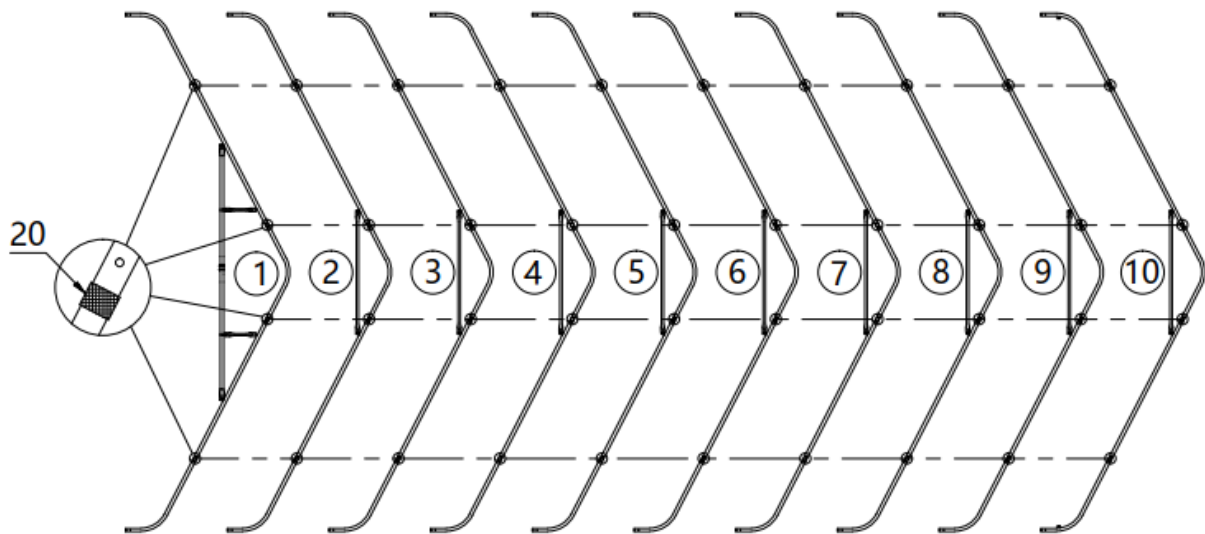

No.	Part	Qty
20		2

Step 4 : Put up all trusses.



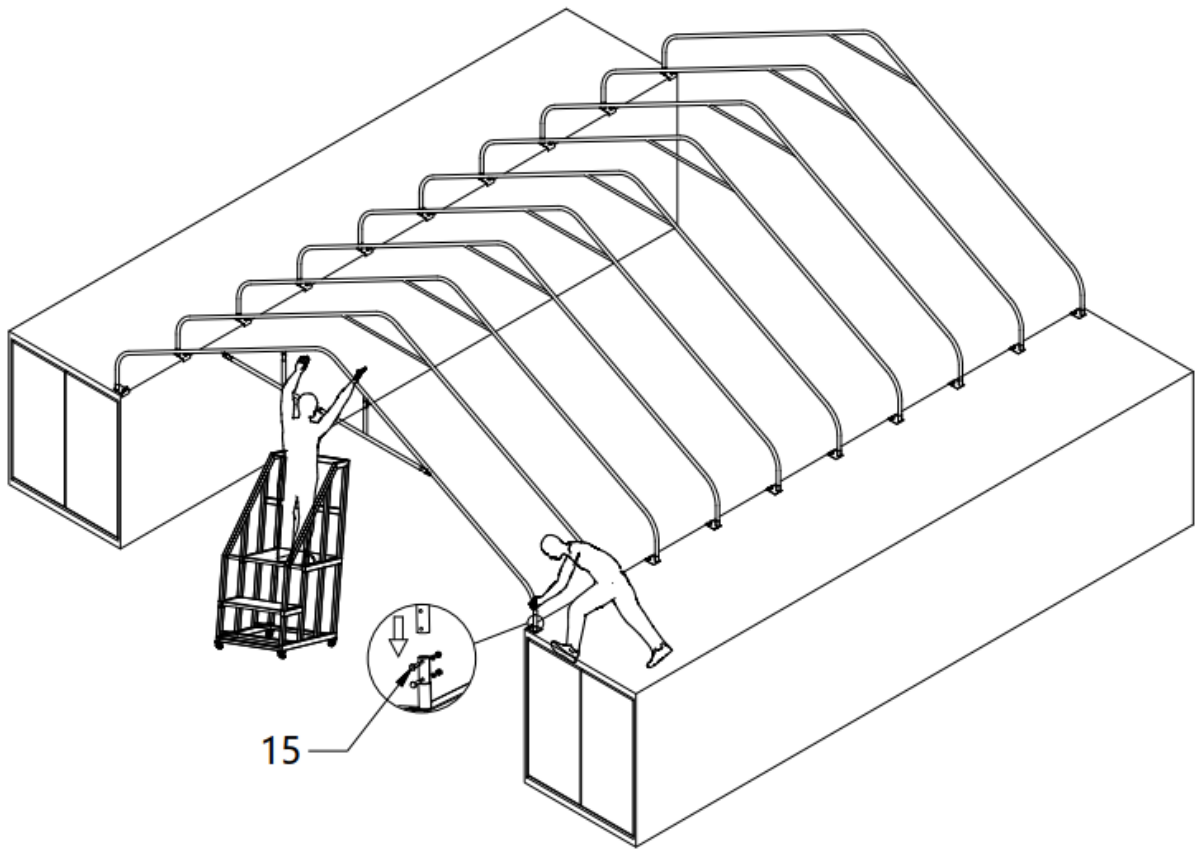

Install each truss on the base tube. Use hex bolt (#11) to secure the truss to the base tube firmly. We recommend to use a crane or forklift to lift the truss and have 2 to 3 people on site to work together. Please make sure it is safe and secure when installation is proceeding.



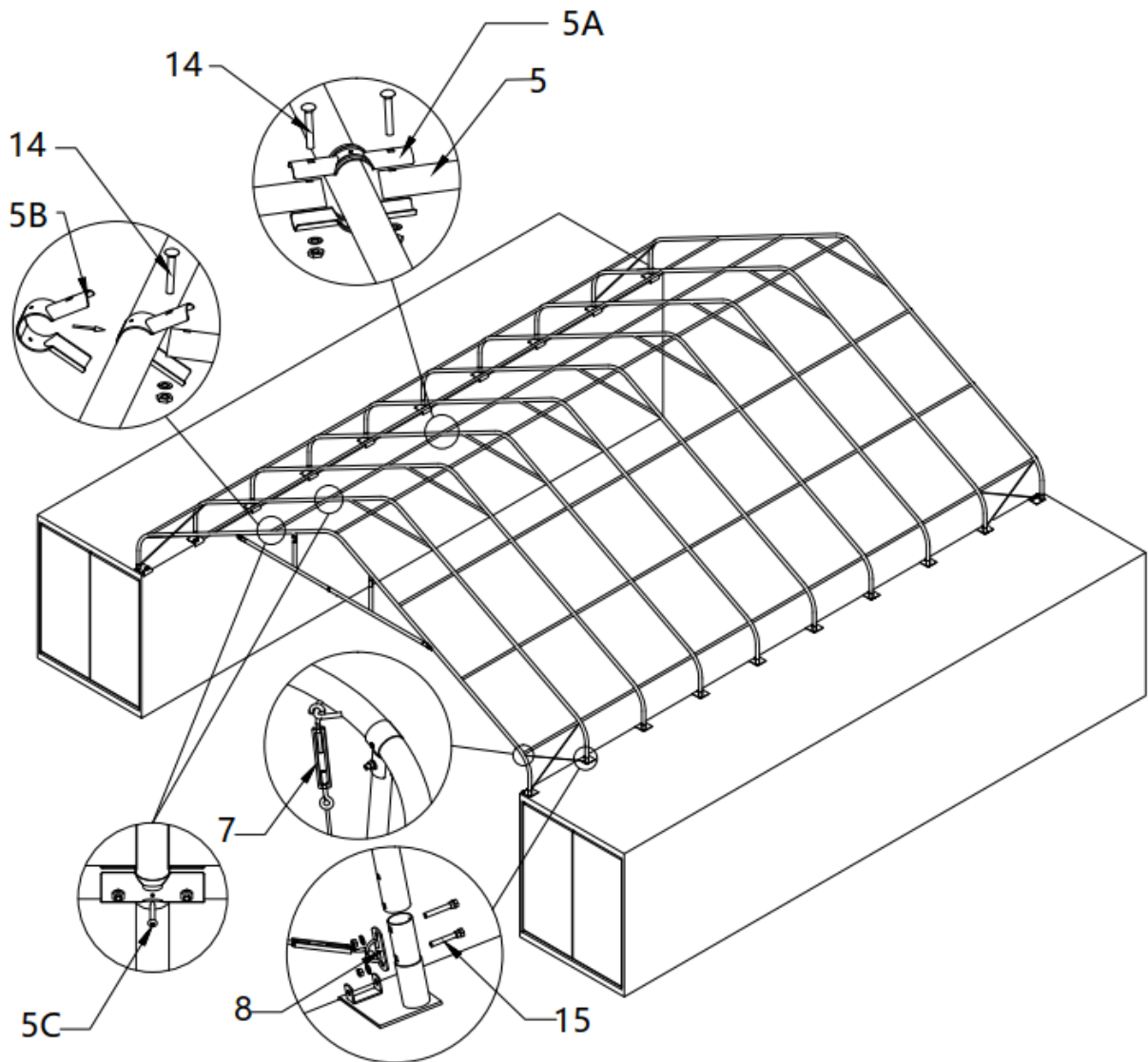

No.	Part	Qty
15		40

Step 5 : Install cross tubes and wire ropes.



No.	Part	Qty
5		63
5A		112
5B		14
5C		70

No.	Part	Qty
7		8
8		8
14		126

Step 6 : Install the remaining parts on the rear truss.

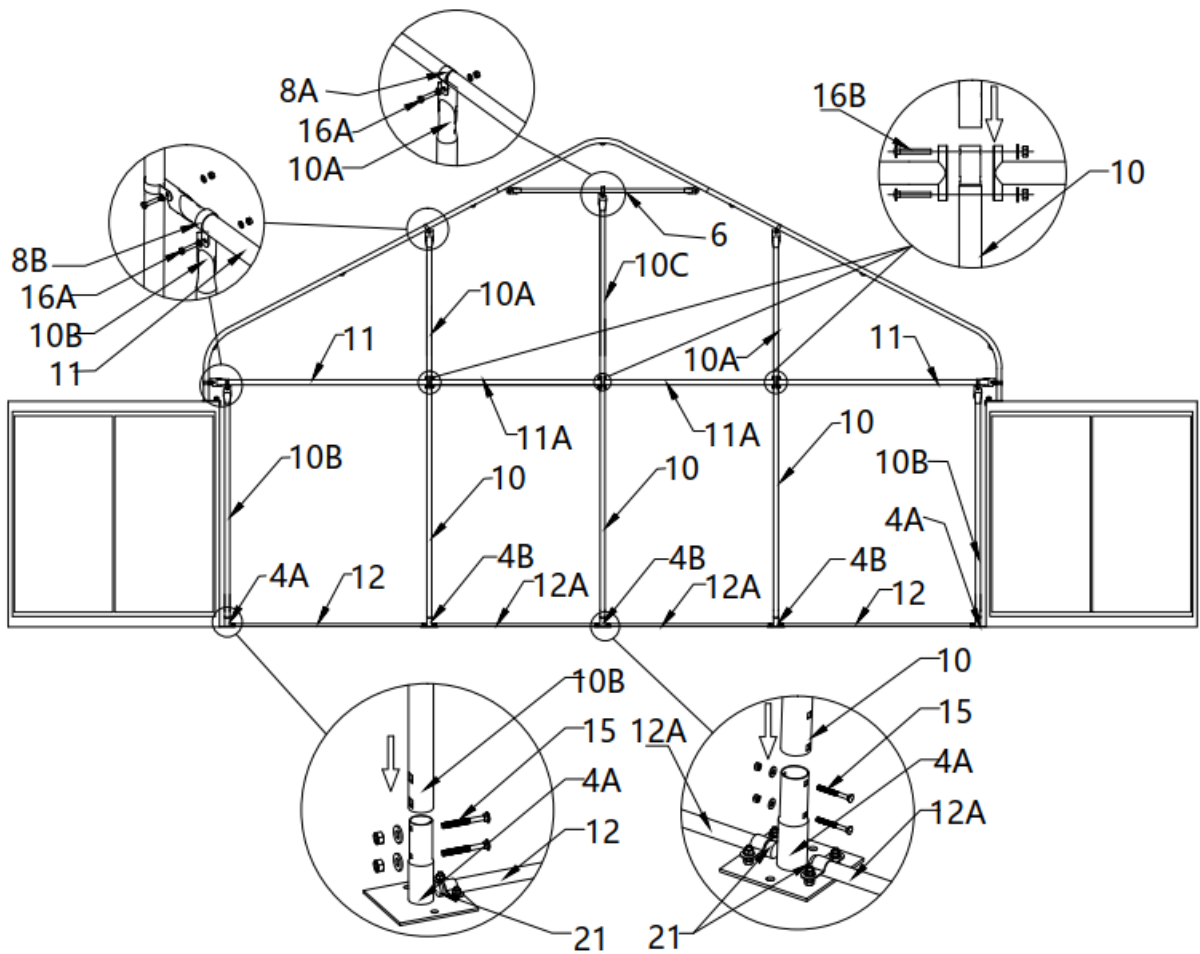

No.	Part	Qty
8A		1
8B		6
10		3
10A		2
10B		2
10C		1
11		2

No.	Part	Qty
11A		2
12		2
12A		2
15		10
16A		7
16B		6
21		8

Overall structural inspection :

Check all components and trusses to ensure the entire structure is rectangular as specified in (picture1). All trusses must be 90 degrees straight up from the container.



Secure and tighten all bolts and nuts on this step. But do not over tie! Otherwise you might damage the tubes or components.

Step 7 : Install front cover panel.

What you see in this picture is the inside!

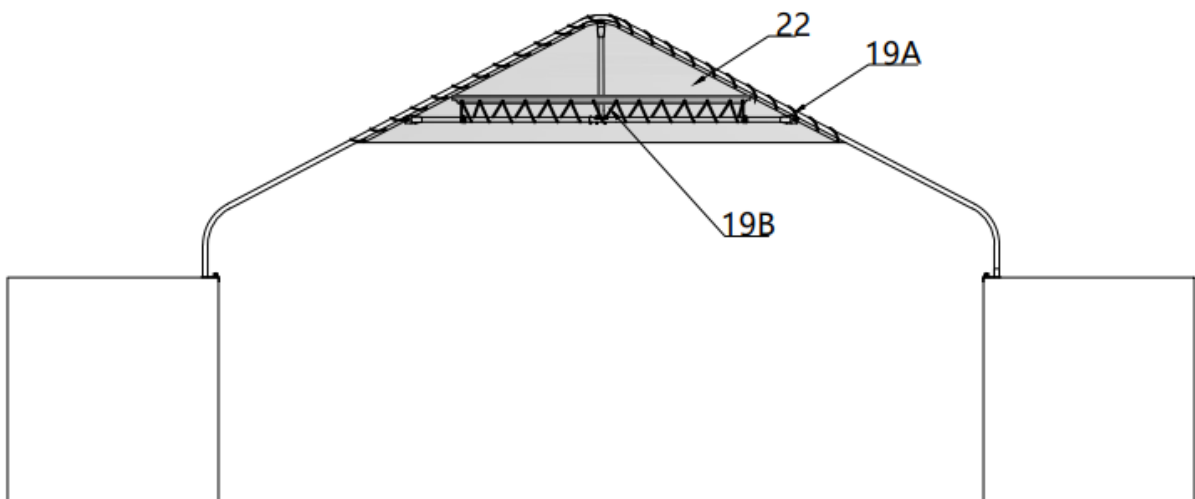
Lift up (#22) cover panels, starting from the center point of the frame (highest ridge point) use ropes (#19) through the grommets to tie the panel to the truss firmly. All grommets need to be tied to the frame.



NO.	Part	Qty
22		1
19		16m



Rope Shear Size		
19		Qty
A	10m	1
B	6m	1

Step 8 : Install rear cover panel

What you see in this picture is the inside!

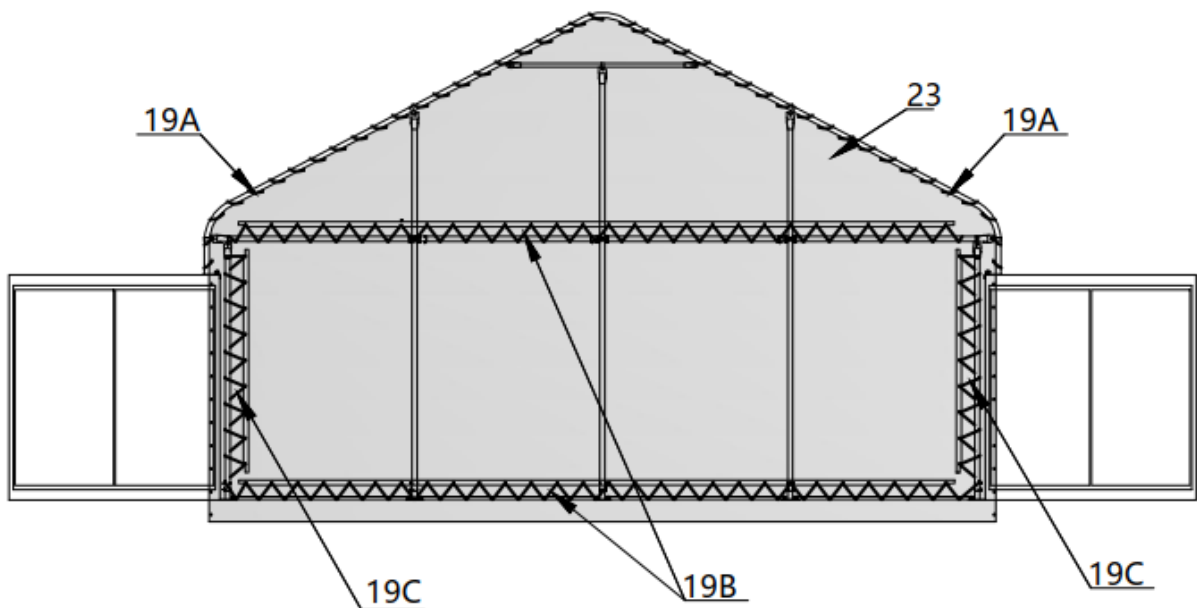
Lift up (#23) cover panels, starting from the center point of the frame (highest ridge point) use ropes (#19) through the grommets to tie the panel to the truss firmly. All grommets need to be tied to the frame.

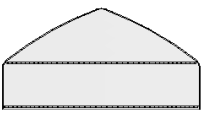

NO.	Part	Qty
23		1
19		56m

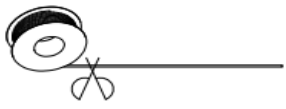
Rope Shear Size		
19		Qty
A	10m	2
B	13m	2
C	5m	2



Step 9 : Install the top cover (#18) stretch and tighten top cover.

Do not install the cover during windy weather!

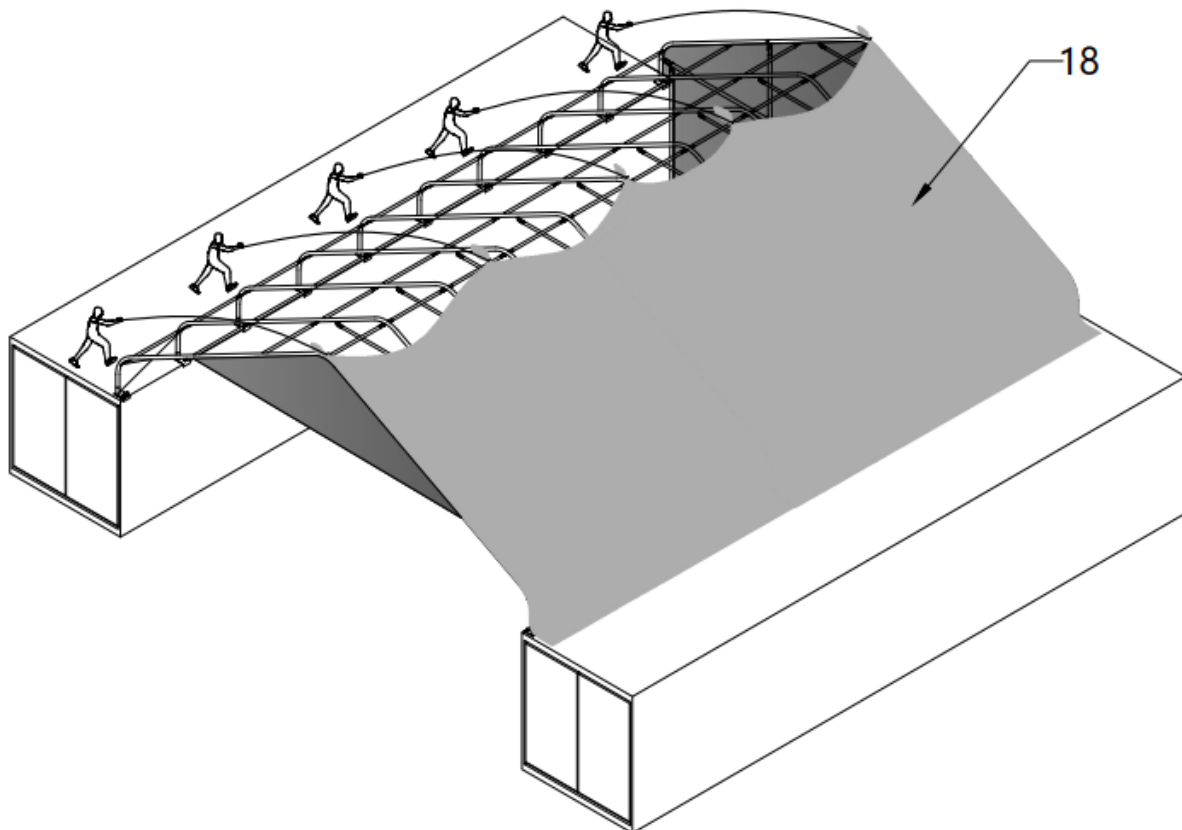
- Stretch and adjust the cover from back and forth, to make sure it is square and centered.
- Unpack the top cover and place it along one of the long sides of the structure.
- Use 3 to 5 ropes (#18) to pull the cover over the top of the structure, from the inside 2 or 3 people standing inside on ladders to push upwards will help to move the cover without any damage.

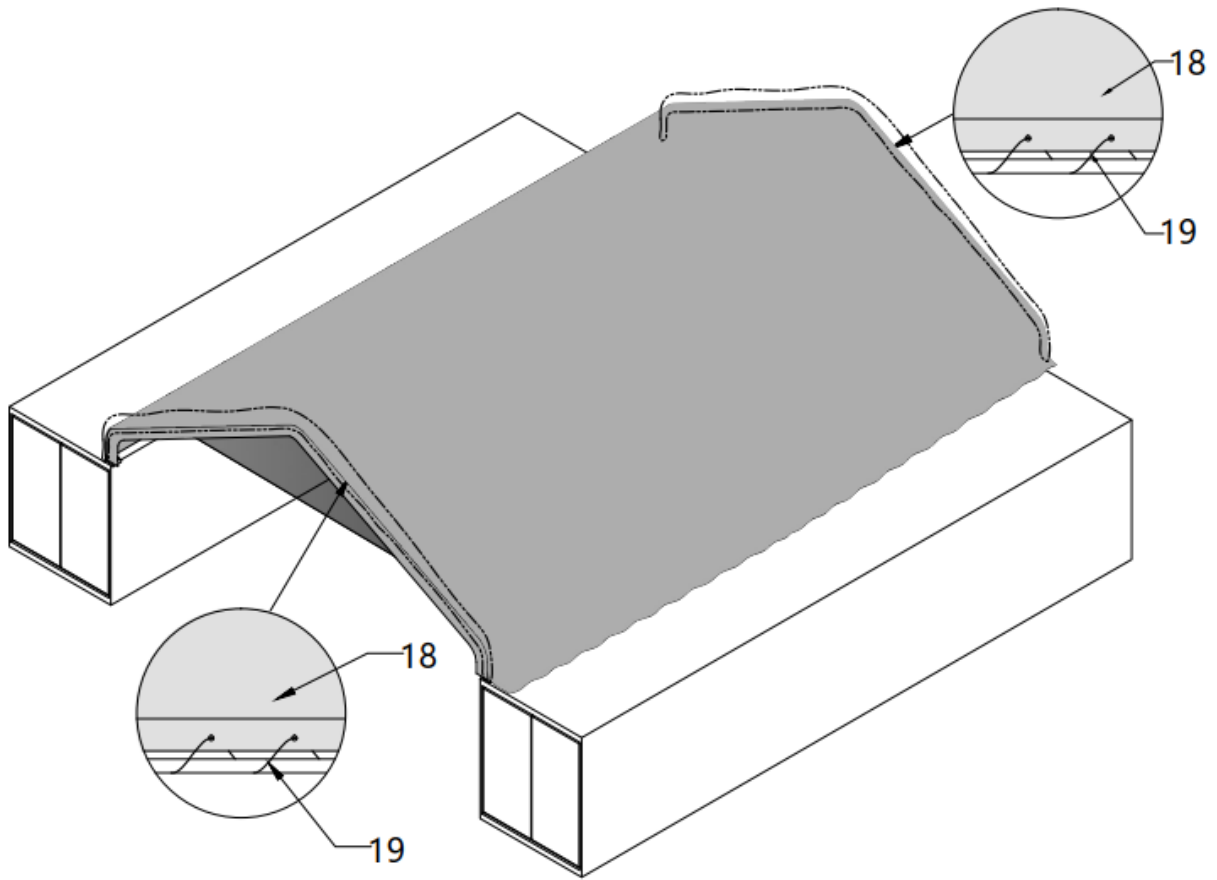

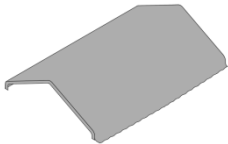



NO.	Part	Qty
18		1
19		40m

Rope Shear Size		
19		Qty
19	10m	4

Step 10 : Tension the cover on the structure from both sides.

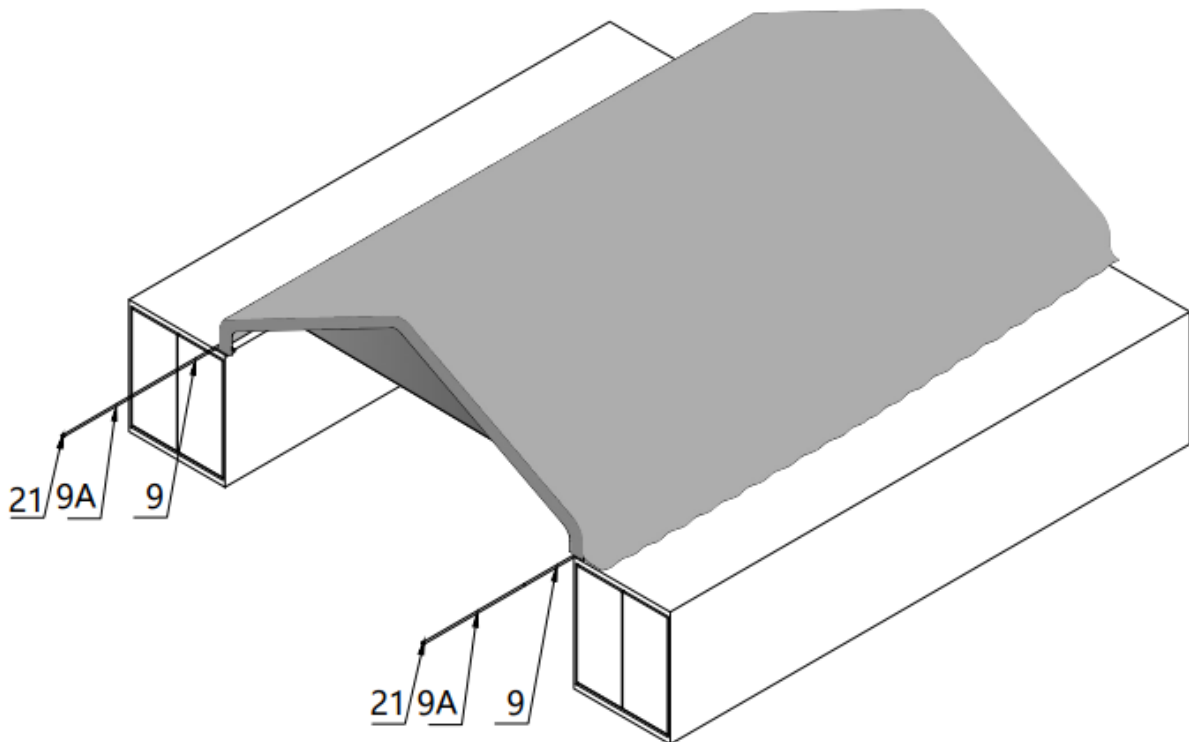
- Insert tension tubes (#9) slowly into the bottom groove pocket on both long sides. Add the water plug (#21) on the first tension tube to avoid tearing the fabric and add one to the end of last tube as well.
- Repeat the same step for the other side.

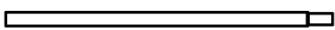
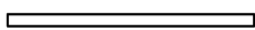



NO.	Part	Qty
9		12
9A		2
21		4

Step 11 : Install ratchet straps.

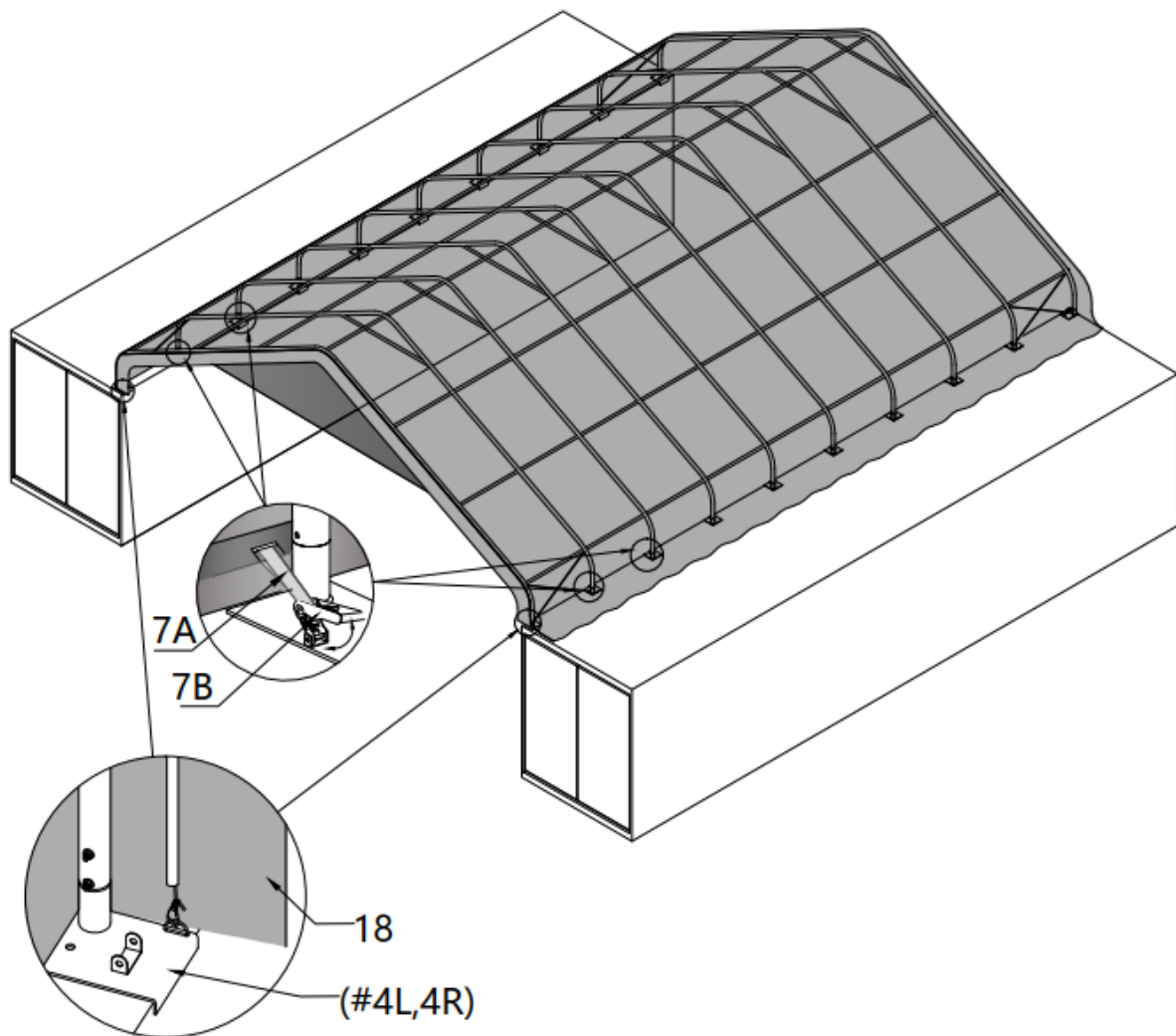
- Stretch and adjust the cover from left and right, back and forth, to make sure it is square and centered. Cut the groove pocket where it aligns with ratchet (#7A), and use strap (#7B) to pull tension tube (#9) to ward the ratchet and secure it.
- Evenly adjust all ratchets on both sides to take wrinkles out and make the cover flat and smooth.



NO.	Part	Qty
7A		20
7B		20

After Installation

Walk around and inspect the building periodically to make sure the parts are firmly fixed and the whole building is well supported. Check all bolts and hardware connectors to make sure they are in place and tightened. Check the base plates, adjust the ropes if necessary and clean the cover regularly.

Snow accumulating on the fabric cover must be removed as soon as possible. If snow is allowed to become solid ice on the cover, it could increase the weight on the roof and collapse the building or reduce the life span.

We strongly recommend you remove any snow from the roof immediately. Do not leave any snow load on the roof overnight. Keep 3 feet of clearance on all sides at all times. Do not allow snow to accumulate and pile up on the sides of the building. Otherwise the pressure from the sides will push inwards and could lead to a collapse.