

### MODEL TMG-ST2021CE

# 20' X 20' SINGLE TRUSS STORAGE CONTAINER SHELTER

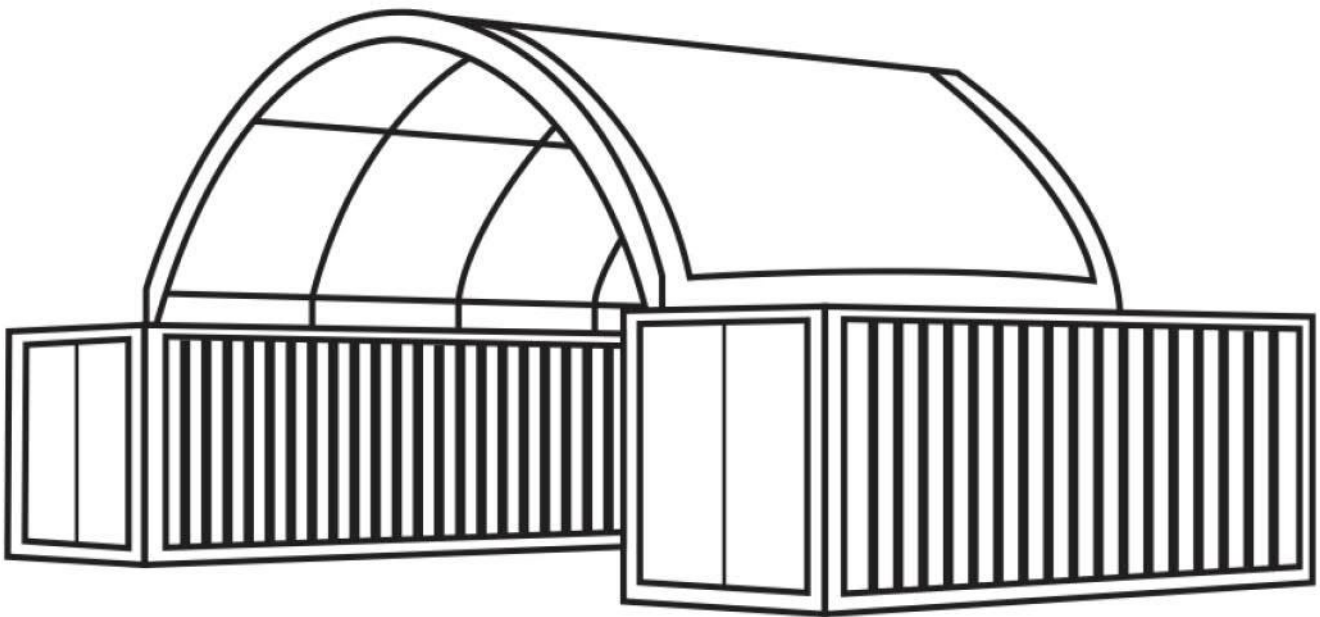

- Please read and understand the product manual completely before assembly
- Check against the parts list to make sure all parts are received
- Wear proper safety goggles or other protective gears while in assembly
- Do not return the product to dealer. They are not equipped to handle your requests.

Missing parts or have questions on assembly?  
Please call: 1-877-761-2819 or email: [cs@tmgindustrial.com](mailto:cs@tmgindustrial.com)

## **Main Specifications :**

- Overall assembled size : W6 x L6 x H2 (m) / 19.68 x 19.68 x 6.5(ft)
- Ridge Peak Height : 2 m / 6.5ft + container height

## **Prior to assembly**

Please read the instructions carefully before installation. It is very important to follow your local safety regulations and industry standards during installation. Regulations may include but are not limited to:

- Safety helmets, protective eyewear, and clothing
- Safety harnesses for all elevated workers
- Proper ladder, cage, and safety operation

Check all components and parts before installation. All parts are marked with a part number, please refer to the parts list to make sure you have all parts.









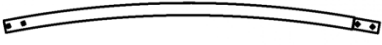

Choose a day with low or no wind to install, assembly is hard in heavy wind. Do not make any alterations to the structure. Do not hang any weights on the frame during installation, including parts. We are not responsible for any damages or injuries caused by inappropriate installation, unauthorized modifications or extreme weather.

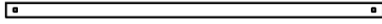
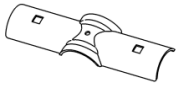

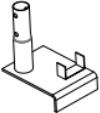
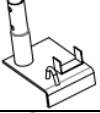
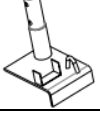

This building is not intended for human occupancy.

It is recommended to use heavy duty duct tapes to tape the tube connection joint spots to protect the cover from damage and worn. It will help to extend the cover life span.

Check the parts list below to make sure all parts are received prior to assembly.

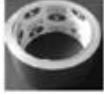
### TMG-ST2021CE Part List

Parts code	Graphical	Description	length	Qty
1		Dome arch pipe	φ48xL2192mm	6
2		Middle rafter tube	φ48xL1481mm	12
3		Shoulder tube	φ48xL1428mm	12
4		Roof purlin (horizontal tube)	φ42xL1148mm	25
4A		Middle truss connectors	W50xL170mm	40
4B		Front and rear connectors	W50xL111mm	10
5		Middle truss baseplate	W150xL200mm	8
5L		Left corner baseplate (front and rear truss)	W150xL200mm	2
5R		Right corner baseplate (front and rear truss)	W150xL200mm	2
6		Top cover tension tube A	φ32xL2093mm	4
6A		Top cover tension tube B	φ32xL2030mm	2
12		Top cover	W6.74xL8.520m	1
13		Ratchet	2T	12
13A		Tie down straps	W30xL800mm	12
14		Braided rope	φ8x60m	1 bundle

15		Scratch resistant tape	φ25mm	1
16		Half round head bolt	M10x80mm	50
17		Hex bolt	M10x70mm	72
18		Water plug	φ32mm	4
20		Self tapping screw	φ12x25mm	30

**Step 1 : Baseplate positioning and installation.**

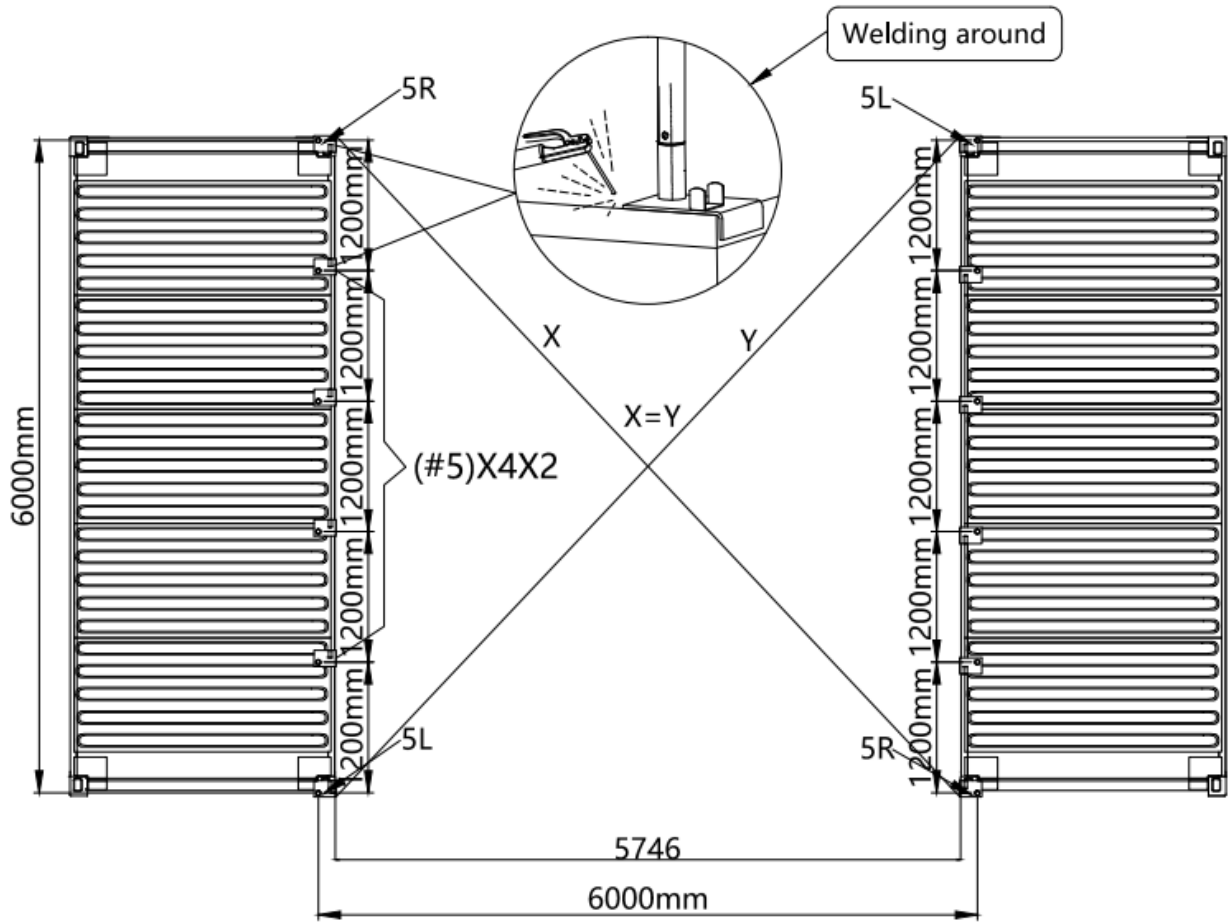

1

Parts code	Graphical	Qty
5		8
5L		2
5R		2

**Step 2 : Install 6 sets of trusses.**

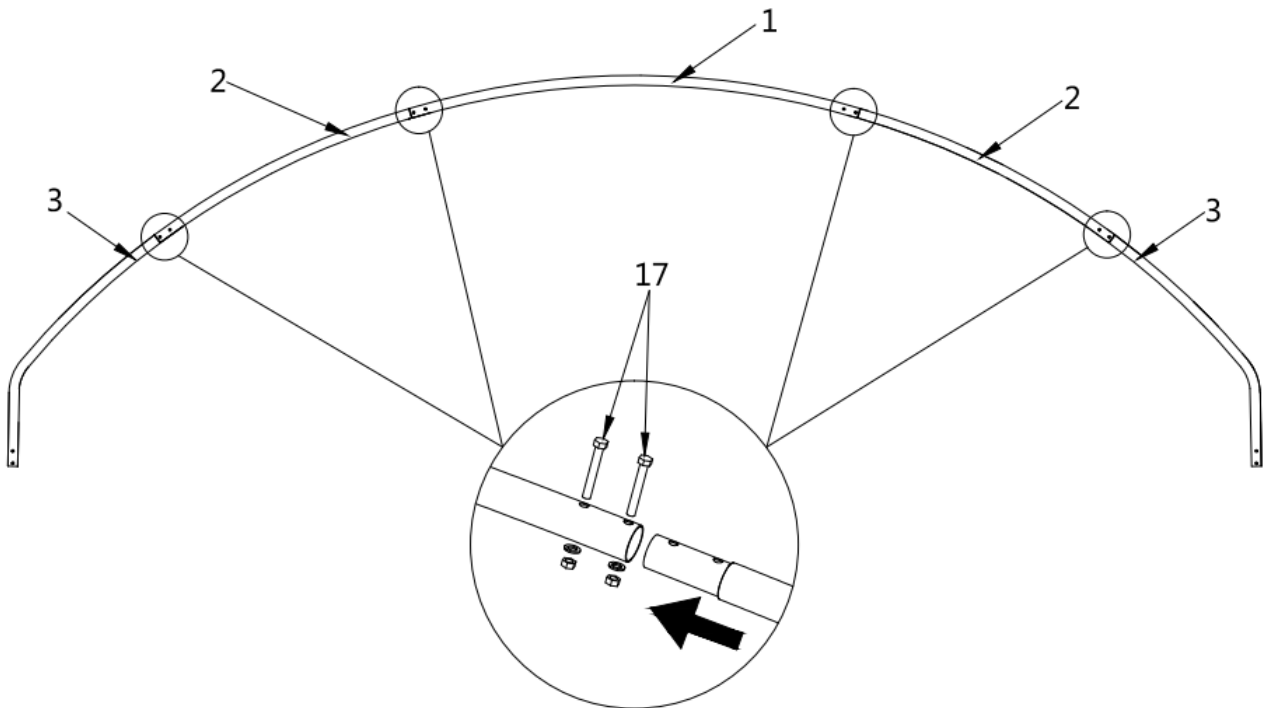

Parts code	Graphical	Qty
1		1x6
2		2x6
3		2x6
17		8x6

**Step 3 : Wrap (#15) around the sharp points of the joint to avoid friction between the fabric and the interface.**

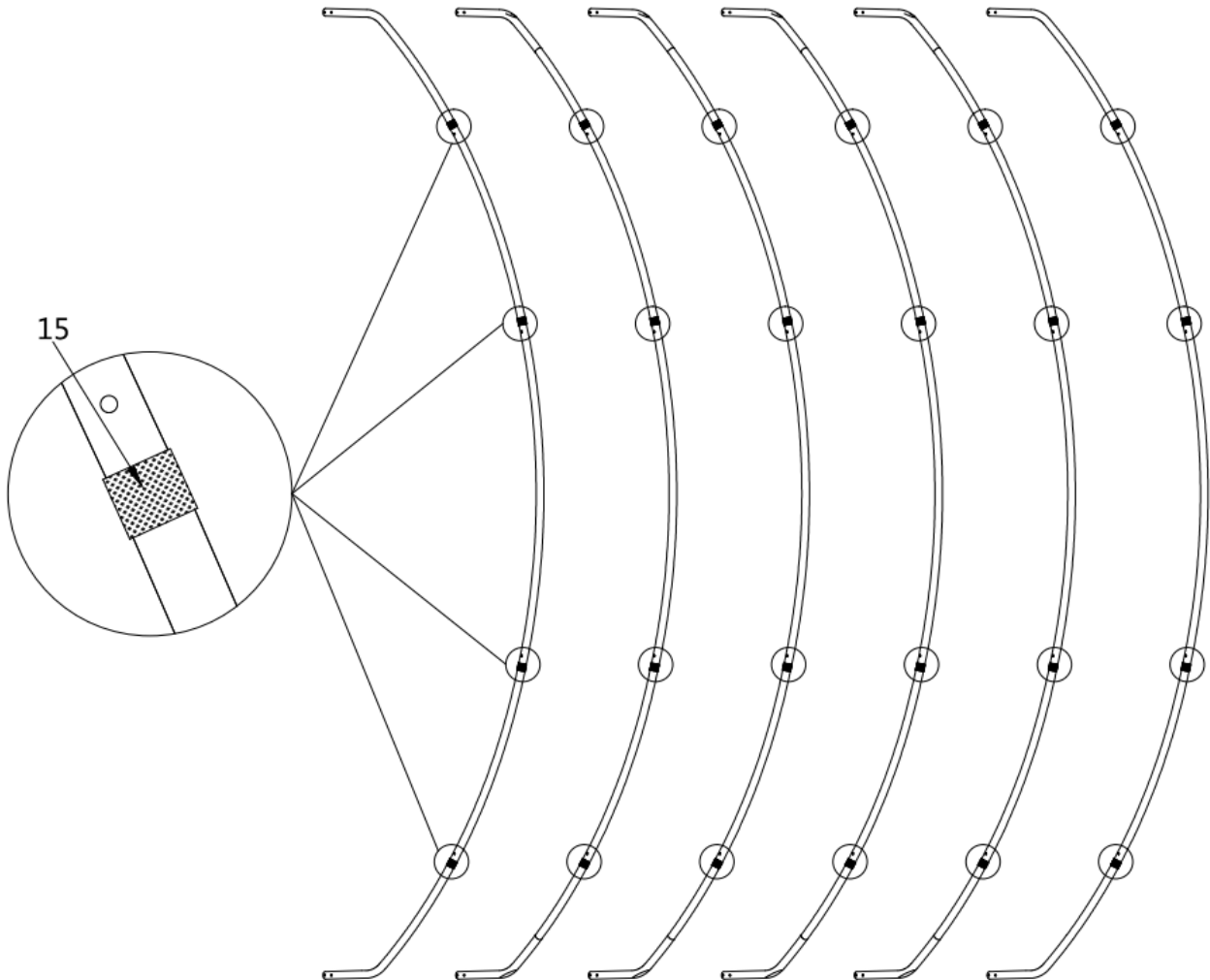

Parts code	Graphical	Qty
15		1

**Step 4 : Put up all trusses.**

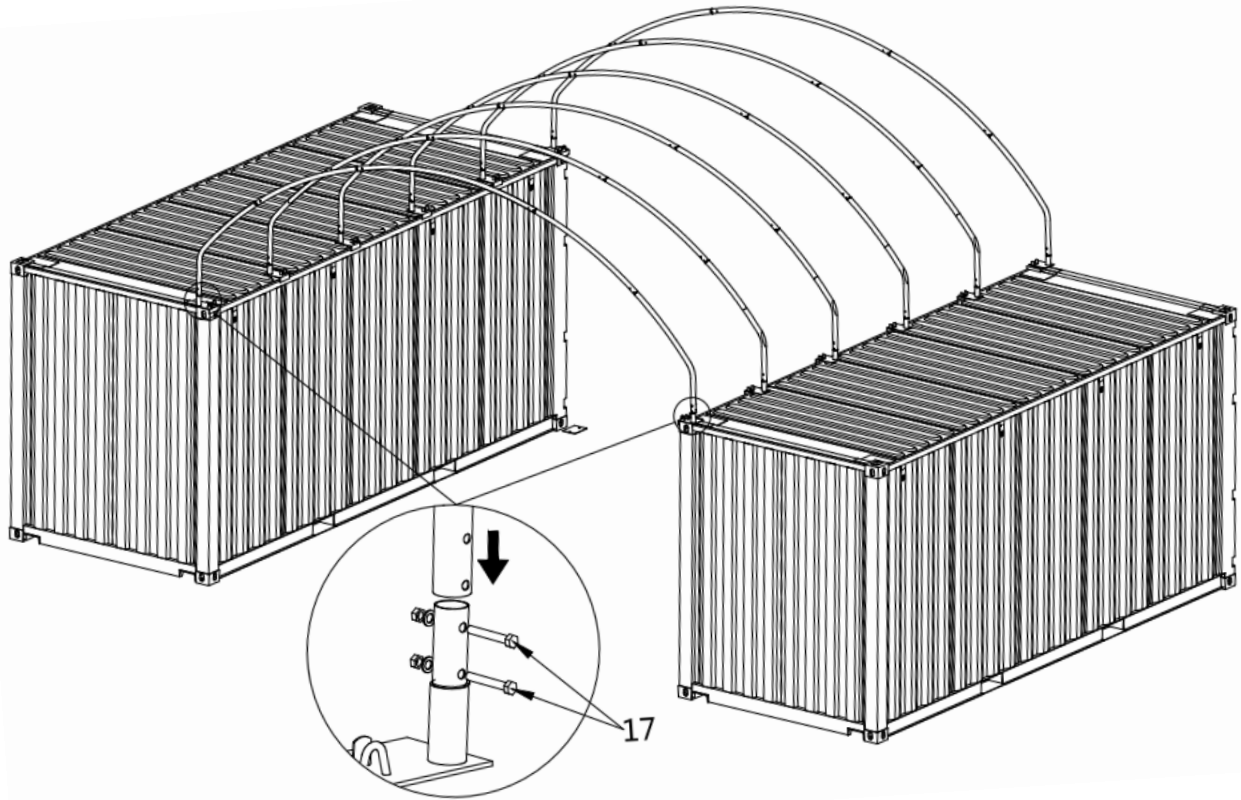

<b>Parts code</b>	<b>Graphical</b>	<b>Qty</b>
17		24



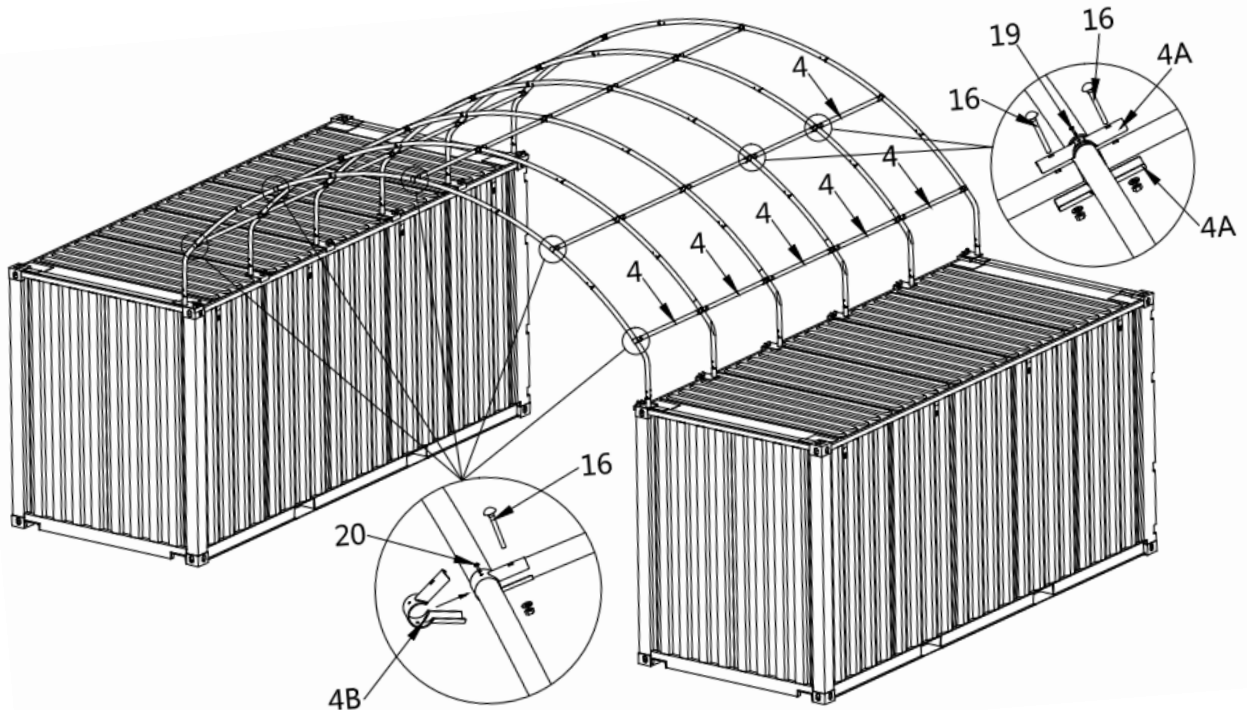

**Step 5 : Installation of roof purlin.**



Parts code	Graphical	Qty
4		25
4A		40
4B		10
16		50
19		30

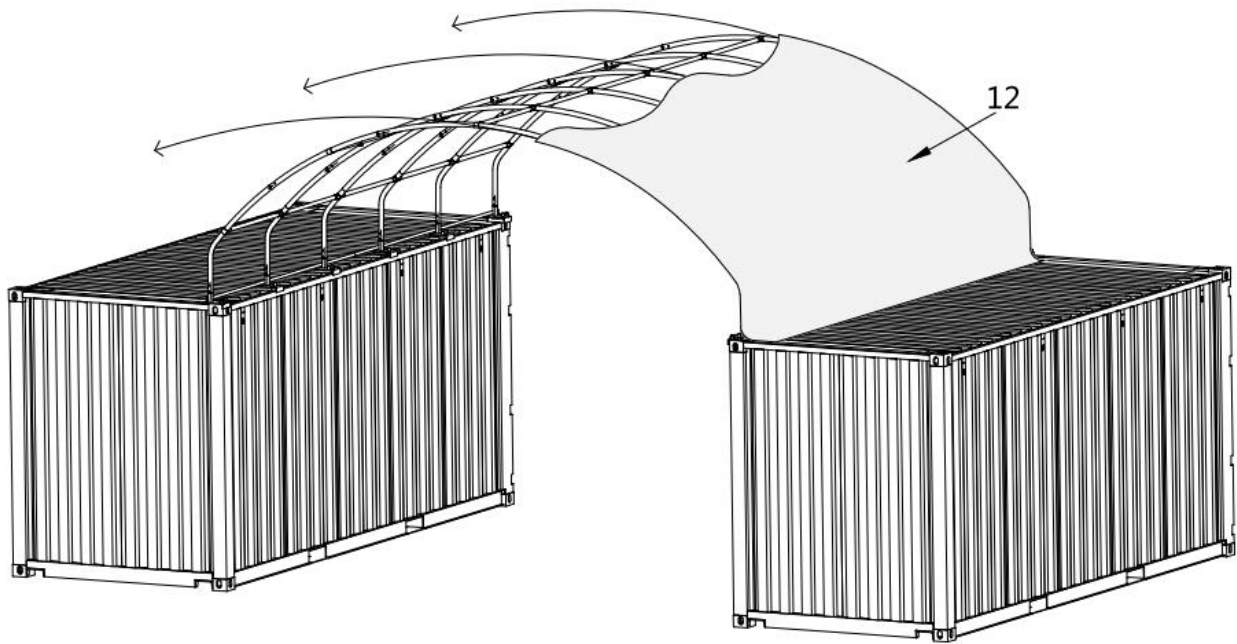

**Step 6 : Install the cover.**



<b>Parts code</b>	<b>Graphical</b>	<b>Qty</b>
12		1

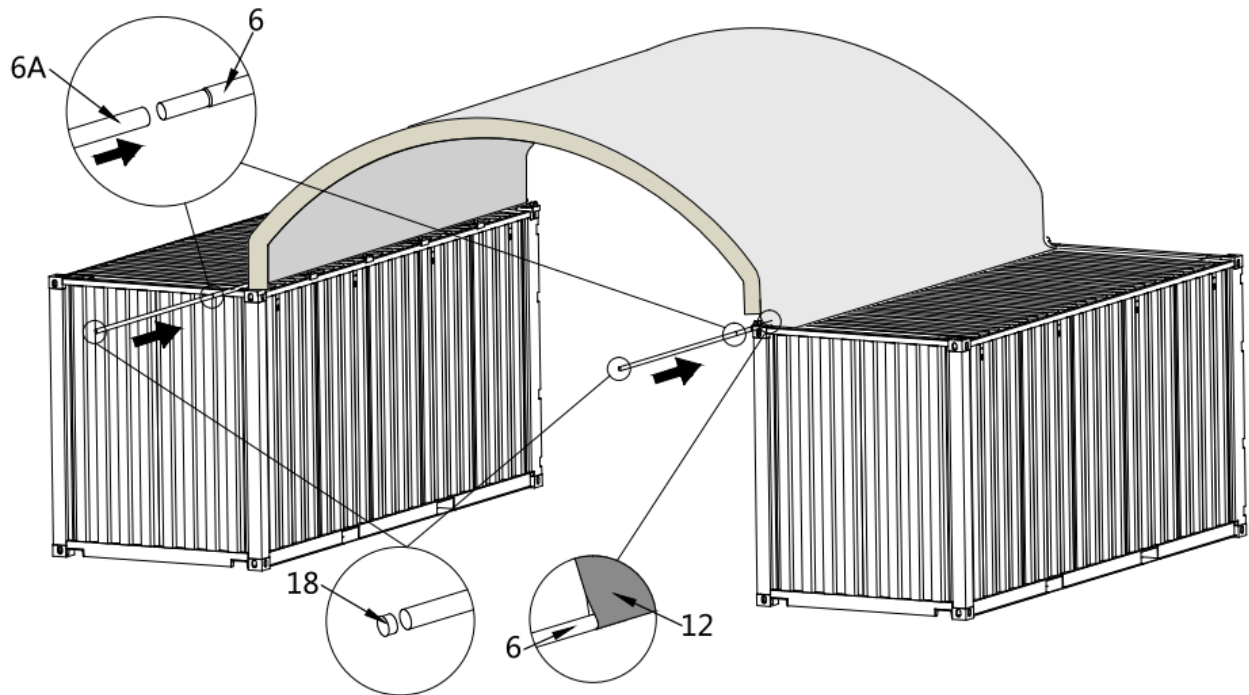

**Step 7 : Install metal pipes on both sides.**

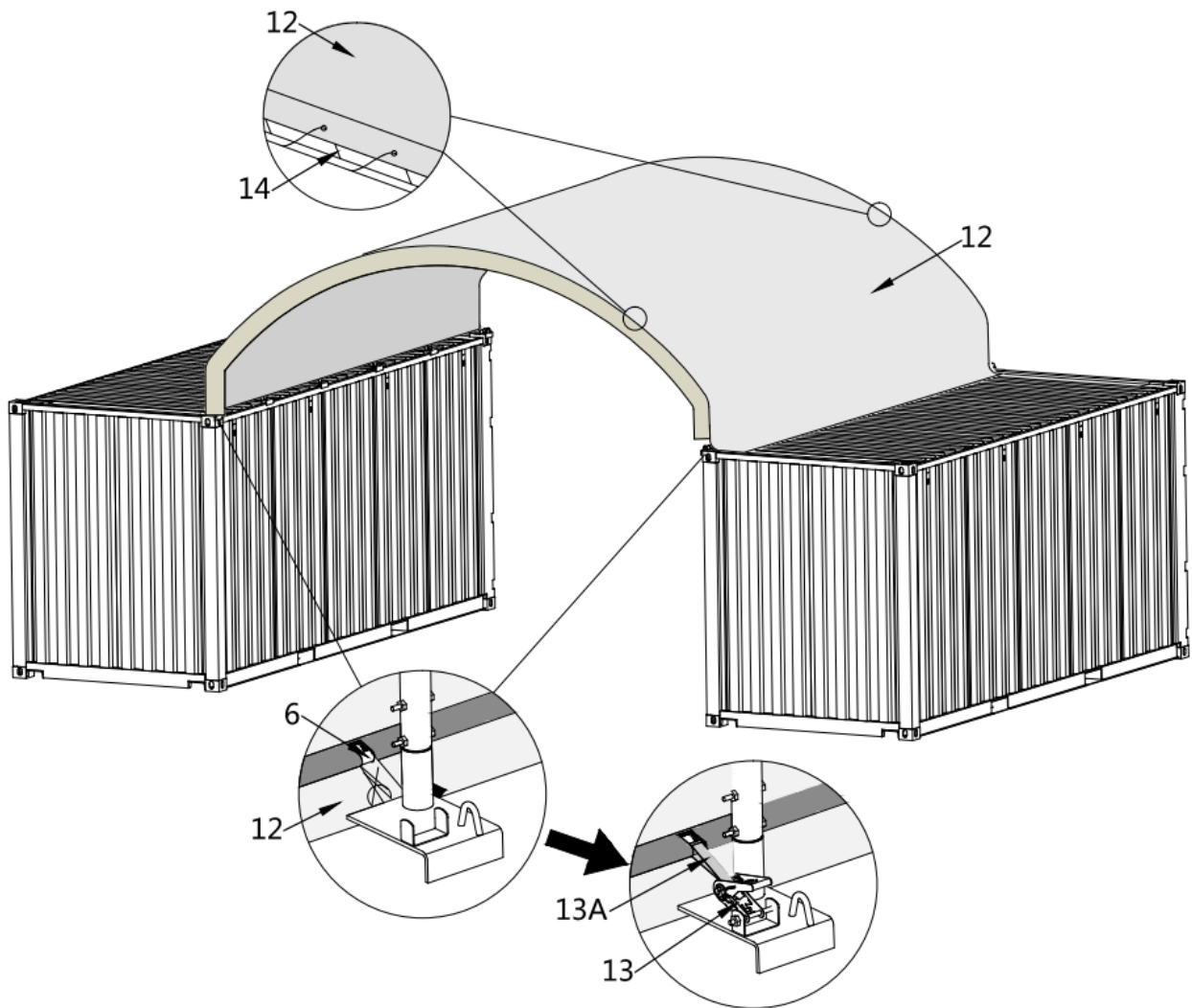

Parts code	Graphical	Qty
6		4
6A		2
18		4

**Step 8 : Tension the top cloth with tensioning device and braided rope.**



Parts code	Graphical	Qty
13		12
13A		12
14		1 bundle

## **After Installation**

Walk around and inspect the building periodically to make sure the parts are firmly fixed and the whole building is well supported. Check all bolts and hardware connectors to make sure they are in place and tightened. Check the base plates, adjust the ropes if necessary and clean the cover regularly.

Snow accumulating on the fabric cover must be removed as soon as possible. If snow is allowed to become solid ice on the cover, it could increase the weight on the roof and collapse the building or reduce the life span.

We strongly recommend you remove any snow from the roof immediately. Do not leave any snow load on the roof overnight. Keep 3 feet of clearance on all sides at all times. Do not allow snow to accumulate and pile up on the sides of the building. Otherwise the pressure from the sides will push inwards and could lead to a collapse.