

MODEL TMG-RT165/RT185**3-Point Rotary Tiller****⚠ WARNING**

- Please read and understand the product manual completely before assembly
- Check against the parts list to make sure all parts are received
- Wear proper safety goggles or other protective gears while in assembly
- Do not return the product to dealer. They are not equipped to handle your requests.

Missing parts or have questions on assembly?

Please call: 1-877-761-2819 or email: cs@tmgindustrial.com

Important Safety Information	2
Safety at All Times	2
Look For The Safety Alert Symbol	2
Safety Labels	5
Introduction	7
Application	7
Terminology	7
Owner Assistance	7
Serial Number Plate	7
Section 1: Assembly and Set-up	8
Tractor Requirements	8
Assembly	8
Tractor Hook-Up	9
Driveline Hook-Up	9
Section 2: Operating Instructions	9
Safety Information	9
General Operating Notes	11
General Operating Instructions	11
Skid Shoe Adjustment	11
Section 3: Maintenance and Lubrication	12
Maintenance	12
Tine Replacement	11
Long-Term Storage	12
Lubrication	13
Section 4: Troubleshooting	14
Section 5: Appendix	15
Section 6: Part List	16



Important Safety Information

Safety at All Times

Careful operation is your best assurance against an accident. All operators, no matter how much experience they may have, should carefully read this manual and other related manuals, or have the manuals read to them, before operating the power machine and this implement.

- Thoroughly read and understand the “Safety Label” section. Read all instructions noted on them.
- Do not operate the equipment while under the influence of drugs or alcohol as they impair the ability to safely and properly operate the equipment.
- The operator should be familiar with all functions of the tractor and attached implement, and be able to handle emergencies quickly.
- Make sure all guards and shields appropriate for the operation are in place and secured before operating the implement.
- Keep all bystanders away from equipment and work area.
- Start tractor from the driver’s seat with hydraulic controls in neutral.
- Operate tractor and controls from the driver’s seat only.
- Never dismount from a moving tractor or leave tractor unattended with engine running.
- Do not allow anyone to stand between tractor and implement while backing up to implement.
- Keep hands, feet, and clothing away from power-driven parts.
- While transporting and operating equipment, watch out for objects overhead and along side such as fences, trees, buildings, wires, etc.
- Do not turn tractor so tight as to cause hitched implement to ride up on the tractor’s rear wheel.
- Store implement in a safe and secure area where children normally do not play. When needed, secure implement against falling with support blocks.

Look for the Safety Alert Symbol

The SAFETY ALERT SYMBOL indicates there is a potential hazard to personal safety and extra precaution must be taken. When you see this symbol, be alert and carefully read the message that follows it. Hazard control, and accident prevention are dependent upon the awareness, concern, prudence, and proper training of personnel involved in the operation, transport, maintenance, and storage of equipment.

Be Aware of Signal Words

A signal word designates a degree or level of hazard seriousness. They are:



DANGER: Indicates a hazardous situation that, if not avoided, will result in death or serious injury.



WARNING: Indicates a hazardous situation that, if not avoided, could result in death or serious injury.



CAUTION: Indicates a hazardous situation that, if not avoided, may result in minor or moderate injury.

Be Aware of Special Notices

Special notices are intended to point out important and helpful information that should be followed. They are usually placed inside a box. They are:

IMPORTANT: Indicates that equipment or property damage could result if instructions are not followed.

NOTES: Indicates supplementary explanations that will be helpful when using the equipment.

Safety Precautions for Children

Tragedy can occur if the operator is not alert to the presence of children, Children generally are attracted to implements and their work.

- Never assume children will remain where you last saw them.
- Keep children out of the work area and under the watchful eye of a responsible adult.
- Be alert and shut the implement and tractor down if children enter the work area.
- Never carry children on the tractor or implement. There is not a safe place for them to ride. They may fall off and be run

over or interfere with the control of the power machine.

- Never allow children to operate the power machine, even under adult supervision.
- Never allow children to play on the power machine or implement.
- Use extra caution when backing up. Before the tractor starts to move, look down and behind to make sure the area is clear.

Tractor Shutdown & Storage

- If engaged, disengage power take-off.
- Park on solid, level ground and lower implement to ground or onto support blocks.
- Put tractor in park or set park brake.
- Turn off engine and remove ignition key to prevent unauthorized starting.
- Relieve all hydraulic pressure to auxiliary hydraulic lines.
- Wait for all components to stop before leaving operator's seat.
- Use steps, grab-handles and anti-slip surfaces when stepping on and off the tractor.

Listed below are common practices that may or may not be applicable to the products described in this manual.

Transport Safely

- Comply with federal, state, and local laws.
- Use towing vehicle and trailer of adequate size and capacity. Secure equipment towed on a trailer with tie downs and chains.
- Sudden braking can cause a towed trailer to swerve unexpectedly. Reduce speed if towed trailer is not equipped with brakes.
- Avoid contact with any overhead utility lines or electrically charged conductors.
- Always drive with load on end of loader arms low to the ground.
- Always drive straight up and down steep inclines with heavy end of skid steer on the "uphill" side.
- Engage park brake when stopped on an incline.
- Maximum transport speed for an attached equipment is 20 mph (32 km/h). **DO NOT EXCEED.** Never travel at a speed which does not allow adequate control of steering and stopping. Some rough terrains require a slower speed.
- As a guideline, use the following maximum speed weight ratios for attached equipment:

20 mph (32 km/h) when weight of attached equipment is less than or equal to the weight of machine towing the equipment.

10 mph (16 km/h) when weight of attached equipment exceeds weight of machine towing equipment but not more than double the weight.

- **IMPORTANT:** Do not tow a load that is more than double the weight of the vehicle towing the load.

Practice Safe Maintenance

- Understand procedure before doing work. Refer to the Operator's Manual for additional information.
- Work on a level surface in a clean dry area that is well-lit.
- Lower implement to the ground and follow all shutdown procedures before leaving the operator's seat to perform maintenance.
- Do not work under any hydraulically supported equipment. It can settle, suddenly leak down, or be lowered accidentally. If it is necessary to work under the equipment, securely support it with stands or suitable blocking beforehand.
- Use properly grounded electrical outlets and tools.
- Use correct tools and equipment for the job that are in good condition.
- Allow equipment to cool before working on it.
- Disconnect battery ground cable (-) before servicing or adjusting electrical systems or before welding on implement. ⚠ Inspect all parts. Make certain parts are in good condition & installed properly.
- Replace parts on this implement with genuine Land Pride parts only. Do not alter this implement in a way which will



adversely affect its performance.

- Do not grease or oil implement while it is in operation. ○ Remove buildup of grease, oil, or debris.
- Always make sure any material and waste products from the repair and maintenance of the implement are properly collected and disposed.
- Remove all tools and unused parts from equipment before operation.
- Do not weld or torch on galvanized metal as it will release toxic fumes.

Prepare for Emergencies

- Be prepared if a fire starts.
- Keep a first aid kit and fire extinguisher handy.
- Keep emergency numbers for doctor, ambulance, hospital, and fire department near the phone.

Wear Personal Protective Equipment (PPE)

- Wear protective clothing and equipment appropriate for the job such as safety shoes, safety glasses, hard hat, dust mask, and ear plugs.
- Clothing should fit snug without fringes and pull strings to avoid entanglement with moving parts.
- Prolonged exposure to loud noise can cause hearing impairment or hearing loss. Wear suitable hearing protection such as earmuffs or earplugs.
- Operating a machine safely requires the operator's full attention. Avoid wearing headphones while operating equipment.

Avoid High Pressure Fluids

- Escaping fluid under pressure will penetrate the skin or eyes causing serious injury.
- Relieve all residual pressure before disconnecting hydraulic lines or performing work on the hydraulic system.
- Make sure all hydraulic fluid connections are properly tightened/torqued and all hydraulic hoses and lines are in good condition before applying pressure to the system.
- Use a piece of paper or cardboard, NOT BODY PARTS, to check for suspected leaks.
- Wear protective gloves and safety glasses or goggles when working with hydraulic systems.
- DO NOT DELAY. If an accident occurs, seek immediate emergency medical care or gangrene may result.

Use Safety Lights and Devices

- A Slow moving power machine can create a hazard when driven on public roads. They are difficult to see, especially at night. Use the Slow Moving Vehicle (SMV) sign when on public roads.
- Flashing warning lights and turn signals are recommended whenever driving on public roads.

Use Seat Belt and ROPS

- TMG recommends the use of a CAB or roll-over-protective-structures (ROPS) and seat belt in almost all power machines. Combination of a CAB or ROPS and seat belt will reduce the risk of serious injury or death if the power machine should be upset.
- If ROPS is in the locked-up position, fasten seat belt snugly and securely to help protect against serious injury or death from falling and machine overturn.

Keep Riders Off Machinery

- Never carry riders on the tractor or implement.
- Riders obstruct operator's view and interfere with the control of the power machine.
- Riders can be struck by objects or thrown from the equipment.
- Never use the tractor or implement to lift or transport riders.



Avoid crystalline Silica (quartz) Dust

Because crystalline silica is a basic component of sand and granite, many activities at construction sites produce dust containing crystalline silica. Trenching, sawing, and boring of material containing crystalline silica can produce dust containing crystalline silica particles. This dust can cause serious injury to the lungs (silicosis).

There are guidelines which should be followed if crystalline silica (quartz) is present in the dust.

- Be aware of and follow OSHA (or other local, State, or Federal) guidelines for exposure to airborne crystalline silica.
- Know the work operations where exposure to crystalline silica may occur.
- Participate in air monitoring or training programs offered by the employer.
- Be aware of and use optional equipment controls such as water sprays, local exhaust ventilation, and enclosed cabs with positive pressure air conditioning if the machine has such equipment. Otherwise respirators shall be worn.
- Where respirators are required, wear a respirator approved for protection against crystalline silica containing dust. Do not alter respirator in any way. Workers who use tight-fitting respirators can not have beards/mustaches which interfere with the respirator seal to the face.
- If possible, change into disposable or washable work clothes at the work site; shower and change into clean clothing before leaving the work site.
- Do not eat, drink, use tobacco products, or apply cosmetics in areas where there is dust containing crystalline silica.
- Store food, drink, and personal belongings away from the work area.
- Wash hands and face before eating, drinking, smoking, or applying cosmetics after leaving the exposure area.

Handle Chemicals Properly

- Protective clothing should be worn.
- Handle all chemicals with care.
- Follow instructions on container label.
- Agricultural chemicals can be dangerous. Improper use can seriously injure persons, animals, plants, soil, and property.
- Inhaling smoke from any type of chemical fire can be a serious health hazard.
- Store or dispose of unused chemicals as specified by the chemical manufacturer.

Safety Labels

Your Rotary Tiller comes equipped with all safety labels in place. They were designed to help you safely operate your equipment. Read and follow their directions.

1. Keep all safety labels clean and legible.
2. Refer to this section for proper label placement. Replace all damaged or missing labels.
3. Some new equipment installed during repair requires safety labels to be affixed to the replaced component as specified by TMG. When ordering new components make sure the correct safety labels are included in the request.
4. Refer to this section for proper label placement. To install new labels:
 - a. Clean surface area where label is to be placed.
 - b. Spray soapy water onto the cleaned area.
 - c. Peel backing from label and press label firmly onto the surface.
 - d. Squeeze out air bubbles with edge of a credit card or with a similar type of straight edge.





Introduction

TMG welcomes you to the growing family of new product owners. This implement has been designed with care and built by skilled workers using quality materials. Proper assembly, maintenance, and safeoperating practices will help you get years of satisfactory use from the rotary tiller.

Application

The rotary tillers are designed and built to till soil for seedbed and planting preparation with uses in both rural and non-rural applications such as gardening and landscaping. They are designed for 30-60hp tractors with Category I & II three point hitch mounting, 540 rpm power take-off speed.

Terminology

“Right” or “Left” as used in this manual is determined by facing the direction the machine will operate while in use unless otherwise stated.

Owner Assistance

The Warranty Registration card should be filled out by the dealer at the time of purchase. This information is necessary to provide you with quality customer service. If customer service or repair parts are required contact a dealer. A dealer has trained personnel, repair parts and equipment needed to service the machine. The parts on your machine have been specially designed and should only be replaced with genuine parts.

Serial Number Plate

For prompt service always use the serial number and model number when ordering parts from your dealer. Be sure to include your serial and model numbers in correspondence also.



Section 1: Assembly and Set-up

Tractor Requirements

Tractor horsepower should be within the range noted below. Tractors outside the horsepower range must not be used.

Hitch Category-----3-Point Cat. I & II

Power Take-Off Speed-----540 rpm

Horsepower Requirements-----30-60 hp

Assembly

1. Remove all loose parts or packaging from the crate, check goods without damaged and omission.
2. Check the packing list as below,

Part No.	Ref. No.	Parts Description	Qty
1	1GR185.01	Frame and Rotor Assembly	1
2	GB/T5872-2000	Bolt-M12x40	8
3	1GR185.01.013	Hitch	1
4	1G135.02.117	Guard shade	1
5	T5S-YS-07-07*750	PTO drive shaft	1

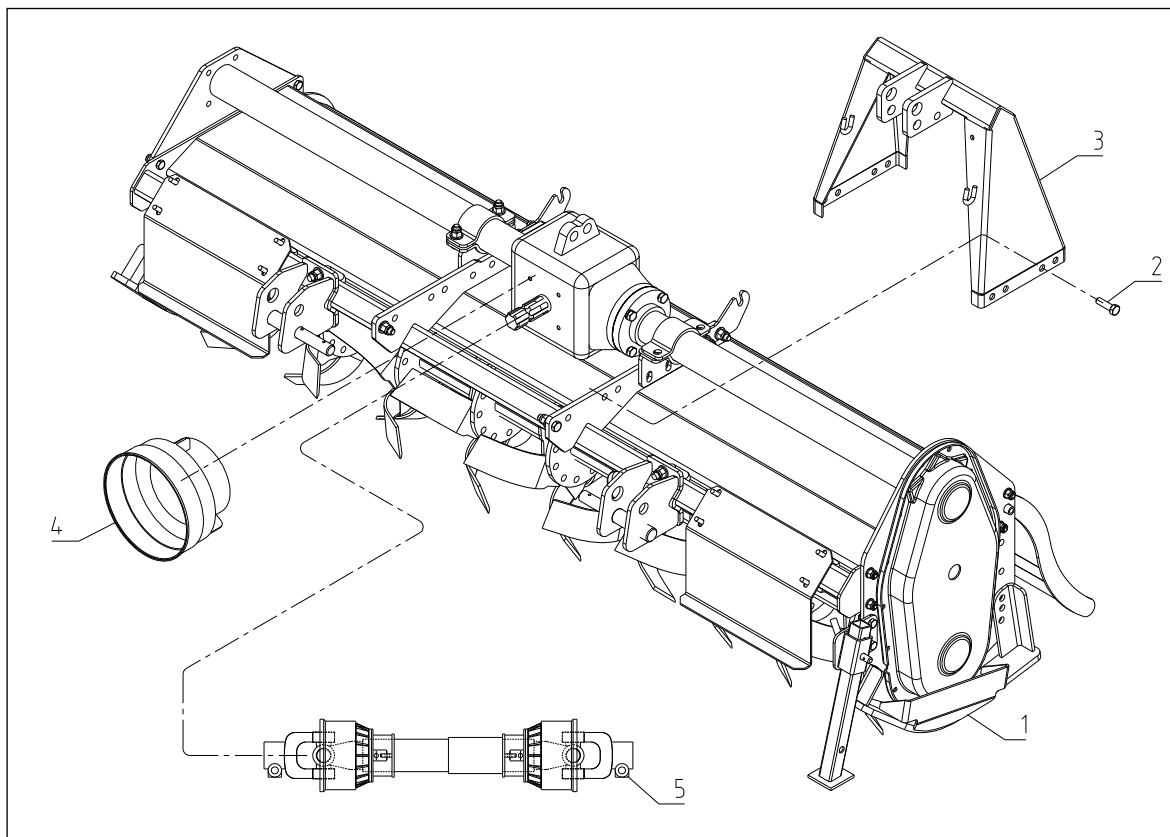

3. Assemble the part 4 (guard shade) to gearbox, assemble the part 3 (hitch) to the part 1 (frame and rotor assembly), you will get the rotary tiller assembled.

Tractor Hook-Up

IMPORTANT: The tractor's lower 3-point arms must be stabilized to prevent side-to-side movement. Most tractors have sway blocks or adjustable chains for this purpose.

IMPORTANT: To prevent damaging the park stand, always store the stand in its transport position before moving the tiller.

1. Make sure you have read and follow all safety alerts, Important Notes, and Notes before continuing.
2. The tiller is equipped with a Cat. I & II hitch. Make sure your tractor's hitch is compatible with the tiller's hitch.
3. Remove lower linchpins and hitch pins .
4. Customer to supply upper hitch pin and hitch pin keeper. If installed, remove customer supplied hitch pin and hitch pin keeper.
5. Slowly back tractor to tiller while using tractor's 3-point control lever to align holes in lower 3-point lift arms with holes in clevises.
6. Put tractor gear selector in park or set park brake, shut off tractor engine, and remove switch key before dismounting tractor.
7. Attach lower 3-point lift arms to clevises with hitch pins. Secure hitch pins with linchpins.
8. Attach tractor's top center 3-point link to tiller hitch plates with customer supplied hitch pin and hitch pin keeper.
9. With gear selector in park or tractor park brake set, start tractor and raise tiller off the ground several inches. Shut tractor off and remove switch key.
10. Move park stand to transport position.
11. Adjust tractor's top center link to level tiller from front to back. A level placed on top back half of the right hand side plate can be used to check for levelness.
12. Adjust one of the two tractor's lower 3-point lift arms up or down to level tiller from left to right. A level placed on the square tube can be used to check for levelness.
13. Raise tiller fully up with 3-point lift arms. Measure distance the tines are off the ground. If distance exceeds 14" (36 cm), adjust tractor's 3-point lift height limiter until tines will not lift higher than 14" (36 cm) off the ground.
14. Continue with "Driveline Hook-Up".

Driveline Hook-up

IMPORTANT: The drivelines must be lubricated before putting them into service

IMPORTANT: Drivelines with friction clutches must go through a "run-in" prior to initial use and after long periods of inactivity.

IMPORTANT: The power take-off shaft and gearbox input shaft must be aligned and level with each other when checking driveline minimum length. A driveline that is too long can damage tractor and implement.

1. Park tractor and tiller on a level surface.
2. Shut tractor down before dismounting.
3. If tractor drawbar interferes with the driveline during hook-up, disconnect driveline and move drawbar forward, to the side, or remove.
4. Push in on driveline yoke pin (#13) and push yoke onto the tractor power take-off shaft. Release push pin and continue to push driveline yoke forward until push pin pops out and yoke collar locks in place.
5. Pull on driveline yoke at the tractor to make sure it is secured to the tractor power take-off shaft.

Section 2: Operating Instructions

Safety Information

DANGER To avoid serious injury or death:

- Do not engage power take-off while hooking-up or unhooking the driveline, or while someone is standing near the driveline. A person's body and/or clothing can become entangled in the driveline.
- Keep away from rotating hex drive shaft located between gearbox and drive end of tiller. A person can become entangled in the shaft.
- Keep front rubber dirt deflector on reverse tine tillers in place while operating the unit. Objects in a reverse tine tiller can be thrown forward toward the operator.

- Keep yourself and all others away from rotating tines and drive train. Always disengage power take-off and lockout power source before making adjustments or servicing the tiller. A person's body, hair, or clothing can become entangled in rotating components causing serious bodily injury or death.
- Make all 3-point hydraulic adjustments from the tractor seat. Never make hydraulic adjustments while standing behind the tractor.
- Tractor power take-off shaft shield, driveline shields, and gearbox shaft shields must be installed and in good working condition to avoid driveline entanglement and projectiles flying off of the driveline.
- Tine impact on objects can throw projectiles resulting in bodily injury or death. Do not point discharge toward people, animals, or buildings and keep people and animals away from tiller during operation.
- Do not use a power take-off adapter. The adapter will increase strain on the tractor's power take-off shaft causing possible damage to shaft and driveline. It will also defeat the purpose of the tractor's power take-off shield.
- Make certain driveline yokes are securely fastened at each end. A loose yoke can work free allowing the driveline to rotate uncontrollably.

WARNING To avoid serious injury or death:

- Allow only persons to operate this implement who have fully read and comprehended this manual, and who have been properly trained in the safe operation of this implement. Serious injury or death can result from the inability to read, understand, and follow instructions provided in this manual.
- Never carry riders on the implement or tractor. Riders can obstruct the operator's view, interfere with controls, be pinched by moving components, become entangled in rotating components, struck by objects, thrown about, fall off and be run over, etc.
- Do not till across steep inclines that are subject to rollover. The action of the tines being forced down into the ground can cause the tractor to roll-over resulting in serious injury or death. Consult your tractor's manual for acceptable inclines the tractor is capable of traveling across.
- Check driveline when lowering tiller into the ground to make sure it does not interfere with the tractor drawbar at maximum depth. If needed, shut tractor off and move or remove drawbar to prevent damage to the driveline.
- Always disengage power take-off immediately after lifting tiller above ground level. Never operate tiller in the raised position. The tiller can discharge objects at high speeds resulting in injury or death.
- Be careful when working areas where obstructions can be hidden. Always mark potential hazards with a visible flag. Travel slowly through high risk areas and be prepared to stop immediately should implement make contact with a solid object.
- Do not use implement as a man lift or work platform. It is not properly designed or guarded for this use.
- Perform scheduled maintenance. Check for loose hardware, missing parts, broken parts, structural cracks, and excessive wear. Make repairs before putting the implement back into service.
- Do not use implement to lift objects; to pull objects such as fence posts, stumps, etc; or to push objects. The unit is not designed or guarded for these uses.
- Do not use implement to tow other equipment unless it is designed with a tow hitch. Doing so can result in loss of control and damage the equipment.
- Do not alter implement or replace parts on the implement with other brands. Other brands may not fit properly or meet OEM (Original Equipment Manufacturer) specifications. They can weaken the integrity and impair the safety, function, performance, and life of the implement. Replace parts only with genuine OEM parts.
- Do not use implement for a purpose other than the work it is designed to do as defined in this manual.
- Do not operate a broken or bent driveline. Such a driveline will break apart while rotating at high speeds. Always remove the implement from use until the damaged driveline can be repaired or replaced.
- Avoid exposure to dust containing crystalline silica particles. This dust can cause serious injury to the lungs(silicosis). Because crystalline silica is a basic component of sand and granite, many activities at construction sites produce dust containing crystalline silica. Trenching, sawing, and boring of material containing crystalline silica can produce dust containing crystalline silica.
- Some tractors are equipped with two power take-off speeds. Be certain your tractor's power take-off shaft is set-up to operate at 540 rpm. Do not exceed 540 rpm power take-off speed. Excessive speed can damage drive components, cutter blades, and/or increase risk of throwing an object.



General Operating Notes

Before operating the tiller, the following inspection should be performed:

1. Check oil level in gearbox and chain case.
2. Check that all plugs have been replaced properly in the gearbox and chain case.
3. Be sure all tiller tines, bolts, and nuts are tight.
4. Be certain all guards, shields, tailgate, and front dirt deflector are in place and secure.
5. Grease driveline shaft and all other grease fittings.
6. Clear area to be tilled of rocks, branches, and other foreign objects.
7. Tall grass and weeds should be mowed before tilling.
8. Do not engage power take-off at full throttle. Once engaged, increase throttle to 540 power take-off speed. Tiller tines will cut better at 540 power take-off speed than at reduced throttle.
9. Tilling should not be done in wet conditions as soil will stick to tines.
10. At first begin tilling at a slow forward speed and shift up as ground conditions warrant.
11. Operate tiller with deck level to the ground.
12. Tiller tines will cut better at 540 rpm power take-off speed.
13. After tilling the first 50 feet (15.25 m), stop and check to see that the tiller is adjusted properly.
14. Do not make turns or attempt to back up while tiller is in the ground. See important note above.
15. Do not engage power take-off with implement in the fully raised position.
16. Periodically check for foreign objects wrapped around the rotor shaft and remove them after disengaging power take-off, turning off tractor engine, and removing ignition key.

IMPORTANT: Turning or backing up with rotary tines in the ground will damage the tiller.

General Operating Instructions

- Before using your Rotary Tiller, you should have completely read the Operator's Manual, properly attached the tiller to the tractor, cut the driveline to proper length, run-in the clutch. If you have missed any of these steps, please complete them before proceeding.
- Now that you have properly prepared yourself and your tiller, it's time to do some tilling. Carefully drive the tractor to the site where you intend to till. You should have already cleaned this site of any large limbs, rocks, trash, metal or other debris. Best results will be achieved if you have mounted your tiller offset to the right far enough to cover the tread of your right tractor wheel. Line the tractor up just to the right of center on your tillage plot. You will be working from the center out and always turning to the right to line up for your next pass.
- Lower the tiller half way to the ground and reduce your tractor engine speed to about one quarter throttle. Engage the power take-off and gradually increase the engine speed until you reach full power take-off speed of 540 rpm. Lower the tiller to the ground and simultaneously commence forward travel of approximately 2 mph (3.2 km/h). Do not make turns or attempt to back up while tiller is in the ground. See important note below.

IMPORTANT: Turning or backing up with rotary tines in the ground will damage the tiller.

- Travel about 50 feet (15.25 m) and then stop to check your results. When stopping, remember to lift the tiller out of the ground, stop the tractor, reduce engine speed, disengage the power take-off, set the park brake, shut off the tractor, and remove the key. If you are tilling too shallow or too deep, adjust the skid shoes accordingly. If the soil texture is too coarse, lower the rear tailgate and reduce your ground speed. If the soil texture is too fine, you will need to raise your rear tailgate and increase your ground speed. For any other problem conditions that may arise, you will want to refer to the "Troubleshooting Chart".
- When you are done tilling for the day, make sure you use proper tractor shutdown procedures before you get off of the tractor. If you are detaching your tiller, make sure you park it on a dry and level surface leaving it clean and ready for the next use.

Skid Shoe Adjustment

The skid shoes can be adjusted to the desired tilling depth by raising or lowering them:

NOTE: Tilling depth is the vertical distance from bottom of skid shoes to bottom of lowest tine. Be certain both skid shoes are adjusted the same.

1. Raise tiller off the ground. Place support blocks under the tiller (not under the skid shoes) and lower tiller onto the supports. Make certain the tiller is secured while resting on the supports before working on or around the tiller.

2. The park stand should be in transport position. If it is not, move it to transport position now.
3. Always place tractor in park, set tractor brakes, shut tractor engine off and remove switch key before dismounting tractor.
4. Loosen pivot bolt at the shoe's front.
5. Remove adjusting bolt at the shoe's rear.
6. Adjust skid shoe to the desired tilling depth.
7. Reinstall adjusting bolt and lock washer. Tighten adjusting bolt and pivot bolt to the correct torque.

Section 3: Maintenance and Lubrication

Maintenance

Proper servicing and adjustments are key to the long life of any implement. With careful inspection and routine maintenance, you can avoid costly downtime and repair.

Check all hardware after several hours of operation and regularly thereafter to ensure they are tight and secured. Replace worn, damaged, or illegible safety labels by obtaining new labels.

Tine Replacement

WARNING To avoid serious injury or death:

Used tines can be very sharp. Always wear gloves when handling tines to protect against cuts.

IMPORTANT: When ordering tines, be sure to order only genuine OEM tines and to order both right- and left-hand tines.

Always install tines with cutting edge facing the direction of rotation.

IMPORTANT: Remove and install one tine at a time to ensure they are oriented correctly when installed

1. Remove the two hex nuts, lock washers, bolts, and tine to be replaced.
2. Attach new tine to the mounting flange making certain it is positioned so that the cutting edge crosses over the mounting flange and leads in rotation.
3. Replace removed bolts, lock washers, and hex nuts. Tighten hex nuts to the correct torque.
4. Repeat steps 1 to 3 until tines have been replaced.

Long-Term Storage

Clean, inspect, service, and make necessary repairs to the implement when storing it for long periods and at the end of the season. This will help to ensure the unit is ready for field use the next time you hook-up to it.

1. Clean off any dirt and grease that may have accumulated on the tiller and moving parts. Scrape off compacted dirt from bottom of tiller and then wash surface thoroughly with a garden hose.
2. Check tines and tine bolts for wear. Replace if necessary.
3. Inspect tiller for loose, damaged or worn parts and adjust or replace as needed.
4. Repaint parts where paint is worn or scratched to prevent rust.
5. A coating of oil may be applied to worn surfaces in lieu of painting to minimize oxidation.
6. Replace all damaged or missing decals.
7. Lubricate as noted in "Lubrication Points".
8. Drain and refill gearboxes oil. Be sure to replace all oil plugs when completed.
 - 1). Drain oil in central gearbox by removing bottom drain plug.
 - 2). Drain oil in side gearbox by removing bottom level plug and tipping tiller towards the plug hole.
9. Store tiller on a level surface in a clean, dry place. Inside storage will reduce maintenance and make for a longer tiller life.



Lubrication

Driveline Shaft U-Joints



Type of Lubrication: Grease

Quantity = 1-2 pumps

Driveline Shield Bearings



Type of Lubrication: Grease

Quantity = 4-6 pumps

Driveline Shaft

Disconnect driveline shaft from the tractor and slide apart. Clean and coat the inner tube of the driveline shaft with a light film of grease and then reassemble.



Type of Grease: Multi-Purpose

Quantity = Coat Generously

Bearing on Right End of Rotor Shaft



Type of Lubrication: Multi-purpose

Quantity = As Required

Central Gearbox

Check oil every 50 hours of operation by removing center level plug at the rear of the gearbox, oil should come to bottom of center plug hole. Add recommended gear lube through fill plug hole until oil begins to flow out of oil level plug hole. **DO NOT OVERFILL!**

Tighten all plugs when done.



Type of Lubrication: SAE 80-90W EP Oil

Quantity = Fill until oil begins to flow out of oil level plug hole.

Side Gearbox

Check oil every 50 hours of operation. Add recommended gear lube through fill plug hole until oil begins to flow out of lower plug hole (Put the tiller leveling). **DO NOT OVERFILL!**

Tighten all plugs when done.



Type of Lubrication: SAE 80-90W EP Oil

Quantity = Fill until oil begins to flow out of lower oil hole.



Section 4: Troubleshooting

Problem	Cause	Solution
Implement makes intermittent clicking noise	Tines are loose. Gearbox has tooth damaged.	Tighten tines. Replace damaged gearbox or gears
Driveline vibrates	Universal joint is worn. Excessive trash is wrapped on rotor. Implement is lifted too high.	Replace universal joint. Remove trash. Lower implement and readjust tractor lift stop.
Gearbox noise is noticeable and constant	May be normal on new implement. Low oil level. Worn gears.	Allow time for break-in. Add oil to the gearbox. Replace gears in the gearbox.
Oil leaking from gearbox	Seals and/or gaskets are damaged. Gearbox is overfilled.	Replace seals or gaskets in the gearbox. Drain oil to proper level.
Rotor will not turn	power take-off is not engaged. Drive chain is broken. Friction clutch is slipping.	Engage power take-off. Repair drive chain. Reduce tiller load or replace/service clutch.
Tillage depth insufficient	Tiller is carried by tractor. Tractor has insufficient power. Skid Shoes need adjusting. Tines are worn or bent. Tines are incorrectly installed. Obstacles are entangled in tines and/or rotor. Lower hitch clevises are in the wrong position.	Lower tractor 3-point arms. Increase power take-off speed to 540 rpm. Adjust skid shoes. Replace tines. Check tine placement. Clear rotor and/or tines of obstacles. Relocate lower hitch clevises.
Soil texture too coarse	Tailgate is set too high. power take-off speed is too slow. Ground speed is too fast.	Lower tailgate. Increase power take-off speed to 540 rpm. Decrease ground speed.
Soil texture too fine	Tailgate is set too low. Ground speed is too slow.	Raise tailgate. Increase Ground Speed.
Implement skips or leaves crop residue	Tines are badly worn. Friction clutch is slipping. Ground speed is too fast for conditions.	Replace worn tines. Reduce load. Reduce ground speed.
Tines operating behind tractor tires show increased wear	Tractor tires can compact soil causing tines that operate in the compacted soil to have increased wear.	Considered as normal wear. Replace worn tines.
Tines balling up with soil	Tines are worn or bent. Tines are incorrectly installed. Rear tailgate is set too low. Tractor speed is too fast. Soil is too wet.	Replace tines. Install tines correctly. Raise rear tailgate. Decrease tractor speed. Wait until soil dries.
Tiller bumping on ground	Obstacles are entangled in tines and/or rotor. Tines are not installed correctly.	Clear rotor and/or tines. Install tines correctly.



Section 5: Appendix

Bolt Torque

The tables shown below give correct torque values for various bolts and cap screws. Tighten all bolts to the torques specified unless otherwise noted. Check tightness of bolts periodically, using bolt torque chart as a guide. Replace hardware with the same strength bolt.

ENGLISH TORQUE SPECIFICATIONS

Bolt Diameter	Bolt Torque					
	SAE 2		SAE 5		SAE 8	
	N.m	lb-ft	N.m	lb-ft	N.m	lb-ft
1/4"	8	6	12	9	17	12
5/16"	13	10	25	19	36	27
3/8"	27	20	45	33	63	45
7/16"	41	30	72	53	100	75
1/2"	61	45	110	80	155	115
9/16"	95	60	155	115	200	165
5/8"	128	95	215	160	305	220
3/4"	225	165	390	290	540	400
7/8"	230	170	570	420	880	650

METRIC TORQUE SPECIFICATIONS

Bolt Diameter	Bolt Torque			
	8.8		10.9	
	N.m	lb-ft	N.m	lb-ft
M3	0.5	0.4	1.8	1.3
M4	3	2.2	4.5	3.3
M5	6	4	9	7
M6	10	7	15	11
M8	25	18	35	26
M10	50	37	70	52
M12	90	66	125	92
M14	140	103	200	148
M16	225	166	310	229
M20	435	321	610	450
M24	750	553	1050	744
M30	1495	1103	2100	1550
M36	2600	1917	3675	2710

Torque figures indicated above are valid for non-greased or non-oiled threads and heads otherwise specified. Therefore, do not grease or oil bolts or cap screws unless otherwise specified in this manual. When using locking elements, increase torque values by 5%.



Section 6. Part List

A. TMG-RT165/RT185 Rotary Tiller Covering Assembly

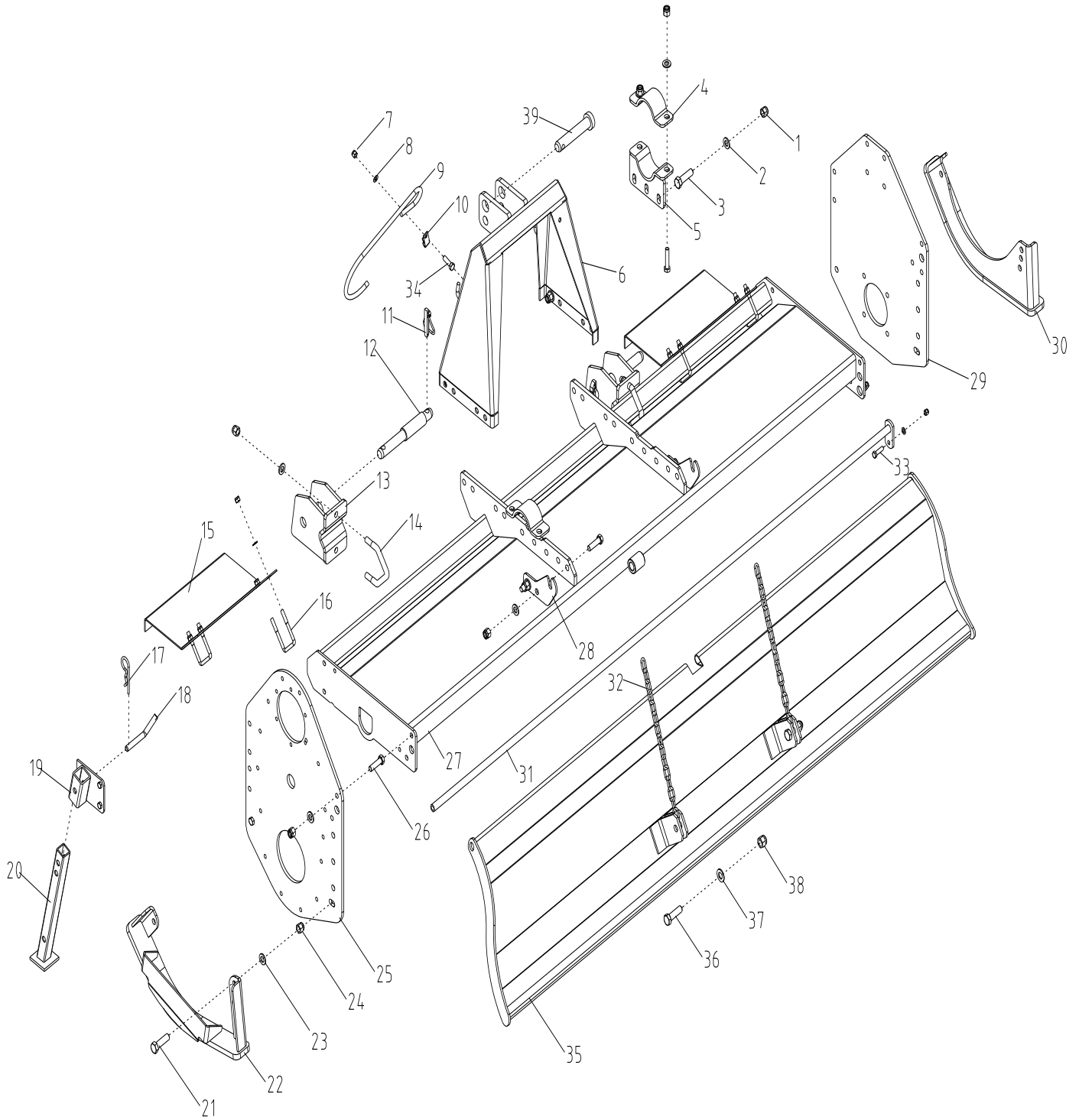

Part No.	Ref. No.	Parts Description	Qty
A1	GB/T889.1-2000	Nut M12	24
A2	GB/T97.1-2002	Plain washer 12	24
A3	GB/T5782-2002	Bolt M12*40	20
A4	1GR185.01.302	Fixed block	2
A5	1GR185.01.016	U-block Welding Joints	2
A6	1GR185.01.013	Hitch	1
A7	GB/T889.1-2000	Nut M8	10
A8	GB/T97.1-2002	Plain washer 8	10
A9	1GR185.01.301	hook	1
A10	1GR185.01.307	Shrapnel	1
A11	FEL300.111	Lock pin 12	2
A12	AM80.01.101	Lower suspension pin	2
A13	1GR185.01.020	Lower suspension weldment	2
A14	1GR185.01.308	Hoop	2
A15	1GR185.01.303	Two folded plates	2
A16	1GR185.01.306	Square hoop	4
A17	1GN230.01.104	R pin \varnothing 3.2	3
A18	1GR185.01.305	Foot pin	1
A19	1GR185.01.012	Connecting plate weldment	1
A20	1GR185.01.019	Supporting frame	1
A21	GB/T5782-2002	Bolt M10*35	20
A22	1GR185.01.017	Limiting depth linkage plate(R)	1
A23	GB/T97.1-2002	Plain washer 10	12
A24	GB/T889.1-2000	Nut M10	12
A25	1GR185.01.021	Big lateral plate weldment	1
A26	GB/T5782-2002	Bolt M10*30	8
A27	1GR185.01.014	Cover weldment	1
A28	1GR185.01.304	Chain hanging plate	2
A29	1GR185.01.102	Small side plate	1
A30	1GR185.01.018	Limiting depth linkage plate(L)	1
A31	1GR185.01.015	Long pin welded joint	1
A32	1GN230.01.017	Link	2
A33	GB/T5782-2002	Bolt M8*30	1
A34	GB/T5782-2002	Bolt M8*25	1
A35	1GR185.01.011	Big dam-board weldment	1
A36	GB/T5782-2002	Bolt M14*50	2
A37	GB/T97.1-2002	Plain washer 14	2
A38	GB/T889.1-2000	Nut M14	6
A39	1GR185.01.309	Upper suspension pin	1



B. TMG-RT165/RT185 Rotary Tiller Central Gearbox Assembly

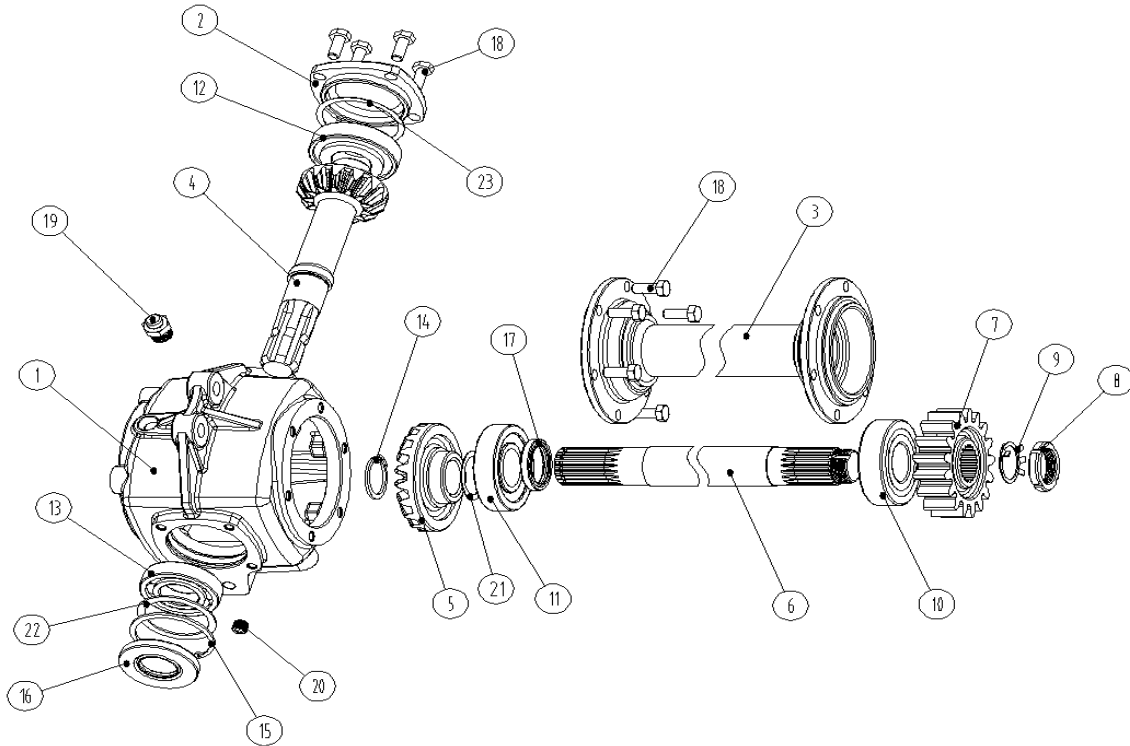

Part No.	Ref. No.	Parts Description	Qty
B1	0.RTD30.2047.00	Gearbox housing	1
B2	1.RTD30.1025.00	Solid Cover	1
B3	0.RTD30.5015.00	Spacer	1
B4	2.RTD30.3055.00	Pinion Shaft	1
B5	3.RTD30.2091.00	Forging Gear	1
B6	2.RTD30.2095.00	Output Shaft	1
B7	3.RTD30.1002.00	Cylindrical gear	1
B8	6.5.1.00010	Nut M35*1.5	1
B9	6.6.3.00002	Lock Washer 35	1
B10	6.1.6.00034	Bearing 6308-2RS	1
B11	6.1.6.00011	Bearing 30308	1
B12	6.1.6.00008	Bearing 30307	1
B13	6.1.6.00003	Bearing 6207	1
B14	6.6.4.00003	Snap Ring For Shaft 40*2.5	1
B15	6.6.6.00003	Snap Ring For Hole 72*2.5	1
B16	6.2.1.00002	Dust lip Oil Seal 35*72*10	1
B17	6.2.1.00032	Dust lip Oil Seal 40*54*8	1
B18	6.4.1.00001	Hexagon Bolt M10*25	10
B19	6.8.2.00003	Oil vent plug 1/2" Gas	1
B20	6.8.1.00001	1/4" Gas Solid Plug	1
B21	7.313.0033.00	Shim kit 40.3*51.5	1
B22	7.CT150.0020.00	Shim kit 58*71.5	1
B23	7.313.0038.00	Shim kit 69*79.7	1

C. TMG-RT165/RT185 Rotary Tiller Rotor Shaft Assembly

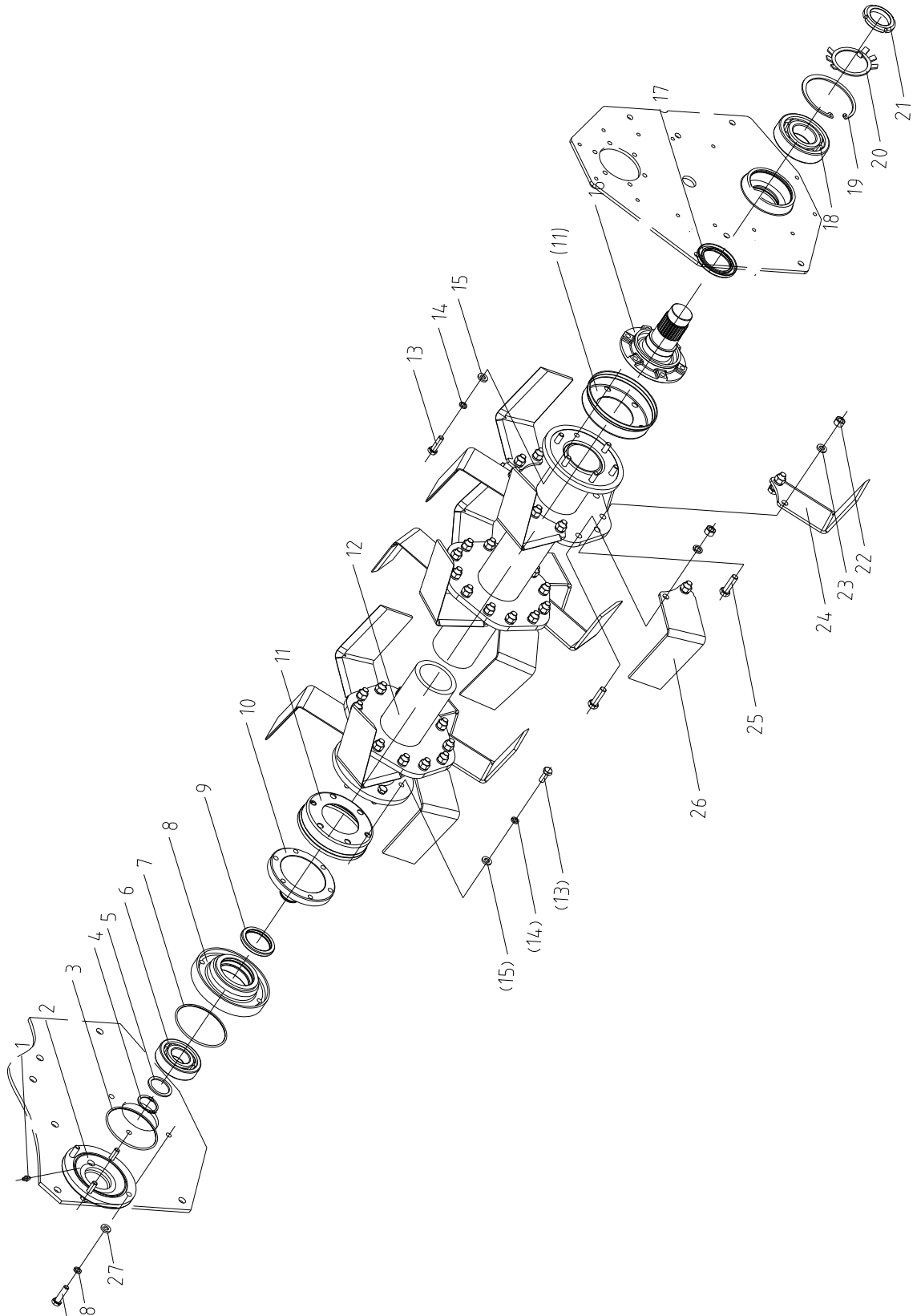

Part No.	Ref. No.	Parts Description	Qty
C1	JB/T7940.1-1995	Oil cup M8*1	1
C2	1GN230.03.101	Side cover	1
C3	GB/T3452.1-1992	O-ring 112*119.1*3.55	1
C4	GB/T894.1-1986	Circlip 35	1
C5	1GR135.03.104	Washer (L)	1
C6	GB/T276-1994	Bearing 6307	1
C7	GB/T3452.1-1992	O-ring 106*113.1*3.55	1
C8	1GR185.03.103	Outer side support	1
C9	GB/T13871-1992	Oil seal FB45*62*8	1
C10	1GR185.03.105	Outer side hub	1
C11	1GN230.03.105	Exterior dust cover	2
C12	1GR185.03.011	Blades holder rotor	1
C13	GB/T5782-2000	Bolt M12*35	12
C14	GB/T93-2002	Spring washer 12	12
C15	GB/T97.1-2002	Flat washer 12	12
C16	1GR185.03.106	Drive side hub	1
C17	GB/T13871-2007	Oil seal FB55*72*8	1
C18	GB/T276-1988	Bearing 6309	1
C19	GB/T893.1-1986	Circlip 100	1
C20	GB/T858-1988	Self locking nut 45	1
C21	GB/T858-1988	Self locking nut M35	1
C22	GB/T889.1-2000	Nut M12*1.25	108 -- TMG-RT185 96 --TMG-RT165
C23	GB/T97.1-2002	Flat washer 12	108 -- TMG-RT185 96 --TMG-RT165
C24	1GR185.03.102	Left helicoidal blade	27 -- TMG-RT185 24 --TMG-RT165
C25	GB/T5783-2000	Bolt M12*1.25*35	108 -- TMG-RT185 96 --TMG-RT165
C26	1GR185.03.101	Right helicoidal blade	27 -- TMG-RT185 24 --TMG-RT165
C27	GB/T97.1-2002	Flat washer 10	4
C28	GB/T93-2002	Spring washer 10	4
C29	GB/T5782-2000	Bolt M10*40	4



D. TMG-RT165/RT185 Rotary Tiller Transmission Assembly

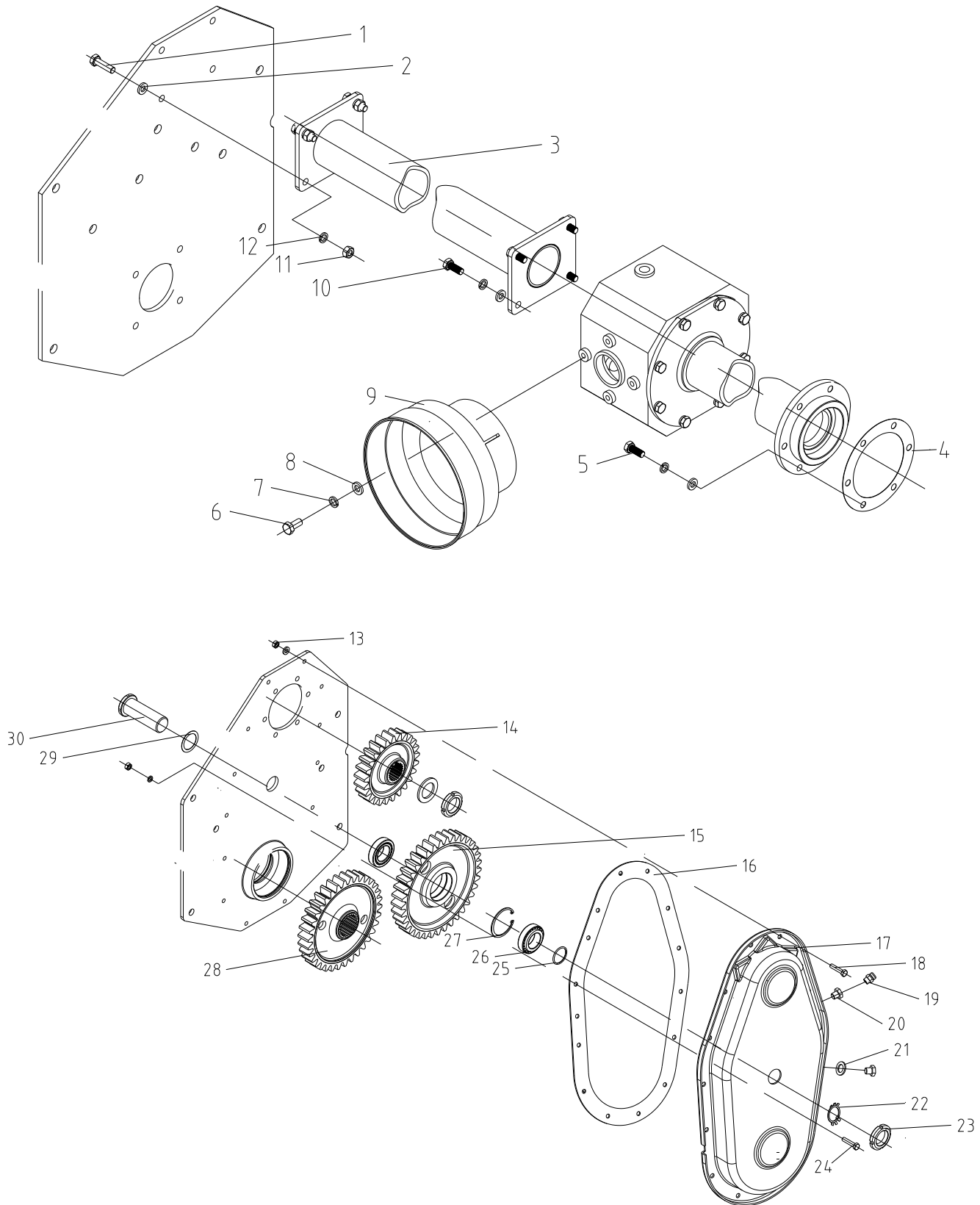

Part No.	Ref. No.	Parts Description	Qty
D1	GB/T5783-2000	Bolt M10*30	4
D2	GB/T97.1-2000	Plain washer 10	16
D3	1GR185.04.011	Outer spacer	1
D4	1GR185.02.105	Gasket	1
D5	GB/T5782-2000	Bolt M10*1*20	6
D6	GB/T5783-2000	Bolt M8*16	4
D7	GB/T93-2002	Spring washer 8	8
D8	GB/T97.1-2000	Plain washer 8	23
D9	1G135.02.117	Guard shade	1
D10	GB/T5782-2000	Bolt M10*25	4
D11	GB/T889.1-2000	Nut M10	4
D12	GB/T93-2002	Spring washer 10	10
D13	GB/T889.1-2000	Nut M8	15
D14	1GR185.04.101	Upper gear	1
D15	1GR185.04.102	Central gear	1
D16	1GR185.04.104	Drive cover gasket	1
D17	1GR185.04.012	Gears cover	1
D18	GB/T5783-2000	Bolt M8*25	13
D19		Oil breather plug	1
D20	1GN230.02.117	Bolt M16x1.5	1
D21	JB/T1002-1977	Gasket 16	2
D22	GB/T858-1988	Self locking nut 24	1
D23	GB/T812-1988	Self locking nut M24*1.5	1
D24	GB/T5783-2000	Bolt M8*30	2
D25	GB/T3452.1-1992	O-ring 29.5*34.8*2.65	1
D26	GB/T297-1994	Bearing 30306	2
D27	GB/T893.1-1986	Circlip 42	1
D28	1GR185.04.103	Lower gear	1
D29	GB/T3452.1-1992	O-ring 34.5*39.8*2.65	1
D30	1GR185.04.105	Gear hub	1

