

MODEL TMG-PSM27

27" CUTTING CAPACITY PORTABLE SAWMILL

KOHLER COMMAND PRO SERIES ENGINE

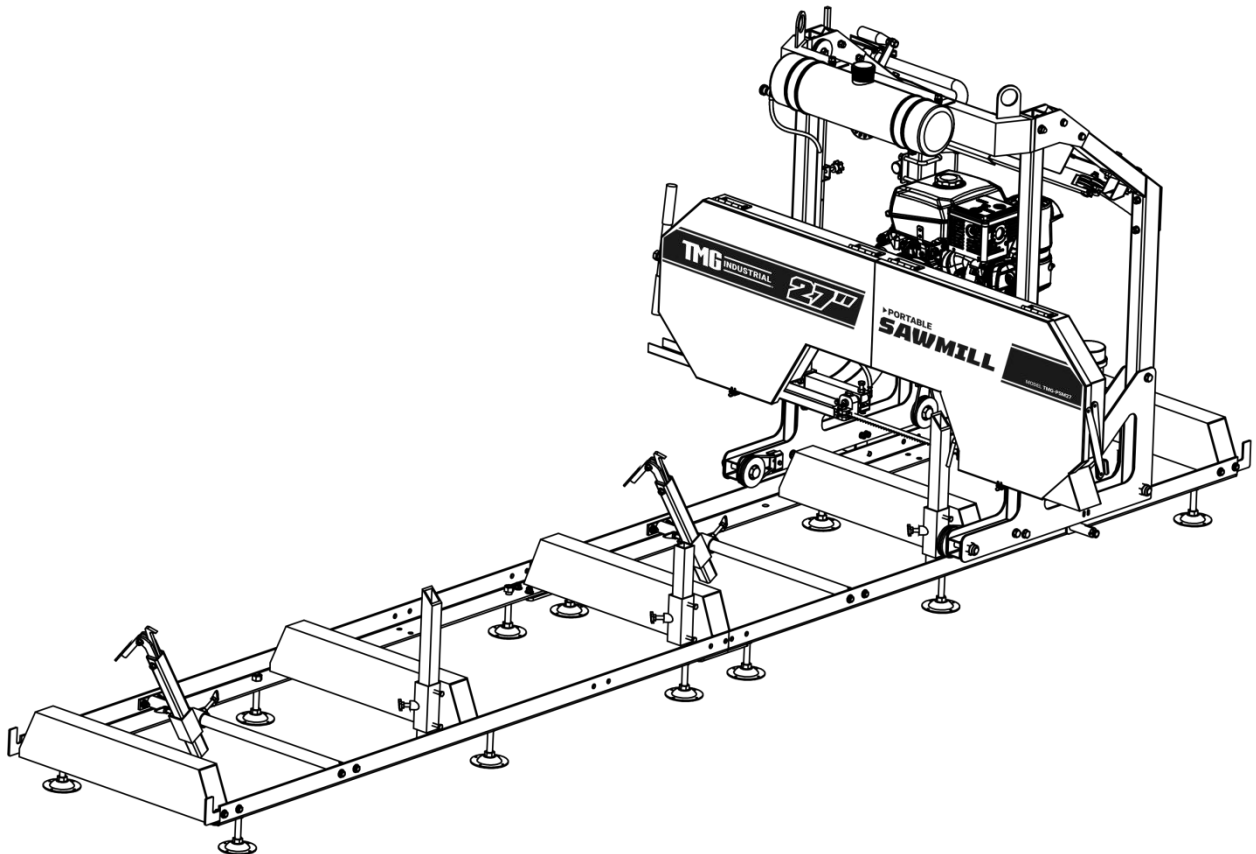

⚠ WARNING



- Please read and understand the product manual completely before assembly
- Check against the parts list to make sure all parts are received
- Wear proper safety goggles or other protective gears while in assembly
- Do not return the product to dealer. They are not equipped to handle your requests.

Missing parts or questions on assembly?

Please call: 1-877-761-2819 or email: cs@tmgindustrial.com

Contents

| | |
|--|-----------|
| GENERAL SAFETY RULES | 3 |
| GENERAL MAINTENANCE INFORMATION | 7 |
| SAWMILL ASSEMBLY INSTRUCTIONS | 8 |
| Inspection | 8 |
| Tracks | 8 |
| Log Dog & Supports | 10 |
| Carriage Assembly | 12 |
| Electric Wire Connect | 24 |
| Engine | 25 |
| SAWMILL SET-UP PROCEDURES | 26 |
| Belt Tension | 26 |
| Blade Tracking | 27 |
| Blade Guide Adjustment | 31 |
| Blade Tension | 32 |
| SAWMILL MAINTENANCE | 34 |
| Changing the Blade | 34 |
| Replacing Belts | 34 |
| TROUBLESHOOTING | 36 |
| PART DIAGRAMS | 37 |
| PARTS LIST | 39 |

Thank you very much for choosing the **TMG-PSM27** Portable Sawmill. For future reference, please complete the owner's purchase date:

Save the receipt for warranty and these instructions. **It is important that you read the entire manual to become familiar with this product before you begin using it.**

This machine is designed for certain applications only. We strongly recommend this machine is not modified and/or used for any application other than that for which it was designed. If you have any questions relative to a particular application, DO NOT use the machine until you have first contacted us to determine if it can or should be performed on the product.

For technical questions and replacement parts, please contact TMG Industrial-A division of Transcan Motorsports Inc.

INTENDED USE

This sawmill is designed for sawing logs while the mill is firmly supported on the ground.

TECHNICAL SPECIFICATIONS

| Item | Description |
|----------------------|----------------------------|
| Engine | 14 HP Kohler |
| Maximum Log Diameter | 27" (685mm) |
| Maximum Board Width | 21-1/2" (548mm) |
| Blade Size | 1-1/4 x 144" (32 x 3658mm) |

GENERAL SAFETY RULES

 **WARNING: Read and understand all instructions.** Failure to follow all instructions listed below may result in electric shock, fire and/or serious injury.

 **WARNING: The warnings, cautions, and instructions discussed in this instruction manual cannot cover all possible conditions or situations that could occur.** It must be understood by the operator that common sense and caution are factors which cannot be built into this product, but must be supplied by the operator.

 **WARNING: Only operate the engine in a well ventilated area.** Carbon Monoxide produced by the engine during use can kill. Do not use indoors, near windows or in other sheltered areas.

NOTE: All Federal and State laws and any regulation having jurisdiction covering the safety requirements for use of the machine take precedence over the statements in this manual. Users of this machine must adhere to such regulations.

SAVE THESE INSTRUCTIONS

WORK AREA

- **Keep work area clean**, free of clutter and well lit. Cluttered and dark work areas can cause accidents.
- **Do not use your sawmill where there is a risk of causing a fire or an explosion;** e.g. in the presence of flammable liquids, gasses, or dust. Power tools create sparks, which may ignite the dust or fumes.
- **Keep children and bystanders** away while operating a power tool. Distractions can cause you to lose control, so visitors should remain at a safe distance from the work area.
- **Be aware of all power lines, electrical circuits,** water pipes and other mechanical hazards in your work area, particularly those hazards below the work surface hidden from the operator's view that may be unintentionally contacted and may cause personal harm or property damage.
- **Be alert of your surroundings.** Using power tools in confined work areas may put you dangerously close to cutting tools and rotating parts.

INTERNAL COMBUSTION ENGINE SAFETY



WARNING: Internal combustion engines present special hazards during operation and fueling. Read and follow the warning instructions in the engine Owner's Manual and the safety guidelines below. Failure to follow the warnings and safety standards could result in severe injury or death.

- **DO NOT** run the machine indoors or in an enclosed area such as a deep trench unless adequate ventilation, through such items as exhaust fans or hoses, is provided. Exhaust gas from the engine contains poisonous carbon monoxide gas; exposure to carbon monoxide can cause loss of consciousness and may lead to death.
- **DO NOT** smoke while operating the machine.
- **DO NOT** smoke when refueling the engine.
- **DO NOT** refuel a hot or running engine.
- **DO NOT** refuel the engine near an open flame.
- **DO NOT** spill fuel when refueling the engine.
- **DO NOT** run the engine near open flames.
- **ALWAYS** refill the fuel tank in a well ventilated area.
- **ALWAYS** replace the fuel tank cap after refueling.
- **ALWAYS** check the fuel lines and the fuel tank for leaks and cracks before starting the engine. Do not run the machine if fuel leaks are present or the fuel lines are loose.
- **ALWAYS** avoid contact with hot fuel, oil, exhaust fumes and solid surfaces.

PERSONAL SAFETY

- **Stay alert**, watch what you are doing and use common sense when operating a power tool. Do not use a power tool while you are tired or under the influence of drugs, alcohol or medication. A moment of inattention while operating power tools may result in serious personal injury.
- **Dress properly**. Do not wear loose clothing, dangling objects, or jewelry. Keep your hair, clothing and gloves away from moving parts. Loose clothes, jewelry or long hair can be caught in moving parts. Air vents often cover moving parts and should be avoided.
- **Use safety apparel and equipment**. Use safety goggles or safety glasses with side shields which comply with current national standards, or when needed, a face shield. Use a dust mask in dusty work conditions. This applies to all persons in the work area. Also use non-skid safety shoes, hardhat, gloves, dust collection systems, and hearing protection when appropriate.
- **Do not over reach**. Keep proper footing and balance at all times.
- **Remove adjusting keys or wrenches** before connecting to the power supply or turning on the tool. A wrench or key that is left attached to a rotating part of the tool may result in personal injury.
- **Never make blade guide adjustments, remove or install blades or conduct any other maintenance or make any other adjustments when the engine is running**. Always shut the engine off, remove the ignition key, and keep the engine off before carrying out any of the aforementioned procedures. Consult your engine manual for safe shutdown procedures to prevent accident ignition.

TOOL USE AND CARE

- **Always** be sure operator is familiar with proper safety precautions and operation techniques before using machine.
- **Never touch** the engine or muffler while the engine is on or immediately after it has been turned off. These areas get hot and may cause burns.
- **Always** close fuel valve on engines when machine is not being operated.
- **Avoid "kick-back"** by knowing what conditions can create it.
- **Do not force the tool**. Tools do a better and safer job when used in the manner for which they are designed.
- **Never use the sawmill** with a malfunctioning switch or throttle. Any power tool that cannot be controlled with the switch is dangerous and must be repaired before using.
- **Turn off the engine** and place the switch in the locked or off position before servicing, adjusting, installing accessories or attachments, or storing. Such preventive safety measures reduce the risk of starting the power tool accidentally.
- **Secure logs** with the log screw clamping device instead of with your hand or another individual's help. This safety precaution allows for proper tool operation using both hands.
- **Storing sawmill**. When the sawmill is not in use, store it in a dry, secure place or keep well covered and out of the reach of children. Inspect the sawmill for good working condition prior to storage and before re-use.
- **Maintain your sawmill**. It is recommended that the general condition of the sawmill be examined before it is used. Keep your sawmill in good repair by adopting a program of conscientious repair and maintenance in accordance with the recommended procedures found in this manual. If any abnormal vibrations or noise occurs, turn the sawmill off immediately and have the problem

corrected before further use.

- **Keep saw blades sharp and clean.** Properly maintained band saw blades are less likely to bind and are easier to control.
- **Cleaning and Lubrication.** Use only soap and a damp cloth to clean your sawmill. Many household cleaners are harmful to plastic and rubber components on the sawmill.
- **Use only accessories that are recommended** by the manufacturer for your model. Accessories that may be suitable for another sawmill may create a risk of injury when used on the GT26 sawmill.
- **Always** operate machine with all safety devices and guards in place and in working order. DO NOT modify or make changes to safety devices. DO NOT operate machine if any safety devices or guards are missing or inoperative.
- **Never leave sawmill running unattended.**
- **Coiled blades can spring apart with considerable force and unpredictably in any direction.** Always deal with coiled blades, including those packaged in boxes, with the utmost care.
- **Never use the equipment to cut anything other than lumber** or for any purpose other than cutting lumber as described in this manual.

START UP PROCEDURE - EQUIPMENT OPERATION

1. Wear heavy-duty work gloves, ANSI-approved goggles behind a full face shield, steel-toed work boots, and a dust mask.
2. Operate only with assistance.
3. Ensure guide blocks are tight and track is level
4. Fill the lubrication tank with clean water and *washing up detergent*.
5. Start and operate the engine according to the provided engine manual.
6. Depress the throttle to bring the blade up to *full* speed.
7. Throttle should be *fully depressed* when the saw is *under load*.
8. Cut branches off the lumber to be processed.
9. **WARNING:** to avoid death or serious injury. Do not cut lumber with foreign objects in it such as nails, any metal pieces, etc.
10. Place the lumber to be cut on the supports.
11. **WARNING:** The operator and any assistants must stay clear of the front and back of the blade whenever the engine is on.
12. Move the saw head slowly along the track and against the lumber to make the cut.
13. Trim off the rounded sides of the log.
14. When the log is squared-off, boards or posts can be cut to custom specifications.
15. To prevent accidents, turn off the engine and disconnect its spark plug wire after use. Wait for the engine to cool, clean external parts with a clean cloth, then store the equipment out of children's reach.

MAINTENANCE

Proper and routine maintenance is critical to operator safety, achieving good milling results and to prolonging the life of your investment.

1. **Band wheel Bearings** – Should be inspected before use to ensure they are not worn. Bearings are sealed and do not need to be greased.
2. **Blade Guide Bearings** – Inspect before use for excessive grooves or scoring in the bearing case. Replace if necessary.
3. **Blade Tension** – Grease threads of tensioning “T” handle when dry or as required. Use multi-purpose, extreme-pressure grease.
4. **Log Screws** – Grease frequently.
5. **Belts** – Periodically check the condition and wear of the drive and idler belt. Ensure that the blade does not ride on the band-wheels.
6. **Drive Belt** – Periodically check the tension of the drive belt. It should deflect by no more than 1/2".
7. **Saw-Head Locking Cam Handles** – Grease assembly every 30 days or as required.
8. **Saw-Head Vertical Posts** – Spray posts before use with a silicone spray lubricant such as 3- in-1 or Jig-A-Loo.
9. **Band-Wheel Guards** – Routinely remove any build-up of sawdust that may collect inside the band-Wheel guards.
10. **Lubrication Tank** – Only fill with a water/washing up detergent mixture(one to two caps) or in winter months, use windshield washer fluid. Do not leave lubricant in tank if temperatures fall below 0 degrees Celsius.
11. **Blade Lubricant** – Never use diesel fuel or kerosene as blade lubricant. These substances lead to premature wear of your belts and poor sawing performance. For winter operations, replace the water lubricant with windshield washer fluid.
12. **Engine** – Check the engine oil level before each use and maintain the engine as per the instructions set out by the engine manufacturer in the engine manual.
13. **Sawhead Lifting Cables** – Regularly before, during and after operations, inspect the cables for any wear or kinks. Ensure that the cables are in perfect condition. Oil coiled part of cable often to prevent premature wear. Replace with new cables as necessary.

SAWMILL ASSEMBLY

#1 – INSPECTION

Take all of the parts out of the shipping crate and lay them out.

#2 – TRACKS

Assemble track system and secure loosely with provided nuts & bolts. It is important not to fully tighten the bolts at this stage. This will be done after the head is assembled and rolled along the track. It is ideal to assemble the tracks on a solid and level footing that is a minimum of 4" off of the ground – We recommend you attach the leveling legs to sleepers which we discuss later in the instruction manual). This will allow for easy cleanup of sawdust from under the tracks and height adjustment of the log supports and also easier leveling of the track.

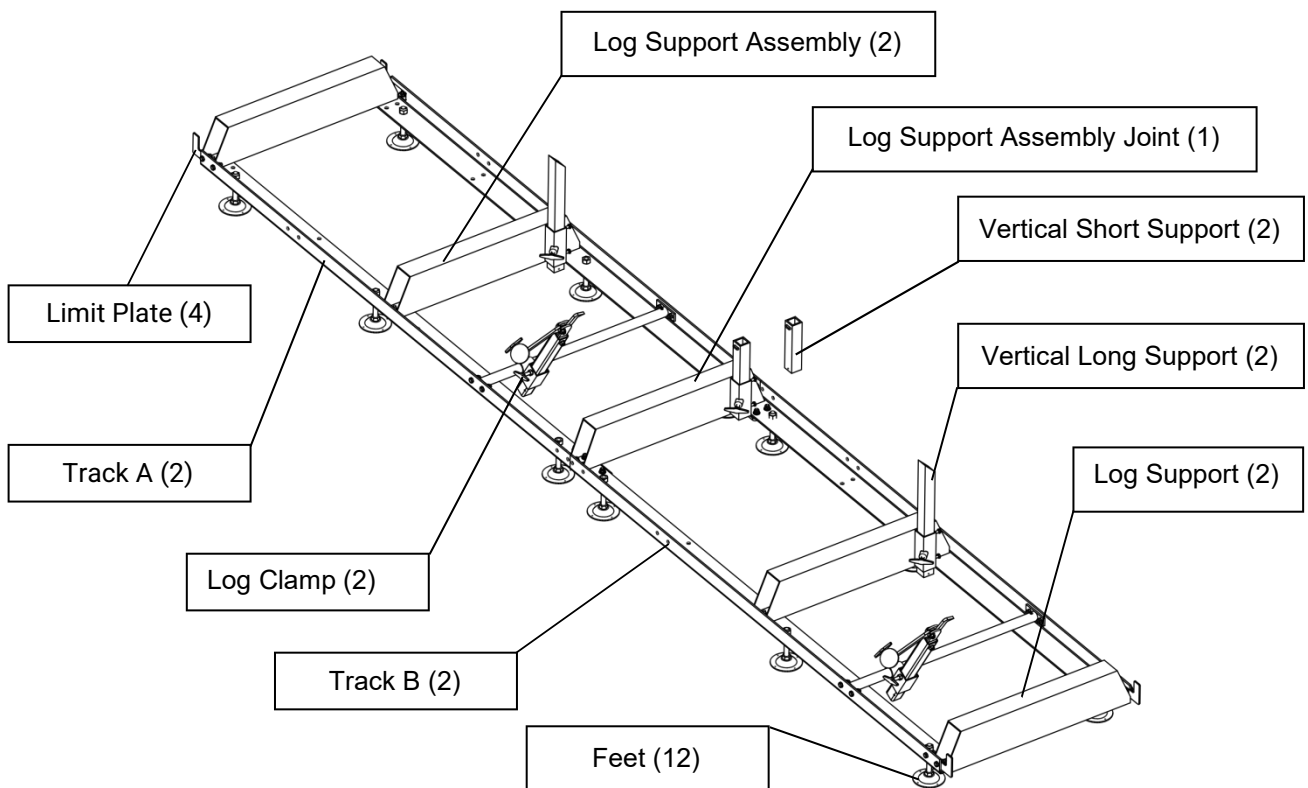

1. Install leveling feet and fasteners to the track, and install the sliding tube base on the track, repeat the above installation until all four are complete

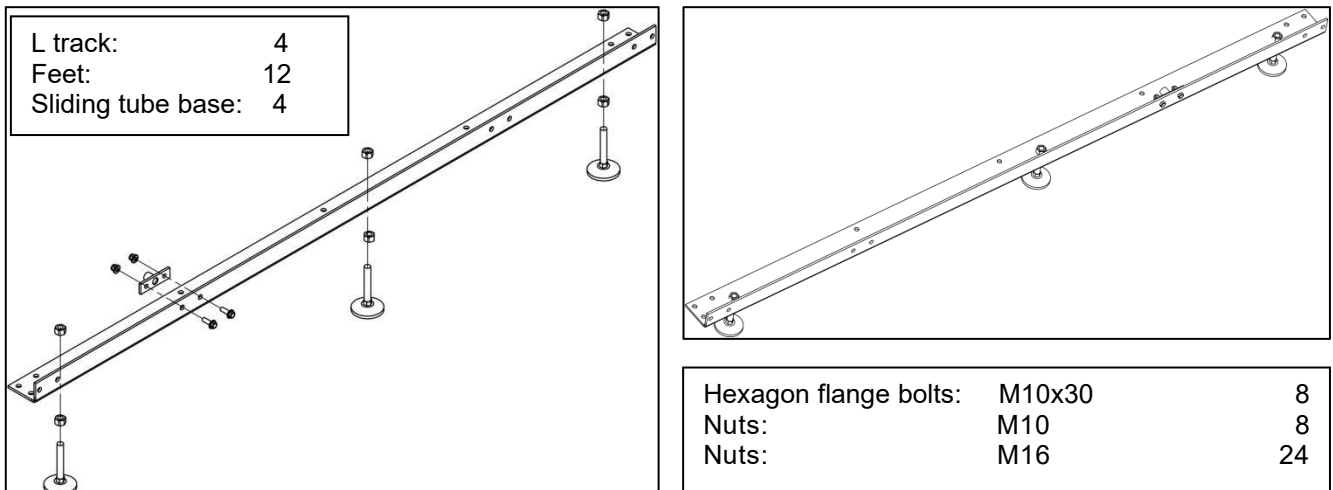

2. Attach track cross supports to "L" channel with the provided nuts & bolts. The joining plate is used at the seam joint to join the two sections together (shown in right-down image). Ensure to only hand tighten at this stage. The bolts will be fully tightened once the head assembly is free to roll on the tracks and provide the correct track width.

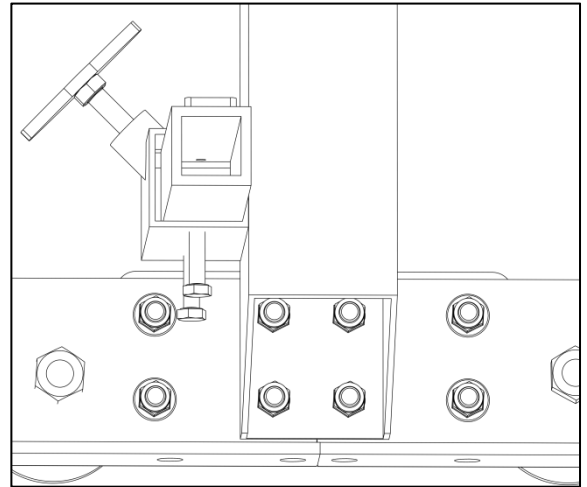
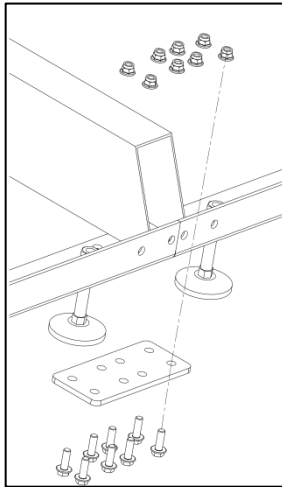
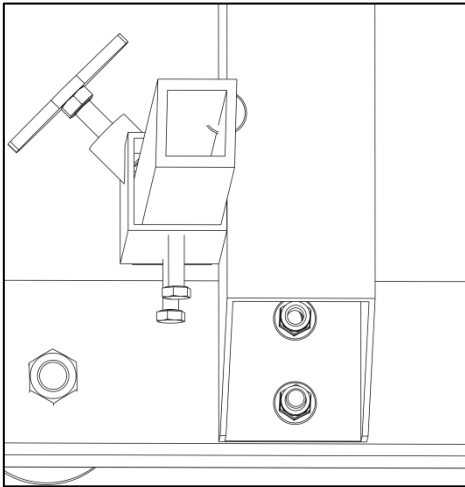

| | | |
|-----------------------|--------|----|
| Hexagon flange bolts: | M10x30 | 16 |
| Nuts: | M10 | 16 |

| | | |
|-----------------------|--------|----|
| Hexagon flange bolts: | M10x30 | 16 |
| Nuts: | M10 | 16 |

3. Assemble carriage stops at the ends of the tracks (4 stops total) and tighten.

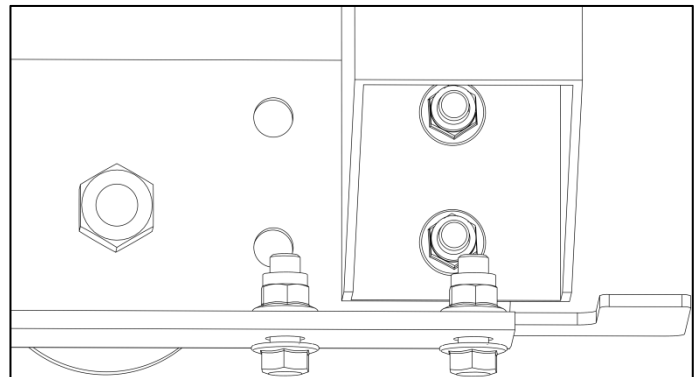
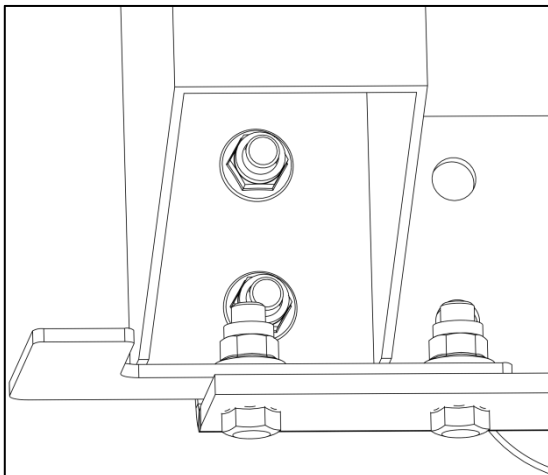

| | | |
|-----------------------|--------|---|
| Hexagon flange bolts: | M10x30 | 8 |
| Nuts: | M10 | 8 |

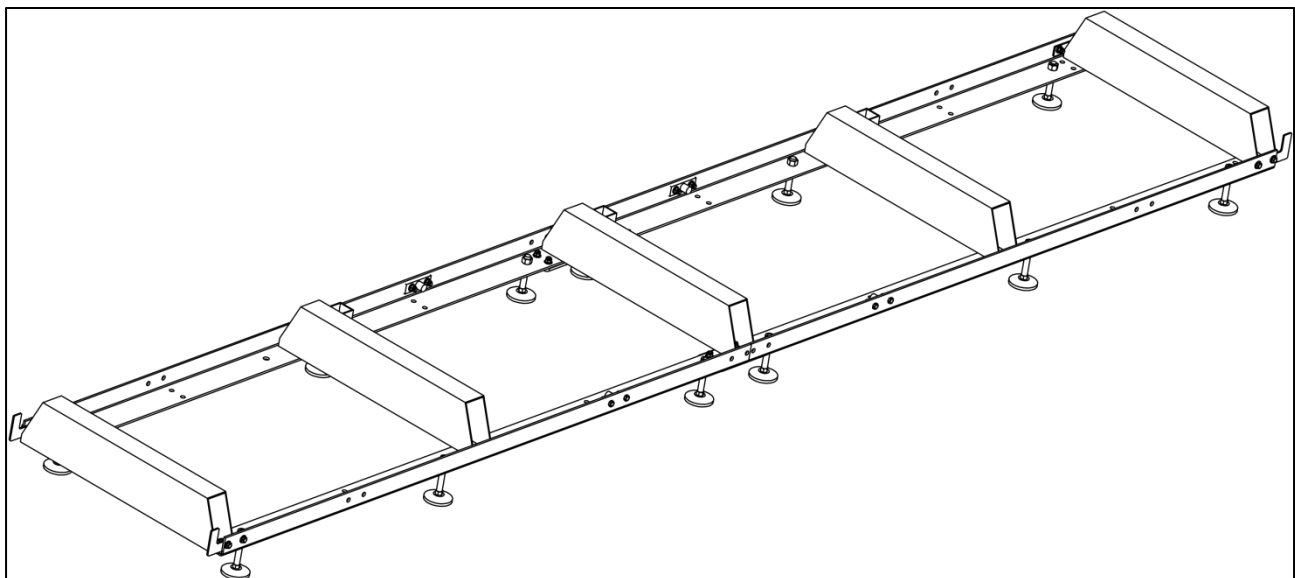

#3 – LOG DOG & SUPPORTS

Assemble log dog pieces as shown below and use water proof grease on threaded handle and “T” handle.

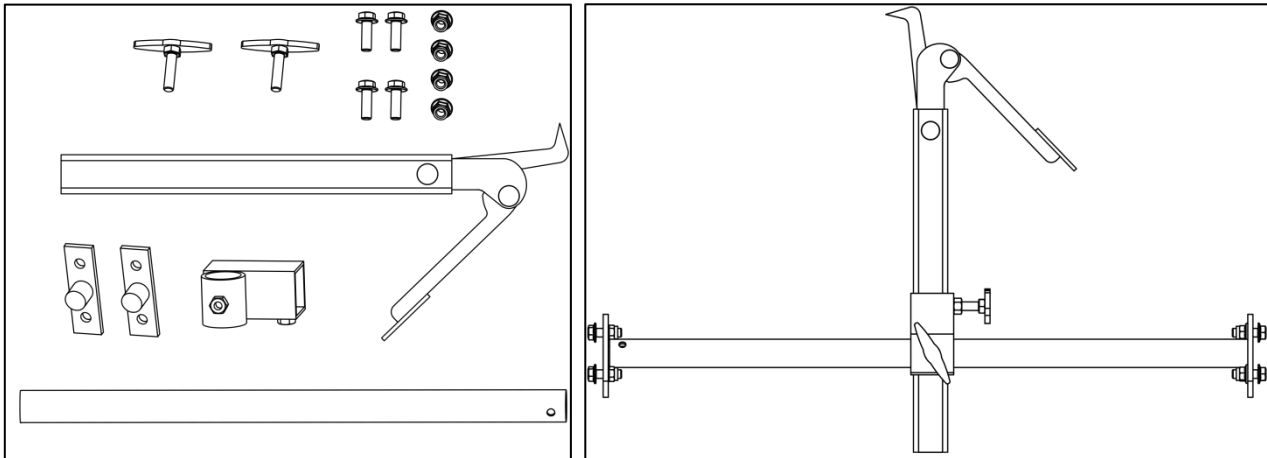

Attach assembly to the track using the provided nuts & bolts and tighten. Attach log dog assembly to track as shown below with the 4 nuts and bolts provided. Note that there are various locations along the track where this assembly can be bolted. Depending on how many track sections are being used, select a log clamp position that will secure the log firmly against the log supports.

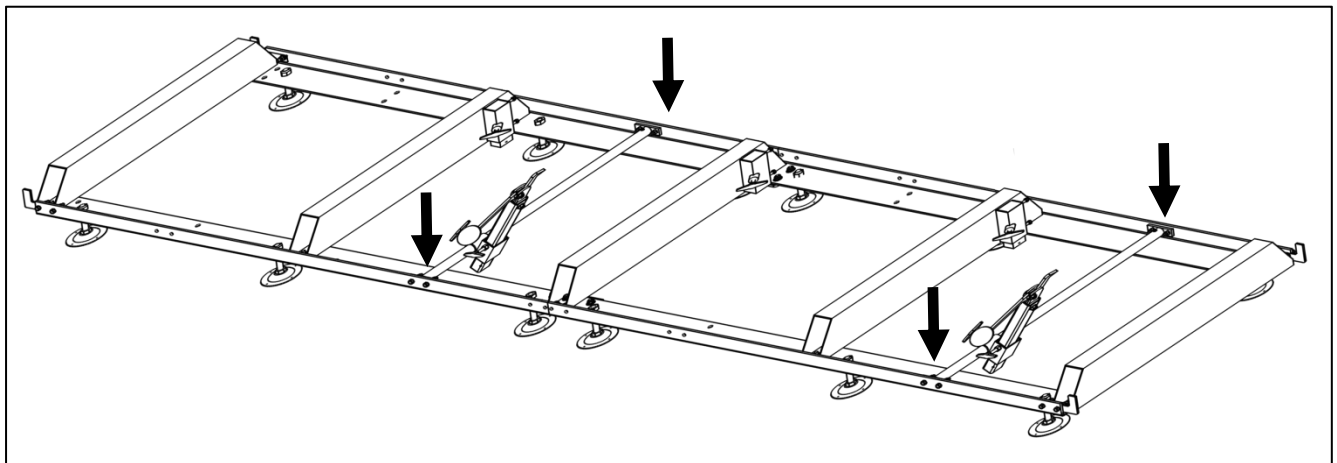

Insert log supports into track cross supports and secure with “T” handles. The “T” handle threads should be coated with waterproof grease. The sawmill includes two sets of log supports – a short set and a long set. The longer set is ideal for larger logs and the shorter set is ideal for small logs and square cants.

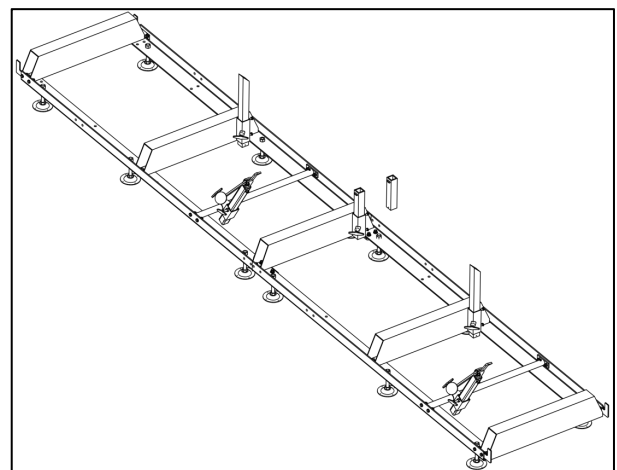
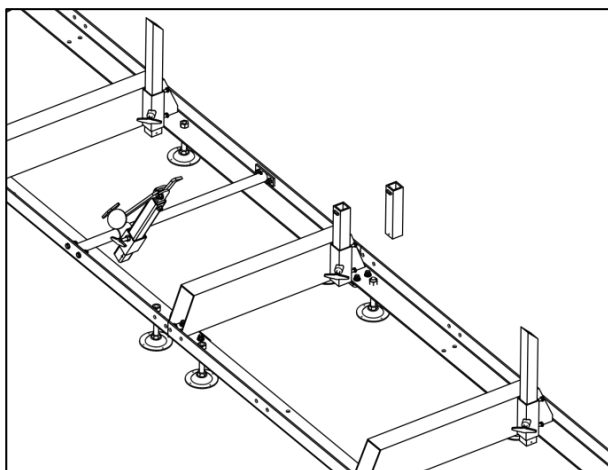

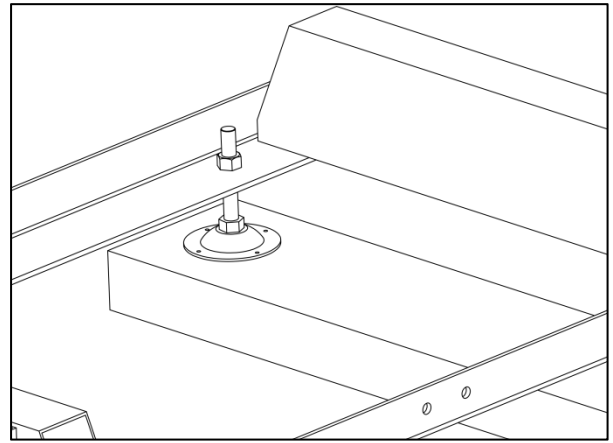
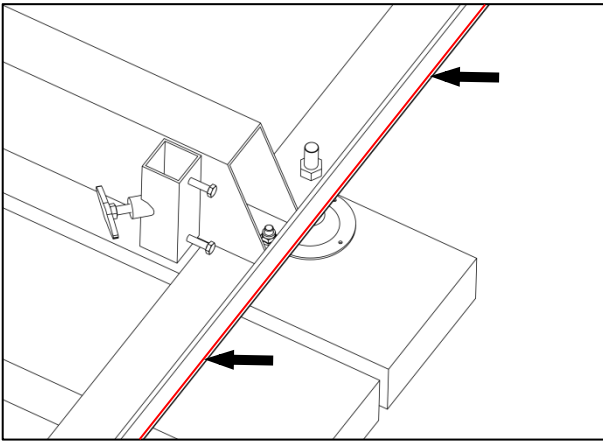

We recommend text screwing the leveling legs to sleepers once the mill has been made level. So before text screwing the mill to the sleepers, it is highly recommended that you run a string line down **both** sides of the mill, to make sure the track is straight and level. (The string line is in pink in the above picture).

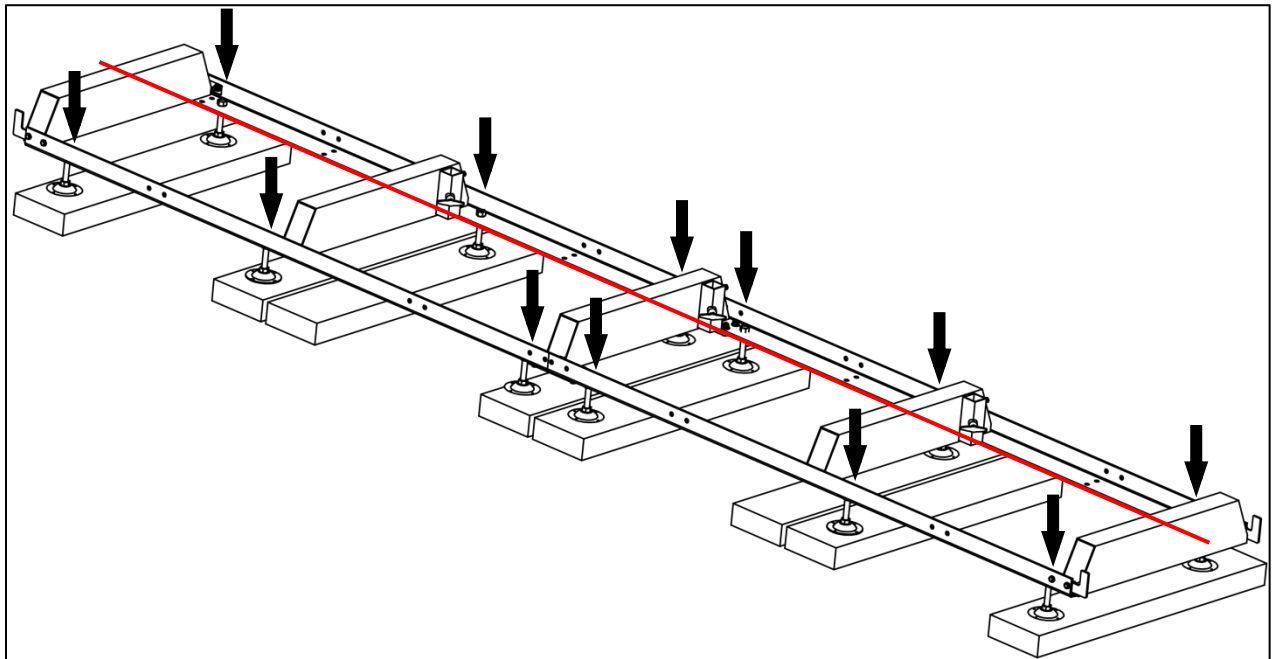

The **BLACK ARROWS** indicate where the locations of the leveling legs are. There are 4pcs per 87in. of track. 174 in. total on the machine. On the intermediate bunks the leveling legs alternate. We recommend placing the mill leveling legs on sleepers running left to right as shown above. You need to make sure the bunks are also level. To do this you use a spirit level going left to right on top of each bunk and also using a string line down the length of the track. The string line needs to be approx. 10mm **above** the bunks.

#4 – CARRIAGE ASSEMBLY

1. Place a moving blanket on the shipping pallet that the sawmill crate was strapped to. The blanket will prevent the blade guard covers from becoming scratched. Using a **minimum of two people** or a mechanical advantage system, remove the head assembly from the sawmill crate and place face down on the blanker. The head assembly is very heavy, proper technique must be used to avoid injury or damage.

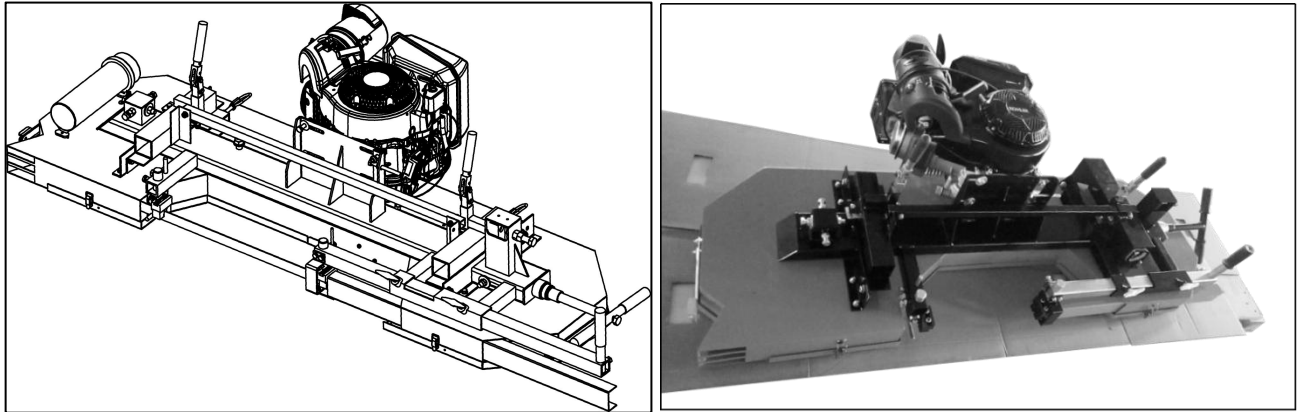

2. Lay the above carriage pieces out.

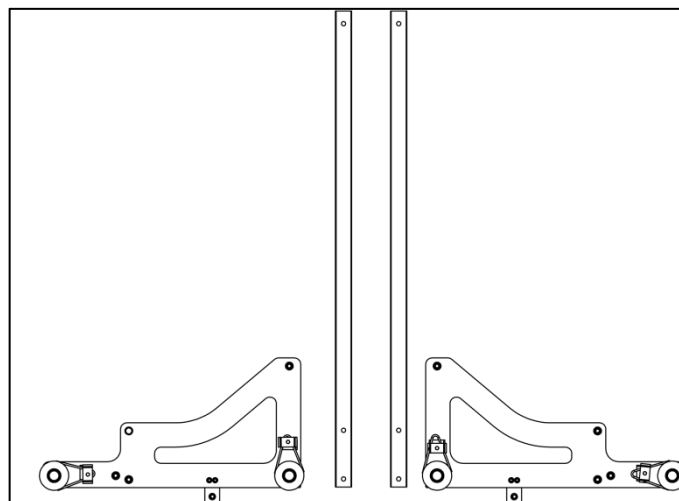

3. Then Insert vertical post assemblies into corresponding locations in head assembly.

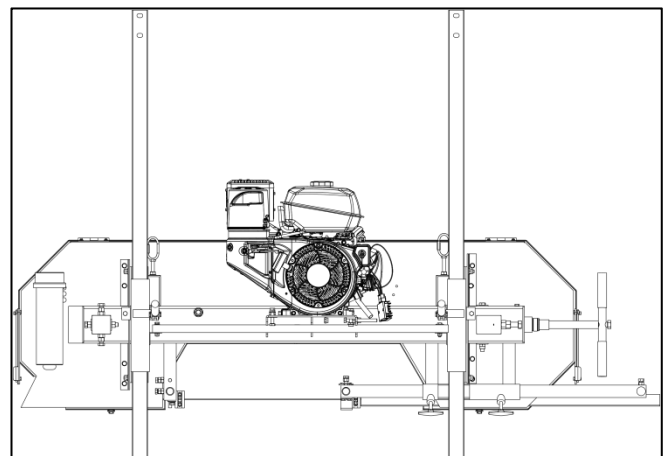
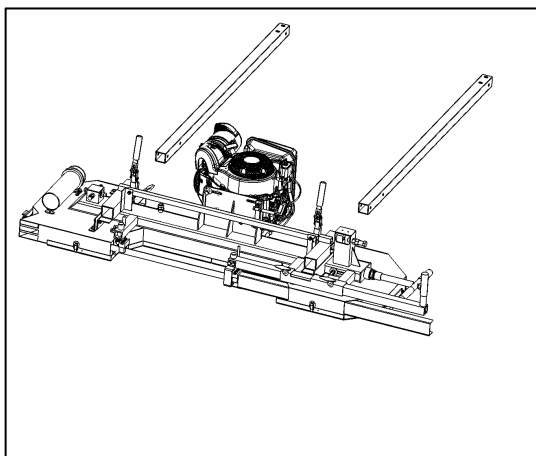

4. Assemble front vertical post to wheel assembly using the two bolts and back plate. Repeat same step for the other front vertical post assembly.

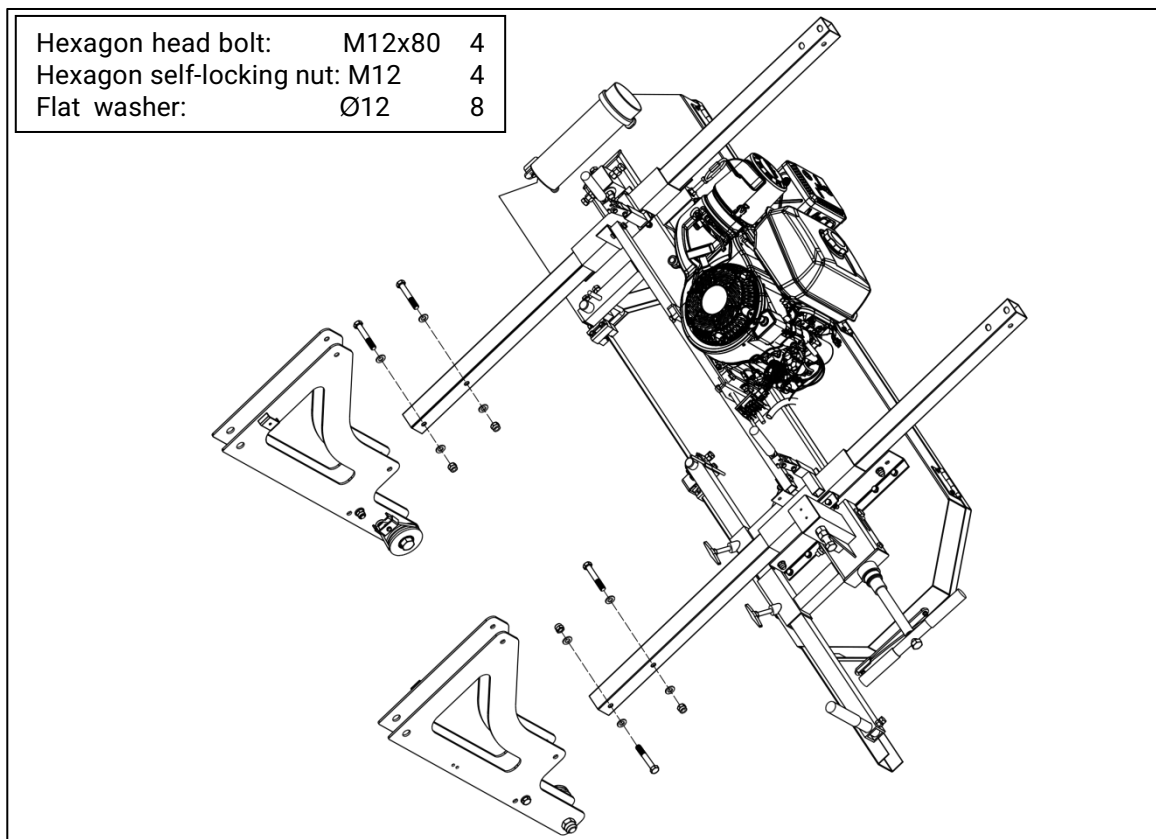

5. Assemble rear vertical post to wheel assembly using the two bolts and back plate. Repeat same step for the other rear vertical post assembly.

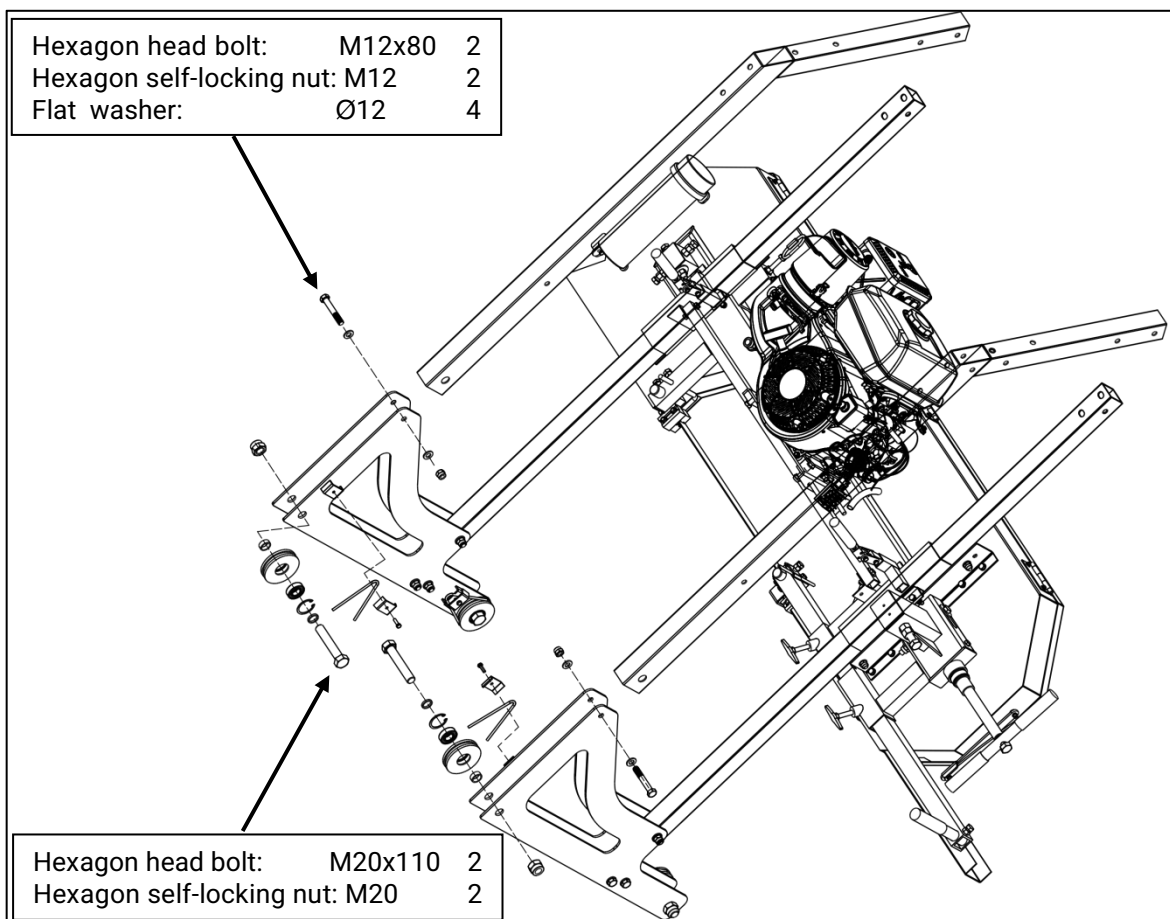

6. Lock the cam handles on both the square post to prevent the head from moving when it is stood up in the coming steps. Ensure that when activating the cam handles, the clamps securely lock on the square vertical post.

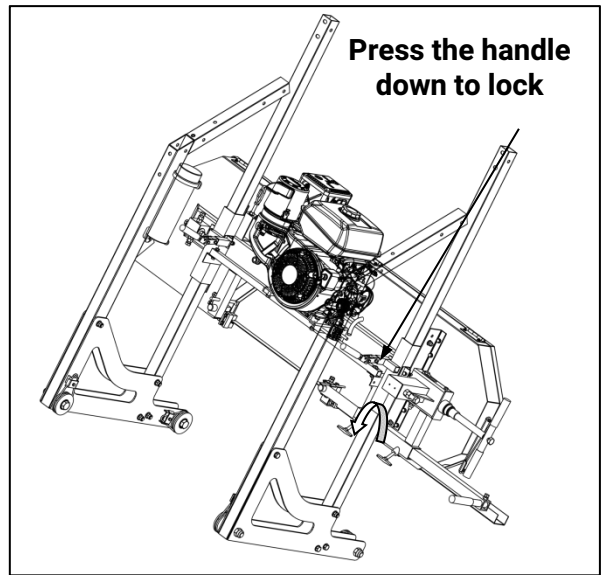
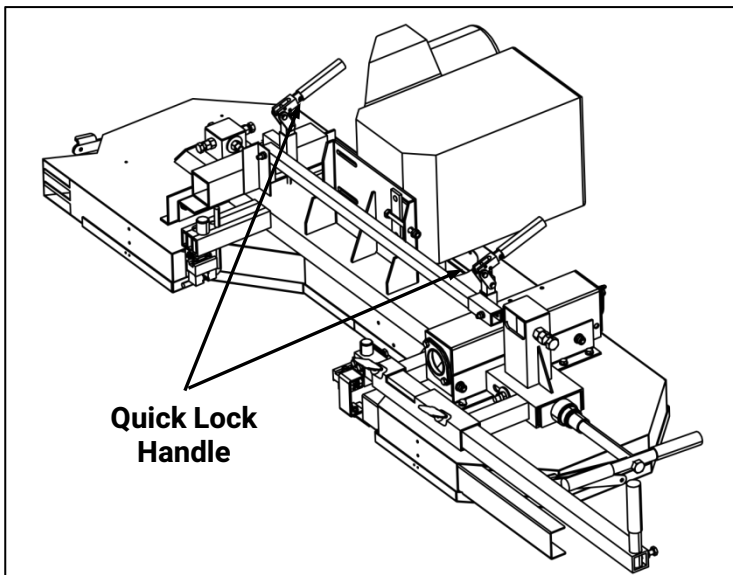

7. With one person on each post, stand the head assembly up on the wheels as shown above. Again, using a **minimum of two people**, set the saw head assembly on the track system ensuring the carriage wheel grooves rest on the "L" rails. The square vertical post should be on the same side as the log supports

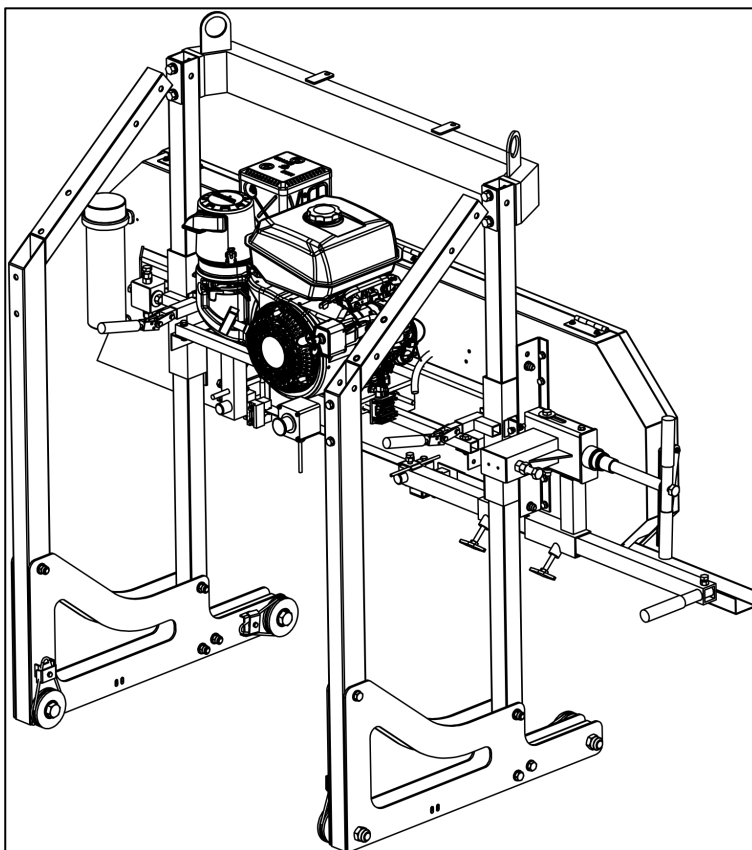

8. Slide the cross beam into the two square tube post. Bolt the top of the square tube post and the cross beam

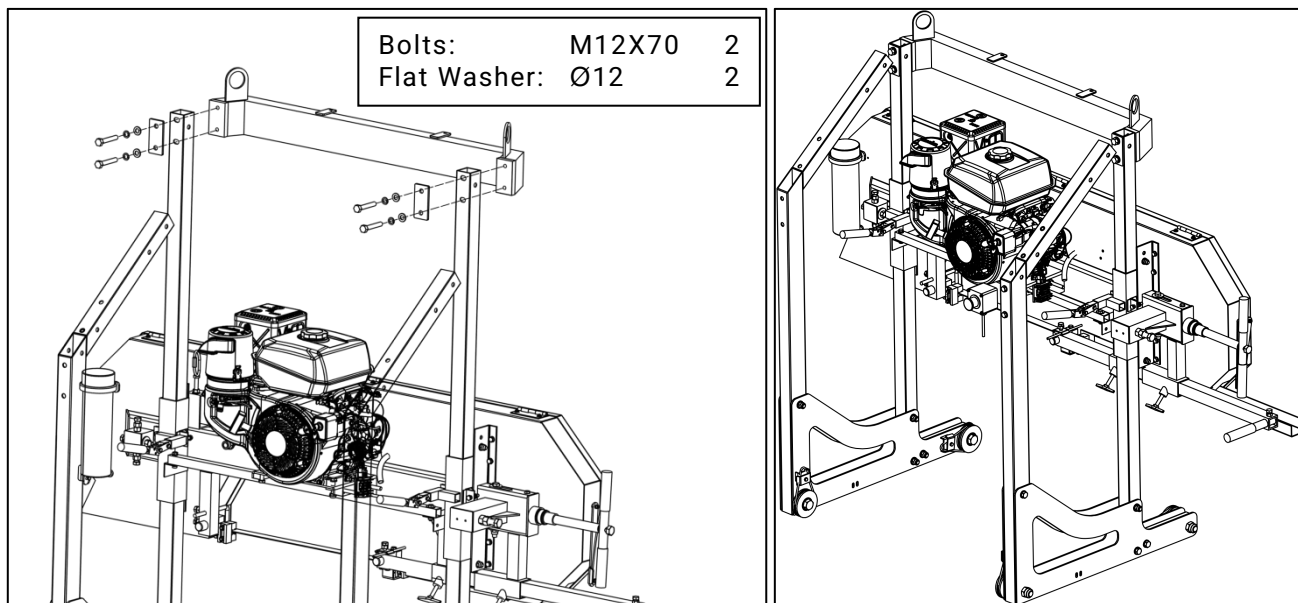

9. Install the connecting clamping plate, upper arch and steel cable roller, using wrench to hold the nut, tighten the bolt

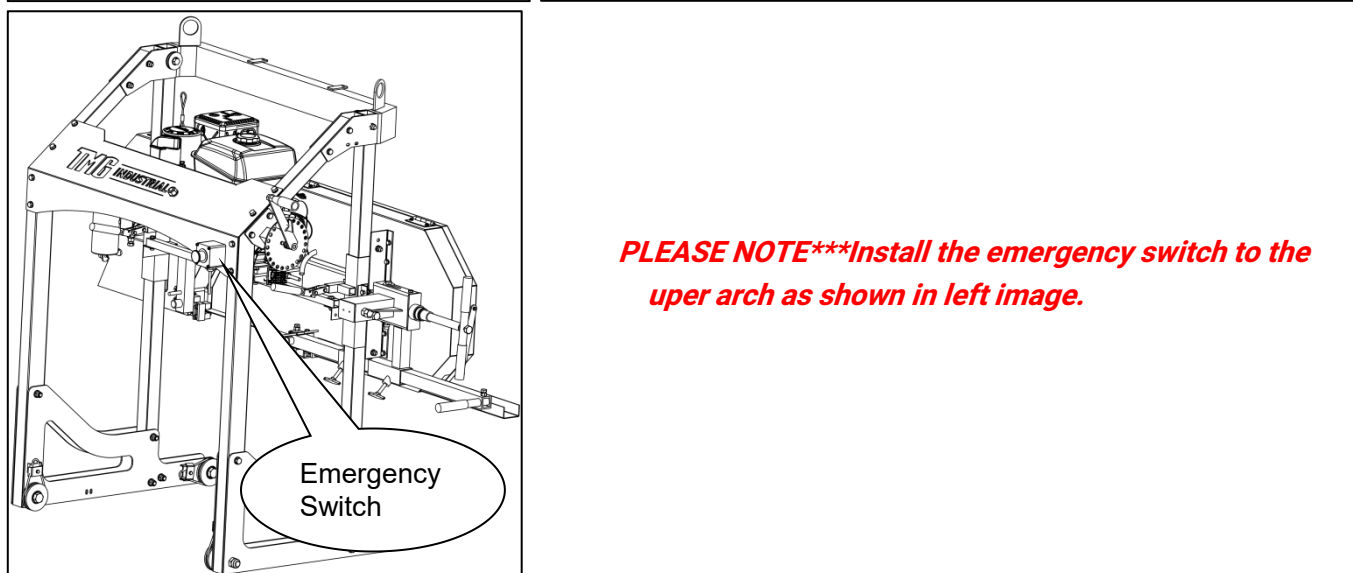
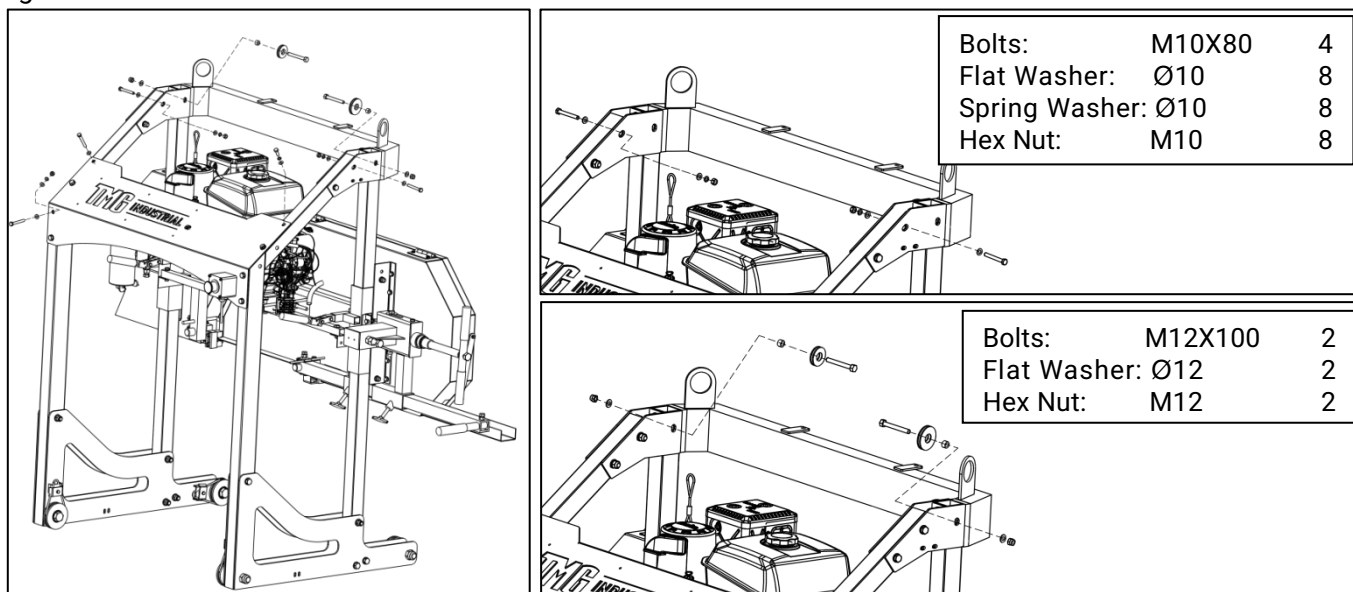

PLEASE NOTE*Install the emergency switch to the upper arch as shown in left image.**

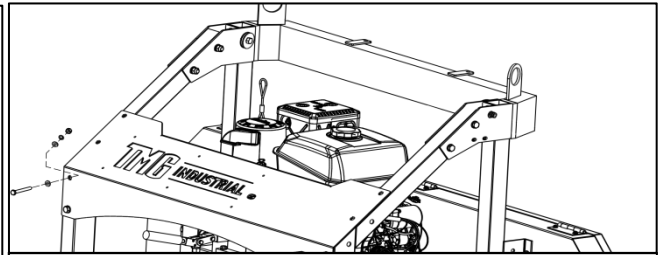
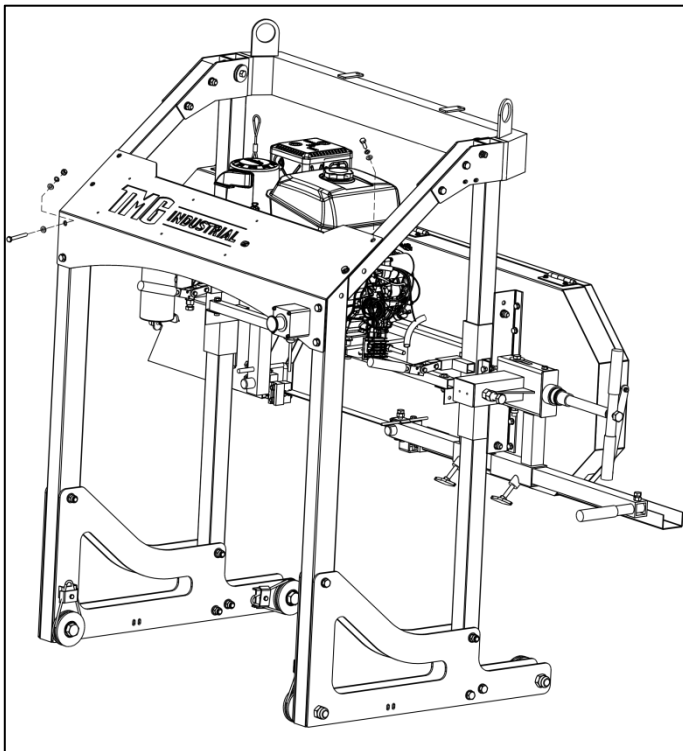

| | | |
|----------------|--------|---|
| Bolts: | M10X90 | 4 |
| Flat Washer: | Ø10 | 8 |
| Spring Washer: | Ø10 | 4 |
| Hex Nut: | M10 | 4 |

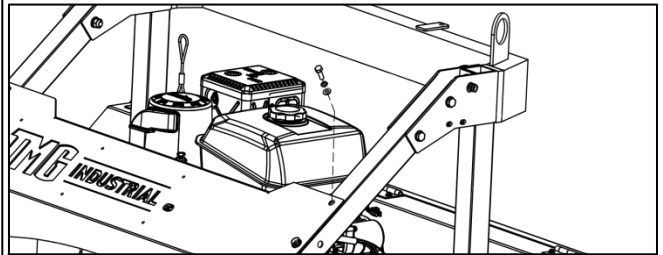

| | | |
|--------------|--------|---|
| Bolts: | M10X30 | 2 |
| Flat Washer: | Ø10 | 2 |

10. Install the lifting system, using wrench to hold the nut, tighten the bolt.

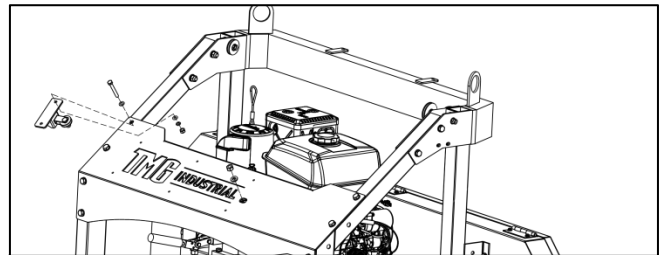
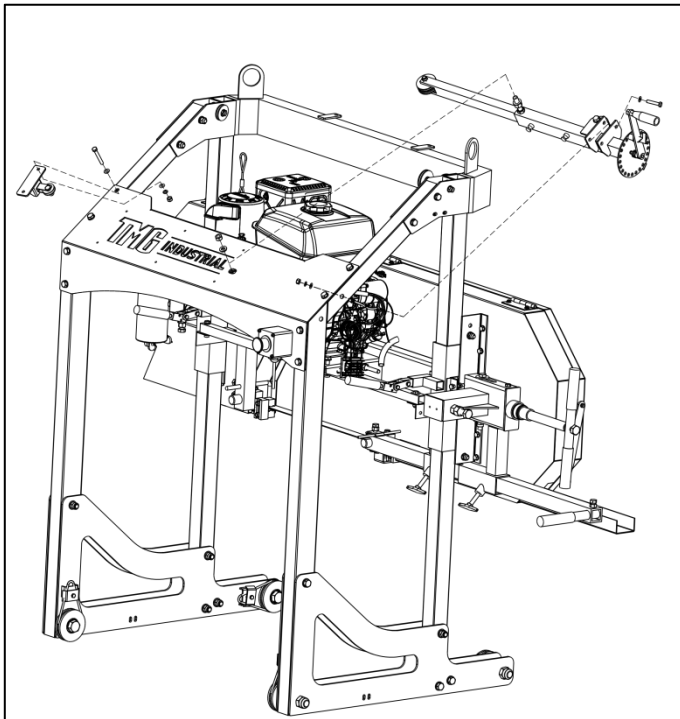

| | | |
|----------------|--------|---|
| Bolts: | M10X75 | 2 |
| Flat Washer: | Ø10 | 2 |
| Spring Washer: | Ø10 | 2 |
| Hex Nut: | M10 | 2 |

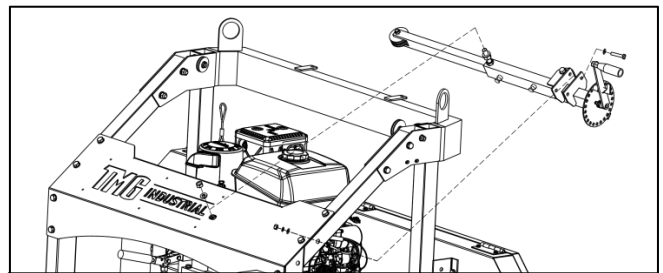

| | | |
|----------------|-----------|---|
| Bolt: | M 10 x 80 | 2 |
| Flat Washer: | Ø10 | 4 |
| Spring Washer: | Ø10 | 2 |
| Nuts: | M10 | 2 |
| Nuts: | M16 | 2 |

11. Place the measuring scale assembly, the assembly include ruler and height indicator.

A. install ruler, using wrench to hold the nut, tighten the bolt.

B. Install the square indicator rod to the sawmill using the two bolts and tighten. Slide the scale indicator over the square rod and tighten.

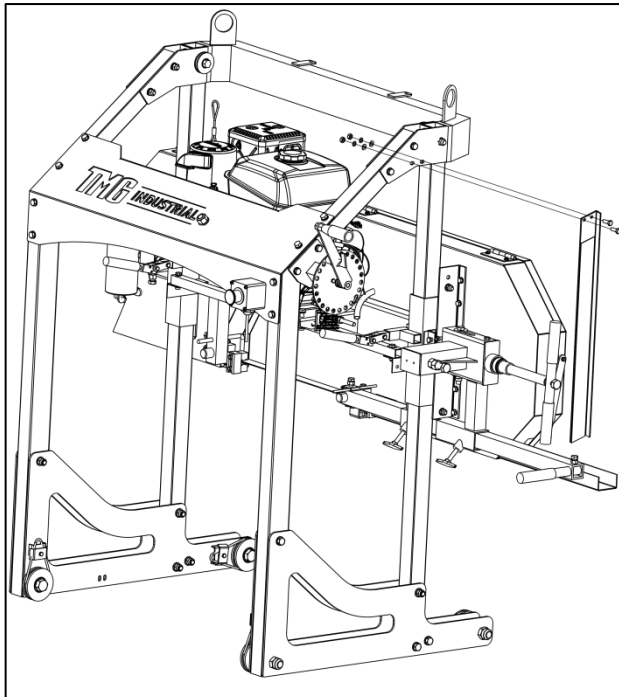

| | | |
|---------------------|-------|---|
| Hexagon Head Bolt : | M8X20 | 2 |
| Spring Washer: | Ø8 | 2 |
| Flat Washer | Ø8 | 2 |
| Nuts: | M8 | 2 |

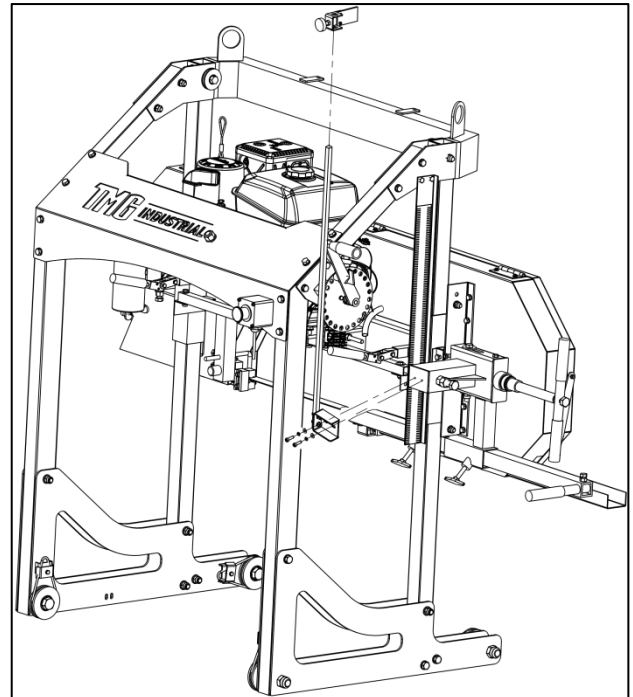

| | | |
|---------------------|-------|---|
| Hexagon Head Bolt : | M6X25 | 2 |
| Spring Washer: | Ø6 | 2 |
| Flat Washer | Ø6 | 2 |

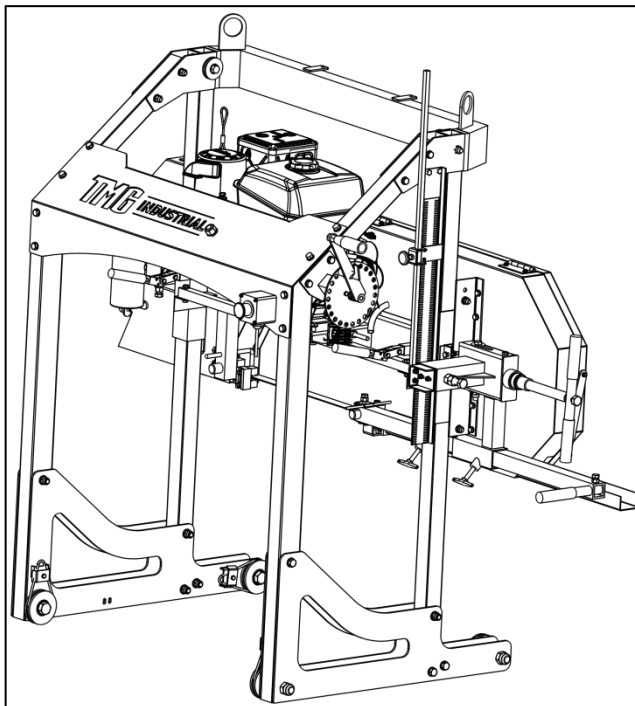

It is important to alternate tightening of the nuts (top then bottom) to ensure the black round clamp begins to compress evenly on both the top and bottom until flanges meet at outer edge.

12. Install the throttle handle to the round bar as shown in below left image. With the throttle lever in the idle position/fully open, pull the cable tight at the engine and tighten the screw to hold it in place. This will take all of the slack out of the cable.

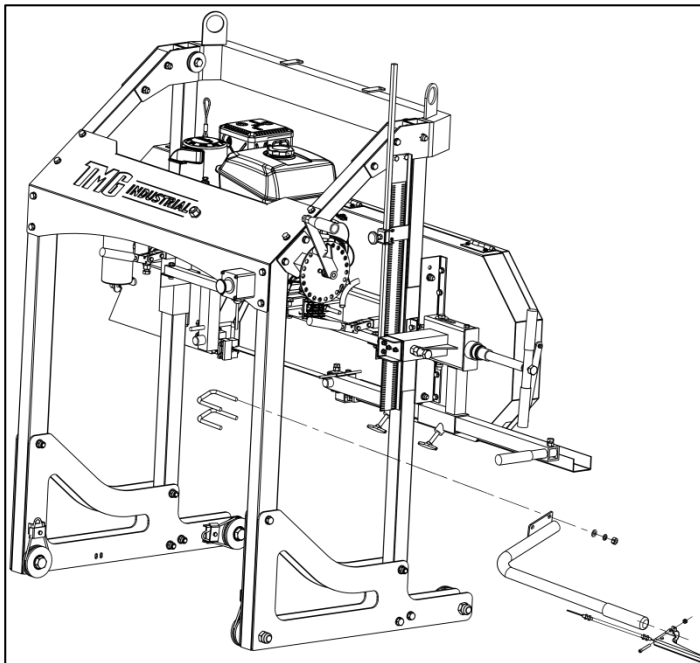

PLEASE NOTE*The idler screw needs to be wound fully out failure to do this will result in the engine not running at its full RPMs' which will result a poor cut.**

13. Install the cooling box bracket on the beam, using wrench to hold the nut, tighten the bolt.

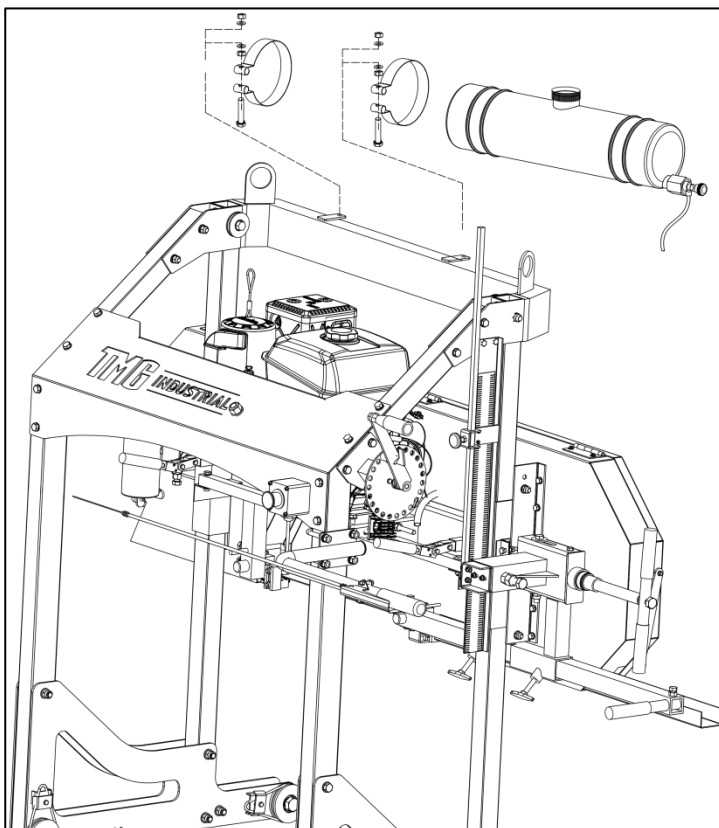

| | | |
|---------------------|---------|---|
| Hexagon Head Bolt : | M10X105 | 2 |
| Flat Washer | Ø10 | 4 |
| Nuts: | M10 | 4 |

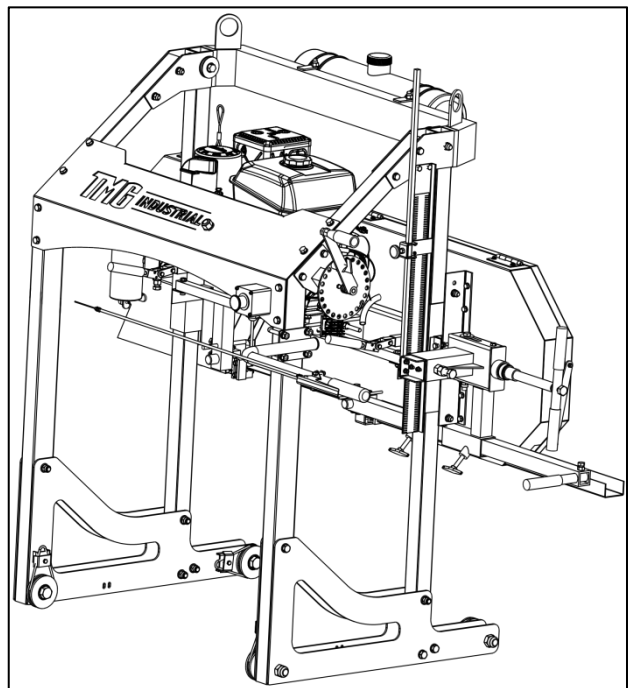

14. Install the travel locking device on the travel assembly, using wrench to hold the nut, tighten the bolt.

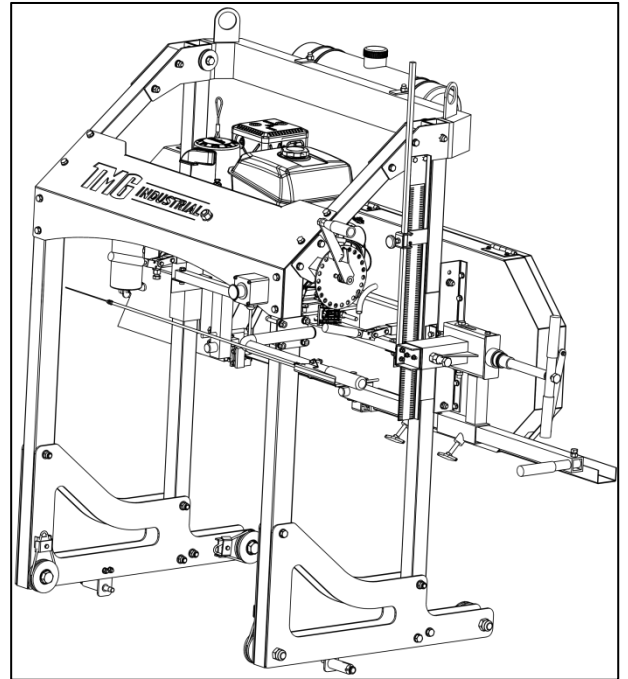
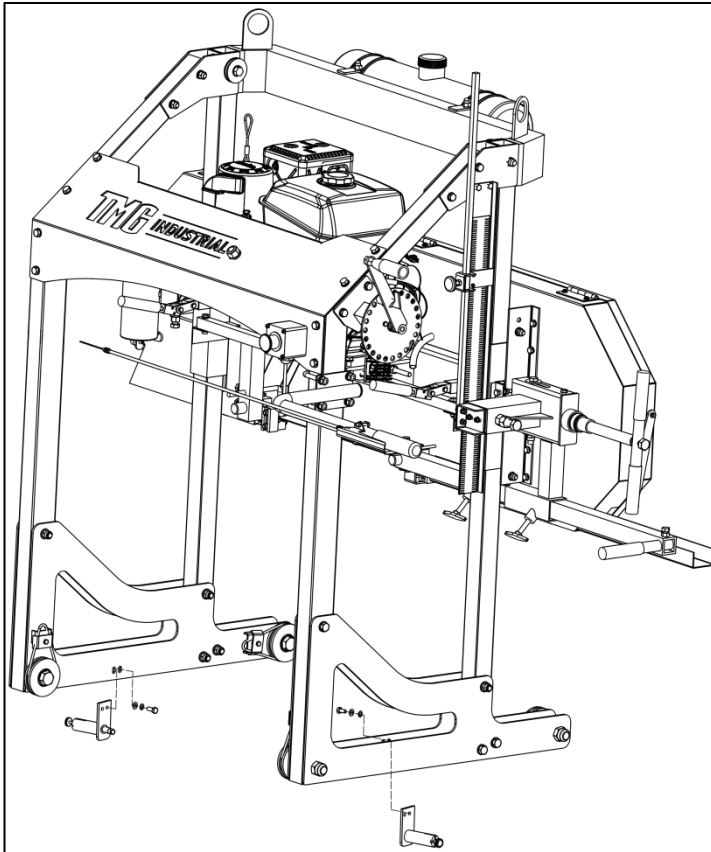

| | | |
|---------------------|-------|---|
| Hexagon Head Bolt : | M8X16 | 4 |
| Spring Washer: | Ø8 | 4 |
| Flat Washer | Ø8 | 4 |

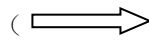
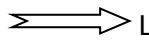

15.Route the cables on both sides as shown in the below image.

( Short cable,  Long cable)

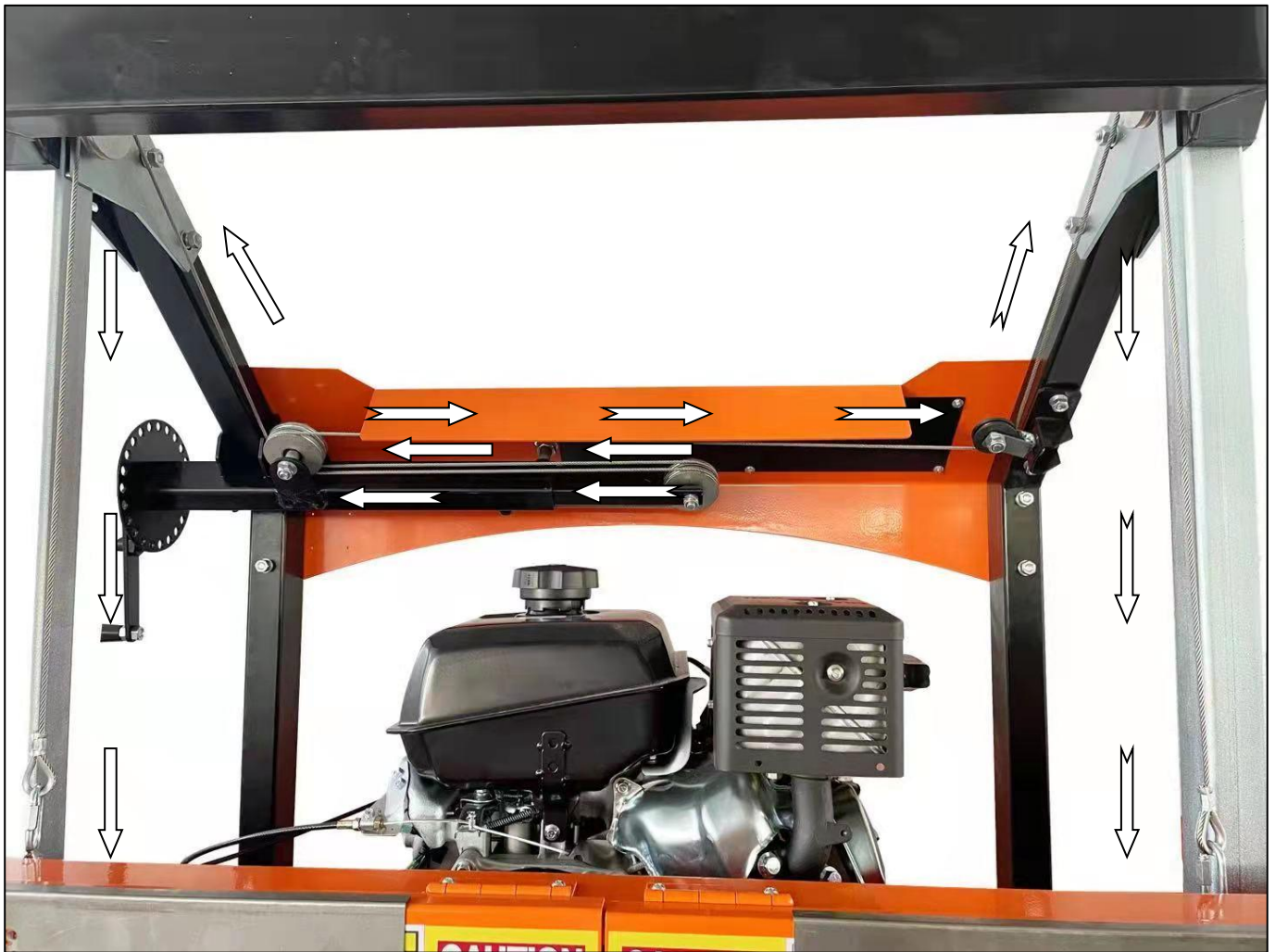

16. The transparent water pipe connects the water tank to the copper connector

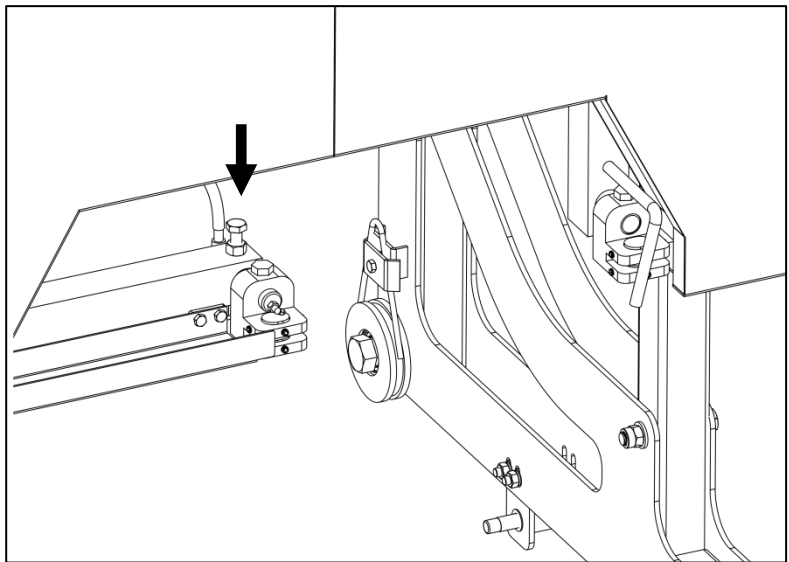

Please Note: We recommend adding some dishwashing liquid to the tank to help lubricate the wood – two to three capfuls.

17. Add waterproof grease to the threads of the blade tension "T" handle and to the washer face that it meets before use. Proper blade tension is achieved when the blade deflects no more than a total of 1/8" - 1/4" up/down.



****Note – It is very important to take the tension off of the blade by turning the "T" handle in the counter-clockwise direction when the sawmill is not in use. Failure to do so, will result in flat spots on the rubber belts. These flat spots will cause the mill to vibrate excessively during next use.****

18. Add water proof grease to all "T" handle threads on the sawmill.

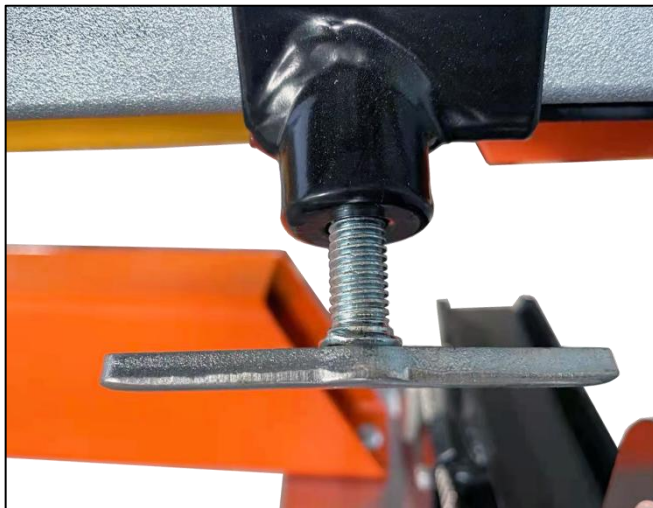

19.Push the saw head up and down the track system to ensure that the width of the track allows for the saw head to move freely. If it binds, the "L" rails will need to be set further or closer together to achieve a consistent width along the entire track system. Once the desired width is achieved, all nuts and bolts can be tightened to the log bunks .

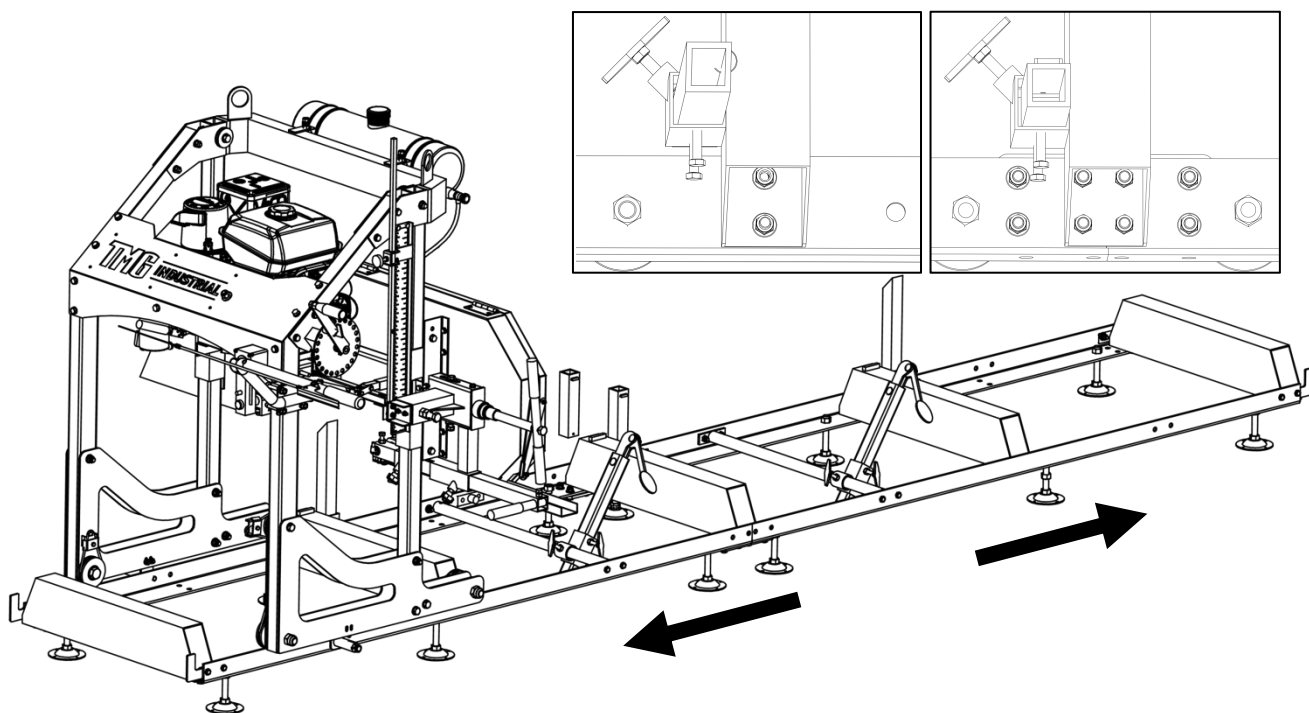

20.Using a tape measure, take a measurement from the blade to the top of the log bunk on both the left and right side. The distance should be equal on both sides. If it isn't, you will need to adjust the cable ends at the rear handle to either raise or lower one side.

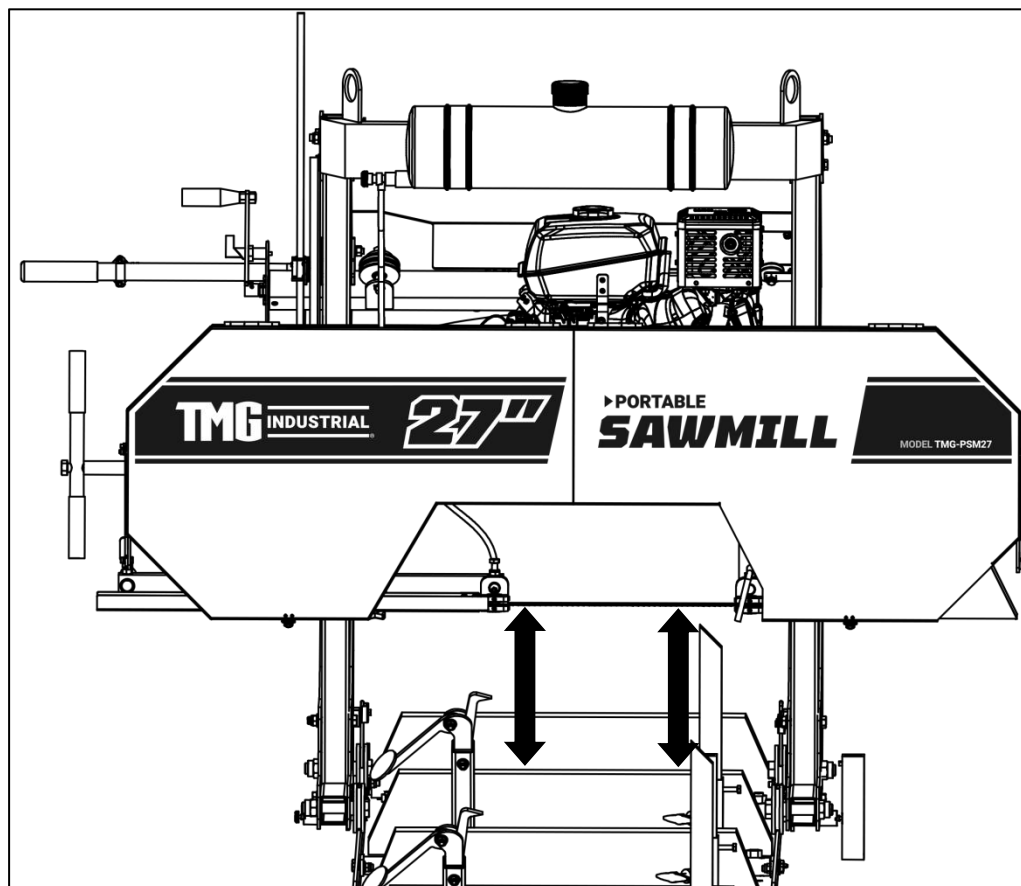

5 – ELECTRIC WIRE CONNECT

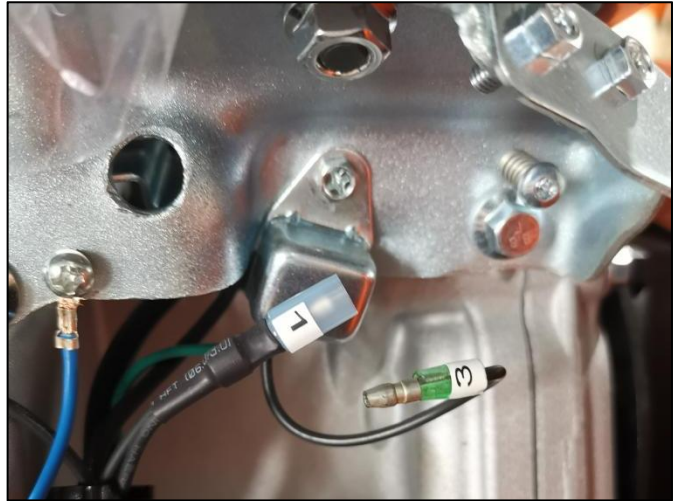

Step. 1: find the show 1 and 3 connection terminals

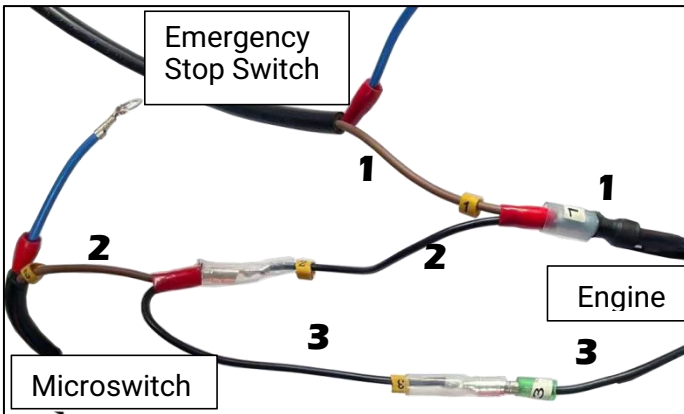

Step. 2: Disconnect the connection terminals

Step. 3: Find the **Emergency Stop Switch** and the **Microswitch**

Step. 4: Connect the 1 and 1,2 and 2,3 and 3

Step. 5: Connect the ground wire (Blue) on the engine

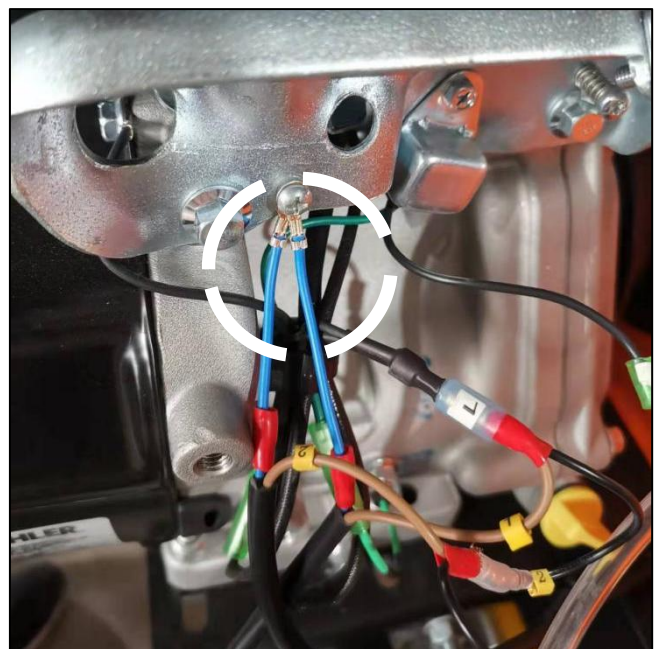

#6- ENGINE

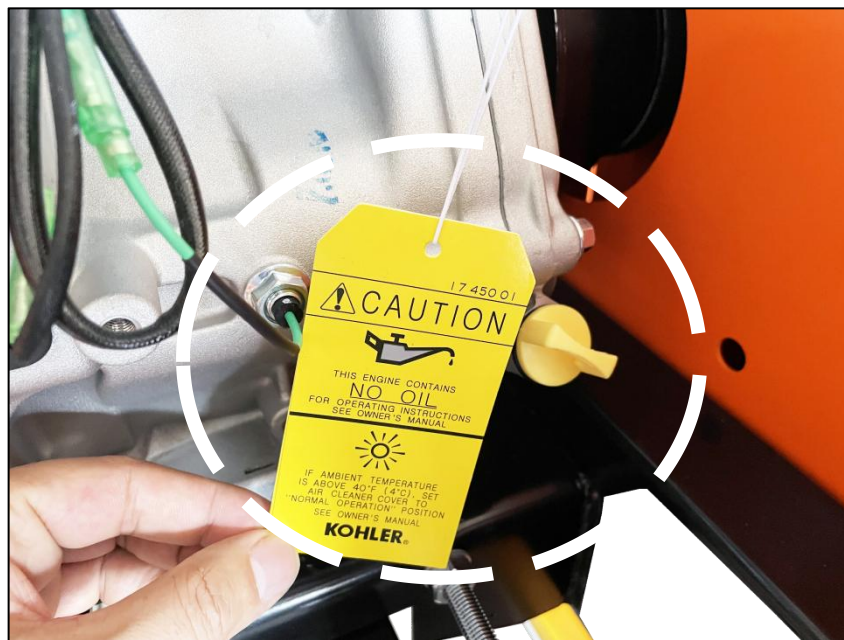

Refer to the engine manual before using your sawmill. Please note that the engine does not contain any petrol or engine oil when it is shipped. Furthermore, the engine is equipped with an oil alert system, meaning that if the crankcase oil level is low or empty, the power is cut to the spark plug and it will not start.

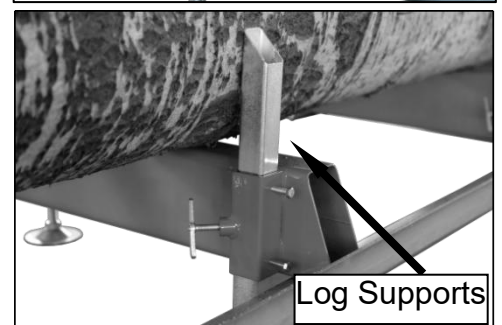
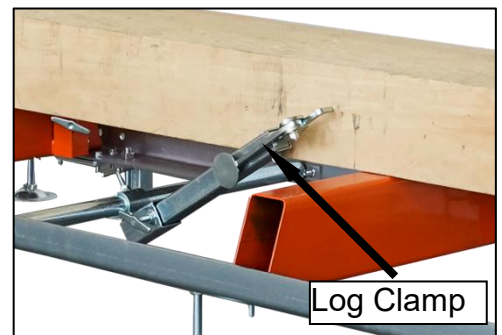
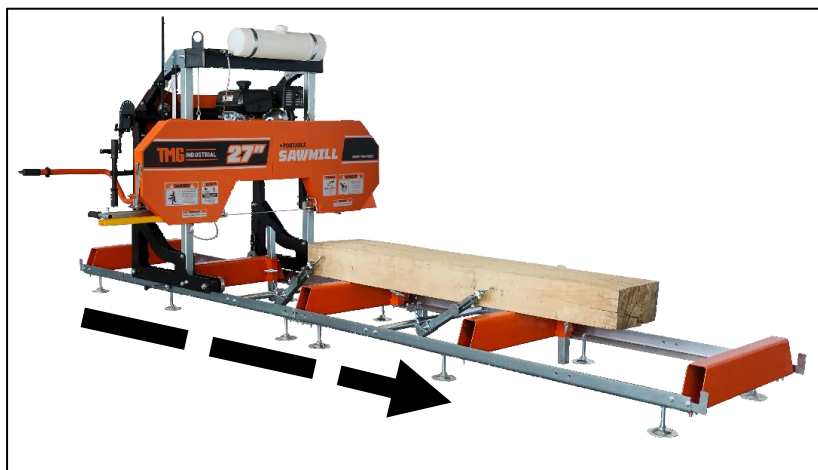

Always cut in the direction shown above. The log clamp should always be on the right side of the log and the log supports should always be on the left. Failure to cut in this direction can cause the log to come loose and possibly even cause damage or injury.

****Now that your sawmill is assembled, please run through the "SAWMILL SET-UP PROCEDURES" in the following section. Failure to do so may result in poor sawing performance, damage or injury. See next page.****

SAWMILL SET-UP PROCEDURES

#1 – BELT TENSION



To check the belt tension, with your hand, firmly try to deflect the belt up and down. There should be no more than 1/4" of deflection in both directions (1/2" total). If the belt deflects more than this, it will need to be tightened as described below.

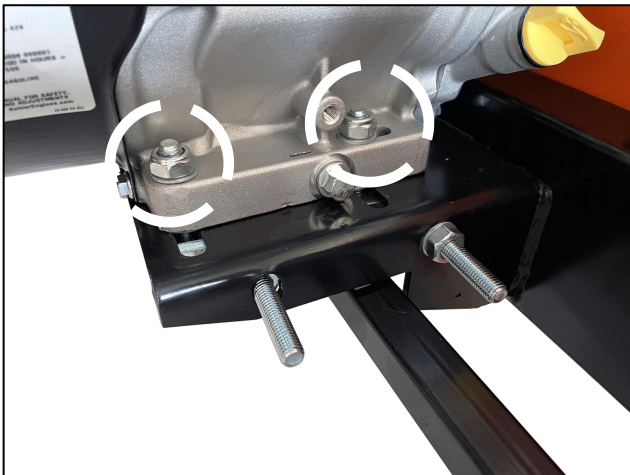

To tighten the drive belt, start by loosening the four bolts that secure the engine to the engine mount using a 16mm wrench.

Now that the engine is free to slide on the engine mounting plate, turn the 16mm nut on the horizontal stud in the clockwise direction. This will pull the engine towards the stud and apply more tension on the belt. Do this step incrementally while checking the belt for proper deflection. It is also important to ensure that the engine remains perpendicular to the drive belt. Over tightening can cause the engine to twist on the mounting plate, resulting in belt alignment issues and premature wear.

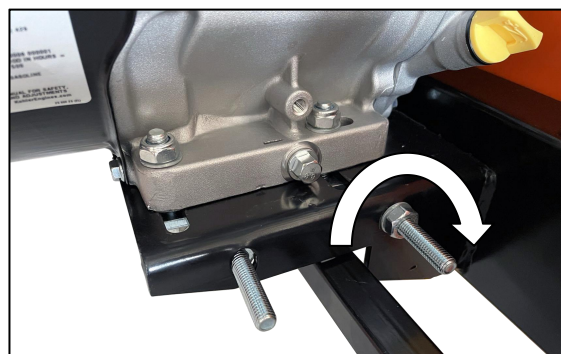

Once the desired belt tension is set, tighten the four engine bolts. *Alternatively, if the drive belt is too tight, the 16mm nut on the horizontal stud can be turned counter-clockwise.*

#2 – BLADE TRACKING

Never attempt the below with the engine running. As a safety precaution, remove the spark plug cap. It is also advised to wear gloves and safety glasses when working with the blade as it is extremely sharp.

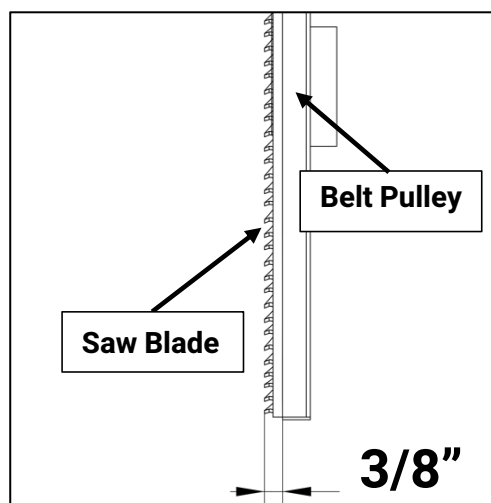
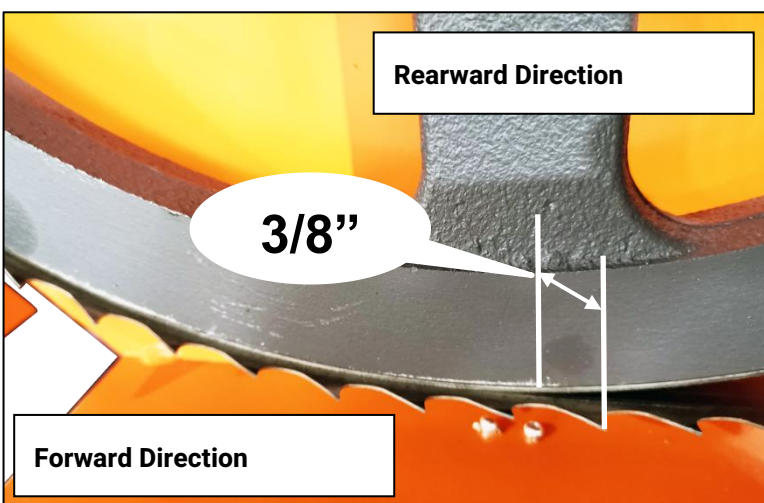

The blade should run with the same tooth to bandwheel face distance on both sides. 3/8" is ideal. Measure the distance from the tip of the blade tooth to the front face of the bandwheel on both sides. If an adjustment on either side is required, the below steps will detail this procedure.

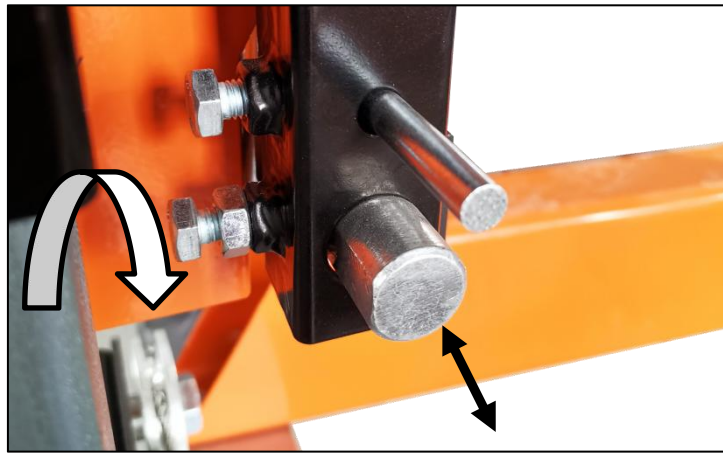

Loosen the blade guide assembly bolt with a socket. The round shaft should now be free to slide rearward and out of the way. Perform this step on both guide assemblies. This will ensure that the guide bearings do not influence tracking of the blade while adjusting.



Take some tension off of the blade by turning the "T" handle in the counter-clockwise direction one full turn from full tension position.

Adjusting The Right Hand Side



Loosen the tracking alignment locking nut with an adjustable wrench.

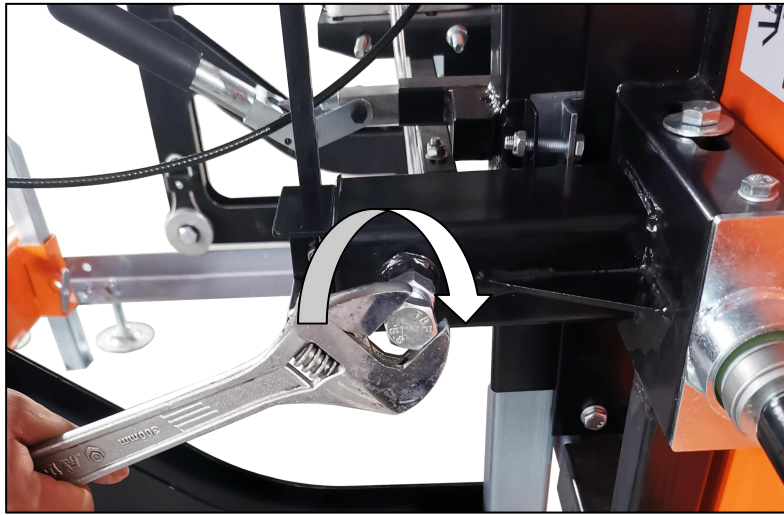

The alignment bolt can now be turned to change the angle of the bandwheel and track the blade. To move the blade more rearward on the bandwheel, this bolt will need to be turned clockwise. Alternatively, turning the bolt in the counter-clockwise direction would force the blade to run more forward on the bandwheel. Turn the bolt a 1/2 turn and re-tension the blade.

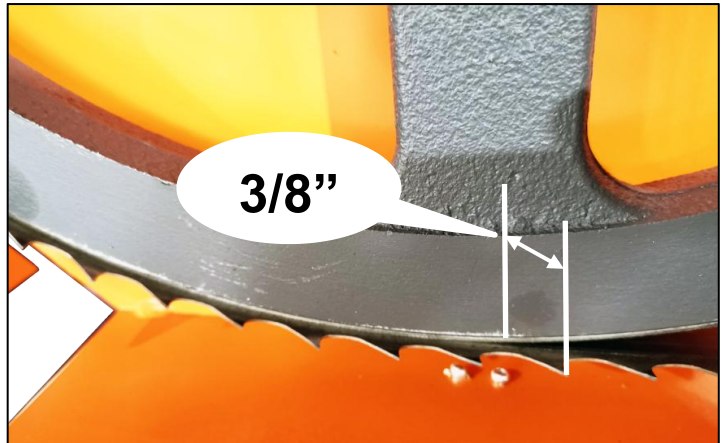

Wearing gloves, spin the bandwheel with your hand and observe how the blade has changed tracking. Measure the distance again and repeat the above step to further compensate if required. The ideal measurement is 3/8".



Once satisfied with the measurement, tighten the locking nut clockwise.

Adjusting The Left Hand Side

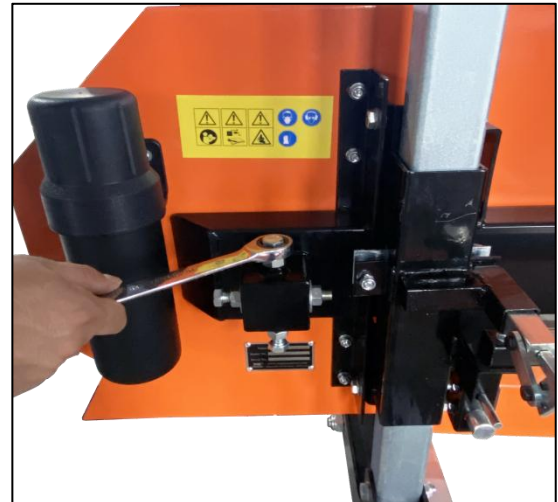
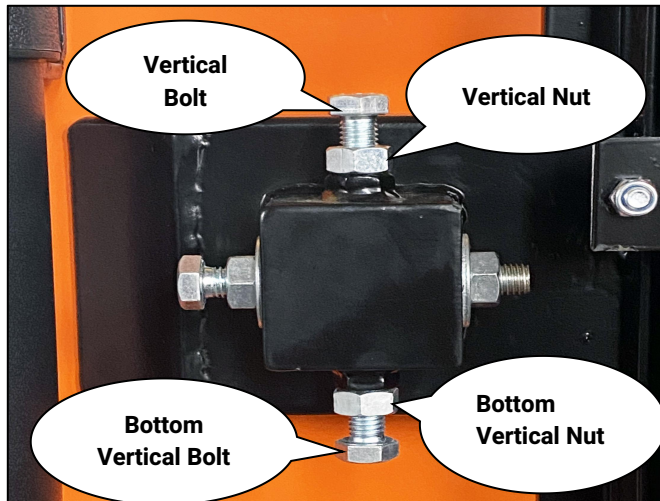

To adjust the left side of the sawmill, again start by taking the tension off of the blade by turning the "T" handle one turn in the counter-clockwise direction. Using a 16mm wrench, loosen the "**vertical nut**" a ½ turn. Do the same on the "**bottom vertical nut**". Next, loosen both "**vertical bolts**" a ½ turn. This will take the clamping force off of the bandwheel shaft caused by these two bolts and allow it to move freely in the following steps.

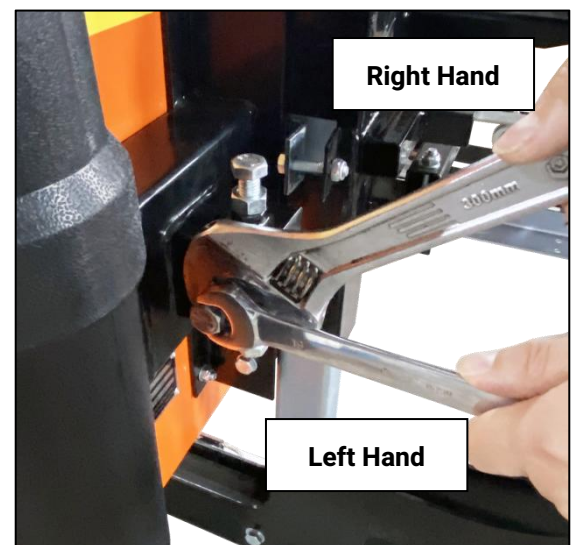
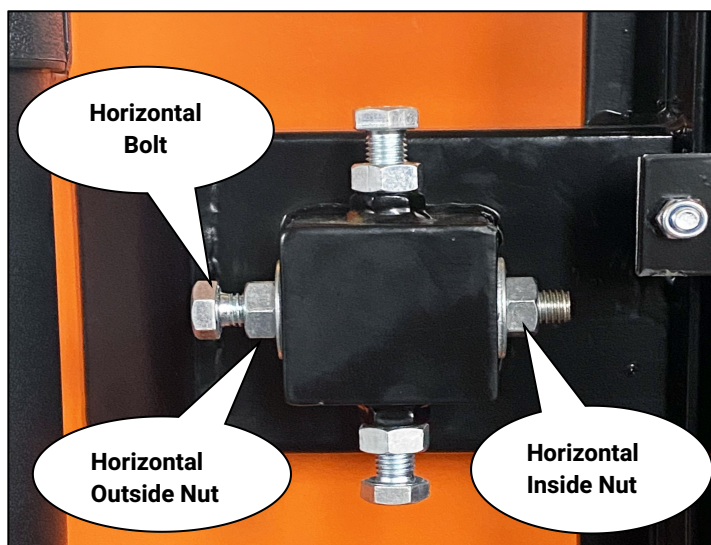

Moving The Blade Forward

Using a 16mm wrench, hold the "**horizontal bolt**" stationary with a wrench and turn the "**horizontal inside nut**" counter-clockwise a ½ turn. Still holding the "**horizontal bolt**" stationary, turn the "**horizontal outside nut**" clockwise a ½ turn. This has now shifted the "**horizontal bolt**" and bandwheel shaft, causing the blade to track more forward.

Moving The Blade Rearward

Using a 16mm wrench, hold the **“horizontal bolt”** stationary with a wrench and turn the **“horizontal outside nut”** counter-clockwise a ½ turn. Still holding the **“horizontal bolt”** stationary, turn the **“horizontal inside nut”** clockwise a ½ turn. This step has now shifted the **“horizontal bolt”** and bandwheel shaft, causing the blade to track more forward.

Tighten the vertical bolts, then nuts to clamp the bandwheel shaft back into vertical position.

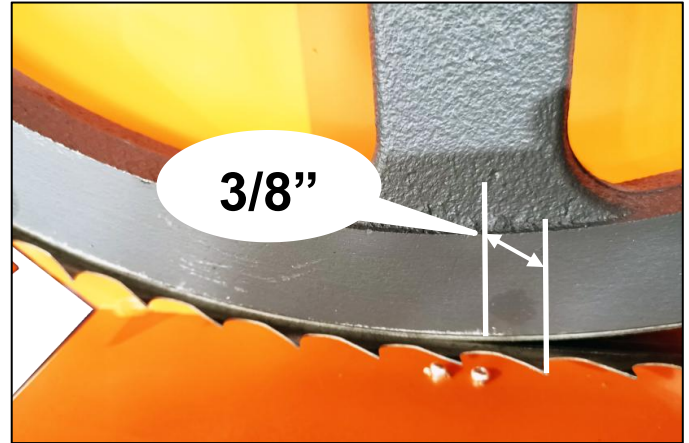
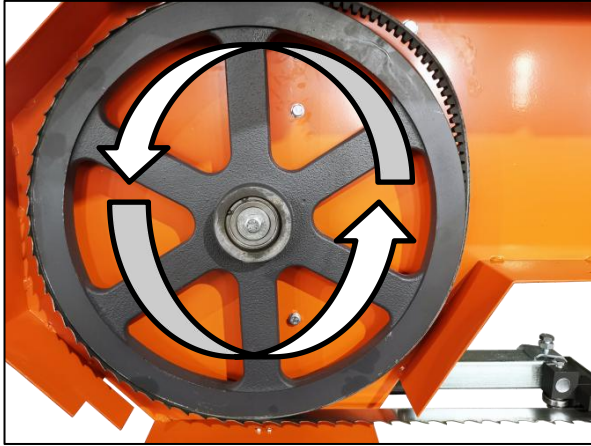

Re-tension the blade by turning the “T” handle a full turn in the clockwise direction. Wearing gloves, spin the bandwheel with your hand and observe how the blade has changed tracking.

Measure the distance again and repeat the above step to further compensate if required. The ideal measurement is 3/8”.

Once the blade is tracking true, bring the blade guide assemblies back up to the blade. Keep a paper width distance between the blade guide bearing and the back of the blade. More information on this set up can be found in the next section – **“BLADE GUIDE ADJUSTMENT”**

#3 – BLADE GUIDE ADJUSTMENT

Never attempt the below with the engine running. As a safety precaution, remove the spark plug cap. It is also advised to confirm that the blade is tracking properly before performing the below. Blade tracking is covered in the previous page.

Using a 6mm allen key, loosen the blade guide blocks on both the left and right sides. They should be free to slide up and down.

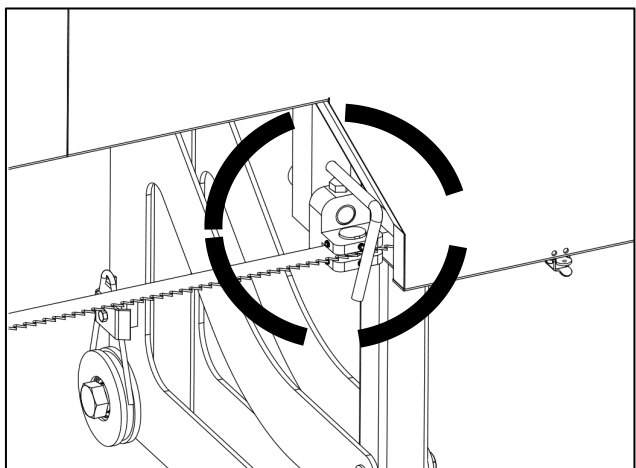

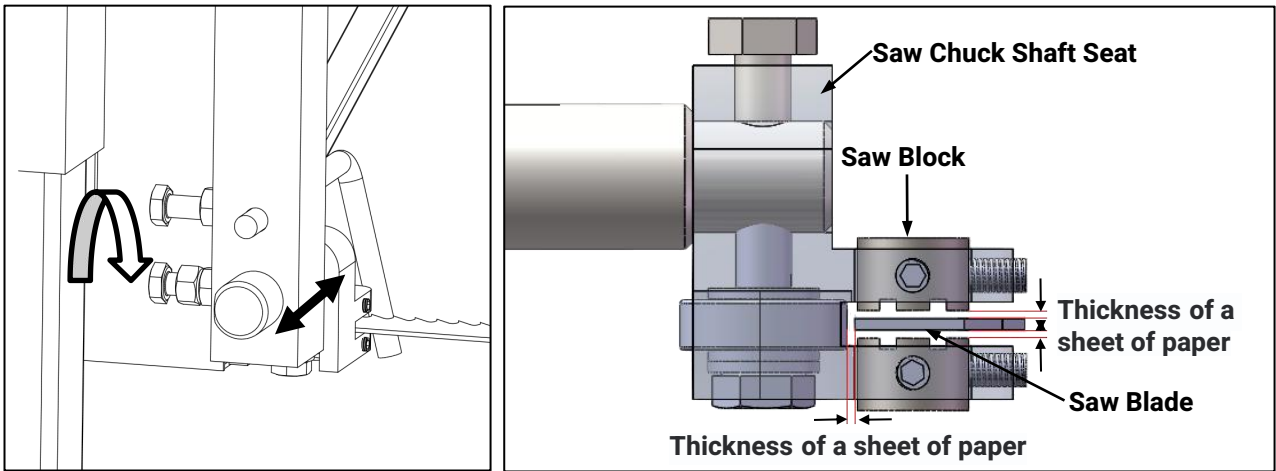

Loosen the blade guide assembly bolt with a 16mm socket. The round shaft should now be free to slide back and forth. Position it so that there is a paper width gap between the bearing and the back of blade. Tighten bolt against the flat on the shaft to secure assembly back in position.

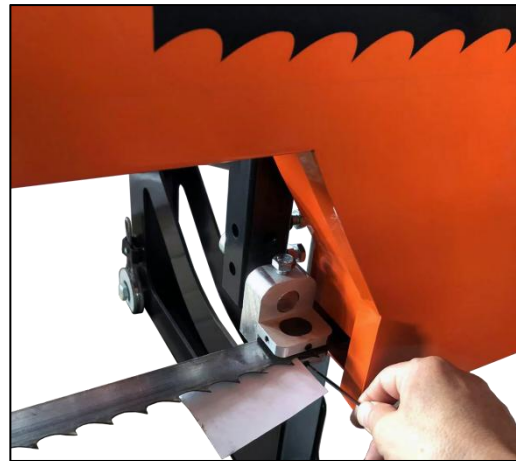

Using a piece of paper in between the blade and blade guide blocks, tighten the allen key bolts.

#4 – BLADE TENSION

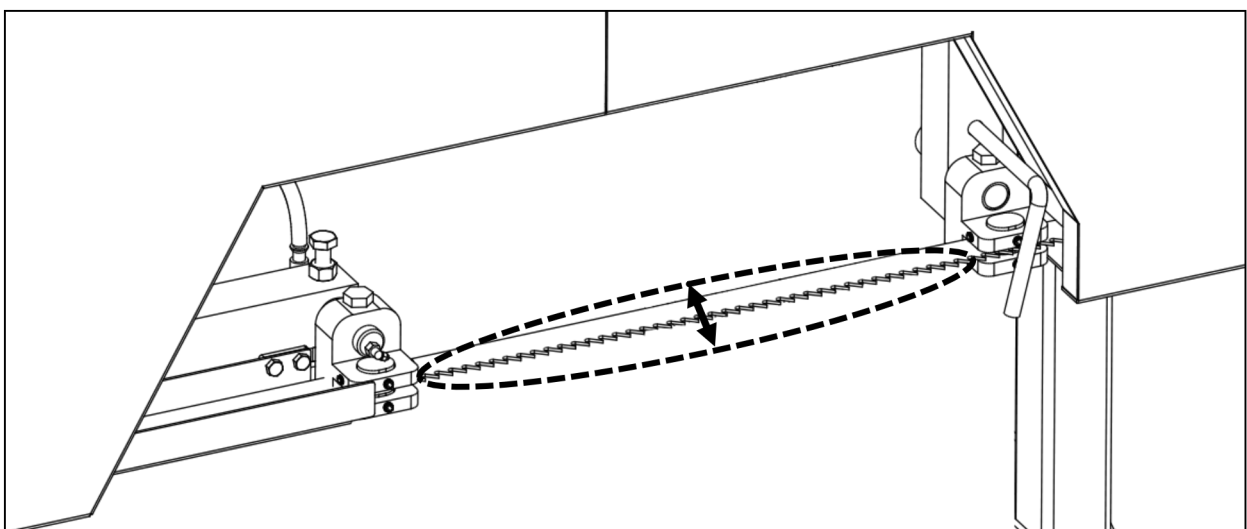

Proper blade tension is achieved when the blade deflects no more than a total of 1/8" - 1/4" up/down when it is firmly moved by hand at the center location of the blade guide blocks. Turning the blade tension "T" handle in the clockwise direction will add tension to blade.



When tensioning the blade, make sure the tracking adjustment bolt sitting behind the T handle (pictured) is sitting back in its recess after you have finished and *before* the mill is run. Failure to do this will result in the blade being thrown and possibly broken.

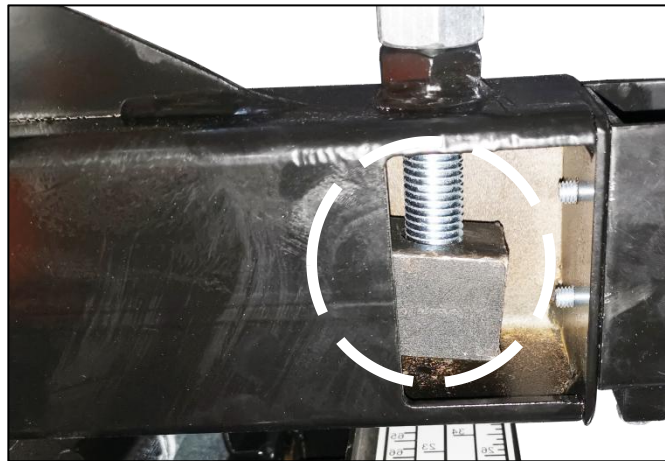

Tracking adjustment bolt out of recess, of it looks like this DO NOT start the mill until it is resting back in its recess

Tracking adjustment bolt sitting in recess. It should look like this *before* the mill is started back up.

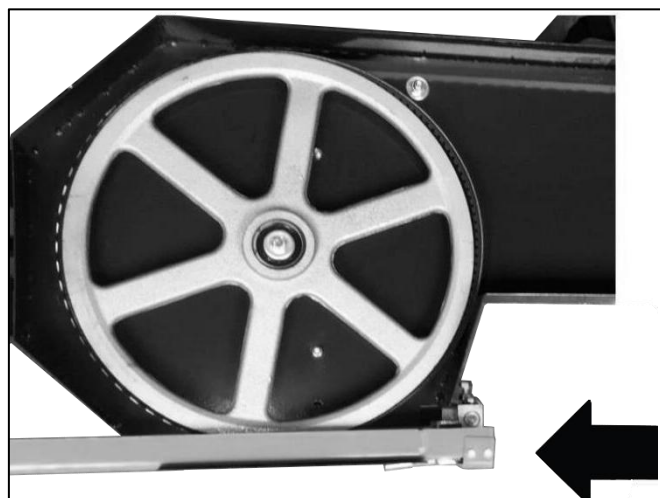

Ensure the blade support arm is locked into place after tensioning the blade.

SAWMILL MAINTENANCE

#1 – CHANGING THE BLADE

Never attempt the below with the engine running. As a safety precaution, remove the spark plug cap. Gloves and safety glasses must be worn when changing the blade.



Remove the tension in the blade by turning the “T” handle in the counter-clockwise direction and then open the blade guard cover. The blade should now be loose and free to pull straight out the front. The new blade can now be installed, guards closed and proper blade tension set.

#2 – REPLACING BELTS

Never attempt the below with the engine running. As a safety precaution, remove the spark plug cap. Gloves and safety glasses must be worn when replacing the belts.



There are two rubber “V” belts on the sawmill and they should be replaced as a set. It is not advised to replace individual belts separately. It is recommended to use a BX2007 Li drive belt for the drive side and a BX1473 Li follower belt.



Remove the tension in the blade by turning the “T” handle in the counter-clockwise direction and then open the blade guard cover. The blade should now be loose and free to pull straight out the front.

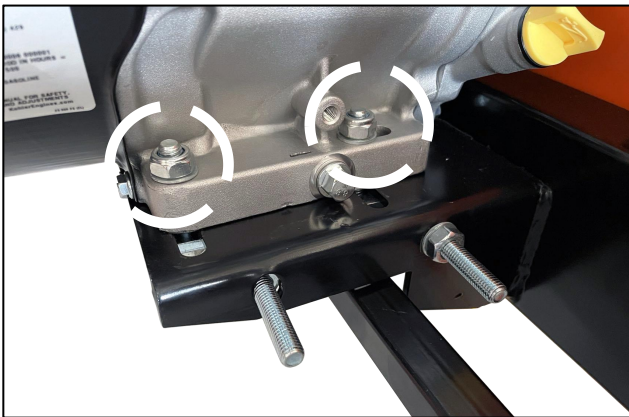

To change the drive side belt, loosen the four bolts that secure the engine to the engine mount using a 16mm wrench.

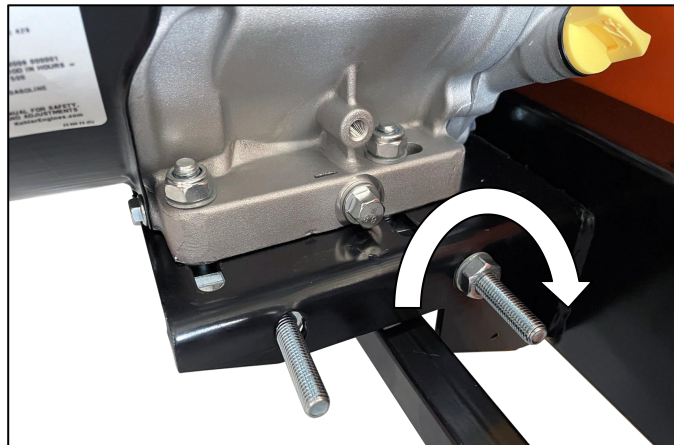

Now that the engine is free to slide on the engine mounting plate, turn the 16mm nut on the horizontal stud in the counter-clockwise direction. This will allow the engine to move and will also take the tension off of the belt. The old belt can be removed and the new belt can be installed.

Tension the new belt and refer to the ***BELT TENSION*** instructions described in the sawmill set up section of the manual.

The follower belt can now be changed by simply pulling it off and installing the new one. The blade can now be re-installed, guards closed and proper blade tension set.

****Note that blade tracking is likely to change and need adjusting when new belts are installed.***

Refer to “BLADE TRACKING” for more information.*

TROUBLESHOOTING

| Problem/Issue | Possible Causes | Resolution Options |
|--|---|--|
| Producing wavy cuts. | <ol style="list-style-type: none"> 1. Inadequate blade tension. 2. Improper blade guide set up. 3. Improper blade tracking. 4. Sap build up on blade. 5. Dull blade. 6. Pushing mill too quickly. | <ol style="list-style-type: none"> 1. Tighten blade. Refer to page 32. 2. Gap between guide blocks and blade are incorrect. Refer to page 31. 3. Adjust blade tracking. Refer to page 27. 4. Install new blade. Refer to page 34. Always use blade lubricant. 5. Install new blade. Refer to page 34. 6. Slow feed rate down and push head slower through log. |
| Last board is tapered or narrow in middle. | <ol style="list-style-type: none"> 1. Tracks are not level. | <ol style="list-style-type: none"> 1. Tracks need to be checked with level and adjusted to be square. They also need to be set up on firm, sturdy round/base so deflection does not occur from logs or sawmill head. |
| Blade dulls quickly. | <ol style="list-style-type: none"> 1. Logs are not clean. 2. Foreign objects in log. | <ol style="list-style-type: none"> 1. Logs may contain dirt/sand causing them to wear prematurely. 2. Tree may contain nails, staples, old fencing etc. |
| Blade comes off of bandwheels. | <ol style="list-style-type: none"> 1. Inadequate blade tension. 2. Improper blade guide set up. 3. Improper blade tracking. 4. Belts are worn. 5. Dull blade. 6. Pushing mill too quickly. | <ol style="list-style-type: none"> 1. Tighten blade. Refer to page 32. 2. Gap between guide blocks and blade are incorrect. Refer to page 31. 3. Adjust blade tracking. Refer to page 27. 4. Install new belts. Refer to page 34. 5. Install new blade. Refer to page 34. 6. Slow feed rate down and push head slower through log. |
| Blades are breaking. | <ol style="list-style-type: none"> 1. Too many blade sharpening. 2. Inadequate blade tension. 3. Improper blade guide set up. 4. Improper blade tracking. 5. Pushing mill too quickly. | <ol style="list-style-type: none"> 1. Replace blade. Refer to page 34. 2. Binding between guide blocks when blade is too loose. Tighten blade. Refer to page 33. 3. Gap between guide blocks and blade are incorrect. Refer to page 31. 4. Adjust blade tracking. Refer to page 27. 5. Slow feed rate down and push head slower through log. |

| | | |
|---|---|---|
| Blade is slowing down or stopping when milling. | <ol style="list-style-type: none"> 1. Inadequate blade tension. 2. Improper drive belt tension. 3. Pushing mill too quickly. | <ol style="list-style-type: none"> 1. Tighten blade. Refer to page 32. 2. Belts are worn or too loose. Replace. Refer to page 35. 3. Slow feed rate down and push head slower through log. |
| Mill is not cutting/cutting very slowly. | <ol style="list-style-type: none"> 1. Dull blade. 2. Blade is on backwards. | <ol style="list-style-type: none"> 1. Install new blade. Refer to page 34. 2. Remove blade and flip it inside out. The teeth should be facing in the direction of the log supports. |
| Mill is vibrating excessively. | <ol style="list-style-type: none"> 1. Log is not clamped securely. 2. Belts are deformed. 3. Bandwheel bearing issue. 4. Pushing mill too quickly. 5. Loose bolts. | <ol style="list-style-type: none"> 1. Ensure log is clamped firmly resting on log bunks and against log supports. 2. Belts may have flats in them from leaving blade tension tight when not in use. Replace them. Refer to page 34. 3. Inspect and replace the bandwheel bearings if worn. 4. Slow feed rate down when milling. 5. Check all bolts to ensure they are tight. |

DIAGRAM--ENSEMBLE

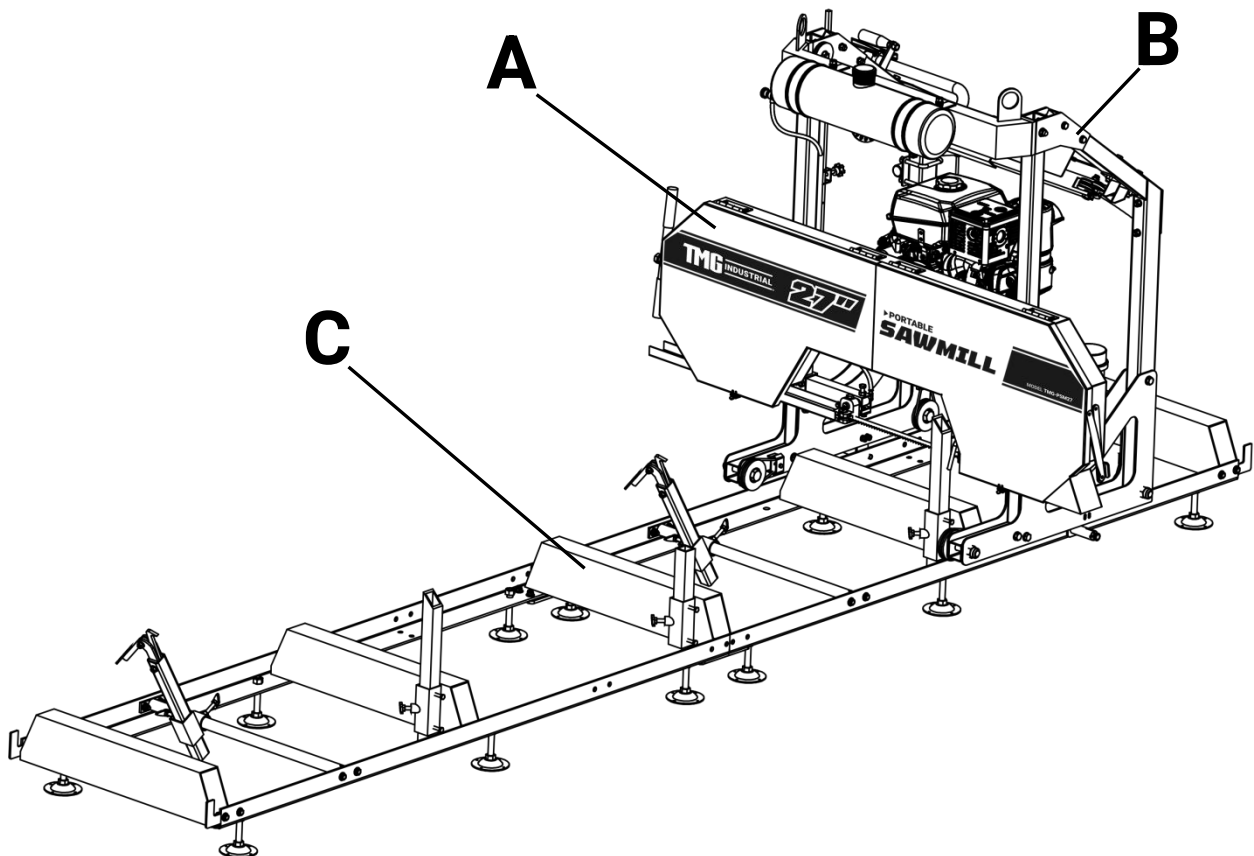
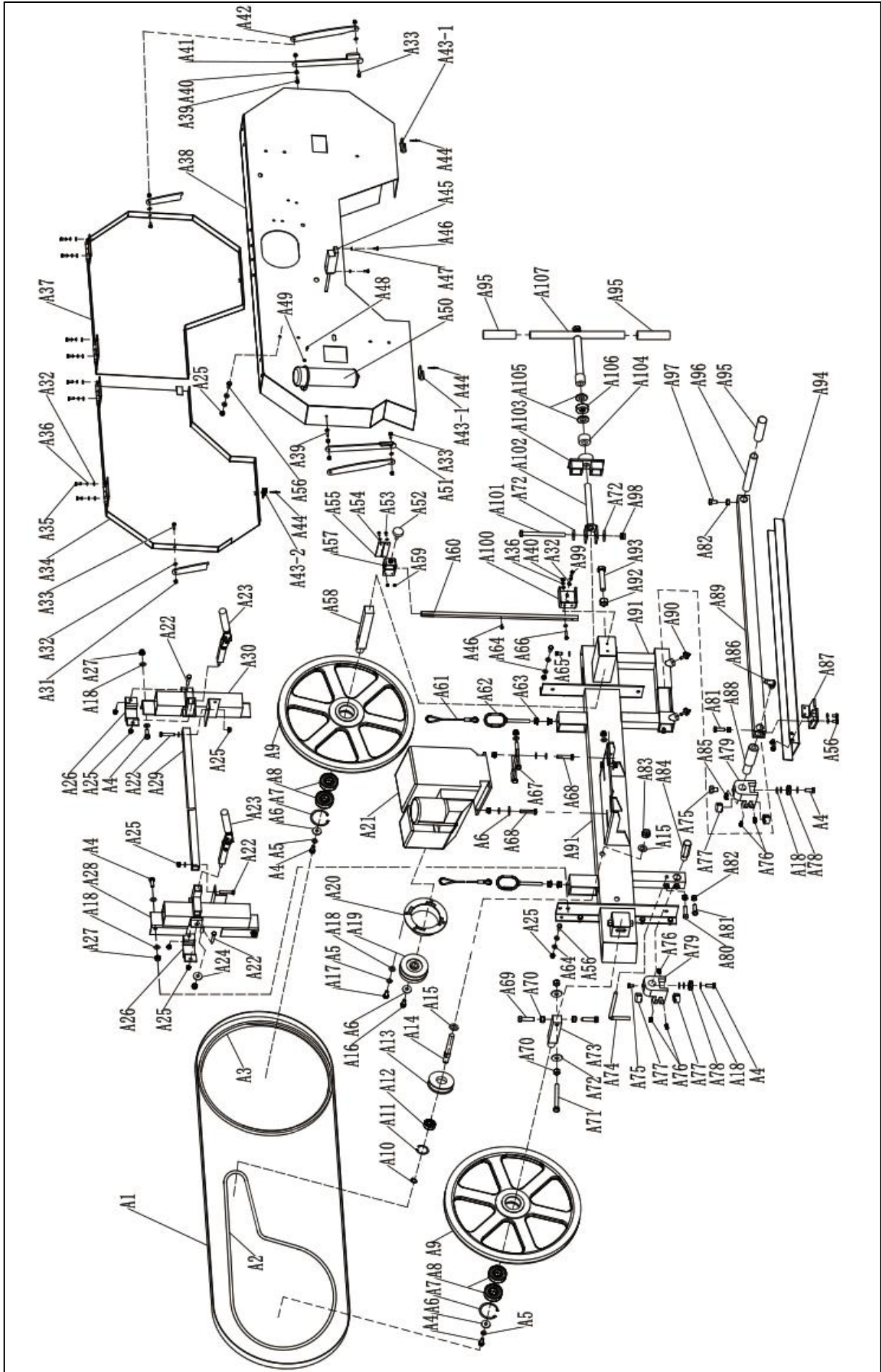

DIAGRAM (A) --BANDWHEEL HOUSING



PARTS LIST (A) -- BANDWHEEL HOUSING

| PART NO. | DESCRIPTION | QTY | PART NO. | DESCRIPTION | QTY |
|----------|---|-----|----------|--|-----|
| A1 | Saw blade | 1 | A35 | Cross pan head screw M6X16 | 8 |
| A2 | BX2007 Li V- belt | 1 | A36 | spring washer Ø6 | 12 |
| A3 | BX1473 Li V-belt | 1 | A37 | Left cover door welding | 1 |
| A4 | Hexagon head bolt M10X25 | 9 | A38 | Shield body welding | 1 |
| A5 | Spring washer Ø10 | 7 | A39 | Hexagon head bolt M6X20 | 2 |
| A6 | Large side flat pad 10 (Ø10*35*3.0) | 5 | A40 | Hex Nut M6 | 4 |
| A7 | Circlips for holes 62 | 2 | A41 | Side pull plate 3 | 1 |
| A8 | Deep groove ball bearing 6305 | 4 | A42 | Side pull plate 1 | 2 |
| A9 | Pulley | 2 | A43 | Buckle | 2 |
| A10 | Shaft circlip 17 | 1 | A44 | Blind rivet 4X10 | 8 |
| A11 | Circlips for holes 40 | 1 | A45 | Limit switch YBLX | 1 |
| A12 | Deep groove ball bearing 6203-2RS | 1 | A46 | Cross recessed pan head screw M5X12 | 3 |
| A13 | Tensioner | 1 | A47 | Spring washer Ø5 | 2 |
| A14 | tensioner shaft | 1 | A48 | Blind rivets 4X16 | 3 |
| A15 | Flat washer Ø16 | 1 | A49 | Large flat pad 4 | 3 |
| A16 | US 3/8X24X25 | 1 | A50 | Instruction manual | 1 |
| A17 | US 3/8X16X25 | 4 | A51 | Side pull plate 2 | 1 |
| A18 | Flat washer Ø10 | 22 | A52 | M8X40 flower handle | 1 |
| A19 | Clutch | 1 | A53 | Cross recessed pan head screw M4X12 | 2 |
| A20 | Clutch guard welding | 1 | A54 | Flat washer Ø4 | 2 |
| A21 | Engine | 1 | A55 | Scale plate | 1 |
| A22 | Hexagon head bolt M8X40 | 4 | A56 | Hexagon head bolt M8X20 | 11 |
| A23 | Quick lock | 2 | A57 | Scale holder | 1 |
| A24 | Large washer Ø10 | 5 | A58 | Passive saw wheel shaft | 1 |
| A25 | Non-metallic insert hex lock nut M8 | 16 | A59 | Hex nut M4 | 2 |
| A26 | Locking plate weldment | 2 | A60 | Height Indicator Rod | 1 |
| A27 | Non-metallic insert hex lock nut M10 | 11 | A61 | lifting wire | 2 |
| A28 | Right lift lock welding | 1 | A62 | Lifting rings | 2 |
| A29 | Tube | 2 | A63 | Hexagon flange face nuts M10 | 4 |
| A30 | Left lift lock welding | 1 | A64 | Flat washer ç8 | 17 |
| A31 | Non-metallic insert hex lock nut M6 | 8 | A65 | Hexagon head bolt M8X16 | 1 |
| A32 | Flat washer Ø6 | 18 | A66 | Hexagon head bolt M6X25 | 2 |
| A33 | Hexagon head bolt M6X16 | 6 | A67 | Tension plate | 1 |
| A34 | Right cover door welding | 1 | A68 | Hexagon head bolt M10X50 | 4 |

PARTS LIST (A) -- BANDWHEEL HOUSING (CONT)

| PART NO. | DESCRIPTION | QTY | PART NO. | DESCRIPTION | QTY |
|----------|--|-----|----------|---|-----|
| A69 | Hexagon head bolt M12X45 | 2 | A89 | Guide square tube | 1 |
| A70 | Hex Nut M12 | 4 | A90 | Triangle handle M10X40X30 | 2 |
| A71 | Hexagon head bolts full thread M12X100 | 1 | A91 | Beam welding | 1 |
| A72 | Large washer 12 (Ø12*35*3.0) | 4 | A92 | Hex Nut M16 | 1 |
| A73 | Active saw wheel shaft | 1 | A93 | Hexagon head bolt M16X80 | 1 |
| A74 | Saw hook | 1 | A94 | Saw guard plate 2 | 1 |
| A75 | Hexagon head bolt M10X12 | 2 | A95 | 25 tube rubber handle | 3 |
| A76 | Hexagon socket head set screw M6X12 | 12 | A96 | Push handle | 1 |
| A77 | Saw block for aluminum seat | 4 | A97 | Hexagon bolt M10 x 20 | 1 |
| A78 | Deep groove ball bearing 6200-2RS | 2 | A98 | Non-metallic insert hex lock nut M12 | 1 |
| A79 | Aluminum saw chuck shaft seat | 2 | A99 | Hexagon socket head cap screws M6X14 | 2 |
| A80 | Hexagon bolt M10 x 35 | 1 | A100 | scale seat | 1 |
| A81 | Hexagon head bolt M10X30 | 2 | A101 | Hexagon bolt M12X150 half wire | 1 |
| A82 | Hex Nut M10 | 5 | A102 | Tension rod welding | 1 |
| A83 | Non-metallic insert hex lock nut M16 | 1 | A103 | Tension seat welding | 1 |
| A84 | The right saw shaft | 1 | A104 | Cushion | 1 |
| A85 | One M6 90 degree oil cup | 1 | A105 | Tension gasket (Ø21*38*4.5) | 2 |
| A86 | 1/4 elbow external connection | 1 | A106 | Thrust ball bearing for automobile steering knuckle 51204 | 1 |
| A87 | Saw guard plate 1 welding | 1 | A107 | Tension handle welding | 1 |
| A88 | Left saw chuck shaft | 1 | | | |

PARTS LIST (B) --CARRIAGE

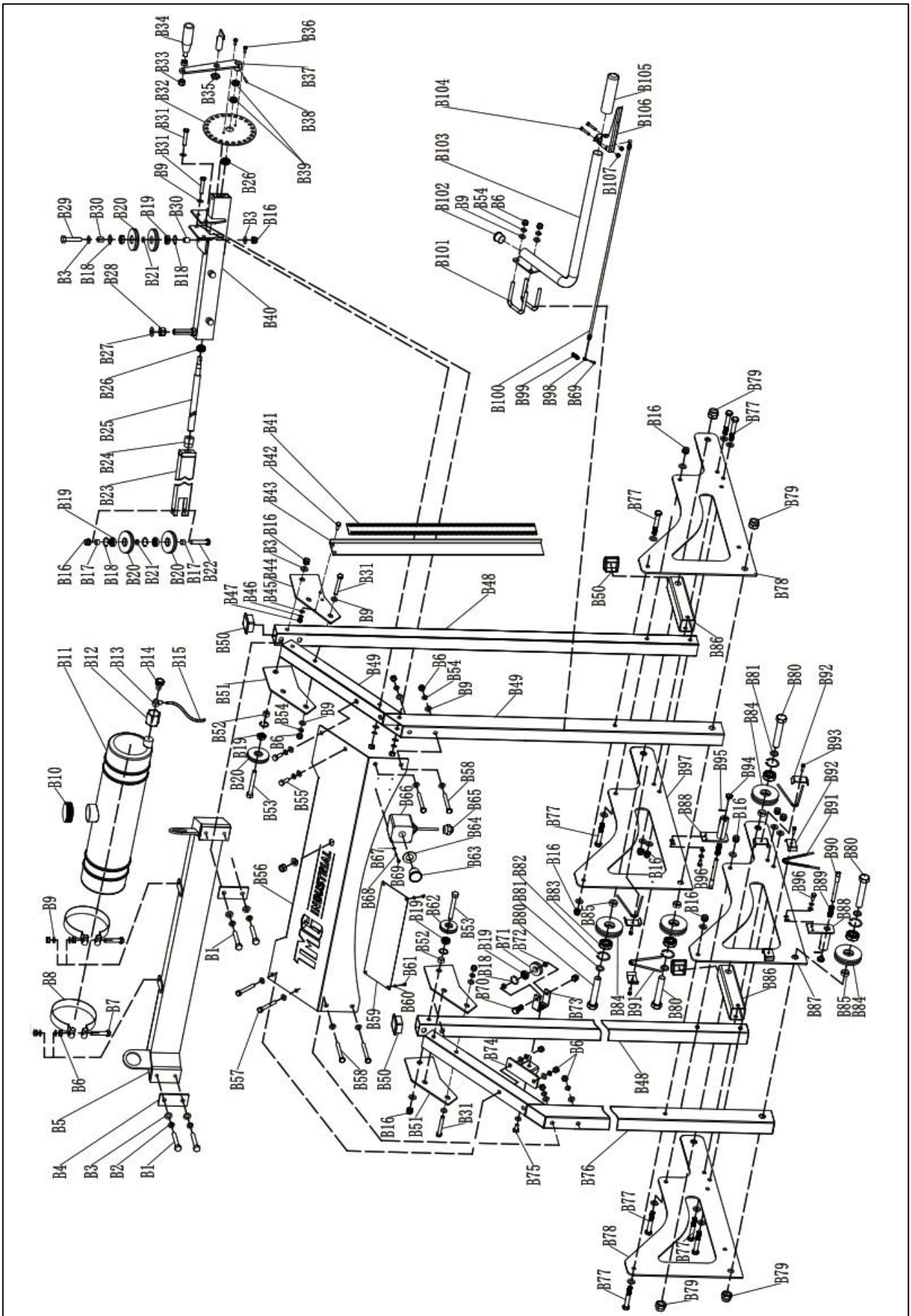

PARTS LIST (B) --CARRIAGE

| PART NO. | DESCRIPTION | QTY | PART NO. | DESCRIPTION | QTY |
|----------|---|-----|----------|-------------------------------------|-----|
| B1 | Hexagon head bolt M12X75 half wire | 4 | B34 | 13 hole handle | 1 |
| B2 | Spring washer Ø12 | 4 | B35 | Knob plunger assembly | 1 |
| B3 | Flat washer Ø12 | 24 | B36 | Hexagon head bolt M6X16 | 2 |
| B4 | Clamping plate | 2 | B37 | Rocker welding | 1 |
| B5 | Upper beam welding | 1 | B38 | Elastic cylindrical pin 5X24 | 1 |
| B6 | Hex Nut M10 | 20 | B39 | Round nut M14X1.5 | 2 |
| B7 | Hexagon head bolt M10X105 | 2 | B40 | Expansion tube 2 welding | 1 |
| B8 | Water Tank Rack | 2 | B41 | Height Ruler | 1 |
| B9 | Flat washer Ø10 | 35 | B42 | Hexagon head bolt M8X20 | 2 |
| B10 | Water tank cover | 1 | B43 | Ruler base | 1 |
| B11 | Water tank | 1 | B44 | Connecting plate 3 | 1 |
| B12 | Water Tank Connector | 1 | B45 | Flat washer Ø8 | 6 |
| B13 | Quick connect CSL8-04 | 1 | B46 | Spring washer Ø8 | 6 |
| B14 | Throttle valve | 1 | B47 | Hex Nut M8 | 2 |
| B15 | PU high pressure air pipe 8*5 transparent-1.8 m | 1 | B48 | Lifting Square Tube | 2 |
| B16 | Non-metallic insert hex lock nut M12 | 13 | B49 | Left Bottom Wheel Frame Welding | 1 |
| B17 | Spacer 1 | 2 | B50 | 50*50 square pipe plug | 6 |
| B18 | Circlips for holes 28 | 7 | B51 | Connecting plate 1 | 3 |
| B19 | Deep groove ball bearing 6001RS | 7 | B52 | Lifting Wheel Cover | 2 |
| B20 | Lifting wheel | 5 | B53 | Hexagon head bolt M12X95 half wire | 2 |
| B21 | Spacer 2 | 2 | B54 | Spring washer Ø10 | 18 |
| B22 | Hexagon head bolt M12X65 half wire | 1 | B55 | Hexagon head bolt M10 x 30 | 2 |
| B23 | Telescopic Tube 1 Welding | 1 | B56 | Upper dome cover | 1 |
| B24 | Copper nut | 1 | B57 | Hexagon head bolt M10X75 half wire | 2 |
| B25 | Lifting Screw | 1 | B58 | Hexagon head bolt M10X90 half wire | 4 |
| B26 | Thrust ball bearing 51102 | 2 | B59 | Trademark bezel | 1 |
| B27 | Flat washer Ø16 | 2 | B60 | Spring pad 5 | 6 |
| B28 | Hex Nut M16 | 2 | B61 | Cross recessed pan head screw M5X8 | 6 |
| B29 | Hexagon head bolt M12X85 half wire | 1 | B62 | Right Lifting Wheel | 1 |
| B30 | Reversing wheel set | 2 | B63 | Mushroom head emergency stop button | 1 |
| B31 | Hexagon head bolt M10X80 half wire | 6 | B64 | Emergency stop sign | 1 |
| B32 | Dial | 1 | B65 | Can't take off M20 | 1 |
| B33 | Hex Nut M12 | 2 | B66 | Button box CA-BX1 one hole | 1 |

PARTS LIST (B) --CARRIAGE (CONT)

| PART NO. | DESCRIPTION | QTY | PART NO. | DESCRIPTION | QTY |
|----------|---|-----|----------|---|-----|
| B67 | Flat washer Ø4 | 4 | B88 | Limit welding | 2 |
| B68 | Spring washer Ø4 | 4 | B89 | Small Compression Spring | 2 |
| B69 | Cross recessed pan head screw M4X12 | 5 | B90 | Limit shaft | 2 |
| B70 | Hexagon head bolt M12X30 | 1 | B91 | Wire rope brush | 4 |
| B71 | 7001-230040 Pulley 2 | 1 | B92 | Splint 2 | 4 |
| B72 | 7001-240030 Spacer 1 | 2 | B93 | Hexagon head bolt M6X20 | 4 |
| B73 | 7001-230010 Pulley frame welding | 1 | B94 | Small round handle M5 | 2 |
| B74 | Pulley frame seat | 1 | B95 | Split elastic pin 2.5X16 | 2 |
| B75 | Hexagon head bolt M10 x 20 | 1 | B96 | Hexagon head bolt M8X16 | 4 |
| B76 | Right Bottom Wheel Frame Welding | 1 | B97 | Left reinforcement plate welding | 1 |
| B77 | Hexagon head bolt M12X80 half wire | 8 | B98 | Wire clip | 1 |
| B78 | Outer reinforcement plate | 2 | B99 | Tension spring (engine) | 1 |
| B79 | Non-Metallic Insert Hex Lock Nut M20 | 4 | B100 | Throttle Cable | 1 |
| B80 | Hexagon head bolt M20X110 half wire | 4 | B101 | U-bolt | 2 |
| B81 | Bottom wheel spacer 1 | 4 | B102 | 33 round pipe plug | 1 |
| B82 | Circlip for hole 42 | 4 | B103 | Push handle welding | 1 |
| B83 | Deep groove ball bearing 6004 | 4 | B104 | Hexagon socket head cap screws M6X35 | 2 |
| B84 | Bottom wheel | 4 | B105 | Grip cover Ø32 | 1 |
| B85 | Bottom wheel spacer 2 | 4 | B106 | Throttle handle | 1 |
| B86 | Bottom wheel frame gasket | 2 | B107 | Hex Nut M6 | 2 |
| B87 | Right reinforcement plate welding | 1 | | | |

DIAGRAM (C) --GUIDE RAIL

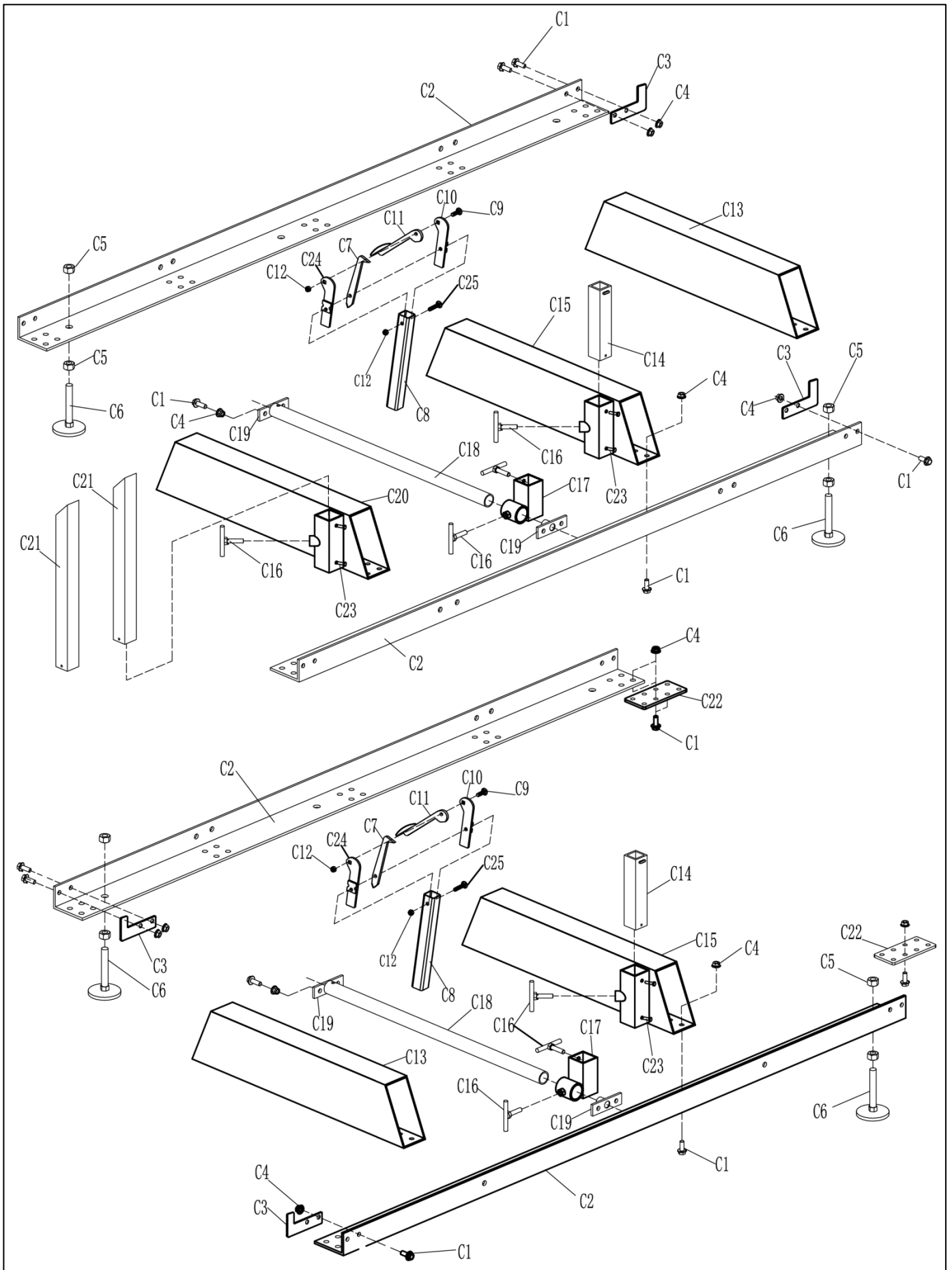

PARTS LIST (C) -- GUIDE RAIL

| PART NO. | DESCRIPTION | QTY | PART NO. | DESCRIPTION | QTY |
|----------|--|-----|----------|---|-----|
| C1 | Hexagon flange bolts M10*30 | 48 | C14 | Log support | 2 |
| C2 | Guide rail | 4 | C15 | Two-hole guide rail beam welding | 2 |
| C3 | Limit plate | 4 | C16 | T-screw M10*40 | 7 |
| C4 | Hexagon flange self-locking nuts M10 | 48 | C17 | Log clamp receiver | 2 |
| C5 | Hex nut M16 | 24 | C18 | Slide tube | 2 |
| C6 | Leveling Feet M16 | 12 | C19 | Sliding socket welding | 4 |
| C7 | Hook | 2 | C20 | Four-hole rail beam welding | 1 |
| C8 | Telescopic tube welding | 2 | C21 | Log support | 2 |
| C9 | Hexagon socket head screw M10X35 | 2 | C22 | Rail connecting plate | 2 |
| C10 | Telescopic left plate welding | 2 | C23 | Hex Bolts M8*30 | 6 |
| C11 | Eccentric compression welding | 2 | C24 | Telescopic right plate welding | 2 |
| C12 | Hexagon lock nut M10 | 4 | C25 | Half round head square neck bolt M10x35 | 2 |
| C13 | Two-hole guide rail beam (not welded) | 2 | | | |