

4500-lb Pallet Jack Scale Truck

Model:TMG-PJ45S

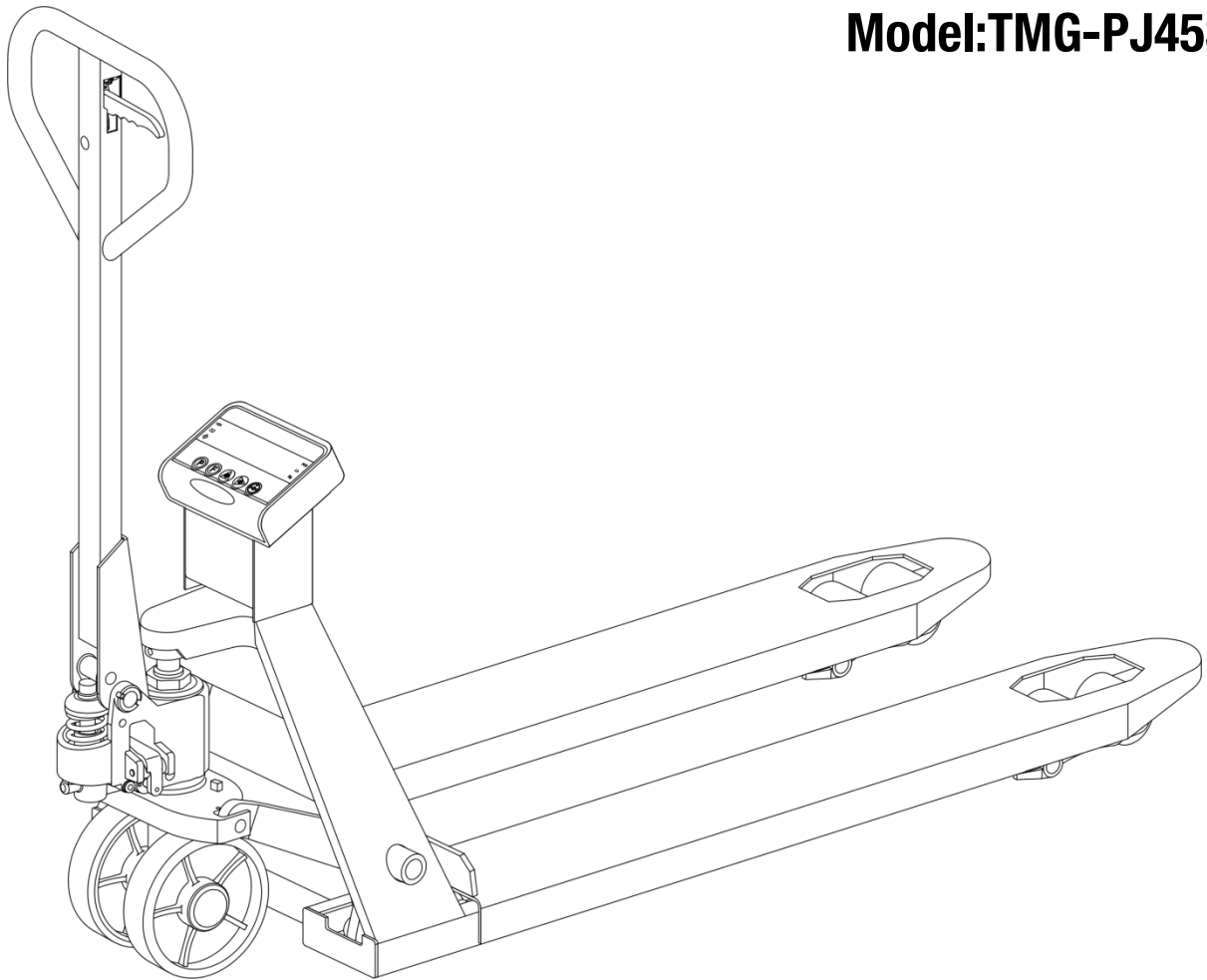

- Please read the product manual completely before assembly
- Check against the parts list to make sure all parts are received
- Wear proper safety goggles or other protective gears while in assembly

Missing parts or questions on assembly?

Please call: 1-877-761-2819 or email: cs@tmgindustrial.com

Do not return the product to dealer, they are not equipped to handle your requests

CONTENT

1. Instruction manual.....	3
1.1 Range of application.....	3
1.2 Operational order.....	3
1.3 Safety precautions.....	3
2. Product Description.....	4
2.1 Brief Introduction.....	4
2.2 Technical data.....	4
2.3 Diagram of Assembly.....	5
3. Operating instruction.....	7
3.1 Test run.....	7
3.2 Adjustment of control handle knob.....	8
3.3 Safety shutdown.....	8
4. Display instruction.....	8
4.1 Technical data of display.....	8
4.2 Display area introduction.....	9
4.3 Button Function Introduction.....	9
4.4 Calibration Introduction.....	10
4.5 Recharging Power.....	11
4.6 Warning.....	11
5. Trouble shooting.....	12
6. Routine Maintenance and Cleaning.....	13
7. Exploded Drawings and Parts List.....	15

1. Instruction manual

1.1 Range of application

Please use and maintain the scale pallet truck according to this instruction manual. Operations that are not listed in this manual may cause harm to the operator or the scale pallet truck, and may cause property damage. Please read the name plate before use, and make sure that the load isn't overweight. Please avoid unbalance load. Flammable, explosive, and humid environment may cause explode or short circuit of display.

1.2 Operational order

The scale pallet truck should be operated by well trained person, who knows how to do loading, is clear about contents in this instruction manual, and masters operating skills. All users should read and understand contents of this instruction manual. The manufacture will not be liable for any damage resulting from failure to comply with this instruction manual.

1.3 Safety precautions

- 1) Never lift a heavy load with just the points of the forks. This could damage the electronic weighing elements permanently.
- 2) Never weigh without a pallet. This could affect the accuracy of the weighing result.
- 3) Use caution in the vicinity of moving parts—these parts can cut and/or crush hands, arms, feet, and legs.
- 4) Always center the load you are lifting on both forks.
- 5) Do not operate the weighing system while others are on or near the unit.
- 6) It is the sole responsibility of the purchaser to train their own employees in the proper use and maintenance of this equipment.
- 7) Do not use the weighing system in potentially explosive areas.
- 8) Do not carry passengers with the truck.
- 9) Do not lift unstable loads.
- 10) Check the accuracy of the scale on a regular basis to prevent faulty readings.

2. Product Description

2.1 Brief Introduction

Scale pallet truck combines small manual pallet truck and weighing system, which is composed of high precision weighing sensor and digital display. Scale pallet truck can achieve carrying and weighing simultaneously, and each weighing data can be displayed automatically. It has advantages of smaller size, easy moving, convenient lifting/lowering, flexible steering, and accurate measurement.

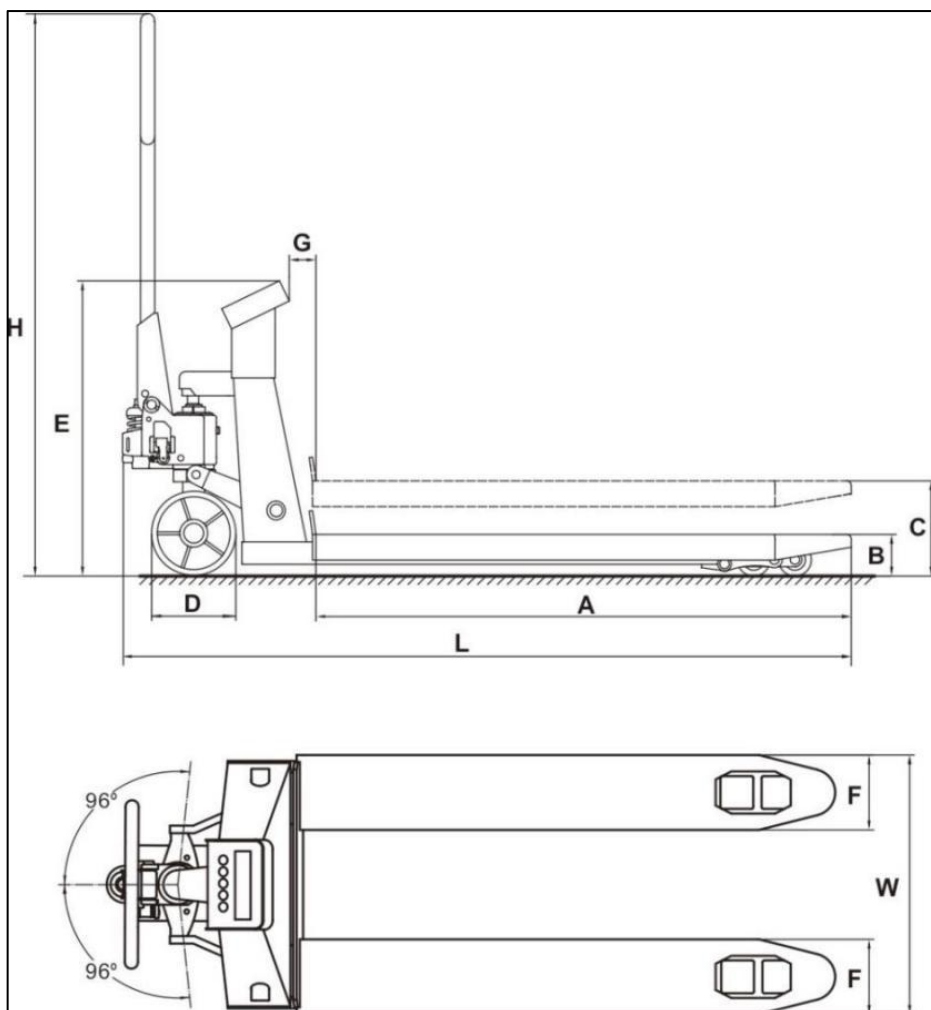

2.2 Technical data

Technical data of scale pallet truck (hardware):

Item/Model	Unit	TMG-PJ45S
Rated Load	lbs	4500
Overall Length L	In.	64
Overall Height H	In.	47-1/4
Fork Length A	In.	44
Fork Lowest Height B	In.	3-1/8
Fork Highest Height C	In.	7-1/2

Indicator Clearance G	In.	2-1/2
Height to Top of Indicator E	In.	26-1/2
Overall Width W	In.	27
Fork Width F	In.	6-1/4
Diameter of Carrying Wheel	In.	2-3/4
Diameter of Steering Wheel D	In.	7
Weight	KG	99
Input voltage		AC100~240V(+10%, -15%)- 50~60HZ

2.3 Diagram of Assembly

Scale pallet truck is composed of fork assembly, frame assembly, display assembly, pump assembly, and control handle assembly.

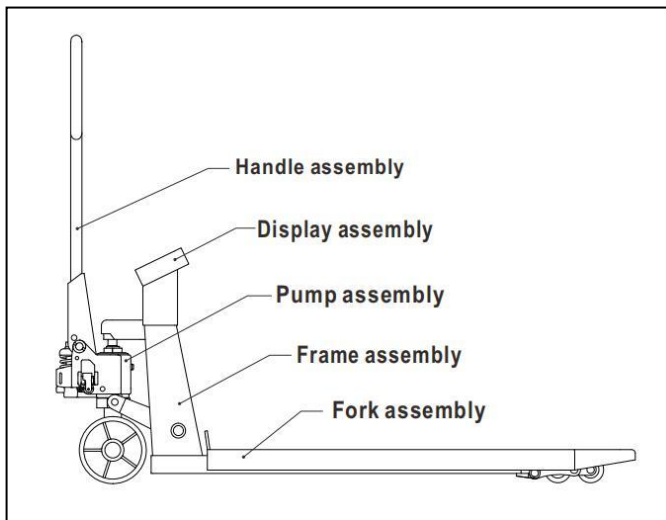
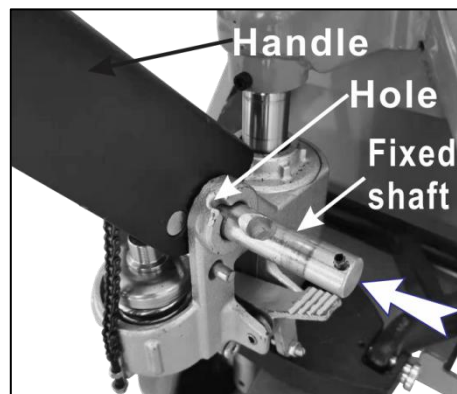
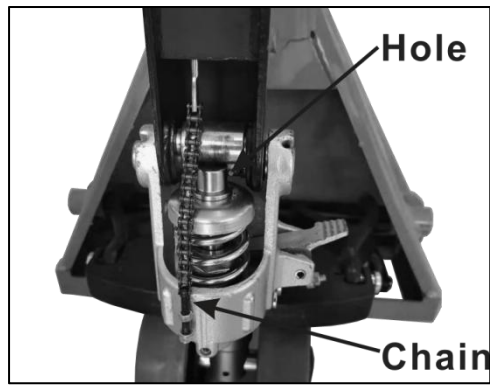
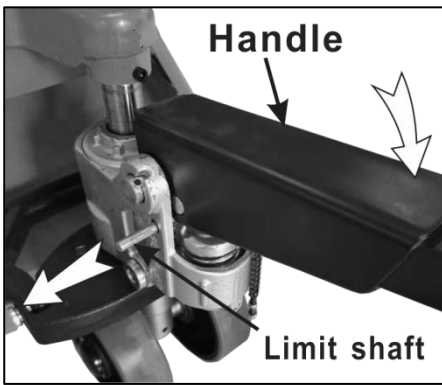

Figure 1: Structure of Scale Pallet Truck

1) Installation of pump handle



- A. Make sure the lever is pushed down to the “pump” position.
- B. Place the handle on the middle of the pump, and thread the fixed shaft through the hole in the pump and handle.



C. Press the handle to the lowest position, and remove the limit shaft.

D. Thread the chain through the hole in the fixed shaft.

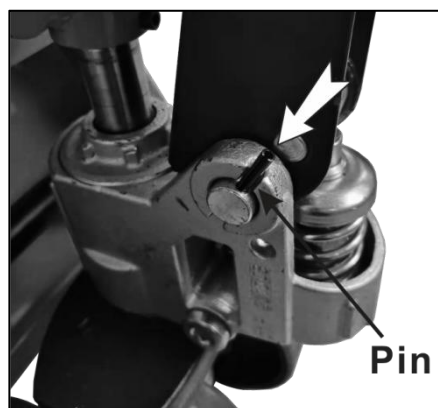

E. Insert the screw into the lever plate.

F. Knock the pin into the hole in the fixed shaft.

2) Installation of display

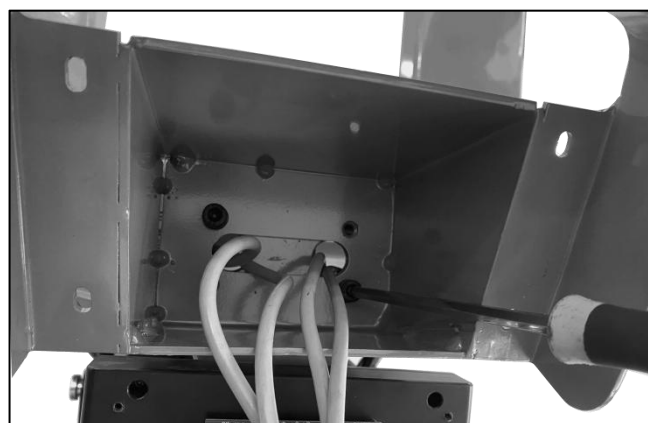
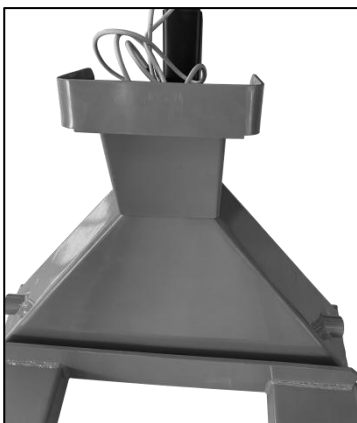

Fix the supporting structure on the frame with screws.

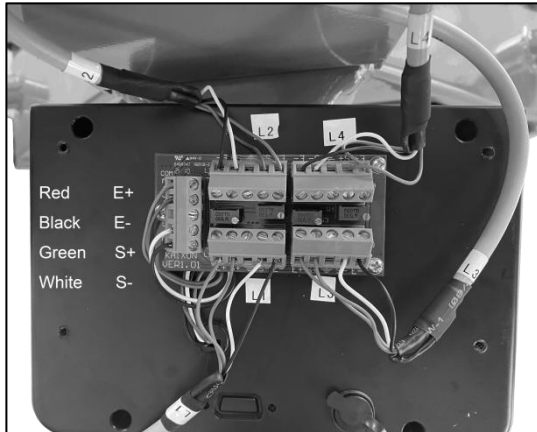
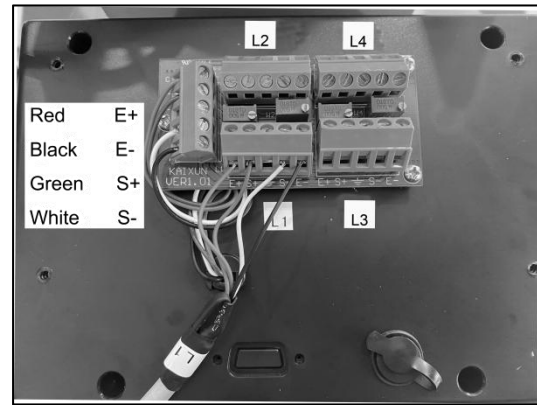
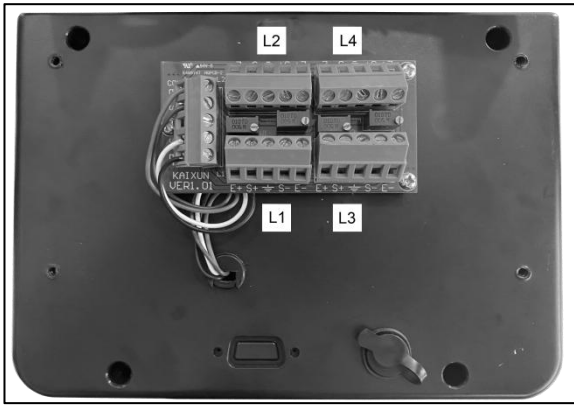

Wire of Sensor	Symbol of Socket
Red	E+
Black	E-
Green	S+
White	S-

A) Fix the circuit board on the back of display with screws, and then fix the wires of sensor to the circuit board according to the table.



B) install the display into the rack, and fix with screws. Please be cautious of the wire harness.

3. Operating instruction

3.1 Test run

Test run is only allowed at safe area, and only staff present. The load's center of gravity should be between the forks. Please don't put the load at the end of forks. Evenly distributed weight can maximum carrying capacity.

3.2 Adjustment of control handle knob

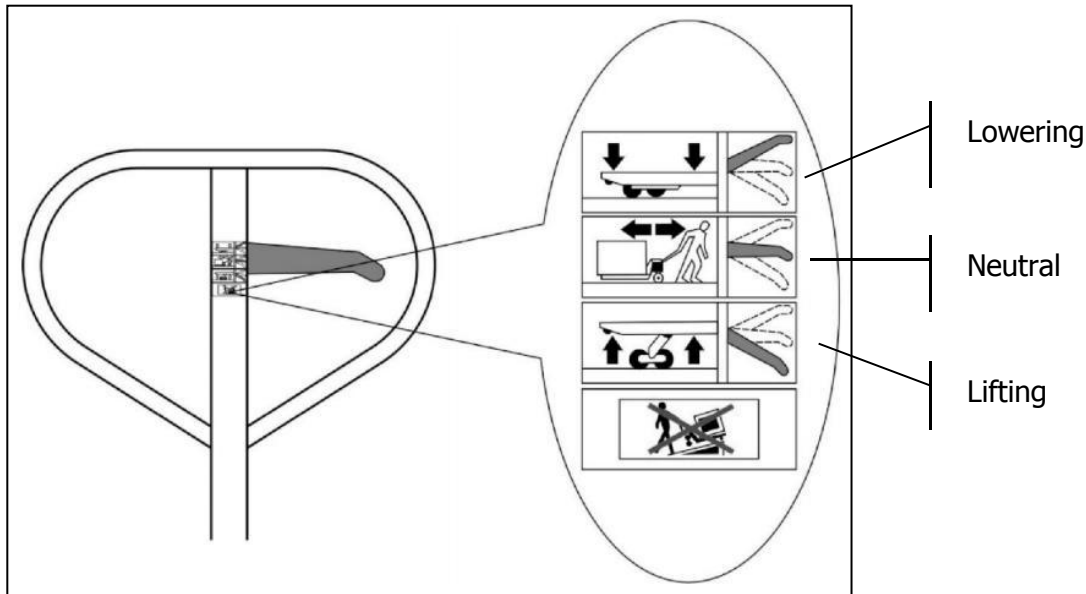

The control handle switch has three positions. Press down the handle switch to lower position, then pump the handle up and down to lift load. When keeping the switch at the neutral position, the forks will not be able to lift. When pulling the pallet truck, the switch should be kept at neutral position. Forks will lower down when lift the switch to upper position. When release the switch, it will goes back to neutral position automatically. Please make sure the forks are totally under the load before lifting.

3.3 Safety shutdown

Please don't park on the slope. Forks should be at lowest position when parking, and wheels should be fixed after parking. Fence should be used to protect the truck while transfer.

4. Display instruction

4.1 Technical data of display:

Standard	GB/T 7724-2008
Accuracy Class	Grade 3
Input Sensitivity	$\geq 1.5 \text{ uV/e}$
Power	7.4V/4000mAh Lithium cell
Operating Temperature	0°C~40°C , Humidity 10%~85% (RH)
Storage Temperature	-20°C~60°C , Humidity 10%~95% (RH)

4.2 Display area introduction

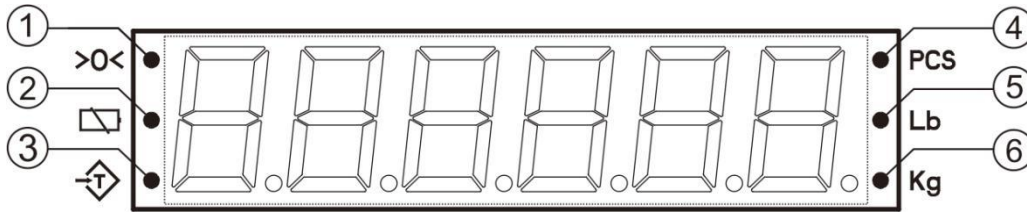

1. Null point 2. Low power 3. Tare 4. Counting mode 5. Lb 6. Kg

4.3 Button Function Introduction



Turn on and off button/zero-setting button

This button is used for power on and off.

It is also used for zero-setting if value is in the range of zero-setting.



Tare button/right shift button

This button is used for taring except negative value when turn on or over the max. weight.

It is right shift button during the function setting and calibration operation.



Unit button/ load button

This button is unit conversion button, which can be used to convert kg and lb.

It is used as load button during function setting operation and calibration operation.



Function button















This button is use for function setting such as count, lock and accumulative total













Print button/enter button

This button is used for print when the printer is connected.

During function setting operation and calibration operation, it is used for confirmation.





	Operation	Display	Remark
1 Charge	Plug in external power supply	[CHArGE] [---] [PbtXX] [-End-]	Charging Charging, scroll display from right to left Showing the charging capacity End of charge
2 Boot	Press and hold  for 1 second	[-t 15-] [UEr2.01] [17.09.03] [09.38] [Pbt 85] [8. 8. 8.] [0.0]	Appearance Model Software Version Number Date(year.month.day), set showing with the clock Time(hour.second), set showing with the clock Appearance battery power is 85% Appearance self-check, scroll display from right to left Weighting status
3 Shutdown	Press and hold  for 2 seconds	[Pbt 80] [OFF]	Appearance battery power is 80% Cut off the power supply
4 Zero Setting	Press 	[xx.x] [0.0]	Weight is less than the zero setting range 10%FS, and stable Zero setting, [Zero] light on.
5 Without Tare	Press 	[positive value] [0.0]	Weight is large than zero and stable. [Without tare] light on, showing the net weight. It can be repeated.
6 Clear	Press 	[display negative value]	[Without tare]light on or Zero light on. Clear the package weight, the light off.
7 Unit Conversion	Press  Press 	[xx.x] [yy-y]	“Pound” shows, [lb] light on (Permit swift) “kg” shows, [kg] light on.
8 Print	Press 	[xxa]	Weight is larger than minimum weight, and the weight is stable. Weigh should return to zero before next weighing. (<20d)
9 Sample count			Weigh return to zero before counting.
	Press 	[PCS 10]	Enter sample count mode.
	Press 		Choose sample 10, 20, 50, 100
	Press 		Put sample on truck, then press  to confirm. Count showed on screen, and [PCS] light is on.
	Press  Press  four times		Check unit weight and total weight. Back to weighing model, and [PCS] light is off

10 Lock	Press  two times	[Hold]	Enter weigh lock mode.
	Press 		Enter lock mode. When weight is stable, the weigh is locked.
	Press 	[0]	Exit weigh lock mode, and back to weigh mode.
	Press  one times		Enter accumulate function.
11 Accumulate	Press  three times	[ACC 12]	Choose 1 or 2. The selected one will flash.
	Press 	[ACC 12]	1. Manually accumulate 2. Automatically accumulate
	Press 		Enter accumulate mode.
	Press 		Shows cumulative number, 2 seconds later shows accumulative weight, 2 seconds later back to accumulate mode.
	Press 		Under selected mode 1, press  to print out cumulative number after weight is stable. Under selected mode 2, cumulative number will be printed out automatically after weight is stable. Cumulative number will be cleared automatically after shut down. Back to weighing mode.

4.4 Calibration Introduction

Calibration method:

Turn on the power, then press the  before zero-setting to enter the calibration interface.

Step	Operation	Display	Note
1		[xxxxxx]	Display A/D value, and check if the sensors are working.
2	Press 	[CAL 00]	Start zero correction, and confirm no-load. Press  when machine is stable.
3	Press 	[------]	Zero correction
4	A few seconds later	[1500.0]	Display the max. weight value for 2 seconds
5	2 seconds later	[-LoAd-]	Loaded weight
6	Press  	[100.0]	Input loaded weight value

7	Press (P)	[-----]	Range correction
8	A few seconds later	[100.0]	Display the loaded weight value, and enter the weighing mode

Note: 1 if zero is constant, only the range correction is made. When [CAL 00] is displayed, press the (>0<) to skip zero correction, and enter the range correction. (compensation calibration)

2 if only the zero correction is made, please press (→) (⚠), when [-LoAd-] is displayed. Input [0.0], and press (P) to back to the normal weighing interface.

4.5 Recharging Power

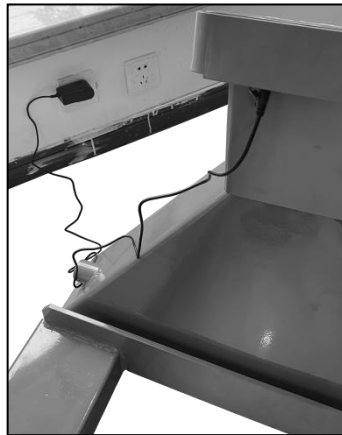

1. AC power: 100~240V/ 50~60Hz
2. Plug the round end of the charger into the port on the back of the display and then plug into the AC power supply. Reverse operation after full charge.

WARNING: If the machine is not used for more than 6 months, it must be charged every 6 months to reduce the battery life

4.6 Warning

1. It is strictly prohibited to put the scale on high temperature or humid place.
2. Do not let cockroach and organisms living in the machine.
3. Striking and overload is strictly prohibited.
4. If you have any suggestions, please feel free to contact us.

5. Trouble shooting

Fault Description	Reason	Method
Fork cannot reach the wanted height	Lacking of hydraulic oil.	Add hydraulic oil.
Fork cannot descend	1. Hydraulic oil is not pure.	1. Change hydraulic oil.
	2. Air in the hydraulic oil.	2. Bob up and down the handle to extract the air.
	3. The fork has been kept in high position for a long time, and the large piston is rusted.	3. Keep the fork in the minimum height when work is done. Pay attention to lubricate the piston lever.
	4. The adjustment nut or the adjustment screw is in an incorrect position.	4. Readjust the position of the adjustment nut or the adjustment screw.
Oil leak	1. Seal ring is burn-in.	1. Change seal ring.
	2. The cylinder is cracked.	2. Change cylinder
Forks descend without operation	1. Some of the hydraulic system elements are damaged or crazed.	1. Check and change the damaged elements.
	2. The adjustment nut or the adjustment screw is in an incorrect position.	2. Readjust the position of the adjustment nut or the adjustment screw.
Malfunction of Display	1. There is no value displayed on the indicator.	1. Check whether the power line is well connected.
	2. The key switch does not work.	2. Check whether the power line is well connected or change the key switch.

6. Routine Maintenance and Cleaning

The daily inspection and maintenance of scale pallet truck can improve the service time of the vehicle.

- 1) Check whether the pump is dripping.
- 2) Check whether there are sundries entangled in the wheels or axle.
- 3) Lubricate the moving parts of the pallet truck once a day.
- 4) Check whether the weighing display is well.
- 5) Do not place the vehicle in a intense direct sunlight area for a long time, otherwise, it may damage the display.
- 6) The battery should be charged in time when the power is low. Otherwise, it may short the service life of the battery.
- 7) Wipe the scale assembly with a damp cloth using water only.
- 8) Do not spray cleaners onto scale indicator.
- 9) Do not wash-down the vehicle with a pressure cleaner or water hose.
- 10) Do not allow water or liquids to drip on the scale indicator.

7. Exploded Drawings and Parts List

Main exploded drawings

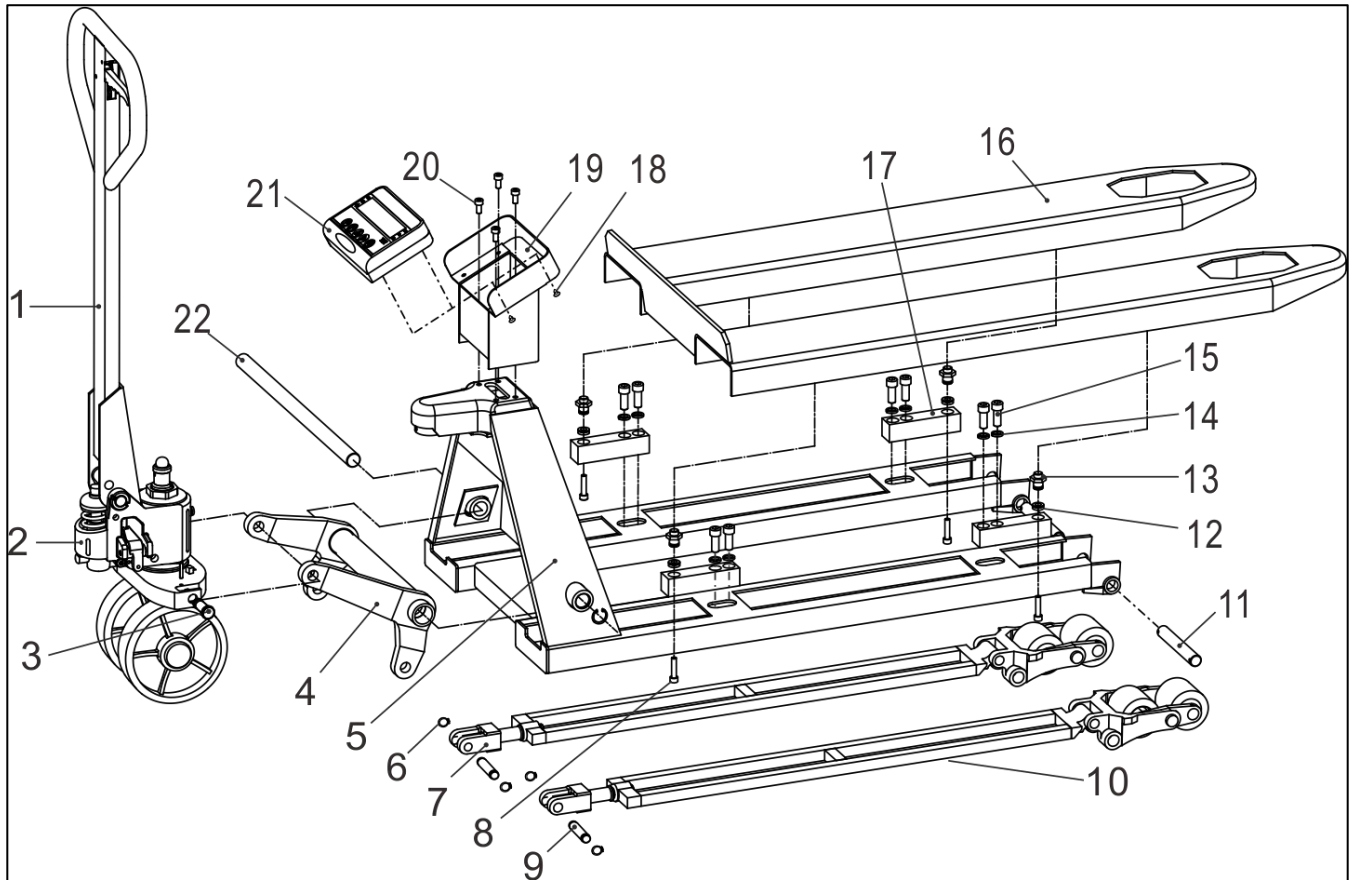

No.	DESCRIPTION	Q'TY	No.	DESCRIPTION	Q'TY
1	Handle assembly	1	12	Spherical composite washer	4
2	Pump assembly	1	13	Fork connection pin	4
3	Thrust plate pin	2	14	Spring washer ϕ 12	8
4	Swing arm	1	15	Screw M12X30	8
5	Frame assembly	1	16	Fork	1
6	Shaft ring ϕ 16	4	17	Weighing sensor	4
7	Pushing rod and load wheel assembly	2	18	Tapping screw 3X10	4
8	Screw M8X35	4	19	Supporting structure	1
9	Pushing rod pin	2	20	Screw M8X16	4
10	Transmission assembly	2	21	Display	1
11	shaft	2	22	Long shaft	1

Structure of Control Handle Assembly

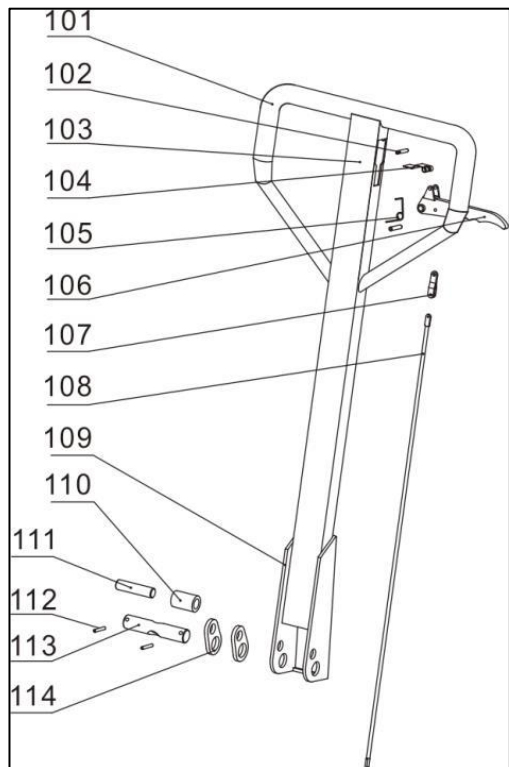

No.	DESCRIPTION	Q'TY
101	Handlebar	1
102	Spring pin	2
103	Handle	1
104	Limit board	1
105	Torsional spring	1
106	Lever	1
107	Connecting rod	1
108	Chain lever	1
109	Handle triangle	2
110	Pinch roller	1
111	Roller pin	1
112	Spring pin	2
113	Fixed pin	1
114	Subplate	2

Pump assembly

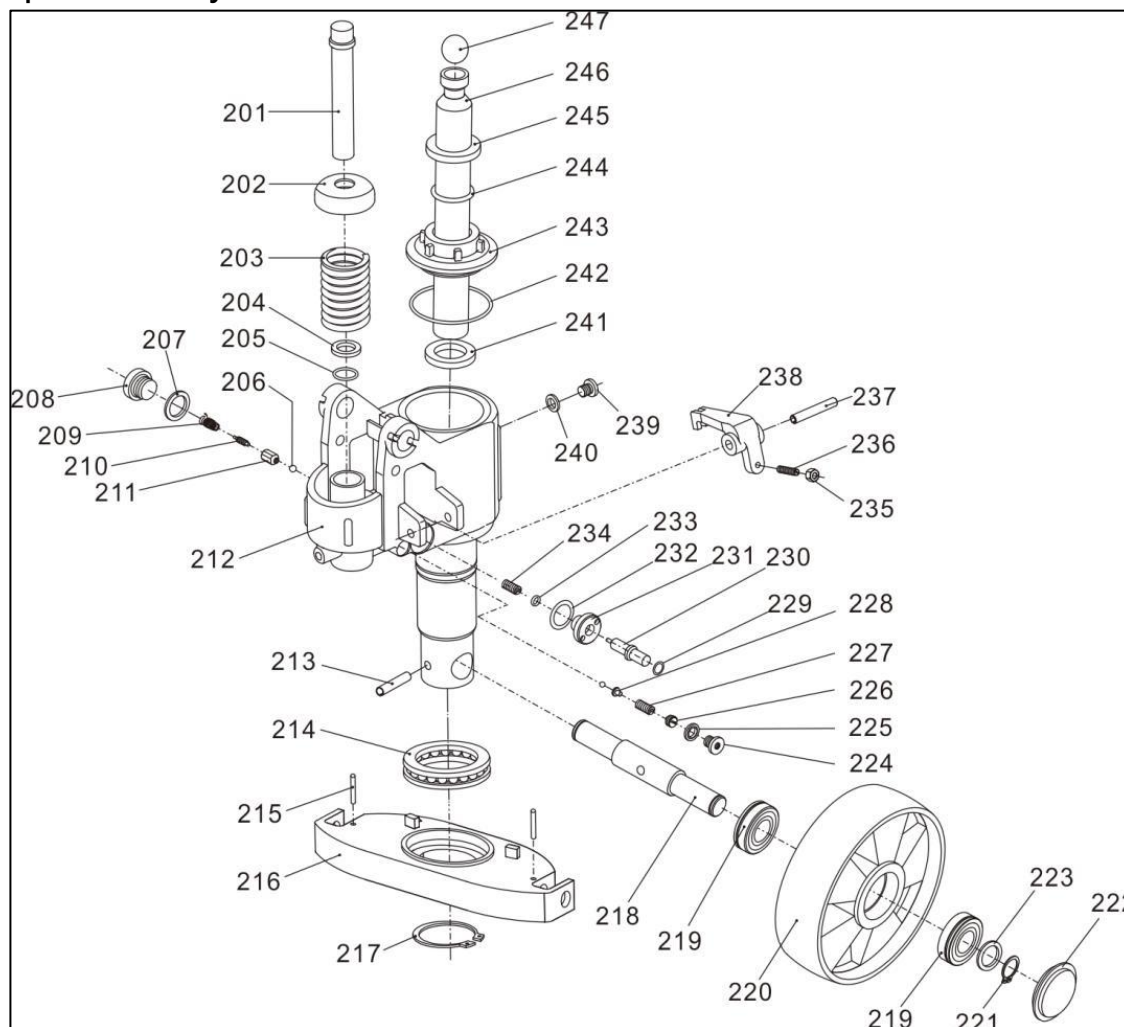

No.	DESCRIPTION	Q'TY	No.	DESCRIPTION	Q'TY
201	Pump core	1	225	Compound gasket Φ 10	1
202	Spring cap	1	226	Adjusting screw	1
203	Spring	1	227	Safety valve spring	1
204	Scraper seal	1	228	Steel ball pad	1
205	Seal ring	1	229	Gasket	1
206	Steel ball	1	230	Firing pin	1
207	Compound gasket	1	231	Firing pin seat	1
208	Screw-plug	1	232	Compound gasket	1
209	Volute spring	1	233	O ring	2
210	Valve core	1	234	Firing pin spring	1
211	Valve body	1	235	Nut	1
212	Pump body	1	236	Screw	1
213	Spring pin	1	237	Spring pin	1
214	Bearing	1	238	Lever plate	1
215	Spring pin	2	239	Screw	1
216	Thrust plate	1	240	Compound gasket	1
217	Shaft ring	1	241	Seal ring	1
218	Steering wheel shaft	1	242	O ring	1
219	Bearing	2	243	Pump cap	1
220	Steering wheel	2	244	O ring	1
221	Shaft ring	2	245	Scraper seal	1
222	Dust cover	2	246	Piston rod	1
223	Gasket	2	247	Steel ball	1
224	Adjusting screw	1			

Transmission assembly

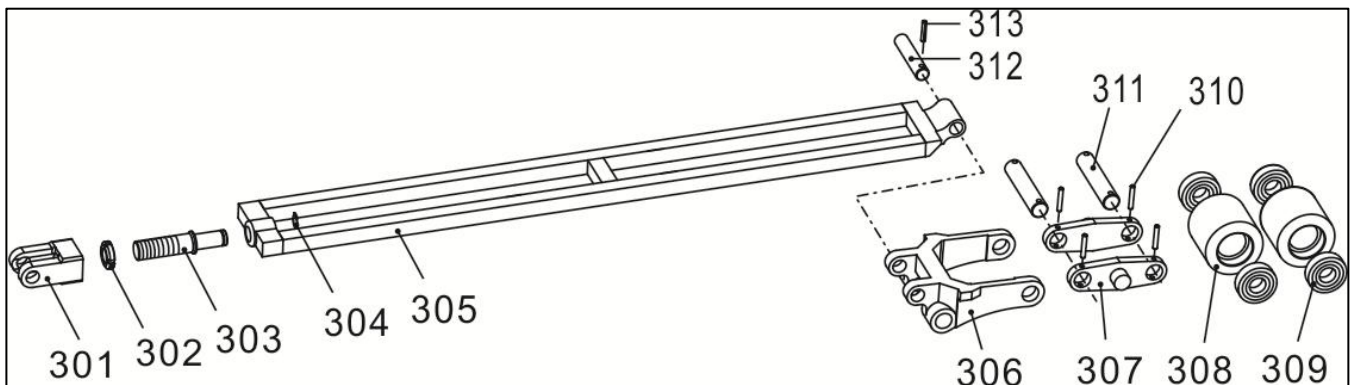

No.	DESCRIPTION	Q'TY	No.	DESCRIPTION	Q'TY
301	Joint	1	308	Load wheel	2
302	Nut M18	1	309	Bearing	4
303	Pushing rod bolt	1	310	Spring pin Φ 5X30	4
304	Shaft ring Φ 16	1	311	Load wheel pin	2
305	Pushing rod	1	312	Pushing rod connection pin	1
306	Frame of roller	1	313	Spring pin Φ 5X25	1
307	Linking plate	2			

Display assembly

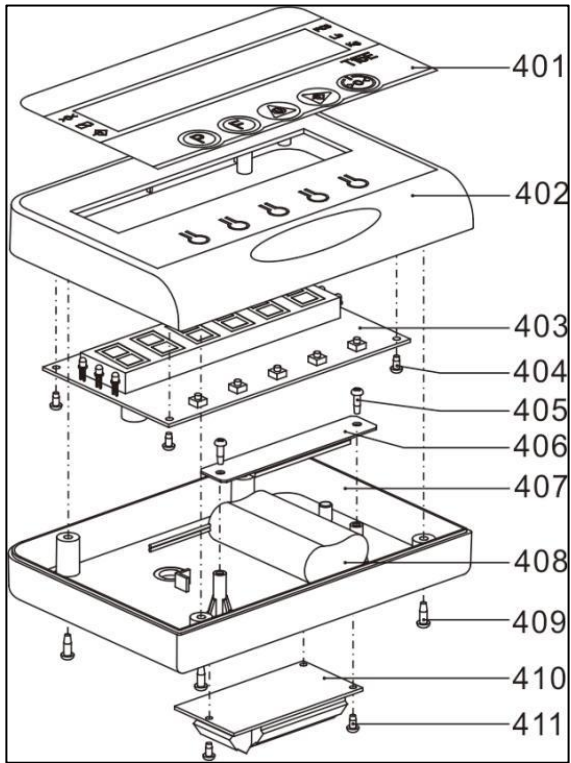

No.	DESCRIPTION	Q'TY
401	Operation panel	1
402	Upper cover	1
403	Mainboard of display	1
404	Tapping screw 3X8	4
405	Tapping screw 3X10	2
406	Battery holder	1
407	Pedestal	1
408	Battery	1
409	Tapping screw 3.5X10	4
410	Sensor connection circuit board	1
411	Tapping screw 3X6.5	3