

Reversible Plate Compactor

Model: TMG-PC160K

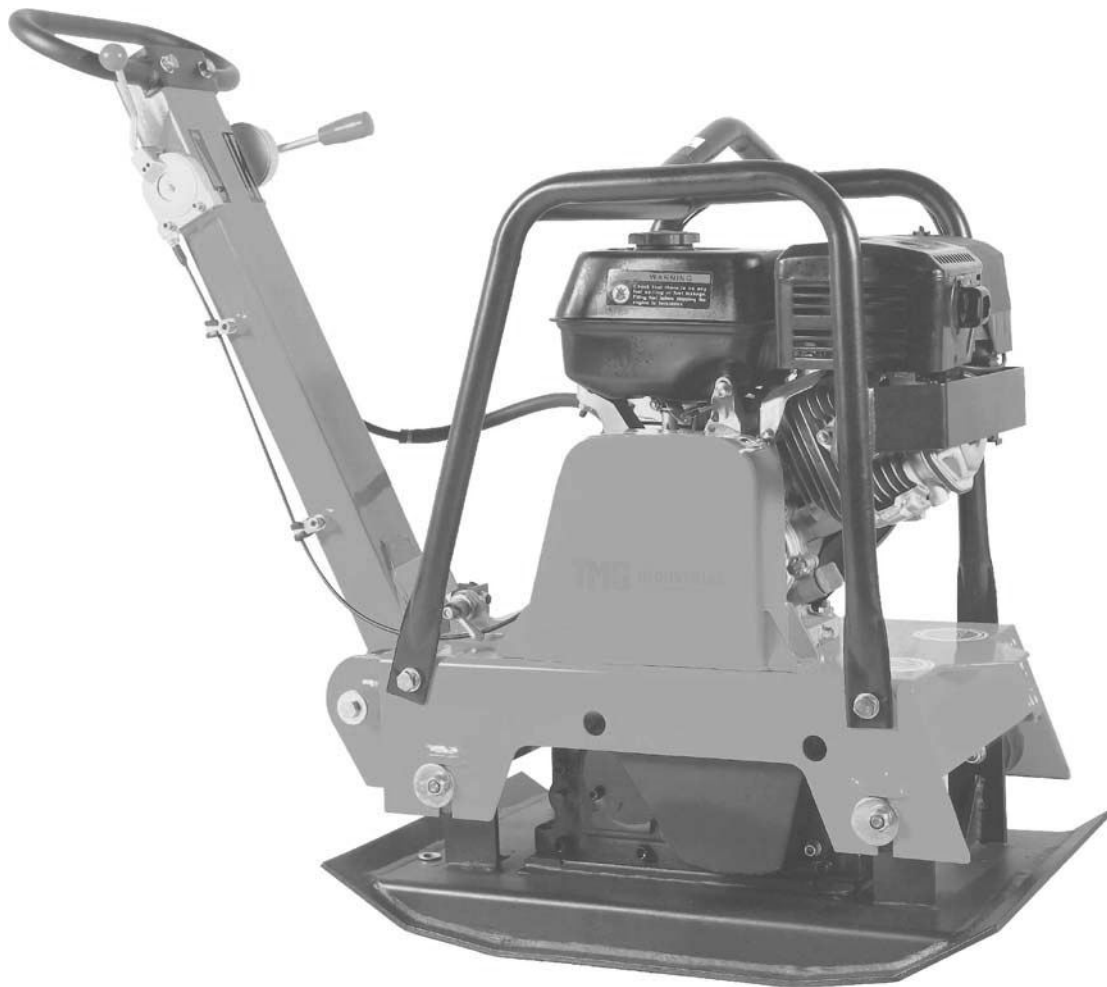

- Please read the product manual completely before assembly
- Check against the parts list to make sure all parts are received
- Wear proper safety goggles or other protective gears while in assembly

Missing parts or questions on assembly?

Please call: 1-877-761-2819 or email: cs@tmgindustrial.com

Do not return the product to dealer, they are not equipped to handle your requests

CONTENT

| | |
|--|--------|
| I .INTRODUCTION..... | -2- |
| II . APPLICATIONS | -2- |
| III. STRUCTURE..... | -3- |
| IV . FUNCTIONS AND CONTROLS..... | -3- |
| V . FOR SAFETY OPERATION..... | -3- |
| VI. HAZARDS AND RISKS | - 5 - |
| VII. OPERATION..... | - 7 - |
| 7.1 PRIOR TO OPERATION..... | - 7 - |
| 7.2 CAUTION..... | - 8 - |
| 7.3 STARTING..... | - 9 - |
| 7.4 OPERATION..... | - 10 - |
| 7.5 TRANSPORTATION..... | - 10 - |
| 7.6 SHUTDOWN..... | - 11 - |
| 7.7 SERVICE&STORAGE..... | - 11 - |
| VIII. CARE & PREVENTIVE MAINTENANCE..... | -13- |
| IX. SERVICE | - 13 - |
| X. TROUBLESHOOTING..... | -13- |
| XI. REPLACEMENT PARTS LIST..... | - 14 - |
| 10.1 MAJOR COMPONENTS..... | - 14 - |
| 10.2 VIBRATOR ASSEMBLY..... | - 16 - |

WARNING

To reduce the risk of injury , all operators and maintenance personnel must read and understand these instructions before operating , changing accessories or performing maintenance on equipment we produced . All possible situations cannot be covered in these instructions. Care must be exercised by everyone using, maintaining or work near this equipment.



CAUTION



NO OIL IN ENGINE

Fill the engine with oil to the correct level before starting the engine.

ДВИГАТЕЛЬ ПОСТАВЛЯЕТСЯ БЕЗ МАСЛА

Перед запуском проверьте и заполните до требуемого уровня.

MOTOR SIN ACEITE

Agregue aceite al motor al nivel correcto antes de encenderlo.

MOTOR SEM ÓLEO

Adicione óleo ao nível correto antes de ligar o motor.

I . INTRODUCTION

Thank you for your selection of our equipment.

We have taken care in the design, manufacture and testing of this product. Should service or spare parts be required, prompt and efficient service is available from our branches.

General Safety instructions for the Operation of Power Equipment. Our factory's goal is to produce power equipment that helps the operator work safely and efficiently. The most important safety device for this or any tool is the operator. Care and good judgment are the best protection against injury. All possible hazards cannot be covered here, but we have tried to highlight some of the important items, individuals should look for and obey Caution, Warning and Danger signs placed on equipment, and displayed in the workplace. Operators should read and follow safety instructions packed with each product.

Learn how each machine works. Even if you have previously used similar machines, carefully check out each machine before you use it .Get the "feel" of it and know its capabilities, limitations, potential hazards, how it operates, and how it stops. We has no duty if person don't operate as instruction said.

II . APPLICATIONS

Plate compactor is the machine that compacts the ground and it intends to make the surface smooth, by transmitting vibration through vibrating plate, which power generated from single motor in vibrator case This machine is suitable for making the ground surface smooth, such as leveling the soil and beaching, finishing the asphalt paving. Applications as followings:

Trench compaction

Earth works

Road maintenance

Landscaping

Brick paving

Driveway toppings

Warning for incorrect application and abuse

This machine is hard to move forward on a soil with much water (especially clay soil).It is not suitable for such application. This machine is difficult to level a ground include big stones due to insufficient compacting force. Plate compactor is mainly applied for compacting surface smooth and it is nor effective for jobs that requires heavy compaction. In case of compacting ground deeply into lower layer, it is recommended to use. Tamping Rammer, Vibrato Compactor and Vibration Roller which compacting force is rather effective.Please use this compactor for compacting surface on soil, sediment, sand , beaching and asphalt. It is not recommended for use this machine for the other applications.

III. STRUCTURE

The upper part is made up of Power Source, Handle ,Belt Cover and Guard Hook which are fixed by Engine base. The Engine base is fixed on Vibrating Plate by Shock Absorbing Rubber.The lower part is made up of Vibrating Plate and Vibrator unit that has an Eccentric rotary shaft built in. The power source is transmitted from the centrifugal clutch on engine output shaft to the eccentric rotary shaft via V-belt.

Power Transfer

Air-cooled single cylinder engine is amounted as power source and Centrifugal Clutch is fixed on engine output shaft. Petrol Engine(2 cycle, 4 cycle) and Diesel Gasoline Engine can be mounted as option. Centrifugal Clutch engages by running up the engine and engine is reduced o suitable number for compacting. The rotation of engine is transmitted from V-pulley integrated with Clutch drum to Vibrator pulley through V-belt. Vibrator Pulley rotates Eccentric rotor shaft that is contained in Vibrator case. The generated vibration created from eccentric rotor is transmitted to Compaction with the weight of the machine makes the compaction of the ground possible.

IV. FUNCTIONS AND CONTROLS

Motor:

The motor is controlled by an ON/OFF switch or push button which is mounted on the motor below the fuel tank.

The motor speed is controlled by a remote throttle lever which is mounted on the machine handle.

Honda and Kama motors are fitted with an oil alert device which will stop the motor or prevent starting when the crankcase oil level falls below a safe level

Drive belt:

Tension of the drive belt is adjustable. Loosen the four nuts on the bolts which secure the motor to the base plate, Adjust the set screws which bear against the motor crankcase to achieve the required belt tension .Ensure that the four nuts and the set screw lock nuts are tightened after adjustment.

V. FOR SAFETY OPERATION

 This safety alert symbol identifies important safety messages throughout this manual and on the machine. When you see this symbol, carefully read the message that follows. Your safety is at stake!

Foreword:

It is important to read this manual carefully so that you will fully understand the operational characteristics and performance of the plate compactor, Proper maintenance procedures will insure long life and top performance of the unit.

Safety:

This section outlines basic safety procedures that apply to the operation, maintenance and adjustment of the plate compactor. This unit is designed as a powerful, productive machine that should be operated with respect and caution.

Misuse or carelessness can result in serious injury or damage. or both. Safety precautions must be observed at all times.

Operator Qualifications:

Before operating this equipment, an individual should read this manual. Whenever possible, he should be shown how to operate the unit by an experienced operator. Inexperience is hazardous in operating any machine or attachment. Trial and error is not the way to become familiar with a piece of equipment. This is expensive, cuts equipment life and can create machine should not be left unattended when operating.

General Safety:

CAUTION

Protection required. Wear hard hat, shatterproof glasses, steel toed boots and other protective devices required by job conditions. Avoid jewelry or loose clothing. These many catch on controls or in moving parts and cause serious injury.

Starting Safety:

CAUTION

Poisonous fumes. Start and operate only in well ventilated area. Breathing exhaust gases can result in sickness or death.

Servicing Safety:

CAUTION

Flammable liquid. Stop engine and do not smoke or allow work in immediate area when refueling. Fire or explosion could result from flames or sparks.

Moving parts. Shutdown engine before performing. Service or maintenance. Contact with moving parts can cause serious injury.

Flight temperature. Allow machine and engine to cool before performing service or maintenance. Contact with hot components can cause serious burns.

Engine

See engine operations manual

SHUTDOWN

EMERGENCY SHUTDOWN

Move throttle lever to “OFF” position and also turn stop switch to “OFF”.

NORMAL SHUTDOWN

Move throttle lever quickly from “ON” to “OFF” and run engine for 3 to 5 minutes at low speed. After engine cools, turn stop switch to “OFF” position, Close fuel shutoff valve.

VI. HAZARDS AND RISKS

NEVER allow any person to operate the machine without adequate instruction .

ENSURE all operators read, understand and follow the operating instructions
SERIOUS INJURY could result from improper or careless use of this machine

Plate compactors are heavy units and should be positioned by two people of appropriate strength. Using the lifting handles provided on the machine, along with correct lifting techniques.



MECHANICAL HAZARDS

DO NOT operate the machine unless all protective guards are in place.

KEEP hands and feet clear of rotating and moving parts as they will cause injury if contacted.

ENSURE that the motor operation switch is in the OFF position and the spark plug ignition lead is disconnected before removing the guards or making adjustments.

ENSURE both the machine and the operator are stable by setting up on level terrain and the machine will not tip over, slide or fall while in operation or unattended.

DO NOT leave the machine in operation while it is unattended.

ENSURE that the walls of a trench are stable and will not collapse due to the action of the vibration ,prior to commencing compaction.

ENSURE that the area to be compacted does not contain any “live” electrical cables, gas, water or communication services which may be damaged by the action of the vibration.

EXERCISE CARE when operating unit. Exposure to vibration or repetitive work actions may be harmful to hands and arms.

NEVER stand on the unit while it is operating.

DO NOT increase the governed no-load motor speed above 3.500 r/min. Any increase may result in personal injury and damage to the machine.

BE CAREFUL not to contact with muffler when the engine is hot, since it can cause severe burns.

ENSURE that repairs to the motor and machine are carried out by specialists.



FIRE & EXPLOSION HAZARDS

PETROL is extremely flammable and explosive under certain conditions.

ENSURE that petrol is only stored in an approved storage container.

DO NOT refuel the motor while it is in operation or hot.

DO NOT refuel the motor in the vicinity of sparks, a naked flame or a person smoking.

DO NOT over fill the fuel tank and avoid spilling petrol when refueling. Spilled petrol or petrol vapor may ignite. If spillage occurs, ensure that the area is dry before starting the motor.

ENSURE that the fuel tank cap is securely fitted after refueling.

CHEMICAL HAZARDS

DO NOT operate or refuel a petrol or diesel motor in a confined area without adequate ventilation.

CARBON MONOXIDE exhaust gases from internal combustion motor driven units can cause death in confined spaces.

NOISE HAZARDS

EXCESSIVE NOISE can lead to temporary or permanent loss of hearing.

WEAR an approved hearing protection device to limit noise exposure. As required by Occupational Health and Safety regulations.

WEAR an approved hearing protection device to limit noise exposure. As required by Occupational Health and Safety regulations.

PROTECTIVE CLOTHING

ALWAYS wear approved hearing protection when working in a confined work space. Protective goggles and a dust mask should be worn when working in a dusty environment. Protective clothing and footwear may also be desirable when working with hot mix bitumen.

ADDITIONAL HAZARDS

Slip/Trip/Fall is a major cause of serious injury or death. Beware of uneven or slippery work surfaces. Exercise care when working in the vicinity of unprotected holes or excavations.

VII. OPERATION

GENERAL OPERATION

The machine is best suited to the compaction of bituminous and granular materials e.g. granular soils, gravels and sands or mixtures of both. Cohesive soils such as silt and clay are best compacted using the impact force produced by a vibrating rammer.

Where possible the site should be graded and leveled before commencing compaction.

Correct moisture content in soil is vital to proper compaction. Water acts as a lubricant to help slide soil particles together. Too little moisture means inadequate compaction; too much moisture leaves water-filled voids that weaken the soil's load bearing ability.

Use unleaded grade petrol and ensure that the fuel is free from contamination.

The vibratory motion provides a self propelling action. Position the handle at the opposite end of the machine to the vibrator.

Start the motor using the recoil starter. (If the motor is fitted with an on/off switch this must first be turned to ON before starting.)

For more information of starting and correct operating procedures of the motor, refer to the motor operation manual supplied with the unit.

Increase the motor speed to the maximum setting using the hand throttle lever, before commencing compacting.

The machine should be controlled by grasping the handle with both hands and applying restraint to control the forward motion. Forward or backward motion has problem, adjust the red handle or nuts (item 21, 22 in components list) Steer the machine by moving the handle sideways to the right or left.

ALWAYS maintain good footing so that you do not slip and lose control when starting or operating the machine.

7.1 PRIOR TO OPERATION

- 1-1. Make sure that all dirt, mud, etc., are thoroughly removed from the unit prior to operation. Special effort should be given to the bottom face of the vibrating plate and those areas adjacent to the cooling air inlet of engine, carburetor, and air cleaner.
- 1-2. Check all bolts and screws for tightness and make sure all bolts and screws are securely tightened. Loose bolts and screws may cause damage to the unit.
- 1-3. Check the V-belt for tightness. The normal slack should be approximately 10-15 mm (1/2") when the belts are forcibly depressed in the middle position between the two sheaves.

If there is excess belt play. There could be a decrease in the impact force or erratic vibration, causing machine damage.

1-4. Check the engine oil level and if the engine oil level is low, it should be refilled. Use the proper motor oil as suggested in the table below. (Fig-1)

1-5. Remove the oil plug in the vibrator assembly and check the oil level. Make sure the compactor is level when checking. The oil level should be up to the oil plug. Every month or every 200 hours of operation, replace the oil.

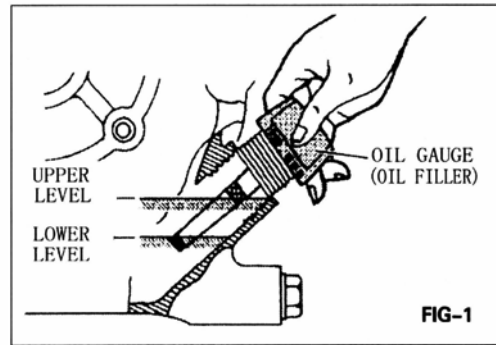

| Season Temperature | Grade of Motor oil (higher than MS class) |
|--|---|
| Spring Summer or Autumn +120° F to +40° F | SAE 30 |
| Winter +40° F to +15° F | SAE 20 |
| Below +15° F | SAE 10W-30 |

⚠ IMPORTION

Use the motor oil SAE

When changing the oil, the old oil can be drained by tipping the unit. The oil will drain easily while it is hot.

1-6. A regular grade gasoline should be used in the engine.

When filling the fuel tank, make sure the fuel filter is used.

7.2 CAUTION

2-1. Be careful with the operating place and ventilation. Avoid operating the machine in a closed room, tunnel, or other badly ventilated places, since its exhaust contains deadly poisonous carbon monoxide. If the machine is employed unavoidable operated in such a place, discharge the exhaust out the room by a suitable means.

2-2. Be careful with the hot members.

Mufflers and other hot members are dangerous.

Do not touch them with unprepared hand.

2-3, Observe with the following cautions when transporting. Clamp fuel tank cap securely, and turn the fuel have OFF at the source during Drain gasoline from fuel tank before transporting over a long distance or on rough roads.

2-4. Stop engine without fail before replenishing fuel tank.

Never replenish gasoline while the engine is running or remains hot otherwise spilled or evaporated fuel is liable to catch fire from engine sparks or muffler heat.

Wipe off spilled fuel, if any, before starting engine. Be careful not to spill fuel.

2-5. Keep inflammable way from the vicinity of the exhaust port.

Be careful with gasoline match, straw and other inflammable, since the exhaust port is subjected to a high temperature.

7.3 STARTING

Gasoline Engine

3-1. Turn the STOP SWITCH clock-wise to the position "1"(ON) (Fig-3)

3-2. Open the fuel cock. (Fig-4)

3-3. Set the speed control lever 1/3 to 1/2 of the way towards the high speed position. (Fig-5)

3-4. Close the choke lever.

If the engine is warm or the ambient temperature is high, open the choke lever half-way, or keep it fully open.

If the engine is cold or the ambient temperature is low, close the choke lever fully. (Fig-6)

3-5. Pull the starter handle slowly until resistance is felt. This is the "compression" point. Return the handle to its original position and pull swiftly.

Do not pull out the rope all the way.

After starting the engine, allow the starter handle to return to its original position while still holding the handle. (Fig-7)

Diesel Engine

3-6. Turn the throttle lever to START position (open by about 30 degrees) (Fig-5-D)

3-7. Operate Starter

In case of recoil starter

By pulling the starter knob slowly, you will reach such point where resistance become strong (compression point). By pulling it further, you will find a point where resistance is reduced. Return the knob, but slowly return it original. (Fig-7-D)

CAUTION

Do not pull the rope all the way and do not take your hand off the pulled knob but slowly return it original position.

3-8. After starting up the engine, be sure to perform a warm up the engine, be sure to perform a warm up run for 2 to 3 minutes. This should be performed without fail, particularly during winter season.

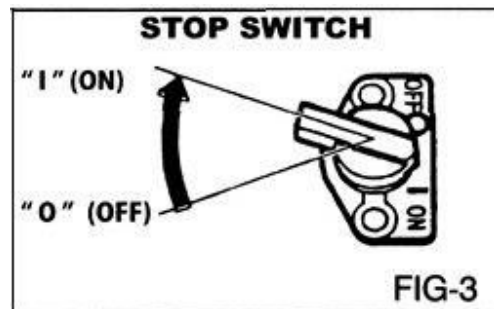

FIG-3

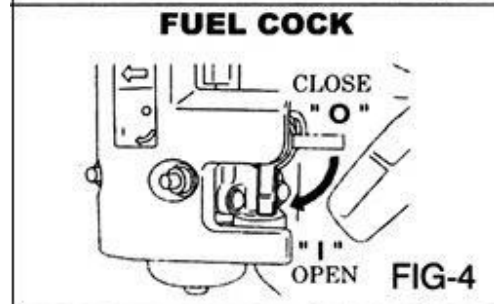

FIG-4



FIG-5

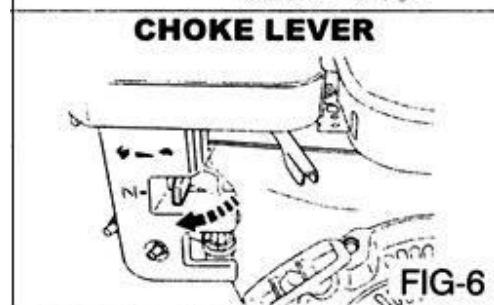

FIG-6

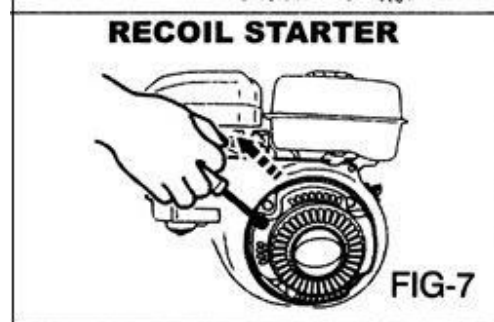

FIG-7

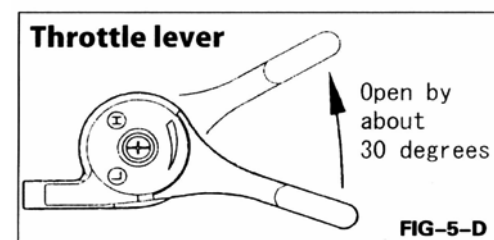

FIG-5-D

7.4 OPERATION

4-1. As the engine warms up, gradually move the choke lever to the **OPEN** position. (Fig-8)

4-2. Move the speed control lever from the **LOW** to the **HIGH** position. When the engine speed reaches approximately 2,300-2,600 PRM, the centrifugal clutch engages. If the engine speed increased very slowly, it is possible that the clutch can slip. Do not operate the speed control lever slowly. (Fig-9,10)

OIL ALERT SYSTEM (Optional)

The Oil Alert system is designed to prevent engine damage caused by an insufficient amount of oil in the crankcase. Before the oil level in the crankcase can fall below a safe limit, the Oil Alert System will automatically stop the engine (the engine switch will remain in the **ON** position).

NOTICE

If the engine stops and will not restart, check the engine oil level.

4-3. When compacting asphalt, it is advisable to paint the bottom face of the vibrating plate with diesel fuel. This will assist in preventing the plate from sticking to the asphalt.

4-4. When shutting off the vibrator, turn the speed control lever from the **HIGH** to **LOW** position. Do not move the speed control lever slowly.

7.5 TRANSPORTATION

5-1. Be sure to stop the engine while transporting.

5-2. Screw up the fuel tank cap securely and close the fuel valve to avoid fuel leaking.

5-3. In transportation by car, fix machine securely not to move nor to fall down.

In case of driving for long distance or at off-road, take out fuel from tank.

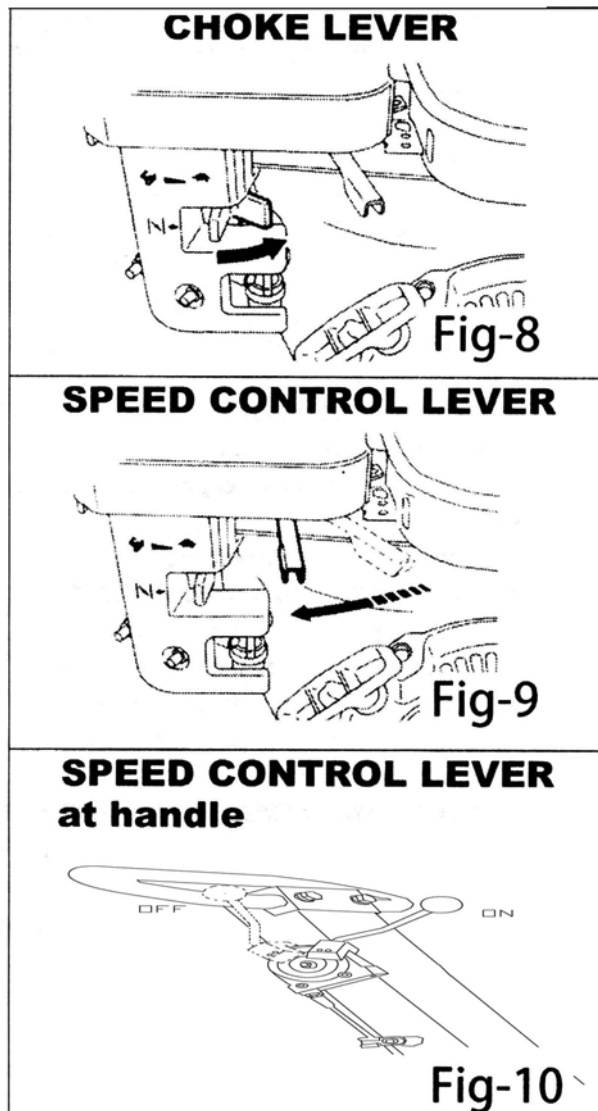

7.6 SHUTDOWN

To stop the engine in an emergency, turn the stop switch to the OFF position.

Under normal conditions, use the following procedure:

6-1. Set the speed control lever at the low speed position and allow the engine to run at low speed for 2 or 3 minutes before stopping.(Fig-11)

6-2.Tum the stop switch to the OFF position.(Fig-12)

6-3.Close the fuel cock. (Fig-13)

7.7 SERVICE&STORAGE

⚠ CAUTION

Flammable liquid: Stop engine and do not smoke or allow work in immediate area when refueling. Fire or explosion could result from flames or sparks.

Moving parts: Shutdown engine before performing service or maintenance. Contact with moving parts can cause serious injury.

High temperature: Allow machine and engine to cool before performing service or maintenance. Contact with hot components can cause serious burn.

7-1. Daily Service

- A. Remove mud, dirt, etc, from the unit.
- B. Clean bottom face of the vibrating plate.
- C. Check the air cleaner element and clean if necessary.
- D. Check all nuts, bolts, and screws for tightness and re-tighten as necessary.

7-2. Weekly Service

A. AIR CLEANER SERVICE (Fig-14)

Dirty air cleaner element will cause starting difficulty, power loss, engine malfunctions, and shorten engine life extremely.

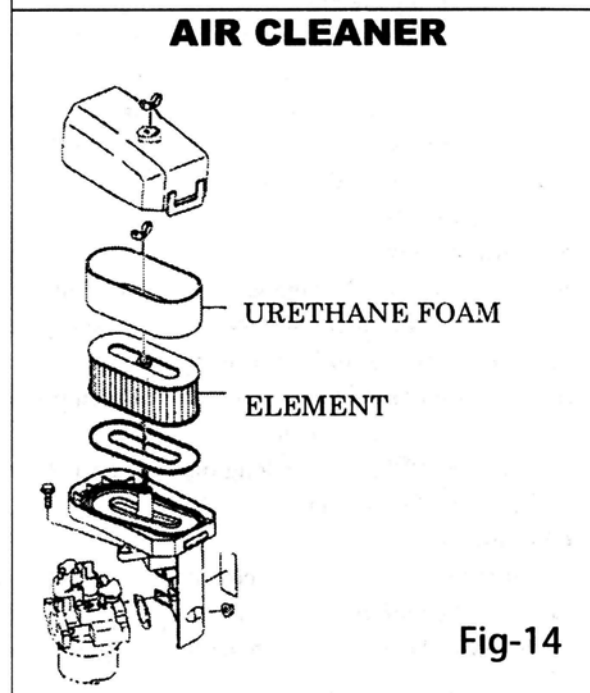
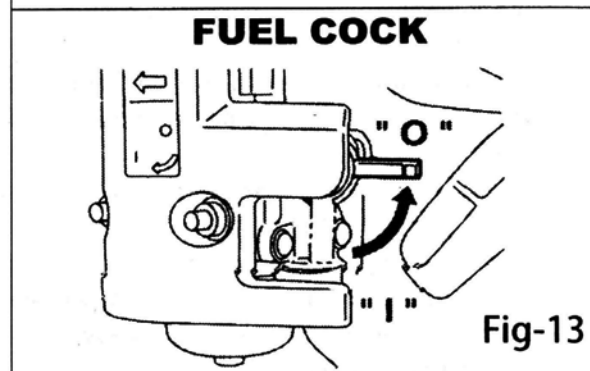
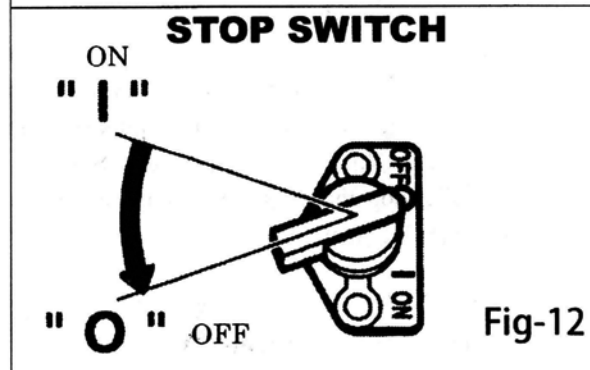
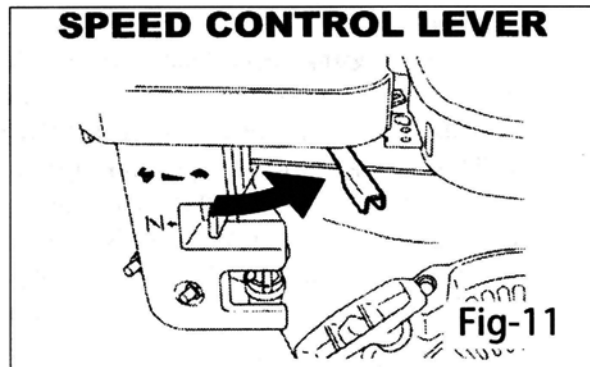

Keep the air cleaner element clean.

URETHANE FOAM ELEMENT

Remove the element and wash it in kerosene or diesel fuel. Then saturate it in a mixture of 3 parts kerosene or diesel fuel and 1 part engine oil. Squeeze the element to remove the mixture and install it in the air cleaner.

URETHANE FOAM DUAL STRUCTURE

1. Clean the urethane foam in the same way as described above.

2. Wash the element in kerosene or diesel fuel. Saturate it in a mixture of 3 parts kerosene or diesel fuel and 1 part engine oil. Shake off excessive oil.

B. Remove spark plug, clean and adjust the spark plug gap to 0.6-0.7mm(0.02-0.03 in.).

(Fig-15)

C. Drain the motor oil of the engine and replace with new specified oil. (Fig-16)



NOTE: When the engine is new, the first oil change must be made after 20 hours of operation and replenish the oil tank before operating.

7-3. Monthly Service

Change the oil in the vibrator assembly.

7-4. Storage

When storing the compactor for long periods after operation.

A. Thoroughly drain the fuel from the fuel tank fuel pipe and carburetor.

B. Pour a few drops of motor oil into the cylinder by removing the spark plug. Rotate the engine several times by hand so that the cylinder interior is covered with oil.

C. Clean the outer surface of the machine with an oil moistened cloth. Cover the unit and store in a humidity-free area.

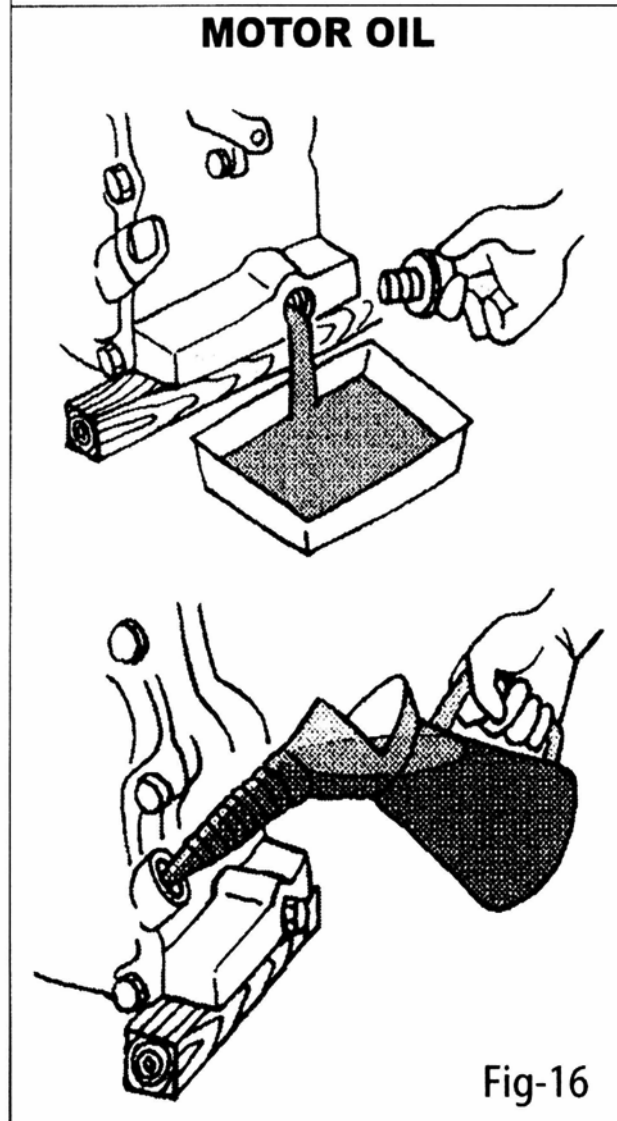
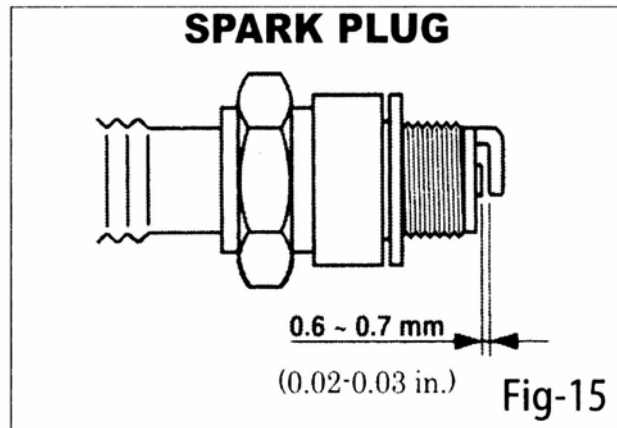

VIII. CARE & PREVENTIVE MAINTENANCE

Check the oil level in the motor crankcase daily. Check the vibrator oil level weekly. Inspect the rubber anti vibration mounts for wear or deterioration. Clean the underside of the plate regularly to prevent a build up of material.

IX. SERVICE

Change the oil in the motor crankcase regularly to minimize wear. Inspect, clean and / or replace the motor air cleaner regularly, particularly when operating in a dusty environment. Inspect, clean and / or replace the spark plug regularly. Check all fasteners for tightness as the machine is subject to vibration. Check V belt tension, wear and that it is running true. Adjust or replace as required.

Vibrator oil check

1. Place the plate compactor horizontally on a flat surface. Make sure the compactor is level when checking the oil in the vibrator assembly.
2. Check vibrator oil level by removing the plug (vibrator oil gauge) as shown in Fig-17.
The oil level should be up to the oil plug. If oil is required, replace using SAE motor oil, as suggested in the table Fig-1.
3. When changing the vibrator oil, remove the drain plug (Fig-17), and simply tip the compactor to drain the oil.
Note that the oil will drain more easily while it is hot.

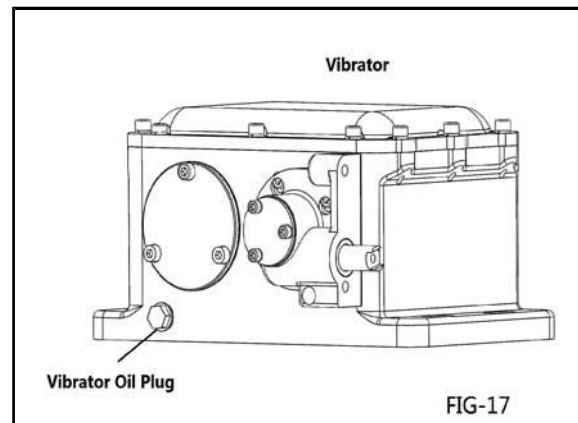

X. TROUBLESHOOTING

| SYMPTOM | POSSIBLE CAUSES AND CORRECTION |
|------------------------------|--|
| Motor will not start | -Check the ON/OFF switch to ensure that it is switched 'ON'. -Check the fuel supply. -If a Honda or Kama motor is fitted check the crankcase oil level as and oil sensor device is fitted to these motors which prevents starting and stops the motor when the oil level is low. -Ensure the carburetor jet and bowl to ensure they are than. |
| Motor stops | -Check the fuel supply. |
| Petrol Motor lacks power. | -Check the condition of the air filter |
| Insufficient vibration | -Check for a slipping or a missing see belt. |
| Machine is not moving freely | -Check the underside of the plate for a build up of material. |

BEARINGS

The following bearings are sealed:

Centrifugal Clutch - grease lubricated

Vibrator - oil bath lubricated

FINISH

The machine is finished in gold equipment enamel, the handle in black backed enamel. Exposed metal surface is zinc electroplated for corrosion protection.

XI. REPLACEMENT PARTS LIST

10.1 MAJOR COMPONENTS

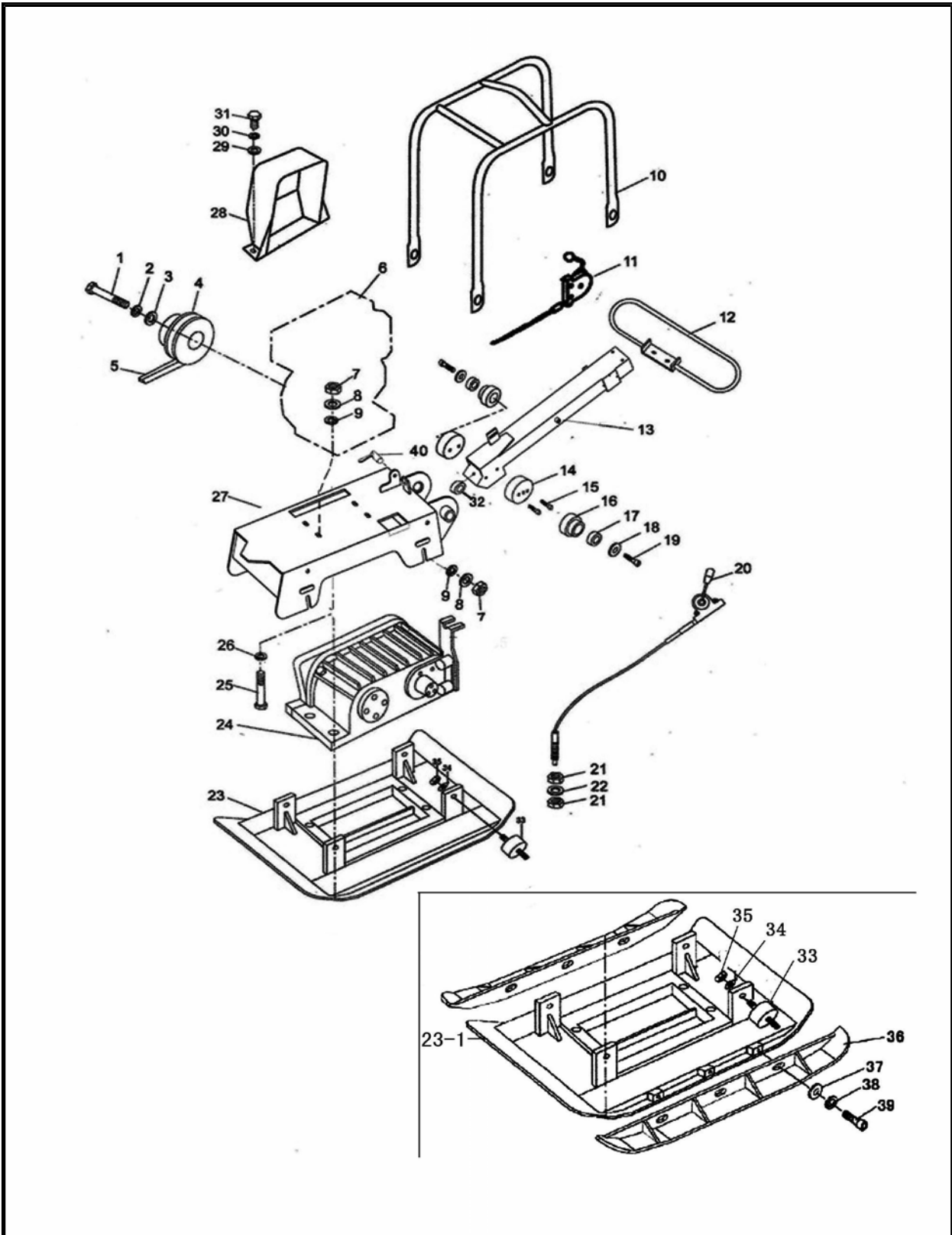

| PART NO. | DESCRIPTION | QTY |
|----------|---|-----|
| 1 | Hex bolt M8*30 | 1 |
| 2 | Spring washer \varnothing 8 | 1 |
| 3 | Bigger flat Washer \varnothing 8 | 1 |
| 4 | Clutch assembly | 1 |
| 5 | Belt | 1 |
| 6 | Engine | 1 |
| 7 | Nut M10 | 4 |
| 8 | Spring washer \varnothing 10 | 4 |
| 9 | Flat washer \varnothing 10 | 4 |
| 10 | Protective frame | 1 |
| 11 | Throttle lever Assy | 1 |
| | Throttle lever | 1 |
| | Throttle cable | 1 |
| 12 | Grip | 1 |
| 13 | Handle | 1 |
| 14 | Shock absorber for handle | 2 |
| 15 | Hex bolt M8*30 | 4 |
| 16 | Nylon liner | 2 |
| 17 | Lining tube | 2 |
| 18 | Bigger flat washer \varnothing 12 | 2 |
| 19 | Hex bolt M12*55 | 2 |
| 20 | Vibrator control Assembly | 1 |
| | Vibrator control lever | 1 |
| | Vibrator control cable | 1 |
| 21 | Nut M16 | 2 |
| 22 | Flat washer \varnothing 16 | 2 |
| 23 | Base plate | 1 |
| 23-1 | Base plate with extension plate (Optional) | 1 |
| 24 | Vibrator assembly | 1 |
| 25 | Hex bolt M12*55 | 4 |
| 26 | Bigger flat washer \varnothing 10 | 4 |
| 27 | Plate for engine mounting | 1 |
| 28 | Belt cover(upper) | 1 |
| 29 | Flat washer \varnothing 8 | 2 |
| 30 | Spring washer \varnothing 8 | 2 |
| 31 | Socket head bolt M8*16 | 2 |
| 32 | Rubber bumper | 1 |
| 33 | Shock absorber for base plate | 4 |
| 34 | Spring washer \varnothing 12 | 4 |
| 35 | Nut M12 | 4 |
| 36 | Extension plate (Optional) | 2 |
| 37 | Flat washer \varnothing 16 | 6 |
| 38 | Spring washer \varnothing 16 | 6 |
| 39 | Hexagonal bolt M16*45 | 6 |
| 40 | Lock, handle | 1 |

10.2 VIBRATOR ASSEMBLY

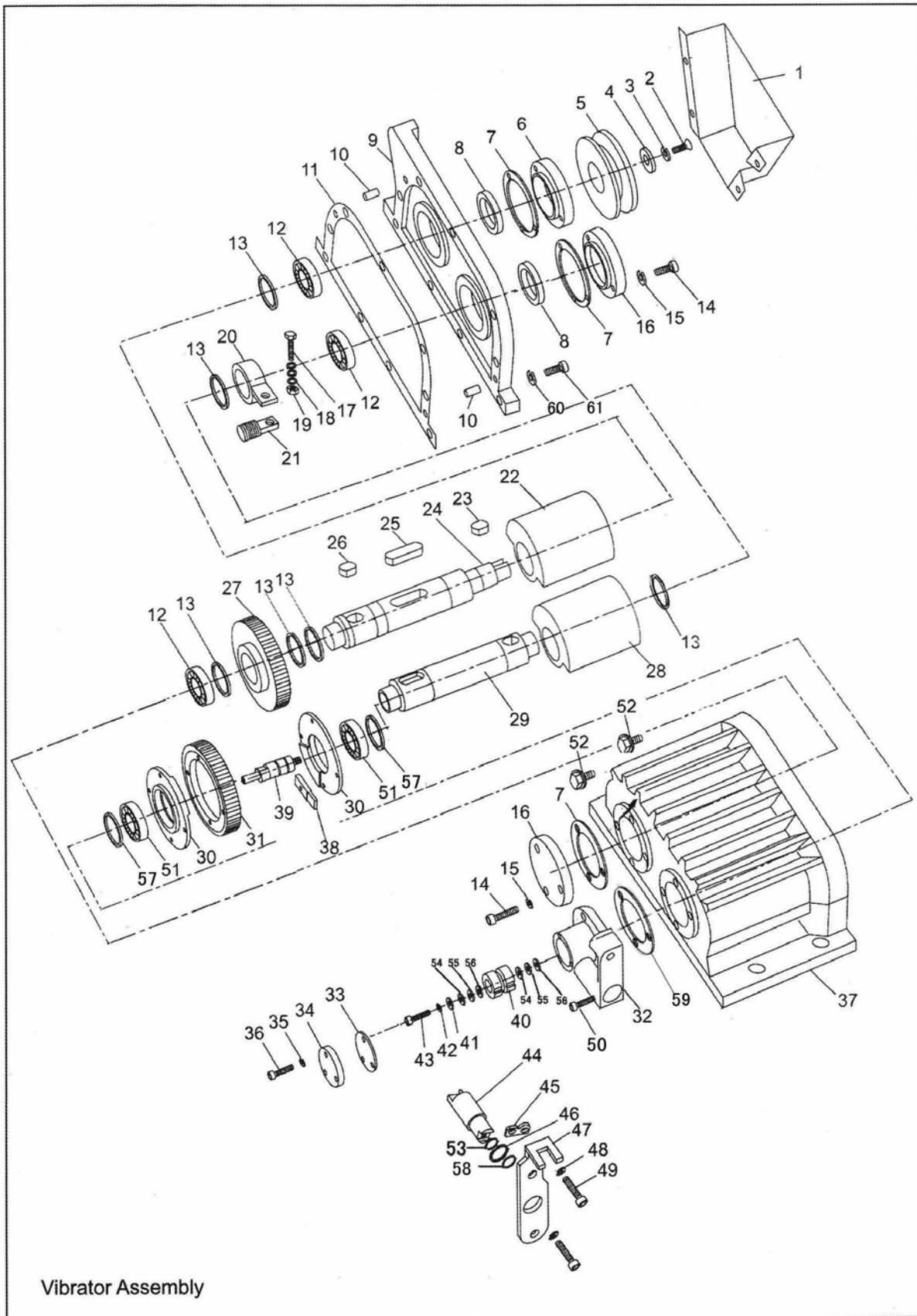

| PART NO. | DESCRIPTION | QTY |
|----------|-------------------------------|-----|
| 24-1 | Belt cover (blow) | 1 |
| 24-2 | Flat screw M8*20 | 1 |
| 24-3 | Washer, lock \varnothing 8, | 1 |
| 24-4 | Wave washer \varnothing 8 | 1 |
| 24-5 | Driven pulley | 1 |
| 24-6 | Bearing cover for pulley | 1 |
| 24-7 | Shim | 3 |
| 24-8 | Oil seal 28*50*10 | 1 |
| 24-9 | Cover of vibrator | 1 |
| 24-37 | Vibrating case | 1 |
| 24-10 | Locating pin \varnothing 8 | 2 |
| 24-11 | Shim | 1 |
| 24-12 | Bearing NJ206 | 4 |
| 24-13 | Circlip \varnothing 42 | 5 |
| 24-14 | Socket head bolt M8*20 | 9 |
| 24-15 | Spring washer \varnothing 8 | 9 |
| 24-16 | Bearing cover / shut-off | 1 |
| 24-17 | Socket head bolt M10*65 | 1 |
| 24-18 | Spring | 1 |
| 24-19 | Nut M10 | 2 |
| 24-20 | Spring clamp | 1 |
| 24-21 | Screw M20, spring clamp | 1 |
| 24-22 | Eccentric rotator, drive | 1 |
| 24-23 | Flat key 8*20 | 1 |
| 24-24 | Ecc. Rotary shaft, drive | 1 |
| 24-25 | Flat key 12*50 | 1 |
| 24-26 | Flat key 12*20 | 1 |
| 24-27 | Gear , drive | 1 |
| 24-28 | Eccentric rotator, driven | 1 |
| 24-29 | Ecc.rotary shaft, driven | 1 |
| 24-30 | Dial plate(R/L) | 2 |
| 24-31 | Gear, driven | 1 |
| 24-32 | Cylinder | 1 |
| 24-33 | Shim | 1 |
| 24-34 | Cover, cylinder | 1 |
| 24-35 | Spring washer \varnothing 6 | 3 |
| 24-36 | Socket head bolt M6*20 | 3 |
| 24-38 | Knock pin | 1 |
| 24-39 | Position rod | 1 |
| 24-40 | Rotary sleeve | 1 |

| PARTNO. | DESCRIPTION | QTY |
|-------------|--------------------------------------|-----|
| 24-41 | Bigger washer \varnothing 5*32*2.5 | 1 |
| 24-42 | Spring Washer \varnothing 5 | 1 |
| 24-43 | Socket head bolt M5*16 | 1 |
| 24-44 | Rotator | 1 |
| 24-45 | Lever, rotator | 1 |
| 24-46 | Oil seal 20*30*6 | 1 |
| 24-47 | Holder | 1 |
| 24-48 | Spring washer \varnothing 10 | 2 |
| 24-49 | Socket head bolt M10*25 | 2 |
| 24-50 | Socket head bolt M8*25 | 4 |
| 24-51 | Bearing 16008 | 2 |
| 24-52 | Oil plug M14*1.5 | 2 |
| 24-53 | O-ring | 1 |
| 24-54.55.56 | Plane bearing | 2 |
| 24-57 | Circlip \varnothing 40 | 2 |
| 24-58 | Clmapspring \varnothing 30 | 1 |
| 24-59 | Shim, cylinder | 1 |
| 24-60 | Washer \varnothing 10 | 9 |
| 24-61 | Socket head bolt M10*30 | 9 |

