

MODEL TMG-MVL22H

STAND-ON MINI TRACK LOADER (22HP HONDA)

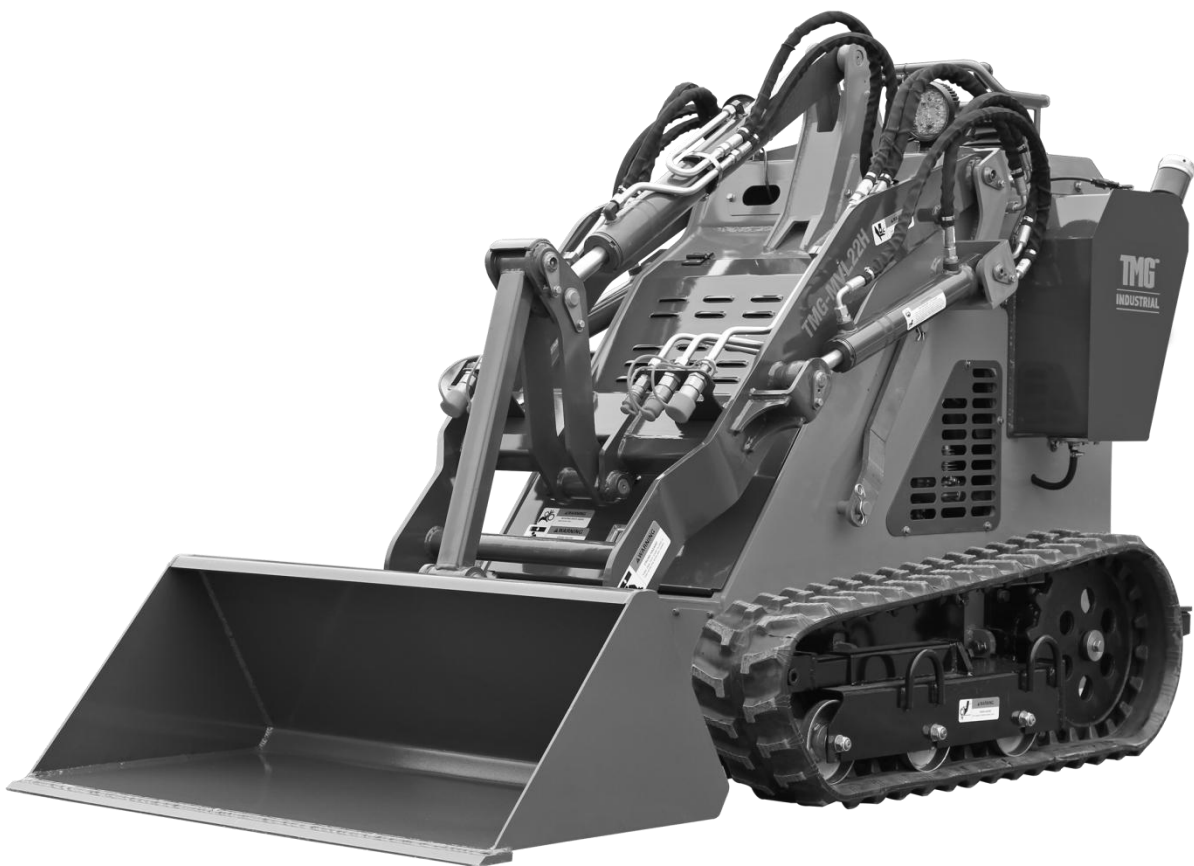

⚠ WARNING

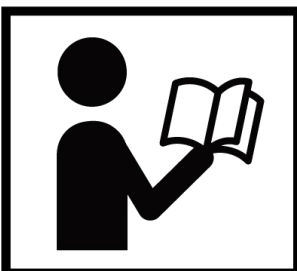

- Please read and understand the product manual completely before assembly
- Check against the parts list to make sure all parts are received
- Wear proper safety goggles or other protective gears while in assembly
- Do not return the product to dealer. They are not equipped to handle your requests.

Missing parts or questions on assembly?

Please call: 1-877-761-2819 or email: cs@tmgindustrial.com

TABLE OF CONTENTS

Intended Use.....	3
Technical Specifications.....	3
Important Safety Information.....	3
Specific Operation Warnings.....	5
Safety and Product Labels.....	8
Before Each Use.....	9
Operating Instructions.....	11
After Each Use.....	16
Maintenance.....	16
Troubleshooting.....	21
Parts Diagram.....	22

Intended Use

This great unit is used for trenching, digging, carrying materials, demolition, site preparation, snow removal, utility installation, sweeping and more, designed for short runs and operation in limited- access spaces.It could be equipped with various attachments for light and medium duty work.

Technical Specifications

Property	Specification
Overall width(with bucket)	1110mm
Overall length	2519mm
Overall height	1405mm
Maximum Operating Height (with standard bucket)	2036mm
Operating weight	1120kg
Rated loading capacity – bucket (with 198lbs operator)	340kg
Travel Speed	0-5km/h
Angle of departure	22°
Engine	22HP
Ground clearance	104mm
System relief pressure (hydraulic)	18MPa
Hydraulic oil tank capacity	33 litres
Standard bucket capacity	0.17CBM
Standard bucket dump height	1312mm
Height to hinge pin	1866mm

* Specifications and design subject to change without notice.

Important Safety Information

WARNING

- Read and understand all instructions. Failure to follow all instructions may result in serious injury or property damage.
- The warnings, cautions, and instructions in this manual cannot cover all possible conditions or situations that could occur. Exercise common sense and caution when using this tool. Always be aware of the environment and ensure that the tool is used in a safe and responsible manner.
- Do not allow persons to operate or assemble the product until they have read this manual and have developed a thorough understanding of how it works.
- Do not modify this product in any way. Unauthorized modification may impair the function and/or safety and could affect the life of the product. There are specific applications for which the product was designed.
- Use the right tool for the job. DO NOT attempt to force small equipment to do the work of larger industrial equipment. There are certain applications for which this equipment was designed. This product will be safer and do a better job at the capacity for which it was intended. DO NOT use this equipment for a purpose for which it was not intended.
- Industrial or commercial applications must follow OSHA requirements.

WARNING

- This product may contain chemicals known to the State of California to cause cancer, birth defects, or other reproductive harm.
- Some dust created by power sanding, sawing, grinding, drilling, and other construction activities contains chemicals known to the State of California to cause cancer, birth defects, or other reproductive harm. Some examples of these chemicals are:
 - lead from lead-based paints,
 - crystalline silica from bricks and cement and other masonry products, and
 - arsenic and chromium from chemically-treated lumber.
- Your risk from these exposures varies, depending on how often you do this type of work. To reduce your exposure to these chemicals: work in a well-ventilated area, and work with approved safety equipment, such as dust masks that are specially designed to filter out microscopic particles.
- Handling power cords on corded products may expose you to lead, a chemical known to the State of California to cause cancer and birth defects or other reproductive harm. Wash your hands after handling.

WARNING

WORK AREA SAFETY

- Inspect the work area before each use. Keep work area clean, dry, free of clutter, and well-lit. Cluttered, wet, or dark work areas can result in injury. Using the product in confined work areas may put you dangerously close to cutting tools and rotating parts.
- Do not use the product where there is a risk of causing a fire or an explosion; e.g., in the presence of flammable liquids, gases, or dust. The product can create sparks, which may ignite the flammable liquids, gases, or dust.
- Do not allow the product to come into contact with an electrical source. The tool is not insulated and contact will cause electrical shock.
- Keep children and bystanders away from the work area while operating the tool. Do not allow children to handle the product.
- Be aware of all power lines, electrical circuits, water pipes, and other mechanical hazards in your work area. Some of these hazards may be hidden from your view and may cause personal injury and/or property damage if contacted.

WARNING

PERSONAL SAFETY

- Stay alert, watch what you are doing, and use common sense when operating the tool. Do not use the tool while you are tired or under the influence of drugs, alcohol, or medication. A moment of inattention while operating the tool may result in serious personal injury.
- Dress properly. Do not wear loose clothing, dangling objects, or jewelry. Keep your hair, clothing and gloves away from moving parts. Loose clothes, jewelry, or long hair can be caught in moving parts. Air vents on the tool often cover moving parts and should be avoided.

- Wear the proper personal protective equipment when necessary. Use ANSI Z87.1 compliant safety goggles (not safety glasses) with side shields, or when needed, a face shield. Use a dust mask in dusty work conditions. Also use non-skid safety shoes, hardhat, gloves, dust collection systems, and hearing protection when appropriate. This applies to all persons in the work area.
- Do not overreach. Keep proper footing and balance at all times.
- Remove keys or wrenches before connecting the tool to an air supply, power supply, or turning on the tool. A wrench or key that is left attached to a rotating part of the tool may cause personal injury.
- Secure the work with clamps or a vise instead of your hand when practical. This safety precaution allows for proper tool operation using both hands.

⚠ CAUTION

PRODUCT USE AND CARE

- Do not force the product. Products are safer and do a better job when used in the manner for which they are designed. Plan your work, and use the correct product for the job.
- Check for damaged parts before each use. Carefully check that the product will operate properly and perform its intended function. Replace damaged or worn parts immediately. Never operate the product with a damaged part.
- Do not use a product with a malfunctioning switch. Any power tool that cannot be controlled with the power switch is dangerous and must be repaired by an authorized service representative before using.
- Disconnect the power/air supply from the product and place the switch in the locked or off position before making any adjustments, changing accessories, or storing the tool. Such preventive safety measures reduce the risk of starting the tool accidentally.
- Store the product when it is not in use. Store it in a dry, secure place out of the reach of children. Inspect the tool for good working condition prior to storage and before re-use.
- Use only accessories that are recommended by the manufacturer for use with your product. Accessories that may be suitable for one product may create a risk of injury when used with another tool. Never use an accessory that has a lower operating speed or operating pressure than the tool itself.
- Keep guards in place and in working order. Never operate the product without the guards in place.
- Do not leave the tool running unattended.

Specific Operation Warnings

⚠ WARNING

- Do not allow any passengers on any part of equipment, including buckets and operating platform.
- Do not refuel with engine running, or while you or someone nearby is smoking.
- Do not operate any of the control levers (including auxiliary lever) unless you are standing with both feet on the platform and firmly holding the grip handles.

- Do not place feet under the platform.
- Watch where you are driving. Always look down and behind, before and while reversing.
- Engine exhaust contains Carbon Monoxide, which is an odourless, deadly poison. Carbon Monoxide can kill you. Do not run engine indoors or in a confined space.
- Always lower loader arms and/or place attachment on the ground when parking or leaving the equipment unattended. Always stop the engine if leaving the operators platform.
- Do not carry a load or heavy attachment with the loader arms in a raised position. Do not step off the platform with a load raised.
- Never jerk the control levers. Use a steady motion. Slow down before turning. Sharp turns may cause loss of control.
- Stop the engine before making any adjustments to the attachments or the machine.
- Never weld on or near the fuel tank whether it is empty full.
- Do not operate on or near embankments. Look out for ditches, holes, etc and beware of traffic when near roads.
- Operate only in daylight or good artificial lighting.
- Do not operate the machine while under the influence of alcohol or drugs.
- Use extra care while loading or unloading the equipment onto a trailer or truck.
- Do not touch equipment or attachment parts that may be hot from operation. Allow to cool before attempting to maintain, adjust or service.
- Do not allow children to play on it.

Operating on slopes:

- Do not operate on slopes exceeding 15°. If the slope is greater than 5° only go up and down (not across).
- Always have the heavy end of the machine uphill. Weight distribution will change. An empty bucket will make the rear of the machine heaviest, a loaded bucket will make the front of the machine heaviest. Various attachments will change which end is heaviest. If you are unsure, phone us and ask. These same rules apply when loading and unloading the equipment onto a trailer or truck.
- Avoid turning on slopes. If you must turn, turn slowly keeping the heavy end of the machine uphill.
- Do not operate near ditches or embankments, the machine could turn over if a wheel goes over the edge of a cliff or ditch or the edge caves in.
- Do not operate on wet grass, reduced traction could cause slip.
- Remove obstacles such as rocks, tree limbs, etc from the work area. Watch for ruts or bumps as uneven terrain could overturn the machine. Tall grass can hide obstacles.
- Operate in slow speed. Put pump selector valve in slow (turtle) position so that you will not have to stop or shift while on the slope.

- If parking on slopes or hillsides always lower the loader arms and attachment to the ground and chock the wheels.
- If machine becomes unstable, jump clear. Never try to stabilize the machine by putting your foot on the ground.

Service:

- Before performing any service, repairs, maintenance or adjustment, stop the engine and remove the key.
- Never run the machine in an enclosed area.
- Perform all maintenance with the loader arms fully lowered. If loader arms need to be raised to perform tasks, secure them in the raised position by using cylinder locks or a safety stand. (Contact us if you are unsure)
- Keep nuts and bolts tight.
- Do not tamper with safety devices. Before each user check safety systems properly.
- Keep the machine free of grass, leaves, or other debris build-up. Clean up oil or fuel spillage. Allow machine to cool before storing.
- Use extra care when handling petroleum and other fuels. They are flammable and vapours are explosive.
 - A. Use only an approved container.
 - B. Never remove the fuel cap or add fuel while the engine is running. Allow engine to cool before refueling. Do not smoke.
 - C. Never refuel the machine indoors.
 - D. Never store the machine or fuel container inside where there is an open flame, such as near a water heater or furnace.
 - E. Never fill a container while it is inside a vehicle, car boot, utility tray or any surface other than the ground.
 - F. Keep container nozzle in contact with the tank during filling.
- Stop and inspect equipment if you strike anything or hear any strange noise coming from the machine. If necessary repair machine before starting again.
- Use only genuine replacement parts to ensure that original standards are maintained.
- Battery acid is poisonous and can cause burns. Avoid contact with skin, eyes, and clothing. Your face, eyes, and clothing should be protected when working with a battery.
- Battery gases can explode. Keep cigarettes, sparks and flames away from battery.
- Hydraulic pressure escaping under pressure can penetrate the skin and cause injury. Keep hands and body away from pin hole leaks or nozzles that eject high pressure hydraulic fluid. A small leak can be dangerous. To find hydraulic leaks, use cardboard or paper. If fluid is accidentally injected into the skin a doctor familiar with this type of injury must surgically remove it within a few hours.

Safety and Product Labels

Reference Number	Description	Quantity
1	Burn Hazard Warning Decal	1
2	Crush Hazard (Hand) Warning Decal	2
3	Crush Hazard (Body) Warning Decal	2
4	High-Pressure Fluid Hazard Warning Decal	3
5	Crush Hazard (Hand, Track) Warning Decal	2
6	Fire Hazard Danger Decal	1
7	Rotating Parts Warning Decal	1
8	Crush Hazard (Body, Access Panel) Warning Decal	1
9	Start-up/Shut-down Instructions Decal	1
10	Operational Warnings Decal	1

⚠ WARNING

BURN HAZARD
Do not touch. Allow surface to cool before servicing.

1

⚠ WARNING

CRUSH HAZARD
Keep hands clear between the arm and frame.

2

⚠ WARNING

CRUSH HAZARD
Keep clear from under bucket or load while the arms are raised.

3

⚠ WARNING

HIGH-PRESSURE FLUID HAZARD

- Inspect hydraulic system regularly for leaks
- Hydraulic fluid escaping through even a pin-sized hole opening can puncture skin and cause blood poisoning
- Wear proper hand and eye protection when searching for leaks.
- Never check for leaks with your hand while system is pressurized. Use wood or cardboard instead of hands
- Relieve pressure on hydraulic system before servicing or disconnecting hoses
- Seek medical attention immediately if injured by escaping fluid

4

⚠ WARNING

CRUSH HAZARD
Shut engine off before servicing track.

5

⚠ DANGER

FIRE HAZARD

- Do not fuel at the work site or while the machine is running
- Refuel loader on a hard, level surface
- Keep open flames and sparks away from the machine while fueling
- Do not smoke while fueling
- Do not fill beyond the overfill marking.
- Expansion of fuel from heat of sun or normal operation may cause tank spillage if overfilled
- Clean up any fuel spills before starting engine

6

⚠ WARNING

ROTATING PARTS INSIDE
Keep hands clear.

7

⚠ WARNING

CRUSH HAZARD
Always install loader safety support and pin securely in place before performing any maintenance or service checks under loader arms. See owner's manual for instructions on use of safety support.

8

Startup

1. Inspect all hydraulic hoses for damage and leaks before each use.
2. Check all operation fluids such as oils before each use.
3. Ensure that the drive control levers and auxiliary hydraulics lever are in the neutral position.
4. Ensure that the throttle lever is in the SLOW position.
5. Turn the ignition key to the "heat" position for 15 seconds.
6. Turn the ignition key to the start position. If the engine does not start, repeat step 5.

Shutdown

1. Park on a hard, level surface.
2. Move the throttle lever to the SLOW position.
3. Lower loader arms to the ground.
4. Ensure that the drive control levers and auxiliary hydraulics lever are in the neutral position.
5. Stop engine by placing ignition key in the OFF position.
6. Cycle the Lift/Tilt control and auxiliary hydraulics levers in all directions until no movement occurs to depressurize hydraulic system.

9

⚠ WARNING	⚠ DANGER	⚠ WARNING	⚠ WARNING
			
IMPACT HAZARD To avoid injury or death caused by falling loads: • Do not handle round bales unless loader is equipped with approved bale handling attachments • Handle raised loads with caution • Carry loads low • Read operator's manual for additional safety information.	ROLLOVER HAZARD Serious injury or death can result from rollovers. • Do not drive on steep slopes. • Carry loader arms and all loads at a low position during transport. • Operate loader at low speeds.	FALL HAZARD To avoid injury from falls: • Do not allow riders on loader or its attachments. • Do not use loader as a work platform.	• To prevent serious injury or property damage, read and understand owner's manual before operating • Always wear the proper protective equipment including ANSI Z87.1 compliant eye protection, hearing protection, steel toe boots, heavy-duty work gloves, and hard hat • Do not exceed the rated load capacity (see owner's manual) • Operate all controls from the operator's position • Keep all safety shields and enclosures in place when operating this equipment • Do not operate around children • Keep all bystanders at least 20 feet away from work area • Follow all shutdown procedures and read manual before servicing

10

Before Each Use

⚠ WARNING

Use a funnel and fill the fuel tank outdoors, in an open area, when the engine is cold.

Clean up any petrol spills.

Do not completely fill the fuel tank. Follow guidelines above.

Never smoke while handling fuels, and stay away from an open flame or any place that a spark may ignite petroleum fumes.

Store fuels in an approved container, out of reach from Children. Never buy more than a 30-day supply of fuel.

Read this manual and the engine manual. Always check the following before operation:

Fuel level;

Ensure breather on top of the fuel cap is open;

Engine oil level (refer to engine manual);

Remove all refuse from the machine;

Be sure that the work area is free from other people and children;

Clear debris in work area. Know and mark the location of any utility lines.

Adding Fuel:

Labelling on the fuel tank tells whether a machine requires petroleum or diesel fuel. For fuel types and information on suitable additives refer to Engine Manual as supplied (NB if labeling becomes lost or damaged or you do not have either Manual, order replacements from your nearest representative or head office).

Filling the fuel tank:

Position machine on level surface, lower the loader arms and turn off the engine (turn ignition key to off). Remove the key.

1. Clean around the fuel tank cap and remove the cap. Use a funnel to add fuel as specified above to the fuel tank, filling until the fuel reaches 60-70mm below the top of the tank. This space is needed to allow the fuel to expand. Do not fill the fuel tank completely full.
2. Replace the fuel cap securely. Clean away any fuel that may have spilt.

Checking oil level:

Refer to your engine manual.

Remove debris from the machine:

IMPORTANT: Overheating will result if the engine is operated with a blocked grass screen, dirty or plugged cooling fins, and/or cooling shrouds removed.

Park the machine on a flat surface, lower the loader arms and turn off the engine (turn ignition key to off). Remove the key.

Check the air filter precleaner for debris. If required, wipe away debris before and during each use.

Debris can build up in the engine area. Clean any debris build-up with a brush or blower before each use.

IMPORTANT: It is preferable to blow out dirt than to wash it out. If water is used, keep it away from electrical appliances.

IMPORTANT: Do not high-pressure wash. High-pressure washing can damage the electrical system.

Check hydraulic fluid:

Check the hydraulic fluid level before engine is started and after every 25 hours of operation.

Fluid type: H46 or equivalent.

Hydraulic tank capacity: 33 litres.

Position machine on level surface. Lower the loader arms and stop the engine.

Clean area around filler neck of hydraulic tank.

1. Remove cap from filter neck and check fluid level. Fluid level should be approximately 75-100mm below the top of the tank.
2. If level is low, add enough fluid to rise to proper level.
3. Install cap on filler neck.

Pre-Start Inspection

It is very important to do a visual inspection of the machine before beginning operation. This inspection should include:

- Check all decals and warning signs for damage.
- Check engine oil.
- Check and refill fuel tanks.
- Check hydraulic lines and hoses for signs of damage or leaks.
- Inspect the machine for any signs of damage or loose fasteners.
- Check fluid levels and any signs of leaking fluid.
- Do all Daily Service Checks.
- Check machine controls to make sure that they automatically return to the neutral position. The following information presents details on these inspection points and service checks.

Activity	Daily (10 Hours)
Fuel	Check and fill
Engine Oil	Check and fill if low
Engine Oil Filter	Inspect for leaks
Engine Radiator	Inspect add if necessary
Air Filter	Check air filter dirt release
Fuel Filter	Inspect for leaks
Battery	Inspect terminals/leaks
Hydraulics - Hydraulic Filter - Hydraulic Fluid - Hydraulic Hoses	Inspect for leaks Check and fill if low Inspect for leaks
Grease	Check*
Track Damage	Inspect
Visual Check for Loose/Missing Fasteners	Inspect
Check and Adjust Track Tension	Inspect
Check both Track Widening Stop Bolts	Inspect

Operating Instructions

WARNING

- Do not operate any of the control levers (including auxiliary lever) unless you are standing with both feet on the platform and firmly holding the grip handles.
- Do not operate or drive machine on roadways.



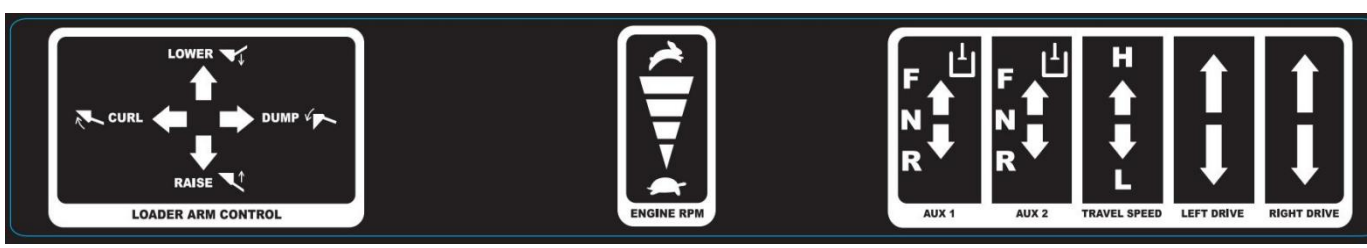
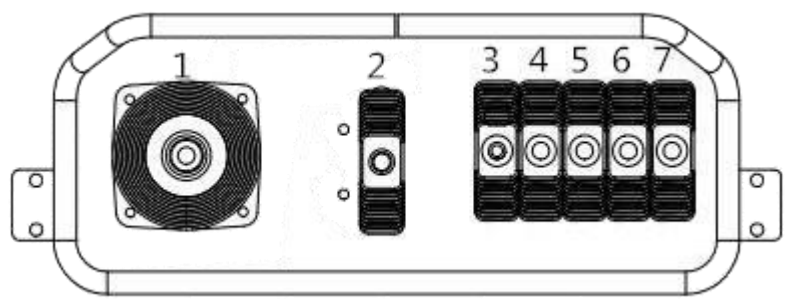

Read all the safety instructions and the pre start up section of this manual and the engine manual before operating the equipment.

IMPORTANT: Ensure the auxiliary hydraulic lever is in centre position before attempting to start engine. The most common cause of “hard to start / engine will not turn over fast enough / battery does not have enough power’ type starting problems is that the auxiliary lever has been left on or knocked into gear and the engine is trying to start under load. Ensure auxiliary lever is in centre position before starting engine.

Drive Control Levers:



Lift/Tilt Control Lever (Lever 1)

-  Forward.....tilt attachment forward
-  Back.....tilt attachment backward
-  Left.....raise the loading arm
-  Right.....lower the loading arm

Throttle Lever (Lever 2):

Push forward to increase engine RPM, Pull backwards to reduce engine RPM

Auxiliary Hydraulics Lever(Lever 3/4);

The auxiliary hydraulic lever is to allow you to alter the direction of rotation of hydraulic driven attachments or stop them completely.

You could choose either Lever 3 or Lever 4 to operate if there is no motor or only one motor on the attachment.

If there are 2 motors on the attachment, operate Lever (3) and (4) together at the same time to alter the direction of attachments.

Driving speed Select Lever (Lever 5):

Push forward to select high speed. Push backwards to select low speed.

Drive control levers (Lever 6, 7):

- To move forward, Push the drive control levers (6), (7) forward. To move rearward, pull the drive control levers (6), (7) rearward.
- To go straight,move both (6) and (7) drive control levers equally.
- To turn, decrease pressure on the drive control lever closest to the direction you want to turn. The farther you move the drive control levers in either direction, the faster the machine will move in that direction.
- To slow or stop, move or release the drive control levers (6), (7) into neutral. (If released the control levers should automatically return to neutral).

Spin Turn

CAUTION: Make sure to use the machine hand holds while doing a spin turn to maintain your balance.Move the control control levers in opposite directions to spin the machine on it axis.

To spin left, move the right control lever forward while pulling the left control lever backward; to spin turn to the right, push the left control lever forward while pulling the right control lever backward.

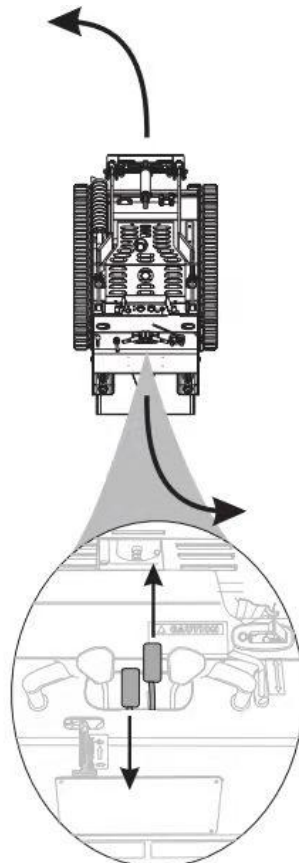

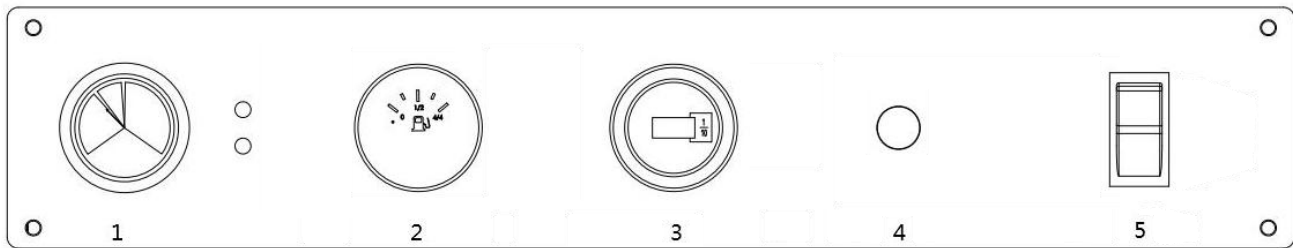

Instrumental Panel

- | | |
|-------------------------|------------------------------|
| 1. FUEL PRESSURE GAUGE | 2. FUEL GAUGE |
| 3. VOLTAGE METER | 4. ENGINE OIL PRESSURE LIGHT |
| 5. WORKING LIGHT SWITCH | |

(1) FUEL PRESSURE GAUGE

When the pointer is in green range, it is normal. When the pointer is in red range, stop the loader and replace oil return filter.

(2) FUEL GAUGE

It shows the fuel level. When it is in red range, it shows fuel insufficient. Then stop the engine and refuel.

(3) VOLTAGE METER

It shows the battery voltage. When the display quantity is less than 11V, the battery needs to be charged or replaced

(4) ENGINE OIL PRESSURE LIGHT

When engine oil pressure is too low, the light will be on. Stop the loader and shut off the engine, find out the trouble. Do not operate the machine until the trouble is cleared.

(5) WORKING LIGHT SWITCH

Press the switch and light will turn on.

Starting and stopping the Engine

Starting

Stand on the platform.

Move the auxiliary hydraulics lever to neutral.

ATTENTION: Ensure auxiliary hydraulic lever is in neutral position before starting engine. Aside from starting difficulties the attachment may move during starting.

Follow instructions on starting engine as detailed in the engine manufacturers manual.

Stopping

Move the throttle lever to "slow".

Lower loader arms to the ground.

Turn the ignition key to off.

Note: If the engine has been working hard or is hot, let it idle for a minute before turning the ignition key "OFF". This helps cool the engine before it is stopped. In an emergency, turning the ignition key to "OFF" will stop the engine.

Attachments

Connecting

IMPORTANT: Use only manufacturer approved attachments. Attachments could change stability and operating characteristics of the machine. The warranty of the machine may be voided if used with unapproved attachments.

IMPORTANT: Before connecting any attachments to the machines, make sure mount plates are free of any dirt and debris.

1. Move speed control lever to slow (turtle) position.
2. Slowly push the attachment tilt lever forward to tilt the attachment mount plate forward.
3. Position mount plate into the upper lip of the attachments receiver plate.
4. Raise the loader arms while tilting back the mount plate at the same time.

IMPORTANT: The attachment should be raised enough to clear the ground and the mount plate tilted all the way back.

5. Turn the ignition key to "OFF" to stop the engine.
6. Engage the attachment lock pins.

Note: Lock pins are located on the operator side of the mount plate and should be turned toward the inside to engage.

Note: Proceed to next step if auxiliary hydraulics are required with attachment.

IMPORTANT: Make sure all foreign matter is cleaned from hydraulic connections before making connections.

7. Move the auxiliary hydraulics lever to the forward, backward, and back to neutral position to relieve hydraulic pressure at the hydraulic couplers.
8. Remove protective covers from the hydraulic couplers on machine. Connect covers together to prevent contamination during operation.
9. Confirm that connection is secure by pulling on the hoses.

Disconnecting

1. Lower attachment onto a firm, level surface.
2. Shut off the machine engine
3. Move the auxiliary hydraulics lever forward, backward and back to normal position to relieve hydraulic pressure at the hydraulic couplers.
4. Slide collar back on the hydraulic coupler and disconnect attachment couplers from machine couplers. (Note: if this is difficult return to step 3 and repeat.)

IMPORTANT: Connect attachment hoses together to prevent contamination during storage.

5. Install protective covers onto machines hydraulic couplers.
6. Disengage the attachment lock pins by turning them to the outside.
7. Start engine, tilt the mount plate forward and back machine away from attachment.

After Each Use

⚠ WARNING

- Move all controls to neutral position when stopped.
- Load and unload trailer on level ground.

Transporting and securing

IMPORTANT: When transporting machine on a trailer, always use the following procedure.

1. Lower the loader arms.
2. Turn the ignition key to “OFF” to stop the engine.
3. Secure the machine to the trailer with chains or straps using the rear platform support openings to secure of machine and loader arms/mount plate to secure front of machine.

CAUTION! If children or bystanders attempt to operate the machine, someone could be injured. To avoid attempted use by children or bystanders while machine is unattended, remove the key from the ignition, even if just for a few minutes.

Moving a Non-functioning machine

IMPORTANT: Never tow the machine because hydraulic damage may occur.

1. Turn the ignition key to “OFF” to stop the engine.
2. Lift the entire machine off the ground and move the machine.

Maintenance

⚠ WARNING

- Keep your tool in good repair.
- Keep all cutting tools sharp and clean. Properly maintained cutting tools with sharp cutting edges are less likely to bind and are easier to control.
- Keep handles dry, clean, and free from oil and grease.

Maintain the product by adopting a program of conscientious repair and maintenance in accordance with the following recommended procedures. It is recommended that the general condition of any tool be examined before it is used. Also refer to the engine manufacturer’s instruction manual for additional information about engine maintenance. The following chart is based on a normal operation schedule.

Maintenance Interval	Maintenance Point
Every 25 hours	<ol style="list-style-type: none"> 1. Check hydraulic oil level and check for external leaks; 2. Service pre-cleaner element (1); 3. Check bushes & replace if required; 4. Check engine oil level.
Every 50 hours	<ol style="list-style-type: none"> 1. Check hydraulic oil level and check for external leaks; 2. Check hydraulic hoses and tighten if required; 3. Replace air cleaner & clean pre-cleaner); 4. Check of fuel pipes and clamp bands; 5. Check engine oil level
Every 100 hours	<ol style="list-style-type: none"> 1. Change engine oil & filter; 2. Test all functions in operation; 3. Check – clean spark plug (s); 4. Replace fuel filter; 5. Replace air cleaner element); 6. Remove cooling shrouds and clean cooling area's; 7. Check oil cooler fins, clean as necessary.
Every 500 hours	<ol style="list-style-type: none"> 1. Change hydraulic fluid; 2. Change hydraulic filter; 3. Remove sediment in fuel tank.

It is recommended that some parts be kept on hand for maintenance purposes at all times. The following pack is excellent value, being considerably cheaper than purchasing the parts individually. Please phone us for current pricing of this kit. It may be necessary to add to this kit depending on what attachments you may have.

Bushes:

1. The equipment has 10 Duralon bushes and chrome pines. These are located on either end of your hydraulic cylinders and on all pivot points of the lift arms.
2. These bushes are wear part and require regular inspection. It is essential that these bushes be replaced on the first sign of wear, otherwise costly damage will occur.
3. You should ensure that spare bushes are on hand at all times.

Engine Oil

Refer to Engine Manual for required frequencies of oil changes, oil types, crankcase capacity, and viscosity.

Changing/ Draining oil

1. Start the engine and let it run for 5 minutes. This warms the oil so it drains better.
2. Park the machine so the drain side is slightly lower than then opposite side to assure that the oil drains completely. Then lower the loader arms, chock the wheels and turn the ignition key to "OFF" to stop then engine. Remove the key.
3. Place the end of the hose in a pan. Remove bung by turning counter clockwise while holding the nut. Allow to drain.
4. When oil has drained completely, replace the bung.

Note: Dispose of used oil in accordance with local authority regulations.

5. Slowly pour approximately 80% of the specified amount of oil (refer to engine manual) into the filter tube. Now check the oil level. Slowly add additional oil to bring to "FULL" mark on dipstick.

Changing Oil Filter

Refer to engine manual.

Spark Plug(s)

Removing and checking Spark Plug (Petrol Only)

Refer to engine manual

Fuel Filter

Replace the fuel filter after every 100 operating hours or yearly, whichever occurs first.

Replacing the Fuel Filter

1. Never re-install a dirty filter.
2. Lower the loader arms and turn the ignition key to "OFF" to stop the engine. Remove the key.
3. Clamp fuel line between fuel tank and fuel filter to block fuel flow.
4. Squeeze the ends of the hose clamps together and slide them away from the filter.
5. Place a drain pan under the fuel lines to catch any leaks, then remove the filter from the fuel lines.
6. Install a new filter and move the hose clamps close to the filter.
7. Remove clamp blocking fuel flow.

Fuel Tank

Draining the fuel tank.

Drain the diesel oil from the fuel tank when the engine is cold. Do this outdoors in an open area. Wipe up any oil that spills.

- Never drain the oil near an open flame or where a spark may ignite fumes.
- Never smoke while handling fuel.

1. Park the machine on a level surface, to assure fuel tank drains completely. Then lower the loader arms and turn the ignition key to "OFF" to stop the engine. Remove the key.
2. Loosen the hose clamp at the fuel filter and slide it up the fuel line away from the fuel filter.
3. Pull the fuel line off the fuel filter, open the fuel valve, and allow gasoline to drain into a gas can or drain pan.
4. Remove tank from the machine by undoing nut at clamp at top of tank. Remove tank, drain completely and flush by tipping tank upside down.
5. Reverse procedure to replace clean tank.

Note: Now is the best time to install a new fuel filter because the fuel tank is empty.

6. Install the fuel line onto the fuel filter. Slide the hose clamp close to the fuel filter to secure the fuel line.

Hydraulic system

Replacing the Hydraulic filter

Change the hydraulic filter: **After every 500 operating hours.**

- Never replace the hydraulic oil filter when the oil is still hot.
- Used oil filters should be collected in accordance with local regulations.

Replace the hydraulic oil filter in the following steps:

1. Raise the loader arms and install the safety support, stop the engine, and remove the key.
2. Open the oil tank flange to release the remaining pressure inside the tank
3. Screw off the oil filter.
4. Installing a new filter and tighten it clockwise until it is fastened well.
5. Close the oil tank flange.

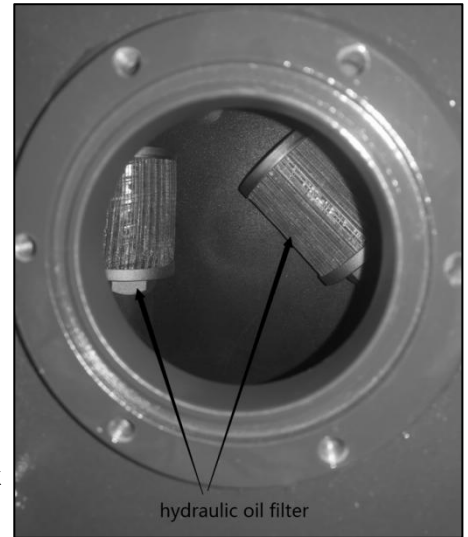

Changing the Hydraulic Fluid

Change the hydraulic fluid: **After every 500 operating hours**

1. Position the machine on a level surface, lower the loader arms and turn the ignition key to “OFF” to stop the engine. Remove the key.

IMPORTANT: Do not substitute automotive oil filter or severe hydraulic damage may result.

2. Place large drain pan under the machine that can hold at least 70 liters.
3. Remove the drain plug from the bottom of the hydraulic tank and allow the fluid to completely drain out.
4. Remove the tank top and wipe out the inside of the tank. Note if any foreign objects are there. If anything unusual is found, consult your service centre or a hydraulic expert.
5. Install the drain plug.
6. Fill the hydraulic tank with approximately 33 liters of H68 Hydraulic oil. Note: Dispose of used oil in accordance with local authority regulations.

Check hydraulic lines

After every 100 operating hours, check hydraulic lines and hoses for leaks, loose fittings, kinked lines, loose mounting supports, wear, weather and chemical deterioration. Replace all moving hydraulic hoses every 1500 hours or two years, whichever comes first. Make necessary repairs before operating.

WARNING!

Hydraulic pressure escaping under pressure can penetrate the skin and cause injury.

Keep hands and body away from pin hole leaks or nozzles that eject high pressure hydraulic fluid. A small leak can be dangerous. To find hydraulic leaks, use cardboard or paper.

If fluid is accidentally injected into the skin a doctor familiar with this type of injury must surgically remove it within a few hours.

Battery

Always keep the battery clean and fully charged. Use a paper towel to clean the battery case. If the battery terminals are corroded, clean them with a solution of four parts water and one part baking soda. Apply a light coating of grease to the battery terminals to reduce corrosion.

Voltage: 12V, 380 Cold Cranking Amps.

If battery becomes flat or machine is not used for a long period, charge the battery using an external battery charger. Do not rely on the engine's charging system to recharge a battery. It is only meant to maintain charge in a good battery.

Cleaning and long term storage

1. Lower the loader arms and turn the ignition key to "OFF" to stop the engine. Remove the key.
2. Remove dirt and grime from the external parts of the entire machine, especially the engine. Clean dirt and chaff from the outside of the engine's cylinder head fins and blower housing.

IMPORTANT: You can wash the machine with mild detergent and water. Do not pressure wash the machine. Avoid excess use of water, especially near the control panel, engine, hydraulic pumps and motors.

3. Service the air cleaner; refer to section on Air Cleaner.
4. Change the crankcase oil; refer to engine manual.
5. Petrol machines only: remove the spark plug (s) and check its condition; refer to section on Spark Plugs. With spark plug(s) removed from the engine, pour two tablespoons of engine oil into the spark plug hole. Now use the starter to crank the engine and distribute the oil inside the cylinder. Install the spark plug(s). Do not install the wire on the spark plug(s).
6. Charge the Battery; refer to section on Batteries.
7. For long-term storage (more than 90days) add stabilizer/conditioner additive to fuel tank.
 - A. Run engine to distribute conditioned fuel through the fuel system (5 minutes).
 - B. Stop engine, allow to cool and drain the fuel tank; refer to section on Fuel Tank.
 - C. Restart engine and run it until it stops. Repeat, on "CHOKE" until engine will not restart.
 - D. Dispose of fuel properly. Recycle according to local codes. Note: Do not store stabilizer/conditioned petrol over 90 days.
8. Check and tighten all bolts, nuts, and screws. Repair or replace any part that is damaged or defective.
9. Store the machine in a clean, dry garage or storage area. Remove the key from the ignition switch and keep it in a memorable place. Cover the machine to protect it and keep it clean.

Troubleshooting

Use the table below to troubleshoot problems before contacting service personnel or your local dealer. If the problem continues after troubleshooting, call your local dealer for assistance.

Failure	Possible Cause	Corrective Action
Starter does not crank	1. Battery is dead.	1. Change the battery.
	2. Electrical connections are corroded or loose.	2. Check electrical connections for good contact.
	3. Relay switch is defective.	3. Contact authorized service dealer.
Engine will not start, starts hard, or fails to keep running	1. Auxiliary hydraulics lever is not in neutral position.	1. Move the lever to neutral position.
	2. Fuel tank is empty.	2. Fill fuel tank with gasoline.
	3. Air cleaner is dirty.	3. Clean or replace air cleaner element.
	4. Dirt in fuel filter.	4. Replace fuel filter.
	5. Dirt, water, or stale fuel is in the fuel system.	5. Contact Authorized service dealer.
Engine loses power	1. Engine load is excessive.	1. Reduce ground speed.
	2. Air cleaner is dirty.	2. Clean air cleaner element.
	3. Cooling fins and air passages under engine blower housing are plugged.	3. Remove obstruction from cooling fins and air passages.
	4. Dirt in fuel filter.	4. Replace fuel filter.
	5. Dirt, water, or stale fuel is in fuel system.	5. Contact authorized service Dealer.
	6. Breather on fuel tank is closed.	6. Open breather.
Engine overheats	1. Engine load is excessive.	1. Reduce ground speed.
	2. Cooling fins and air passages under engine blower housing are plugged.	2. Remove obstruction form cooling fins and air passages.
	3. Water level is low (diesel only)	3. Top up water.
Abnormal vibration	Engine mounting bolts are loose.	Tighten engine mounting bolts.
Machine does not drive	2. Hydro fluid level low.	2. Add hydro fluid to reservoir.
	3. Traction pump drive coupler is loose or broken.	3. Contact Service Dealer.
	4. Pump and /or wheel motor is defective or damaged.	4. Contact Service Dealer.
	5. Control valve is defective or damaged.	5. Contact Service Dealer.
	6. Relief valve is defective or damaged.	6. Contact Service Dealer.

Parts Diagram

Part 1: Machine Assembly

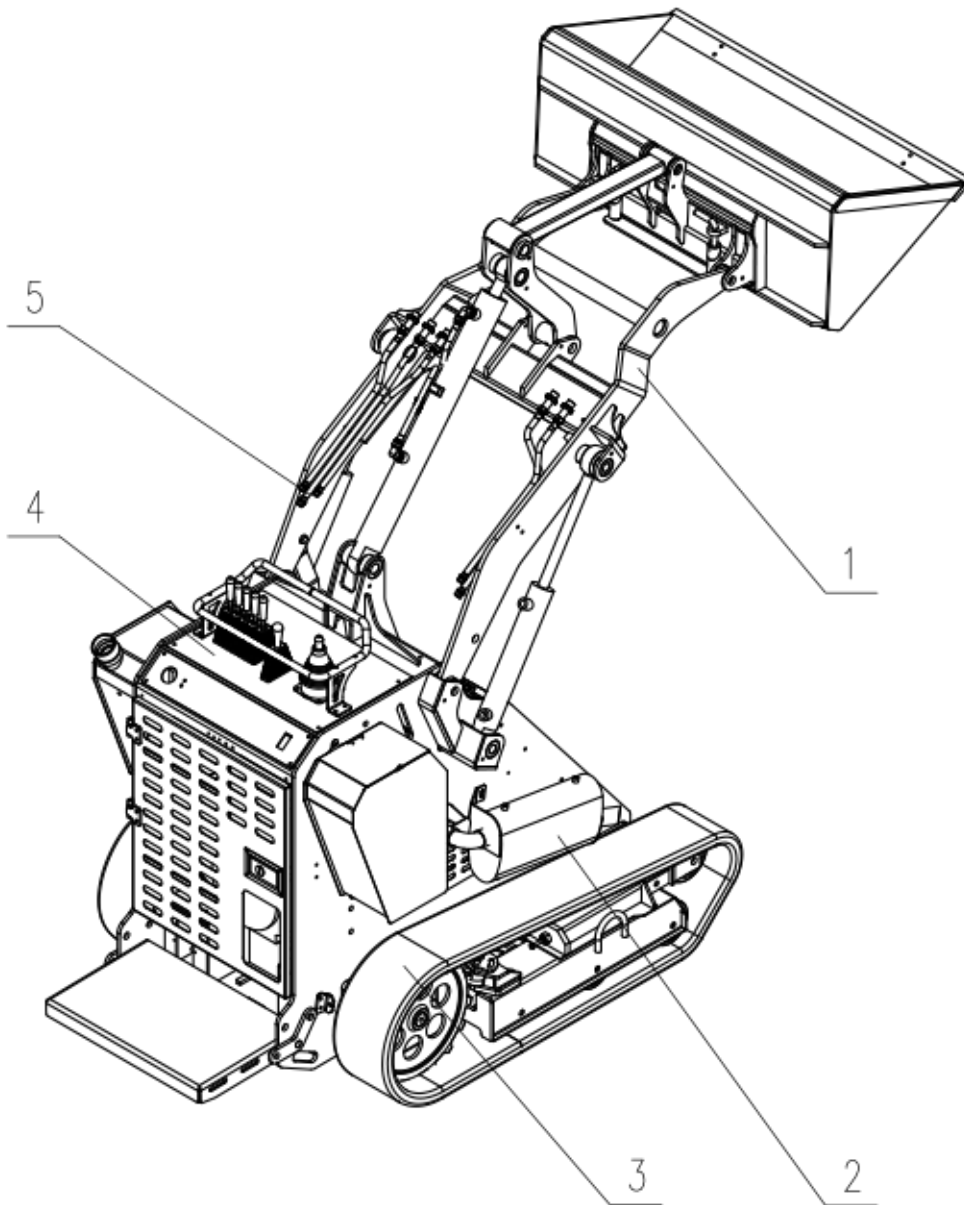

REF NO.	DESCRIPTION	QTY
1	Lifting device assembly	1
2	Power system	1
3	Track walking system	1
4	Lower frame assembly	1
5	Hydraulic system assembly	1

Part 2: Lifting device assembly

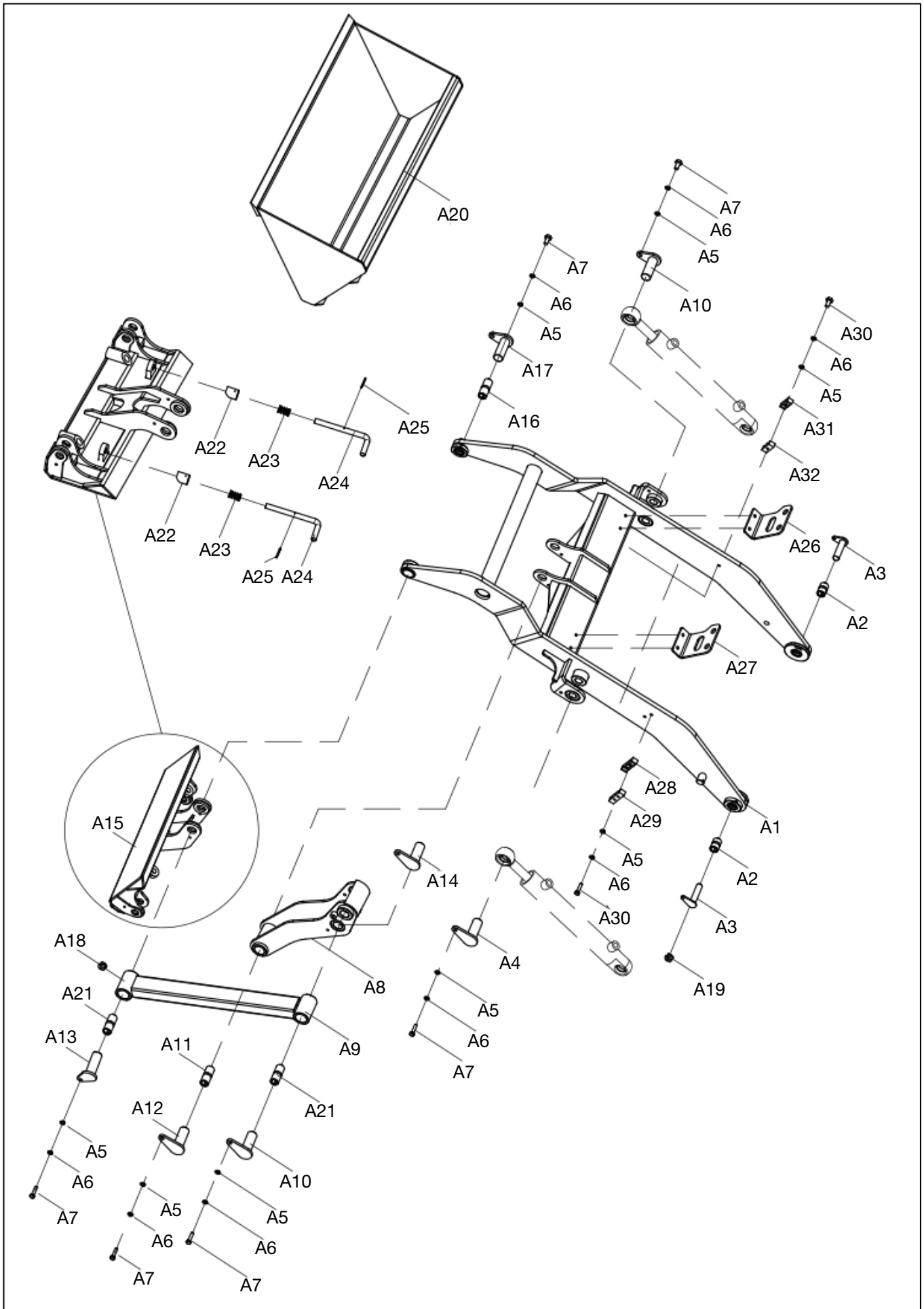

REF NO.	DESCRIPTION	QTY	REF NO.	DESCRIPTION	QTY
A1	Working arm assembly	1	A17	Pylon pin welding assembly	2
A2	Rear working arm bush	2	A18	Oil cup M8x1	3
A3	Working arm pin assembly	2	A19	Oil cup M6	4
A4	Front tilt cylinder pin welding assembly	2	A20	Bucket welding assembly	1
A5	Washer Ø8	13	A21	Pull rod bush	2
A6	Washer Ø8	13	A22	Bush	2
A7	Bolt M8x16	9	A23	Lock spring	2
A8	Rocker arm welding assembly	1	A24	Lock pin	2
A9	Pull rod welding assembly	1	A25	Pin Ø2.5x36	2
A10	Rear rod pin welding assembly	4	A26	Quick connector fixed plate (right)	1
A11	Swing arm bush	1	A27	Quick connector fixed plate (left)	1
A12	Lower rocker arm pin welding assembly	1	A28	Fuel pipe clamp II	1
A13	Front rod pin welding assembly	1	A29	Fuel pipe clamp I	1
A14	Front tilt cylinder pin welding assembly	1	A30	Bolt M8x25	4
A15	Pylon assembly	1	A31	Fuel pipe seat I	1
A16	Pylon bush	2	A32	Fuel pipe clamp III	1

Part 3: Track Walking System

3.1 Track Assembly

REF NO.	DESCRIPTION	QTY	REF NO.	DESCRIPTION	QTY
B1	Track 200x72x41	2	B16	Bolt M14x30	12
B2	Bolt M14x40	32	B17	Chain I 12A-1-72(60-1R-72)	1
B3	Washer Ø14	48	B18	Right right pulley mounting bracket	1
B4	Washer Ø14	16	B19	Hexagon lock nut M16	6
B5	Output assembly IA	2	B20	Washer Ø14	6
B6	Bolt M5x12	6	B21	Washer Ø12	8
B7	Sprocket locknut	2	B22	Screw M12x50	8
B8	Chain I 12A-A-52(60-1R-52)	1	B23	Motor location key	2
B9	Small sprocket	2	B24	Top pillar	2
B10	Left driven pulley mounting bracket	1	B25	Tension spring	2
B11	Nut M18	2	B26	Tension device assembly	2
B12	Bolt M18x50	2	B27	Screw M16x60	2
B13	Hexagon lock nut M16	12	B28	Nut M16	2
B14	Washer Ø16	12	B29	Frame welding assembly	1
B15	Driven pulley assembly	6			

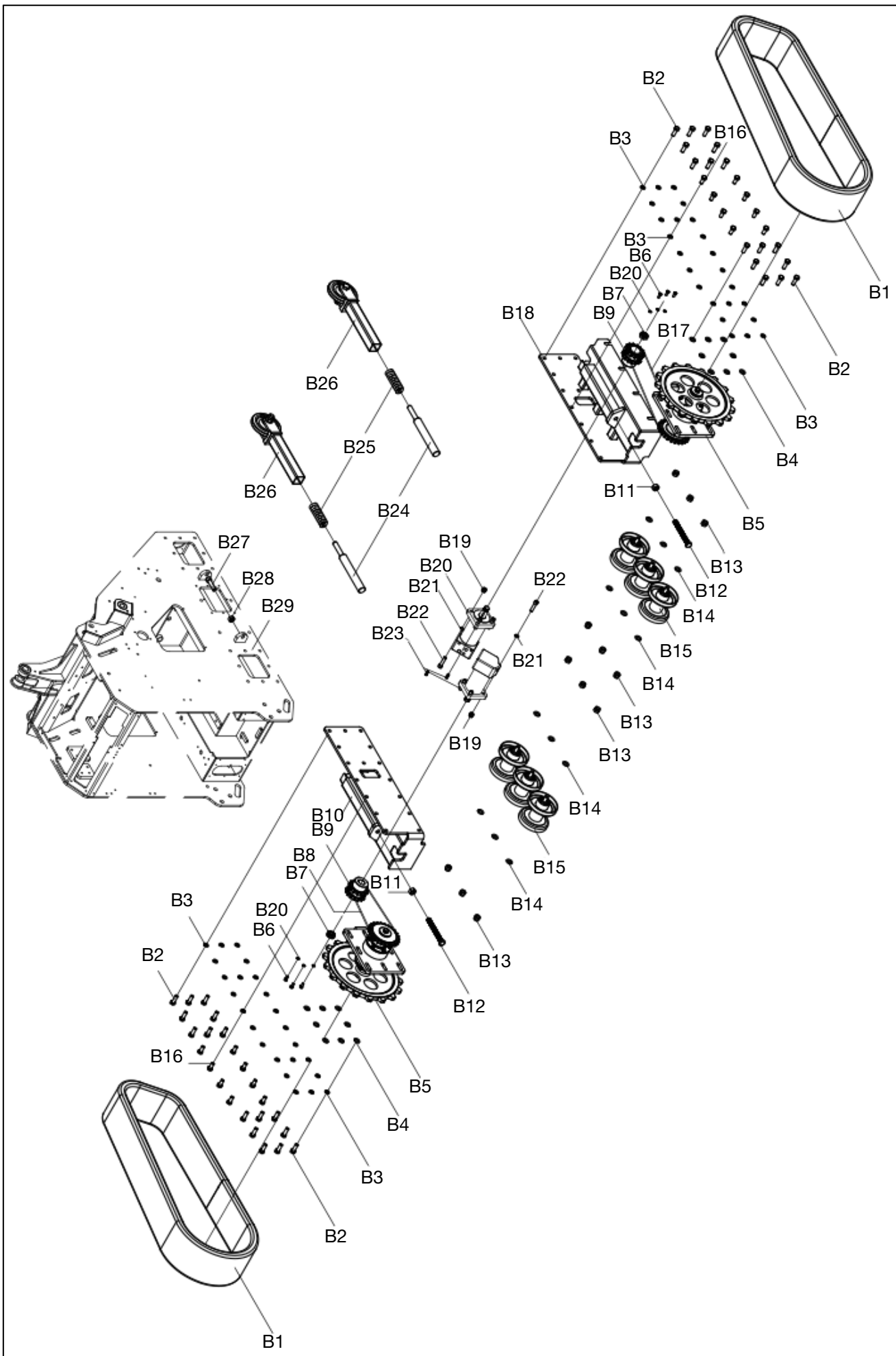

3.2 Drive System

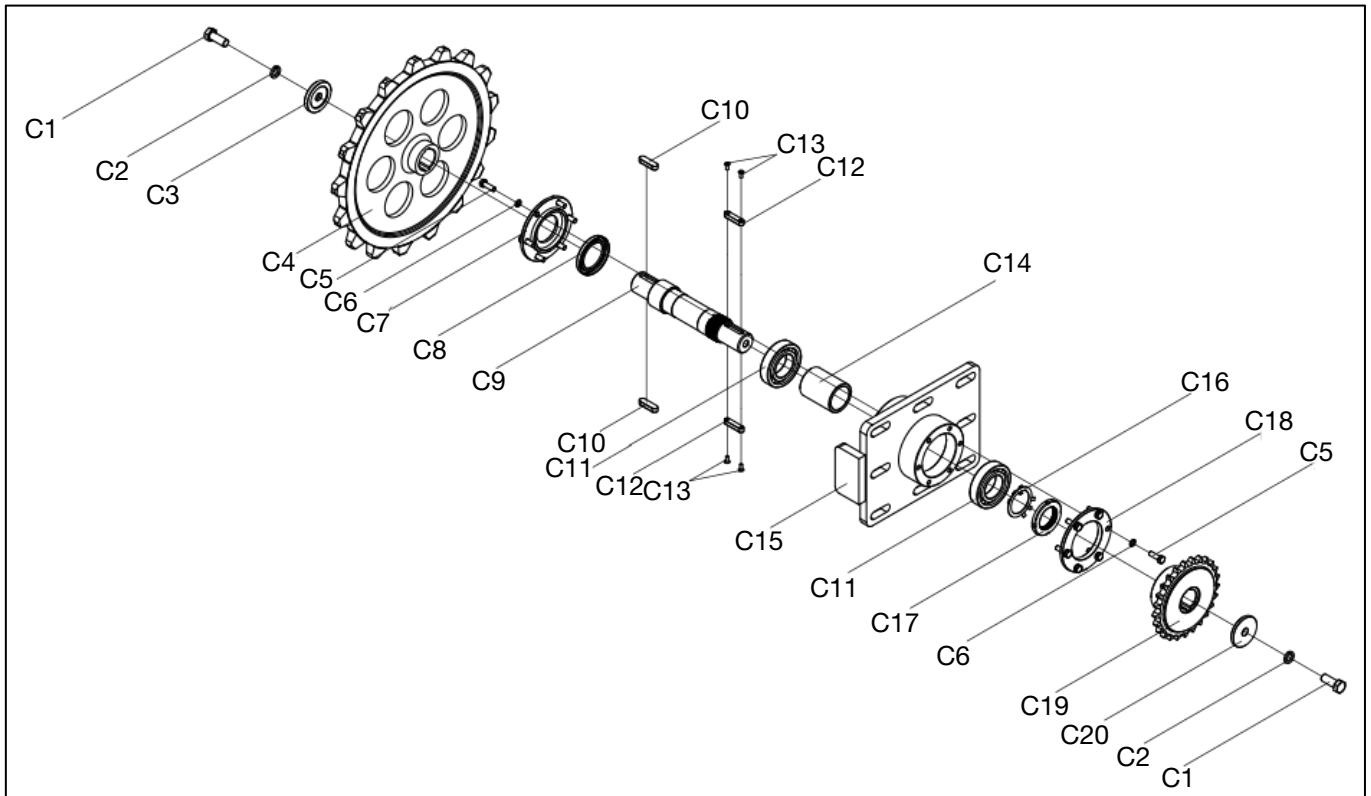

REF NO.	DESCRIPTION	QTY	REF NO.	DESCRIPTION	QTY
C1	Bolt M14x35	4	C11	Bearing 6209-2RS	4
C2	Washer Ø14	4	C12	Large sprocket orientation block	4
C3	Output shaft outer pressure plate	2	C13	Nut M5x12	4
C4	Drive wheel	2	C14	Output shaft sleeve	2
C5	Bolt M8x25	24	C15	Bearing mount	2
C6	Washer Ø8	24	C16	Lock washer	2
C7	Out bearing and cap	2	C17	Round nut M45x1.5	2
C8	Rubber rotary shaft oil seal FB52x75x8	2	C18	Inner bearing end cap	2
C9	Output shaft	2	C19	Large sprocket	2
C10	Wheel orientation block	4	C20	Large sprocket pressure plate	2

3.3 Driven System

REF NO.	DESCRIPTION	QTY	REF NO.	DESCRIPTION	QTY
D1	Washer	16	D4	Driven wheel welding assembly	8
D2	Retainer ring A52	16	D5	Driven wheel axle	8
D3	Bearing 6205-2RS	16			

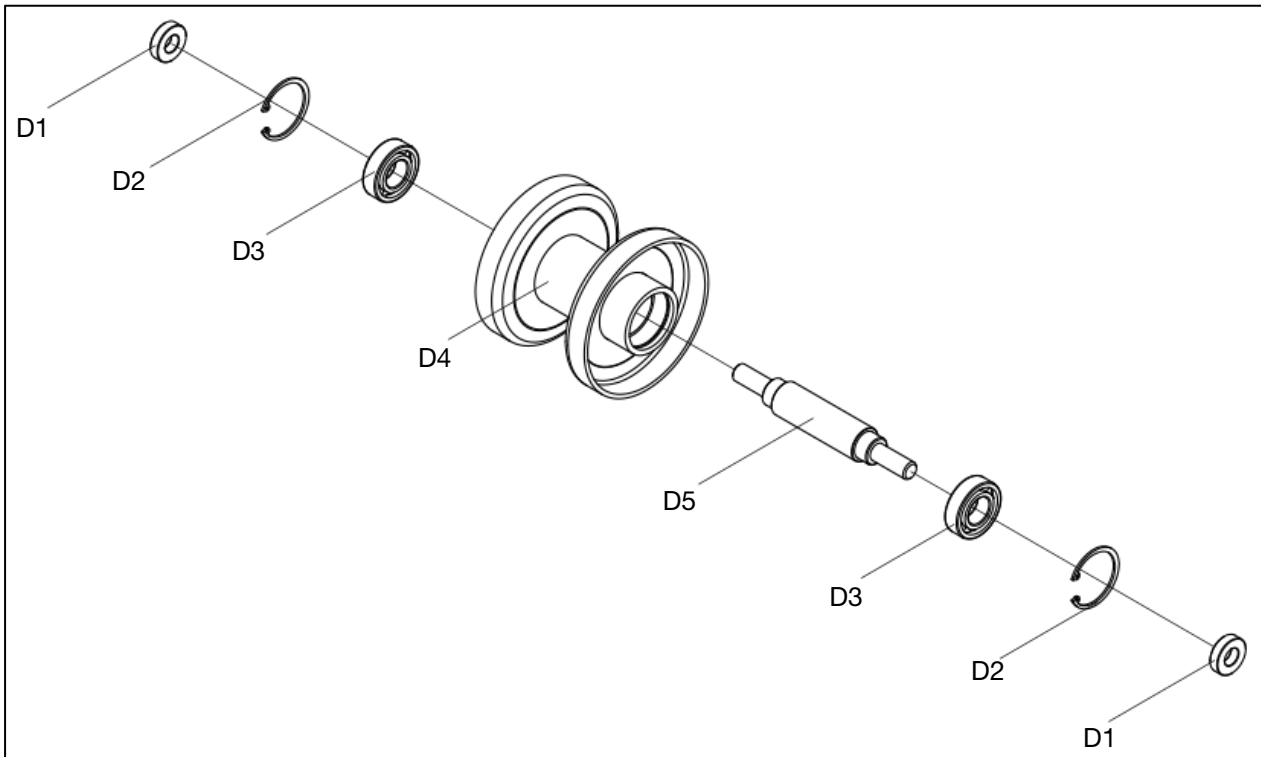

3.4 Walking System

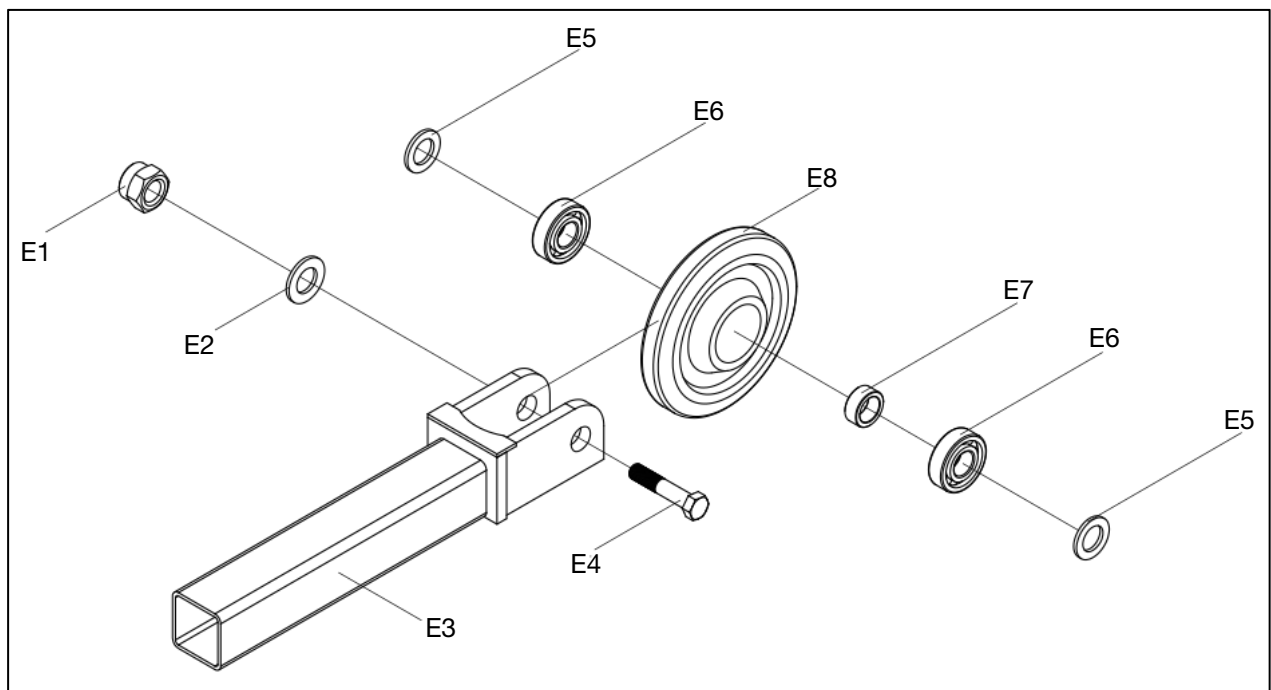

REF NO.	DESCRIPTION	QTY	REF NO.	DESCRIPTION	QTY
E1	Hexagon lock nut M20	2	E5	Small washer A-level Ø20	4
E2	Washer Ø20	2	E6	Bearing 6204-2RS	4
E3	Tension body welding assembly	2	E7	Tension pulley sleeve	2
E4	Bolt M20x100	2	E8	Tension pulley	2

Part 4: Power System

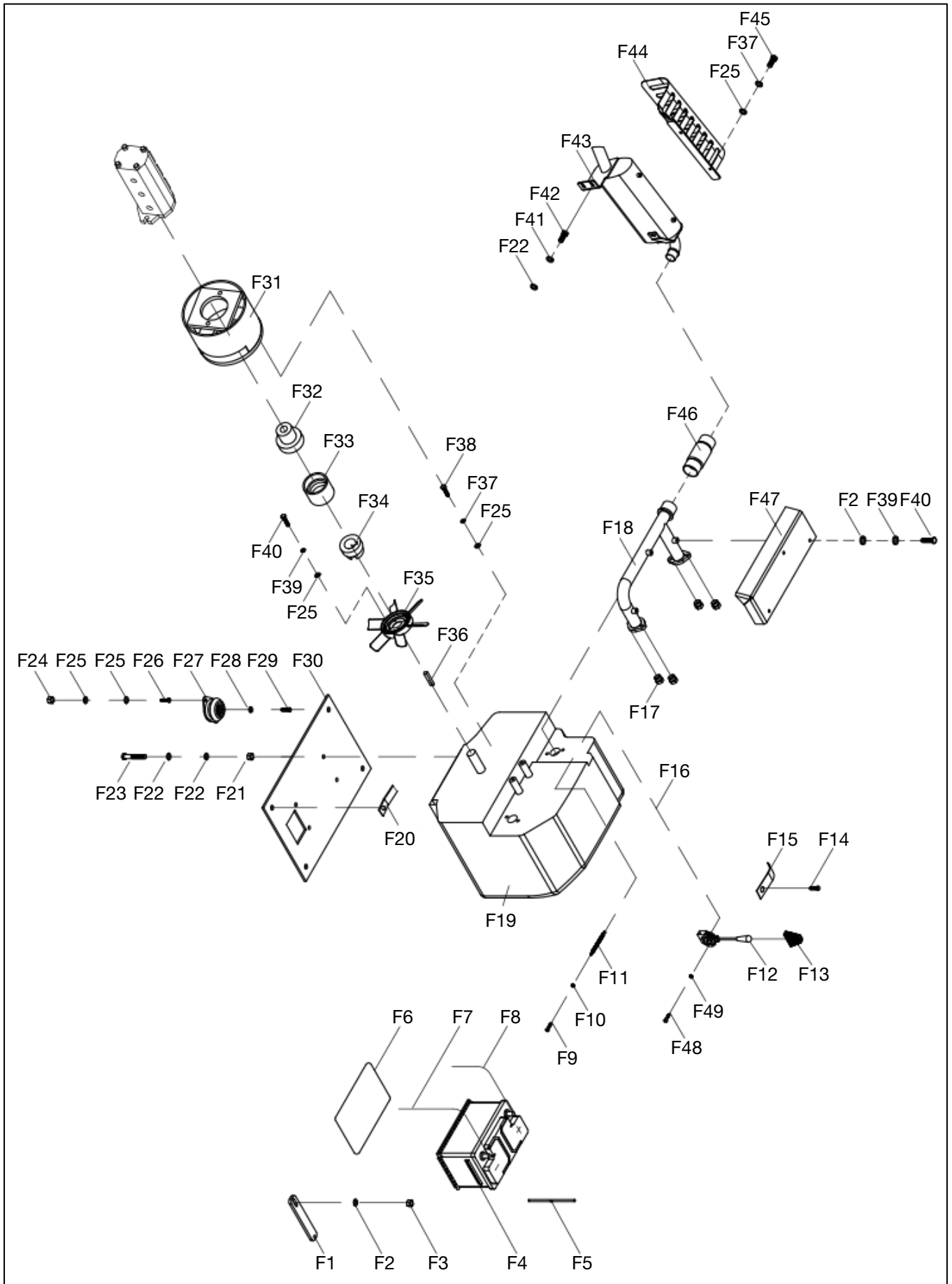

REF NO.	DESCRIPTION	QTY	REF NO.	DESCRIPTION	QTY
F1	Battery mounting plate	1	F26	Bolt M8x25	8
F2	Washer ϕ 6	5	F27	Shock absorber assembly	4
F3	Lock nut M8	1	F28	Washer ϕ 12	4
F4	Battery	1	F29	Bolt M12x30	4
F5	Washer ϕ 8	2	F30	Gasoline engine connecting plate	1
F6	Rubber sheet	1	F31	Engine and pump connecting parts welding assembly	1
F7	Ground wire	1	F32	Pump wheel	1
F8	Fire wire	1	F33	Connecting shaft nylon bush	1
F9	Bolt M6	1	F34	Connecting shaft sleeve	1
F10	Lock nut M6	1	F35	Fan assembly	1
F11	Return spring	1	F36	Key C6.3*6.6-30	1
F12	Hand throttle	1	F37	Washer ϕ 8	4
F13	Anti-dust rubber boot	1	F38	Bolt 5/16-24 UNF	4
F14	Screw M5x20	1	F39	Washer ϕ 6	3
F15	Pressure plate	1	F40	Bolt M6x16	3
F16	Throttle cable	1	F41	Washer ϕ 10	3
F17	Lock nut M8	4	F42	Bolt M10x20	3
F18	Exhaust pipe welding assembly	1	F43	Muffler welding assembly	1
F19	GX630 engine	1	F44	Guard welding assembly	1
F20	Earth wire	1	F45	Bolt M8x20	2
F21	Lock nut M10	4	F46	Bellows welding assembly	1
F22	Washer ϕ 10	7	F47	Exhaust pipe guard	1
F23	Bolt M10x45	4	F48	Screw M6x20	2
F24	Lock nut M8	8	F49	Lock nut M6	4
F25	Washer ϕ 8	12			

Part 5: Frame Assembly

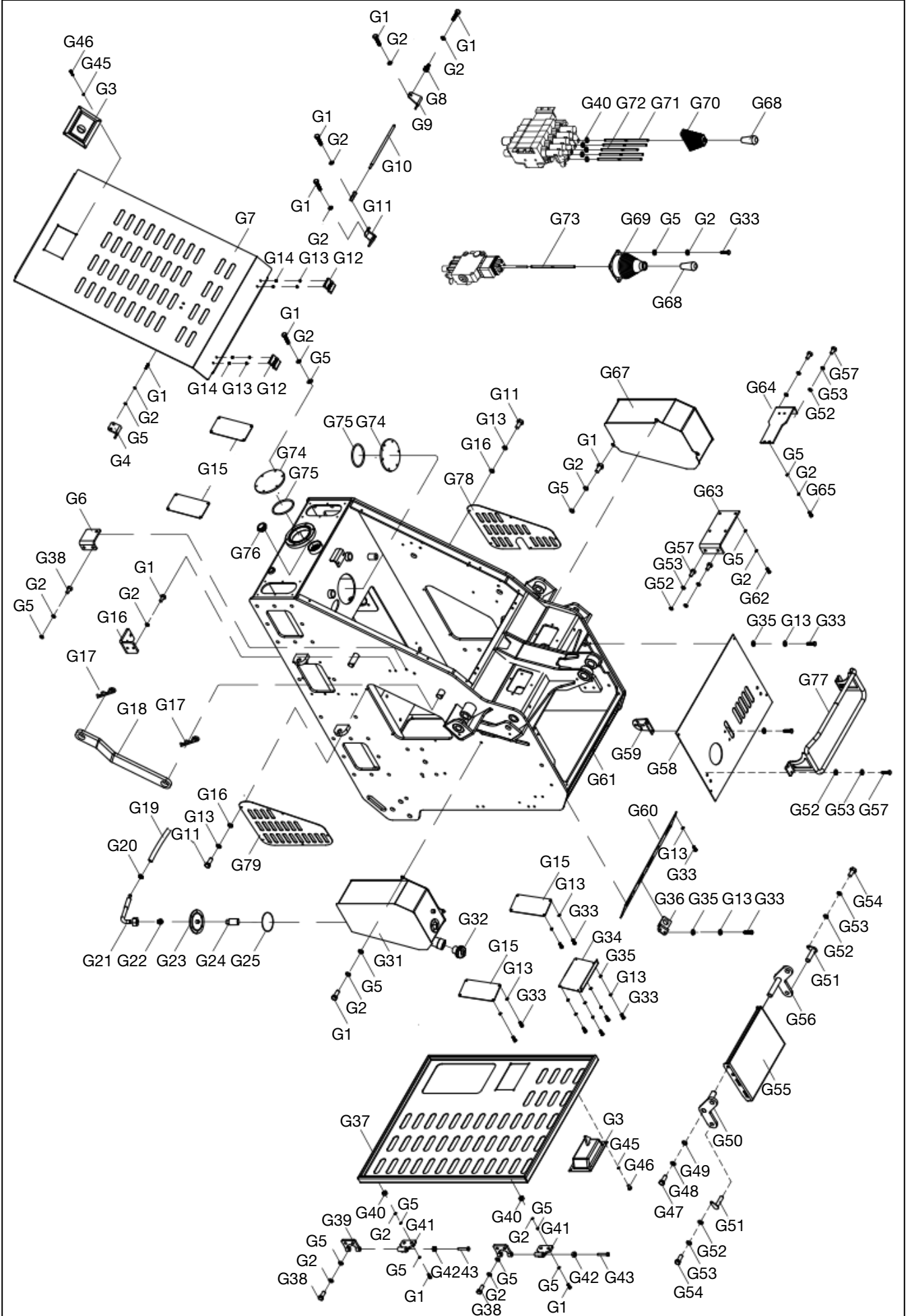

REF NO.	DESCRIPTION	QTY	REF NO.	DESCRIPTION	QTY
G1	Bolt M8x16	16	G41	Hing II	2
G2	Washer ϕ8	25	G42	Lock nut M6	2
G3	Cover plate lock	2	G43	Bolt M6x65	2
G4	Bracket	1	G44		
G5	Washer ϕ8	21	G45	Washer ϕ4	8
G6	Relief valve mounting plate	1	G46	Screw M4x8	8
G7	Cover plate	1	G47	Bolt M16x25	2
G8	Booth	1	G48	Washer ϕ16	6
G9	Dead plate	1	G49	Washer ϕ16	6
G10	Studdle	1	G50	Left fixed pin	1
G11	Bearing fixed bracket	1	G51	Foot pedal dowel pin welds	2
G12	Hinge	2	G52	Washer ϕ10	16
G13	Washer ϕ6	22	G53	Washer ϕ10	10
G14	Nut M6	4	G54	Bolt M10x25	2
G15	Cover plate I	4	G55	Foot pedal	1
G16	Return oil filter fixed plate	1	G56	Right foot pedal fixed pin	1
G17	Crank pin	2	G57	Bolt M10x20	8
G18	Working arm bumper	1	G58	Upper cover plate	1
G19	Fuel hose	1	G59	Hand throttle mounting seat	1
G20	Hose clamp	2	G60	Instrument panel	1
G21	Fuel oil transition connector	1	G61	Frame welding assembly	1
G22	Crossover sub	1	G62	Bolt M8x20	7
G23	Flange welding assembly	2	G63	5-spool valve supporting plate	1
G24	Fuel filter 25-100	2	G64	2-spool valve supporting plate	1
G25	O-ring 65x3.1	2	G65	Bolt M8x60	3
G26			G66		
G27			G67	Right toolbox welding assembly	1
G28			G68	Handle wrap	6
G29			G69	Double valve handle boot	1
G30			G70	Anti-dust boot	5
G31	Left oil tank welding assembly	1	G71	5-spool valve handle lever	4
G32	Oil tank cap	1	G72	5-spool valve handle lever	1
G33	Bolt M6x16	16	G73	Universal valve handle	1
G34	Battery cover plate	1	G74	Oil clean-out opening pressure plate	2
G35	Washer ϕ6	6	G75	O-ring 94.6x5.3	2
G36	Pressure meter fixing bracket	1	G76	Oil scale	1
G37	Rear guard plate welds	1	G77	Handle bracket	1
G38	Bolt M8x20	4	G78	Right fender	1
G39	Hing I	2	G79	Left fender	1
G40	Nut M8	9			

Part 6: Mechanical Control

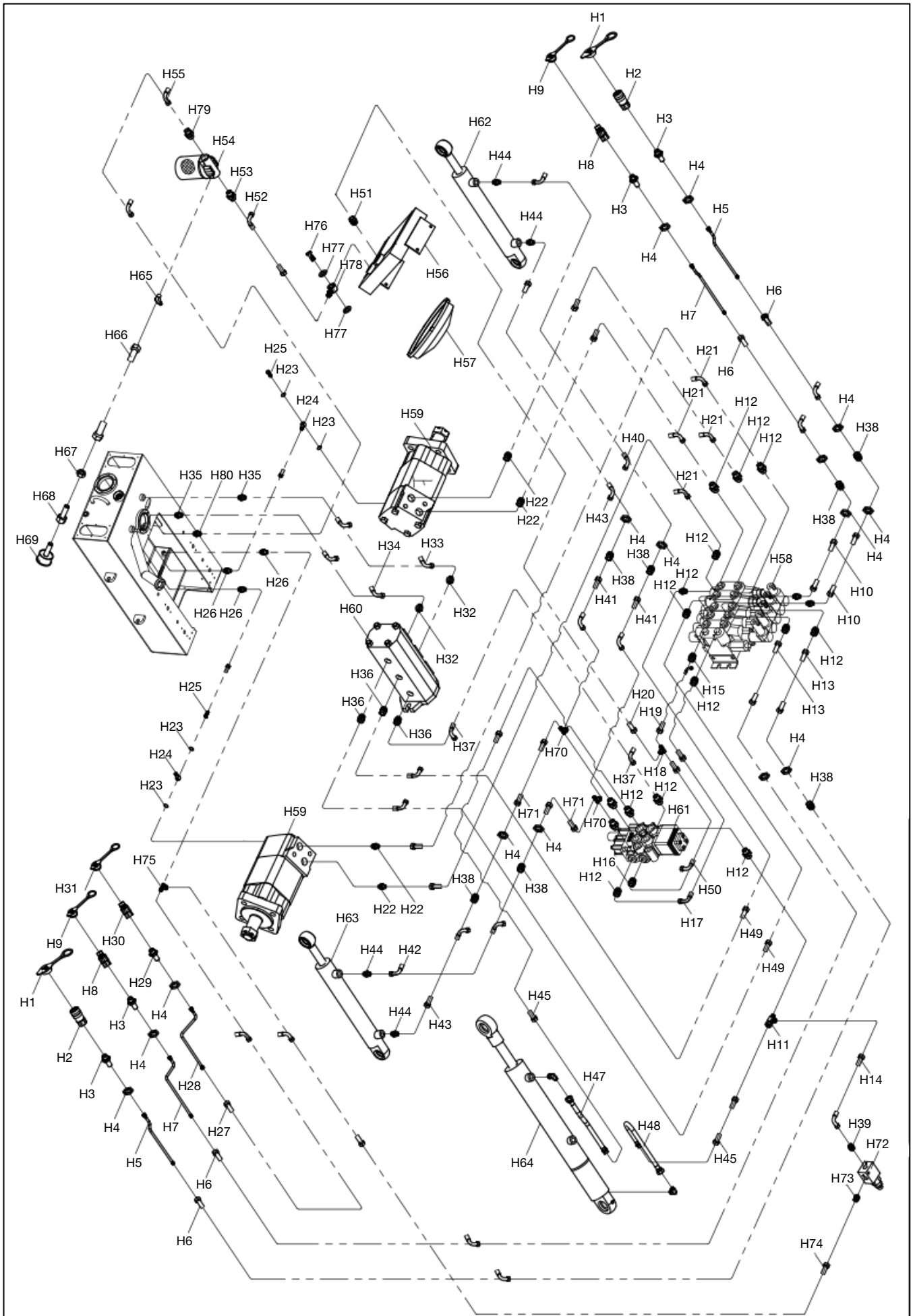

REF NO.	DESCRIPTION	QTY	REF NO.	DESCRIPTION	QTY
H1	G1/2 quick-change coupler (female) cap	2	H41	2-spool valve right oil hose	2
H2	G1/2 quick-change coupler (male)	2	H42	Lift cylinder rod end hose	1
H3	G1/2 quick-change coupler body	4	H43	Lift cylinder rear end hose	2
H4	Bolt M18X1.5	21	H44	Double union tee body	4
H5	Left arm steel pipe I	2	H45	Tilt cylinder rod end hose	2
H6	Attachment hose	4	H46		
H7	Left arm steel pipe II	2	H47	Bucket steel pipe II	1
H8	G1/2 quick-change coupler (male)	2	H48	Bucket steel pipe I	1
H9	G1/2 quick-change coupler (male) cap	2	H49	Motor-valve oil hose	2
H10	Right attachment steel pipe	2	H50	2-spool valve oil return hose	1
H11	Tee joint	2	H51	Radiator joint body	2
H12	Balance valve connector	18	H52	Radiator oil outlet hose	1
H13	Left attachment steel pipe	2	H53	Filter connector	2
H14	Relief valve inlet line	1	H54	Filter	1
H15	Oil return connector	1	H55	Filter oil outlet hose	1
H16	Balance valve connector	1	H56	Oil radiator assembly	1
H17	5-spool valve oil inlet hose	1	H57	Radiator fan	1
H18	Union tee	1	H58	Valve body assembly (5-spool)	1
H19	5-spool valve oil return hose	1	H59	Motor assembly	2
H20	Radiator oil return hose	1	H60	Gear pump	1
H21	Motor-valve oil pipe	4	H61	2-spool valve	1
H22	Straight thread connector	4	H62	Right lift cylinder	1
H23	Combined washer ϕ 14	4	H63	Left lift cylinder	1
H24	Motor oil return hose	2	H64	Bucket cylinder	1
H25	Hollow bolt G1/4	2	H65	Vacuum meter right angle connector	1
H26	Return oil connector	3	H66	Vacuum meter hose	1
H27	Left arm steel pipe III	2	H67	Nut M14x1.5	1
H28	Attachment oil return hose	1	H68	Vacuum meter connector	1
H29	G3/8 coupler body	1	H69	Sensor	1
H30	G3/8 quick-change coupler (male)	1	H70	Tee joint	2
H31	G3/8 quick-change coupler (male) cap	1	H71	2-spool valve left oil hose	2
H32	Gear pump oil inlet hose	2	H72	Relief valve	1
H33	Gear pump oil inlet hose I	1	H73	Relief valve connector I	1
H34	Gear pump II	1	H74	Relief valve return hose	2
H35	Radiator connector	3	H75	Tee joint	1
H36	Gear pump oil outlet connector	3	H76	Hollow bolt	1
H37	2-spool oil inlet hose	1	H77	E-ring 29.7x35.7x1.5	2
H38	Transition joints	8	H78	Radiator oil outlet connector	1
H39	Relief valve connector II	1	H79	Filter connector III	1
H40	Lift cylinder right oil hose	1	H80	Tank return oil connector III	1

Part 7: Wiring Schematic

