

1220 Metal Livestock Shed

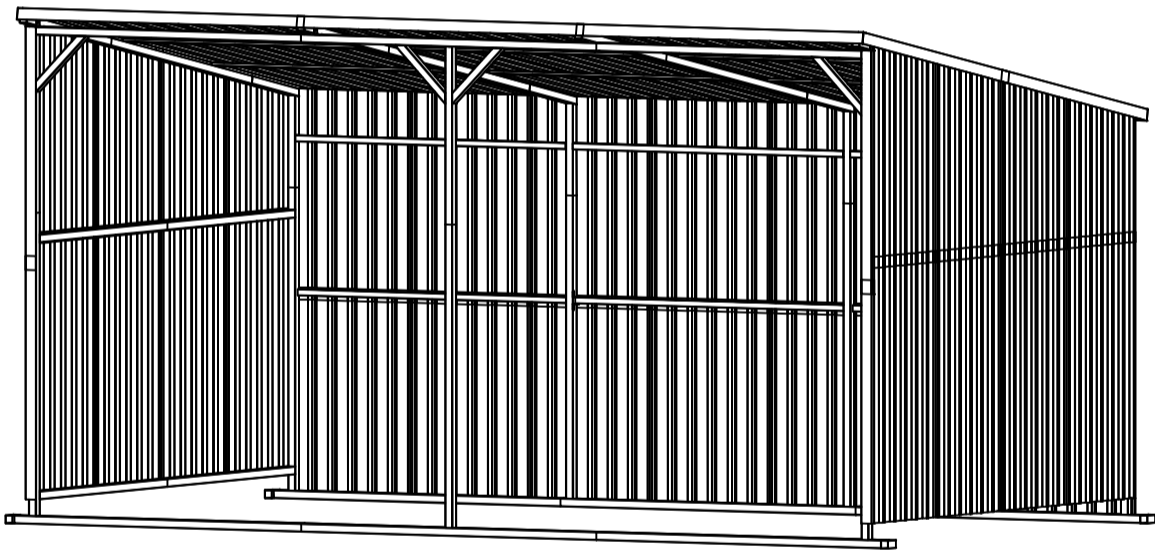

⚠ WARNING



- Please read and understand the product manual completely before assembly
- Check against the parts list to make sure all parts are received
- Wear proper safety goggles or other protective gears while in assembly
- Do not return the product to dealer. They are not equipped to handle your requests.

Missing parts or have questions on assembly?
Please call: 1-877-761-2819 or email: cs@tmgindustrial.com

BEFORE YOU START:

- Before beginning construction, check local building codes regarding footings, location and other requirements.
- Study and understand this owner's manual. Important information and helpful tips will make your construction easier and more enjoyable.
- Instructions are supplied in this manual and contain all appropriate information for your building model. Review all instructions before you begin, and during assembly, follow the step sequence carefully for successful results. Identify all parts and check quantities against parts list.
- Be sure the day you select to install your building is dry and calm. Do not attempt to assemble your building on a windy day. Be careful on wet or muddy ground.
- Whenever possible, two or more people should work together to assemble your building. One person can position parts or panels while the other is able to handle the fasteners and the tools.

SAFETY FIRST !









Safety precautions are important to follow throughout the construction of your building.

- Care must be taken when handling various pieces of your building since some contain sharp edges. Please wear work gloves, eye protection and long sleeves when assembling or performing any maintenance on your building.
- Keep children and pets away from worksite to avoid distractions and any accidents which may occur.
- Never concentrate your total weight on the roof of the building. When using a step ladder make sure that it is fully open and on even ground before climbing on it.
- Practice caution with the tools being used in the assembly of this building. Be familiar with the operation of all power tools.
- Do not attempt to assemble the building if parts are missing because any building left partially assembled may be seriously damaged by light winds.
- Do not attempt to assemble the building on a windy day, because the large panels acting as a "sail" can be whipped about by the wind; making construction difficult and unsafe.





WARRANTY REQUIREMENTS:

- Wash all surfaces annually using a hose and soft nylon brush.
- Within 2 km of coast – wash every 3 months as above. After a storm, wash the cladding and the gutters as soon as possible to remove any highly corrosive salt deposits.
- Volcanic Ash Fallout – wash as soon as possible, removing fall out from roof and gutters.
- Do not allow manures, chemicals or other corrosive materials to have direct contact with cladding.





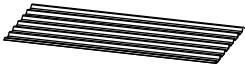
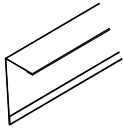
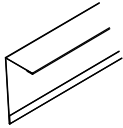
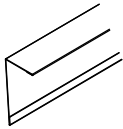
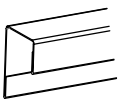
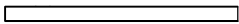



PARTS LIST

Item no.	Reference Image	Specification	Qty.
P1		1300*885mm	14
P3		1640*885mm	8
P4A		951*885mm	1
P5A		1101*885mm	1
P6A		1251*885mm	1
P7A		1400*885mm	1
P4B		951*885mm	1
P5B		1101*885mm	1
P6B		1251*885mm	1

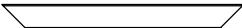



PARTS LIST

Item no.	Reference Image	Specification	Qty.
P7B		1400*885mm	1
P11		1390*885mm	7
P12		1260*885mm	14
ZL1		1500mm	4
ZL2		2008mm	6
ZL3		1900mm	4
ZU1		1966mm	3
A1		2007mm	4
A2		100mm	4

PARTS LIST

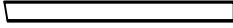
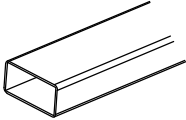
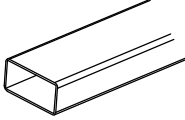
Item no.	Reference Image	Specification	Qty.
A3		2068mm	3
A5		1096mm	3
A6		500mm	4
A7		1641mm	8
A8		1867mm	7
A9		1100mm	4
A10		1838mm	4
A12		1907mm	2
A13		617mm	4



PARTS LIST

Item no.	Reference Image	Specification	Qty.
A14		566mm	4
B1		1893mm	6
B3		1944mm	9
K6		40*40*40	6
S1		M5*20	380
K9		300mm	8
M1		50*50	4

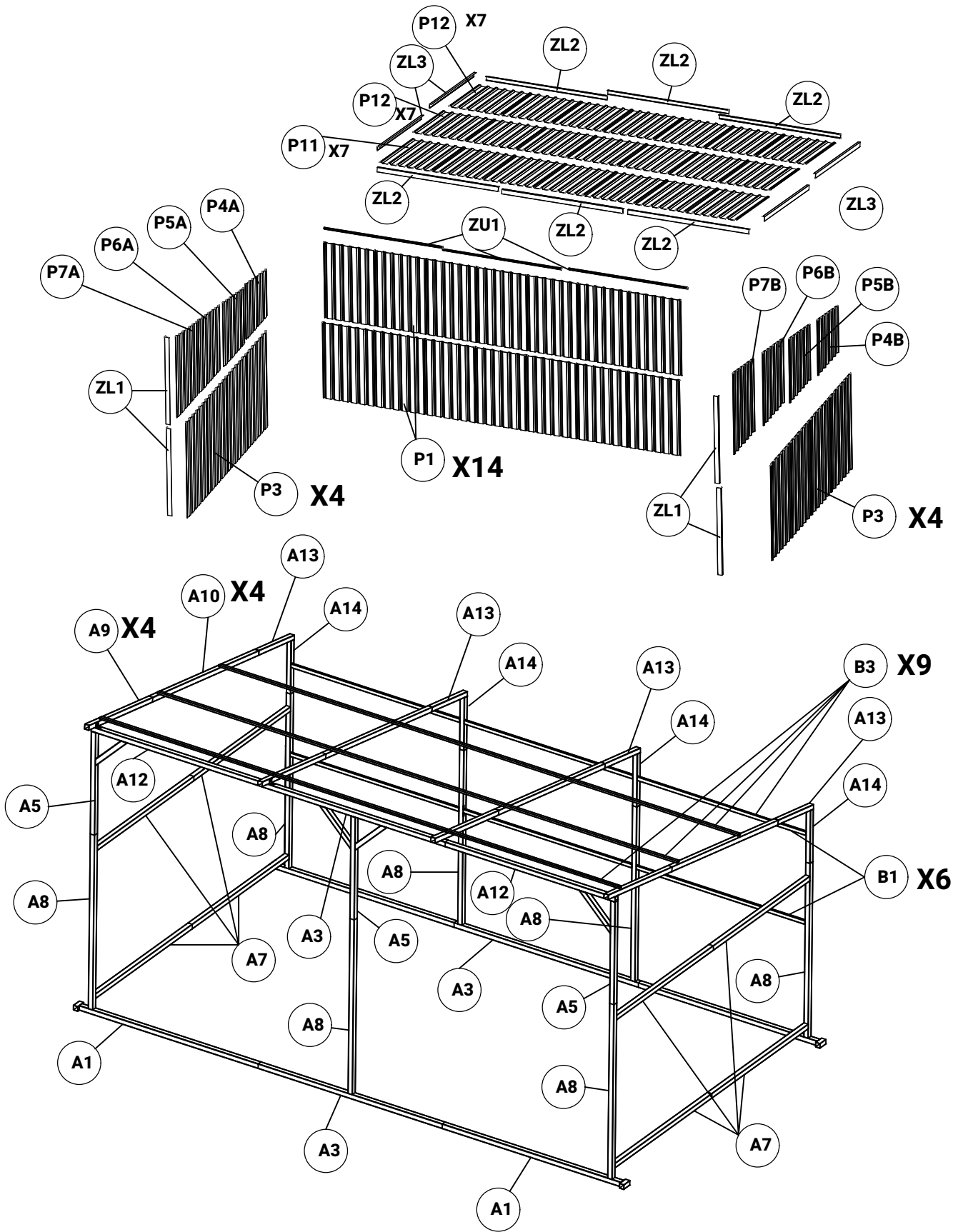
ASSEMBLY BY KEY NO.

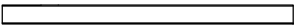
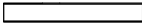

Step 1

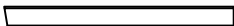
A8	A5	A7	A14
			
X4	X2	X8	X2

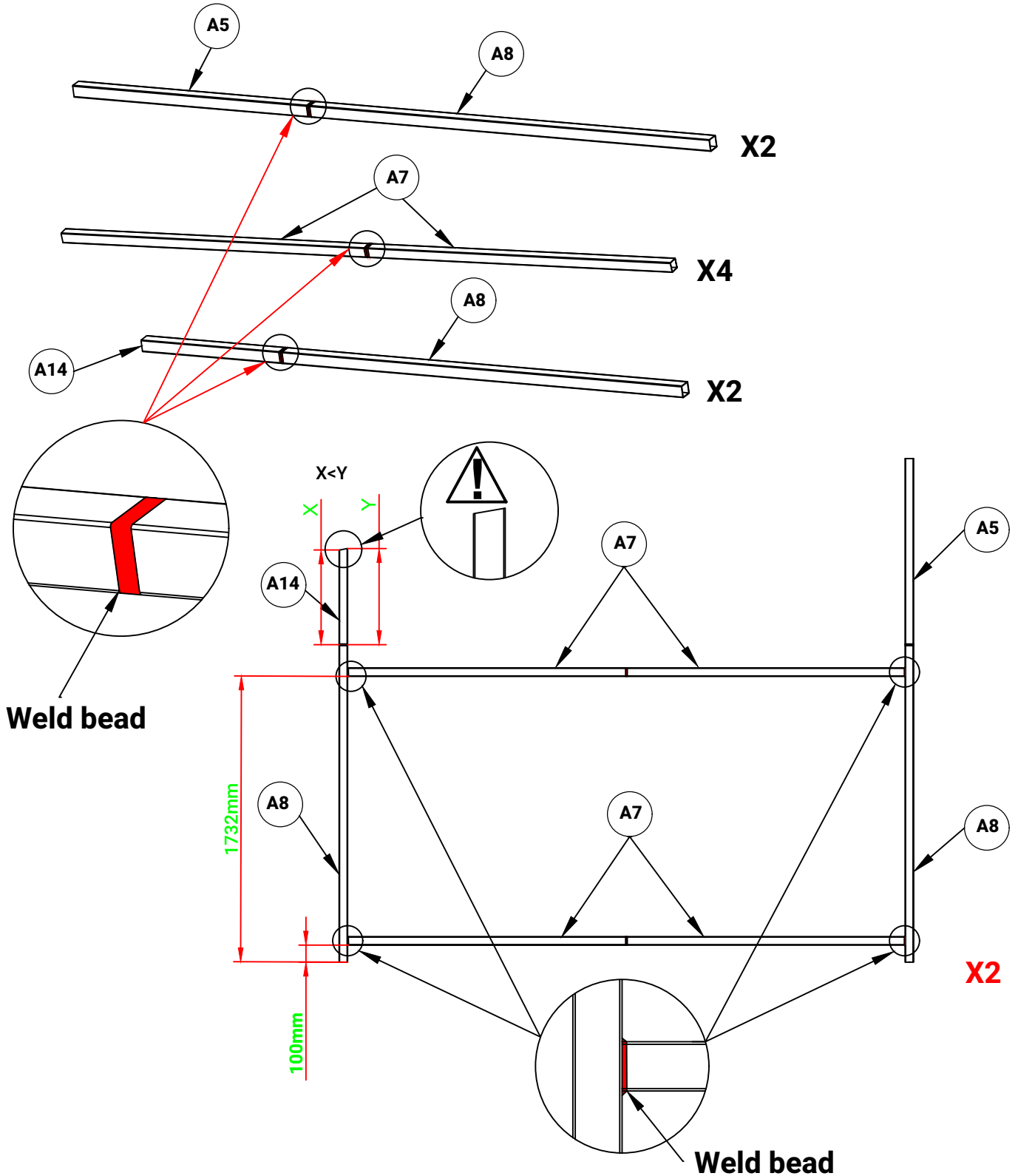

Step 2

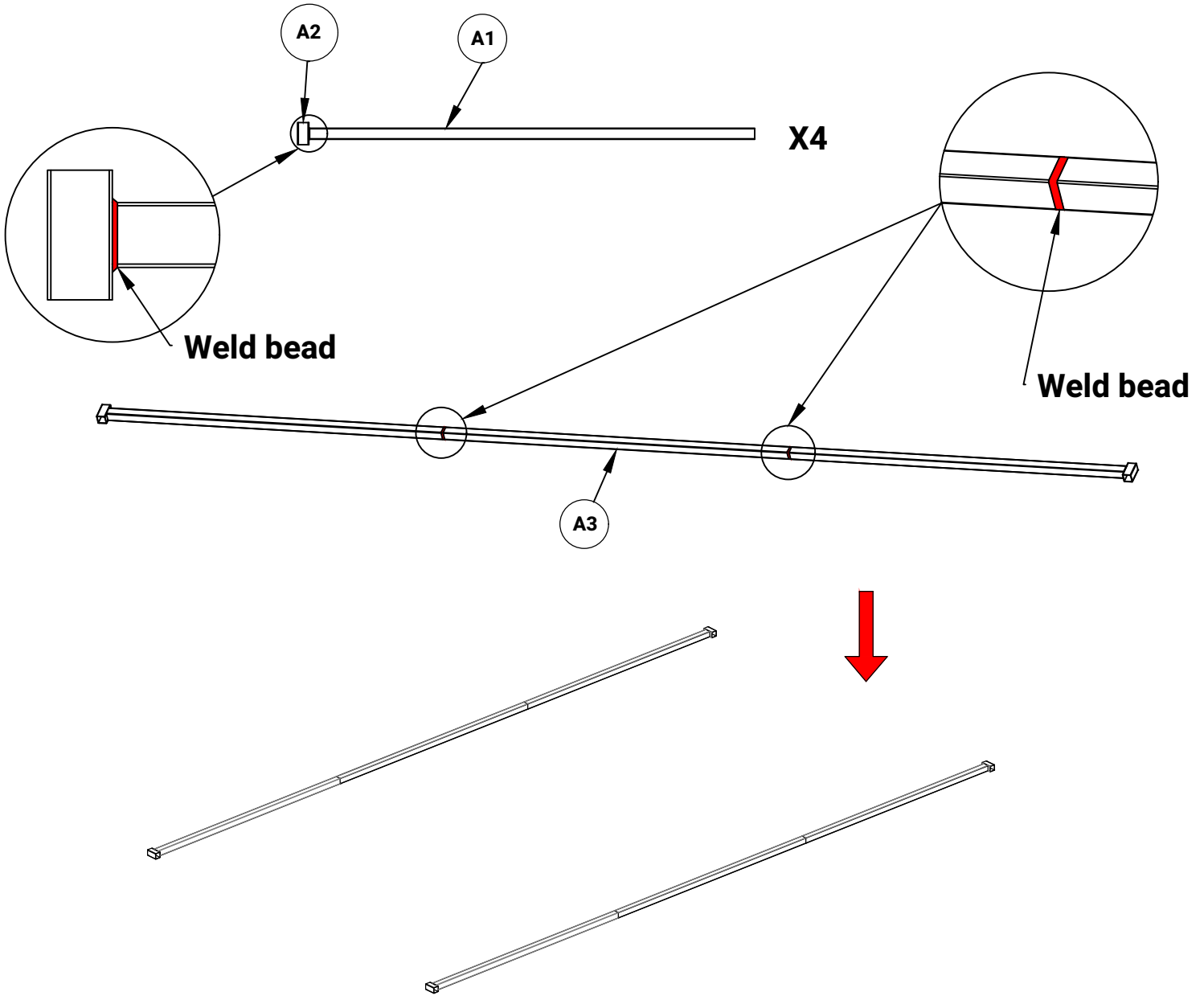
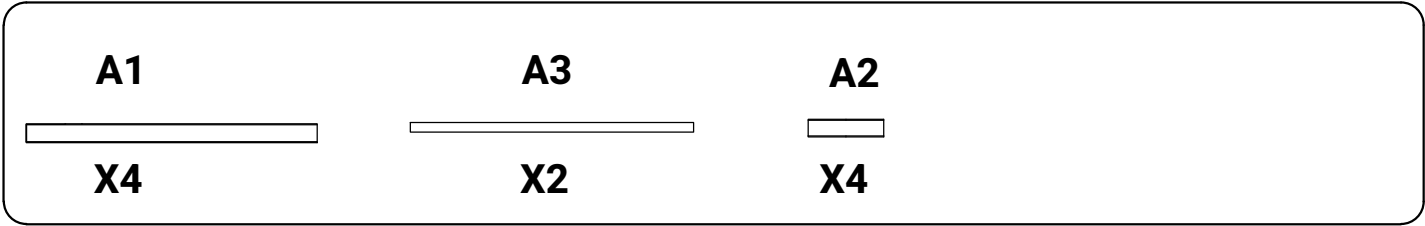

Step 3



X2

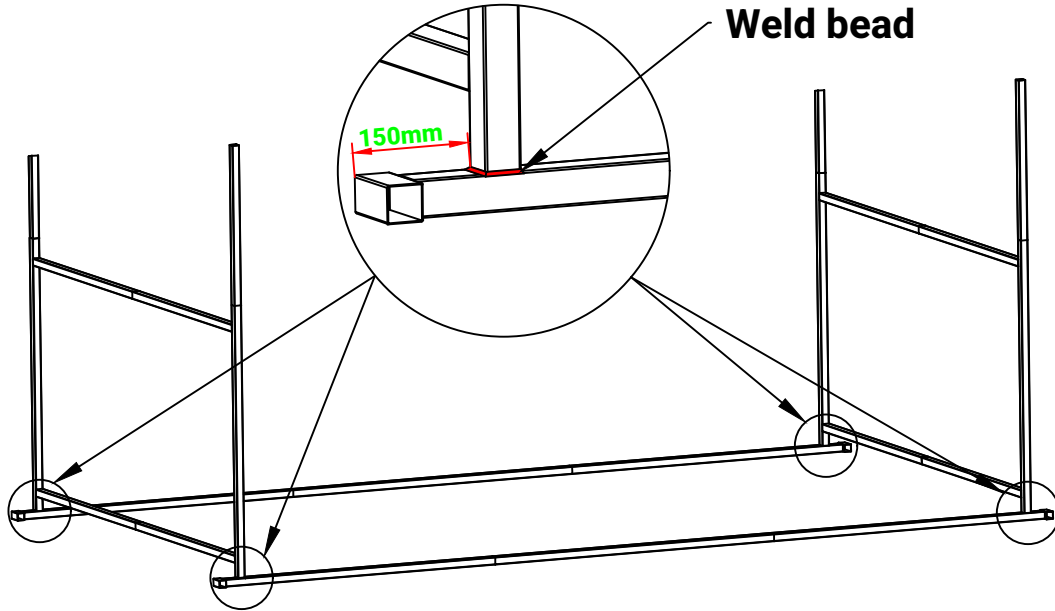

Step 4

A12

A3

A8

A5

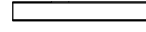
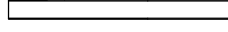
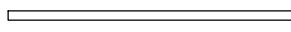
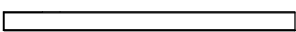

X2

X1

X1

X1

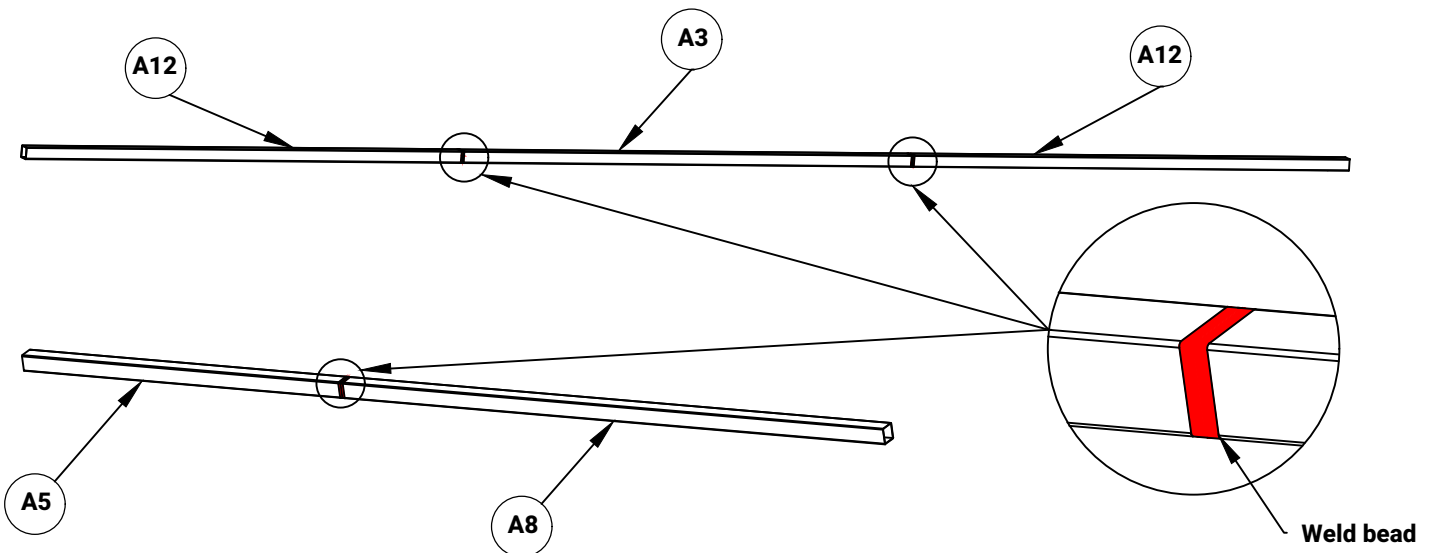

Step 5

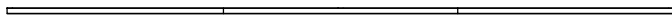

X1



X1

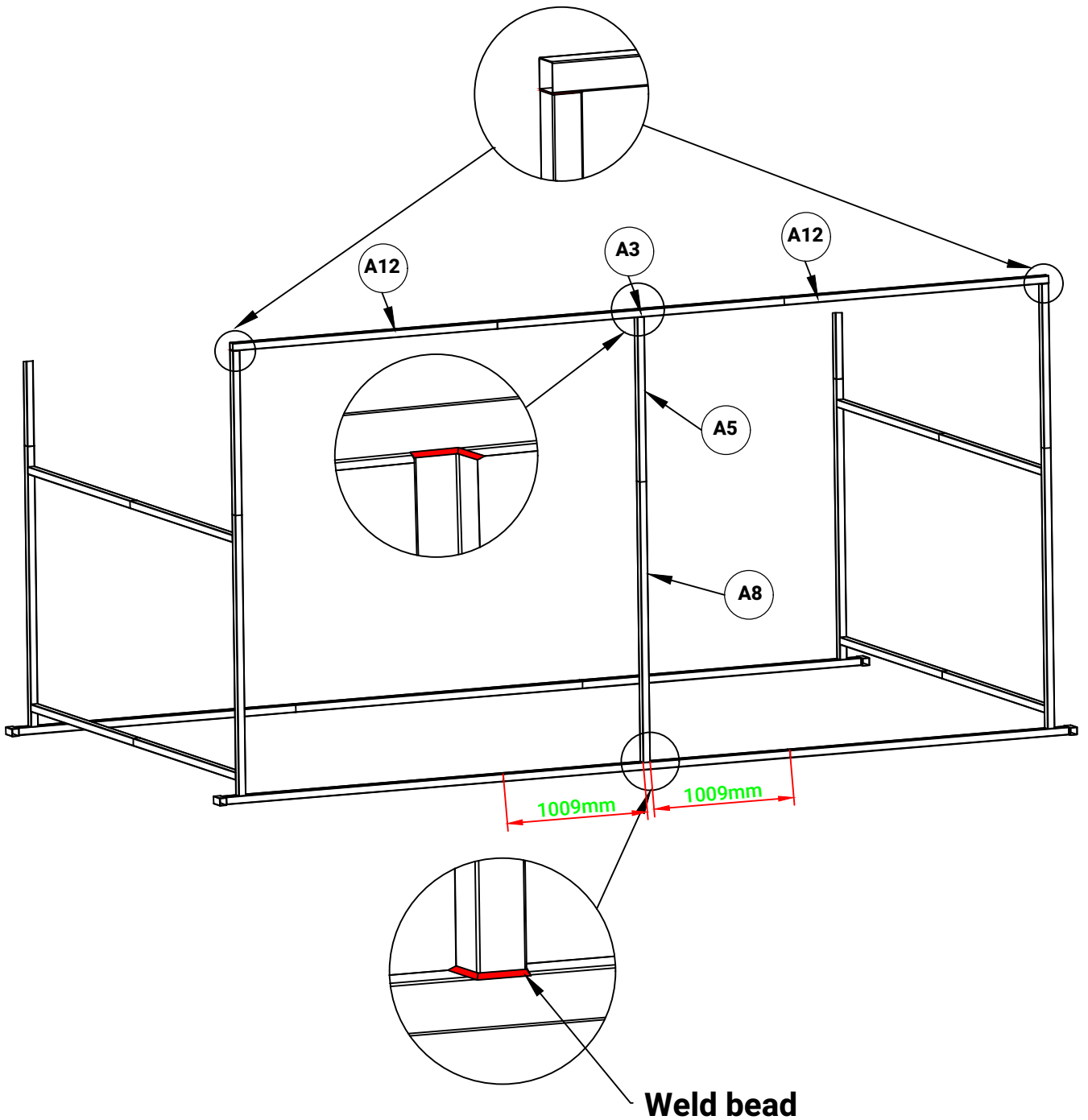

Step 6





A6

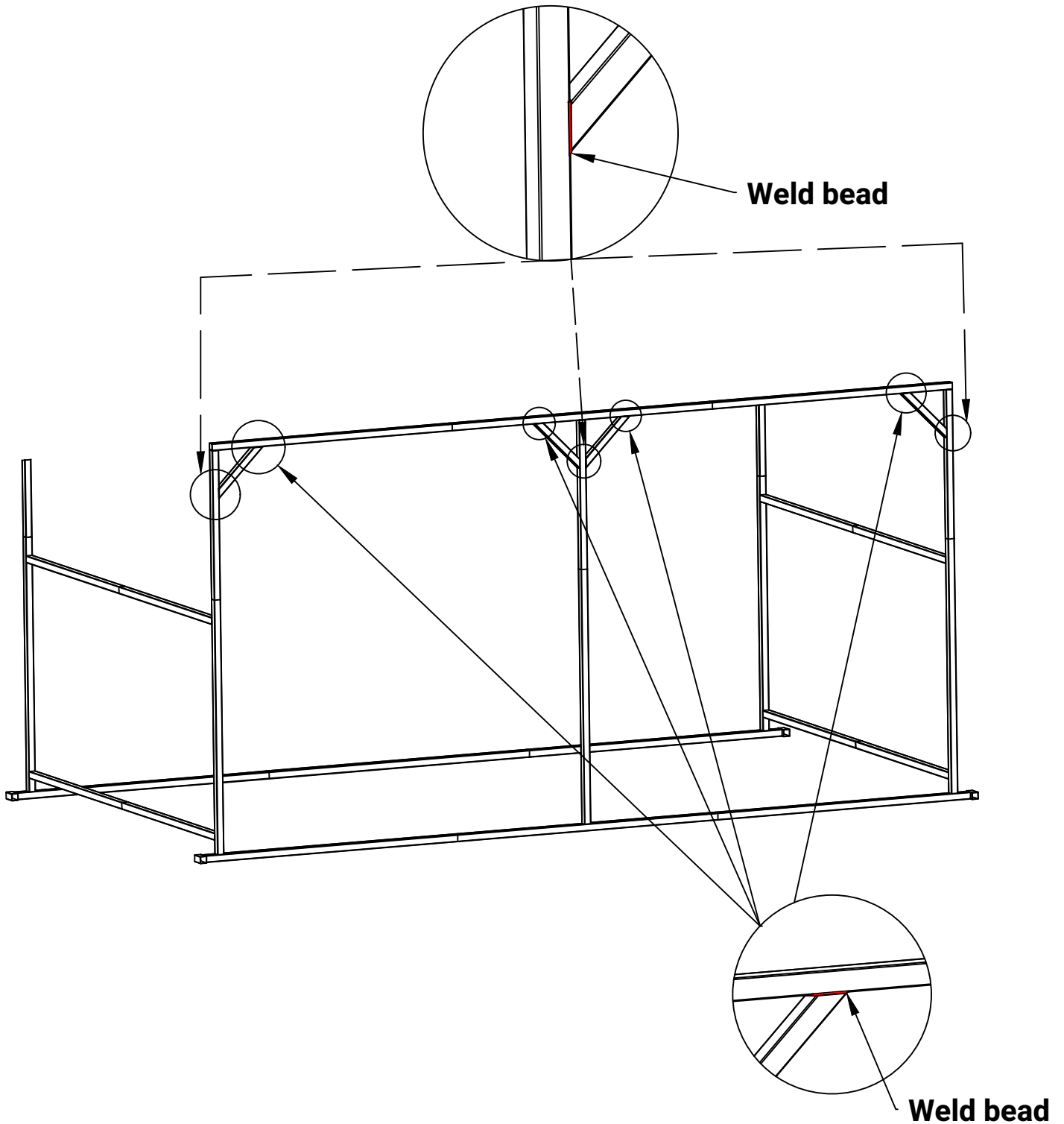

X4

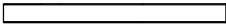
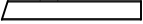



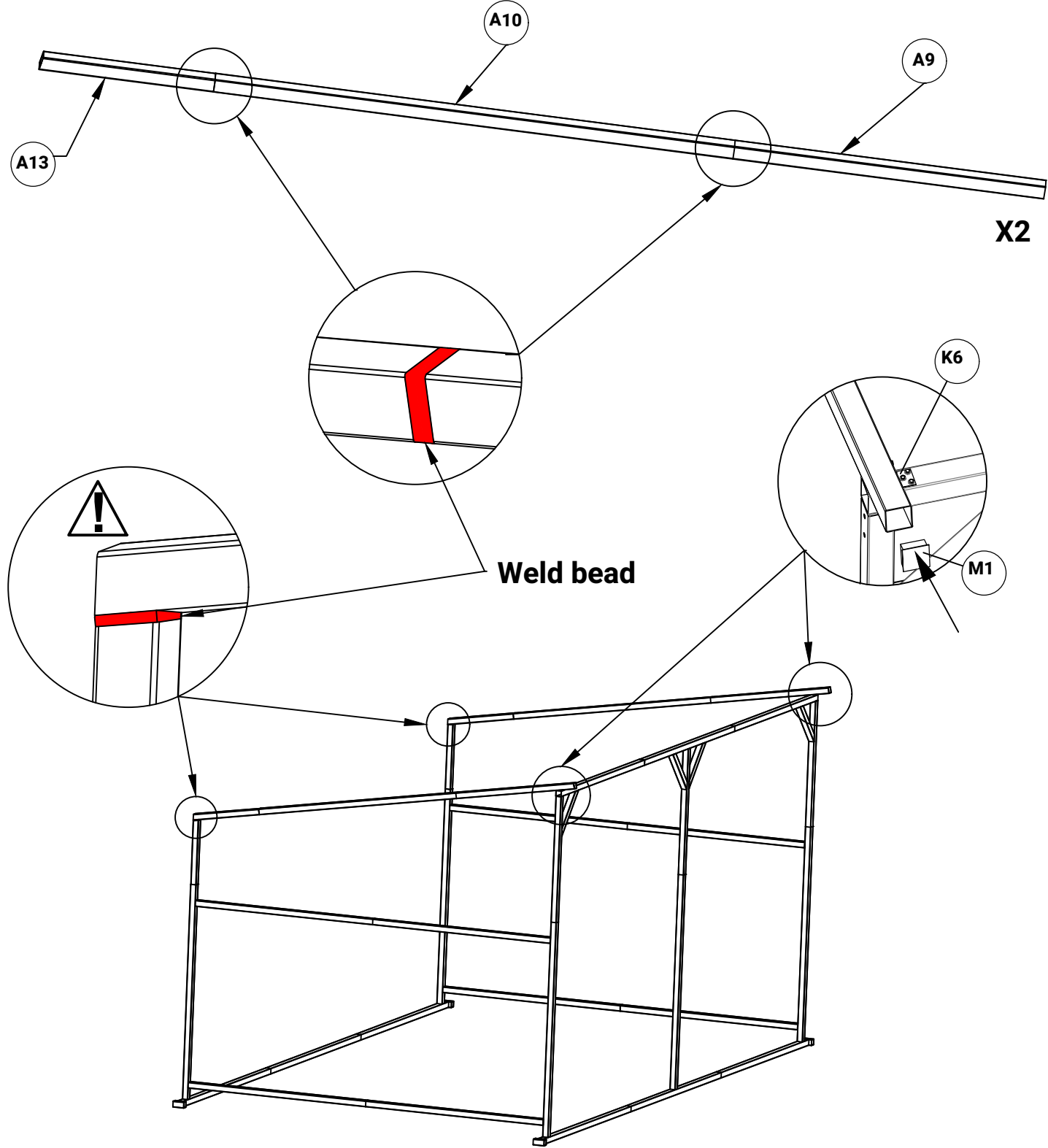

Step 7

A9	A10	A13	K6	S1	M1
					
X2	X2	X2	X2	X12	X2

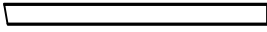

Step 8

A8	A9	A10	A13	A14
				
X2	X2	X2	X2	X2

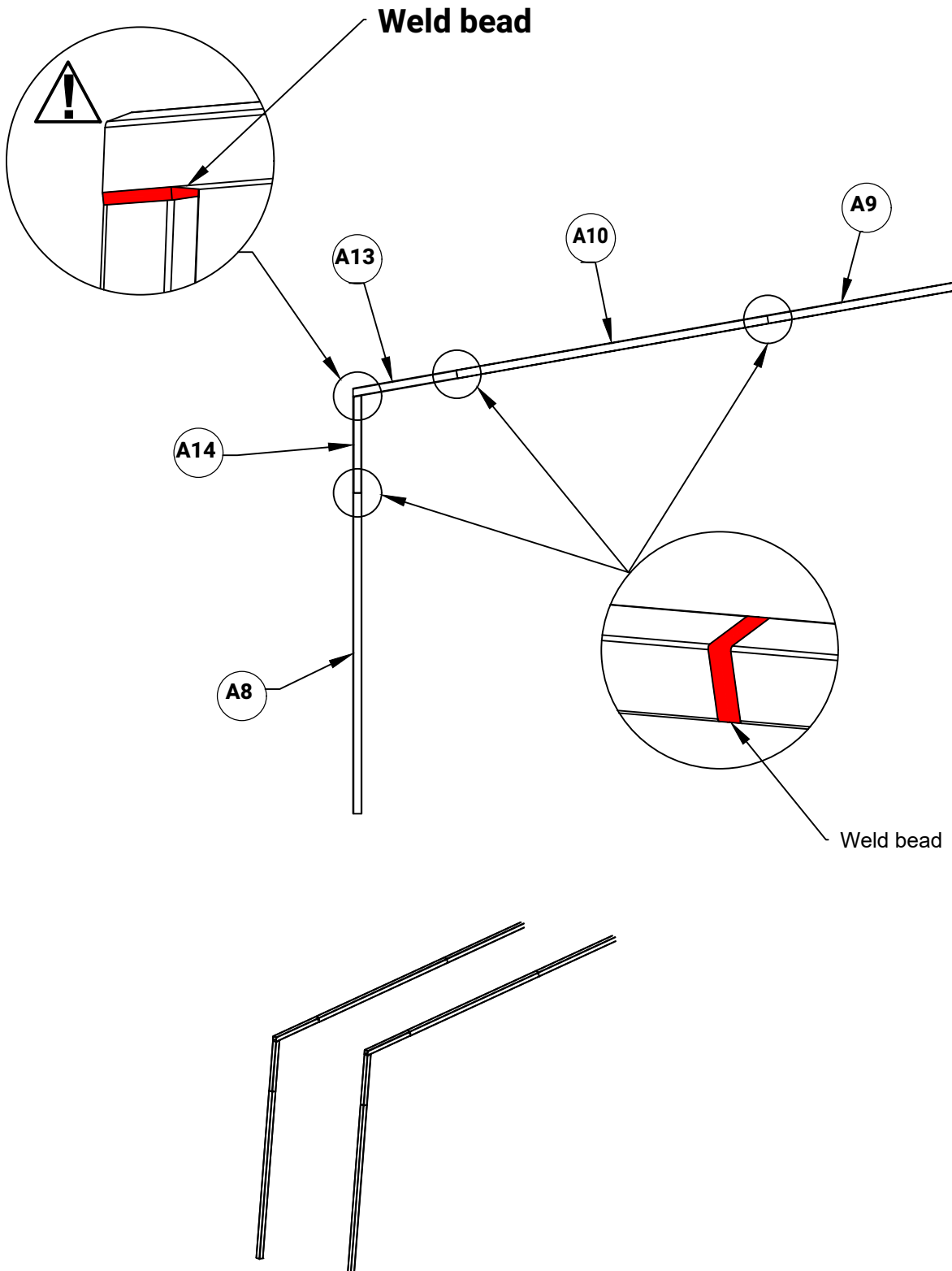

Step 9

X1 **B1**
X2

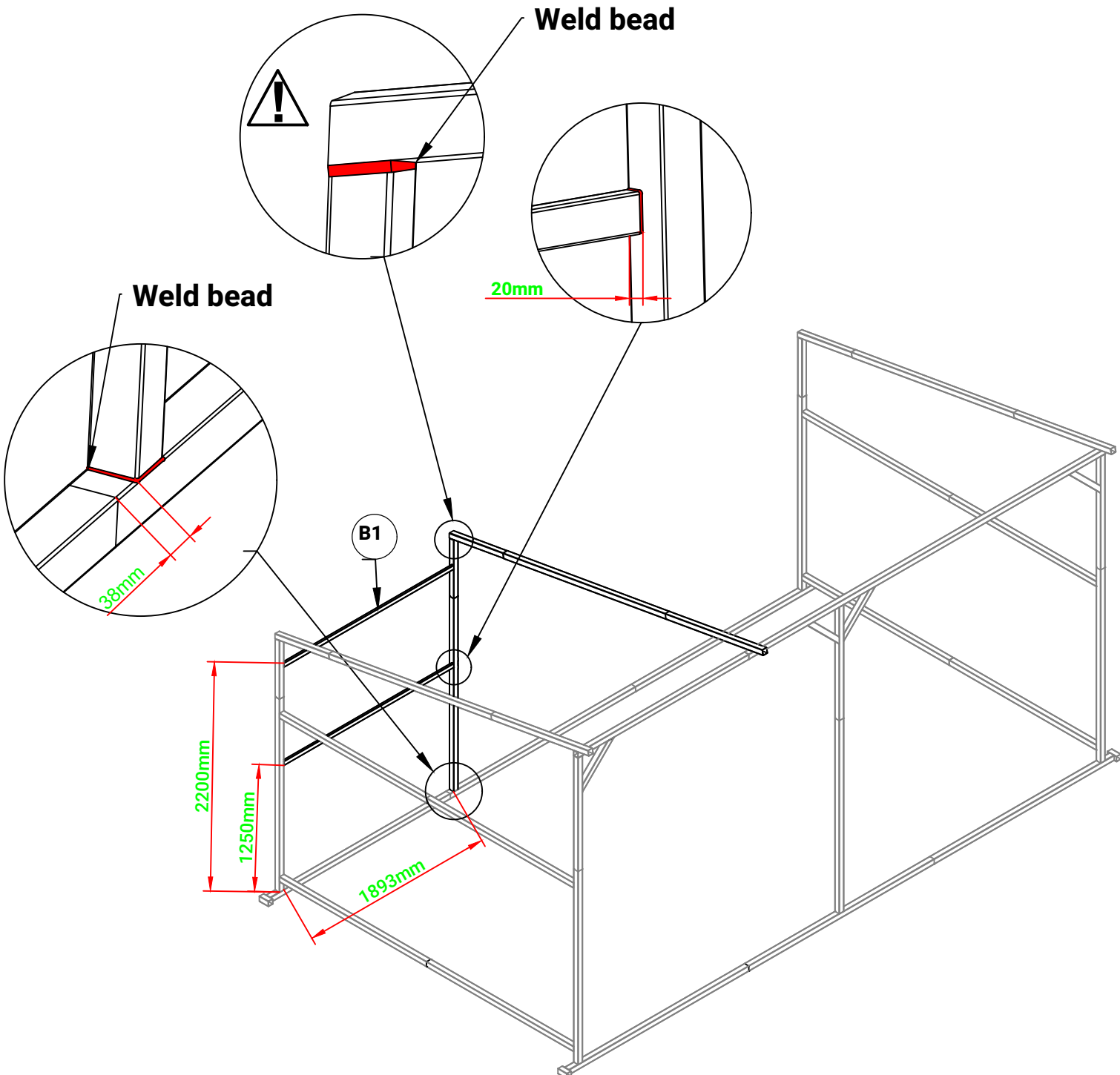
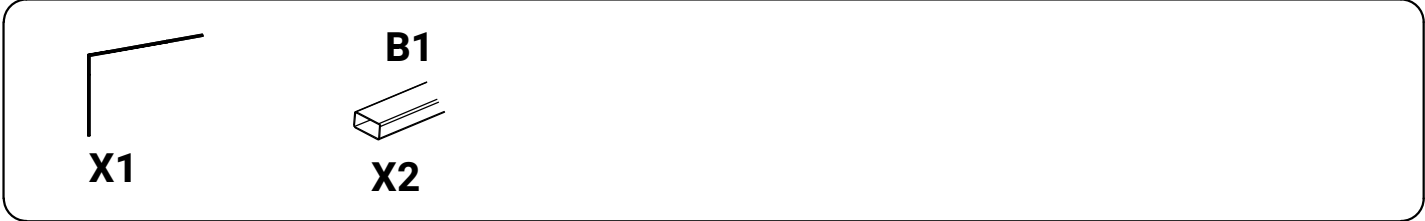

Step 10

X1 B1
X4

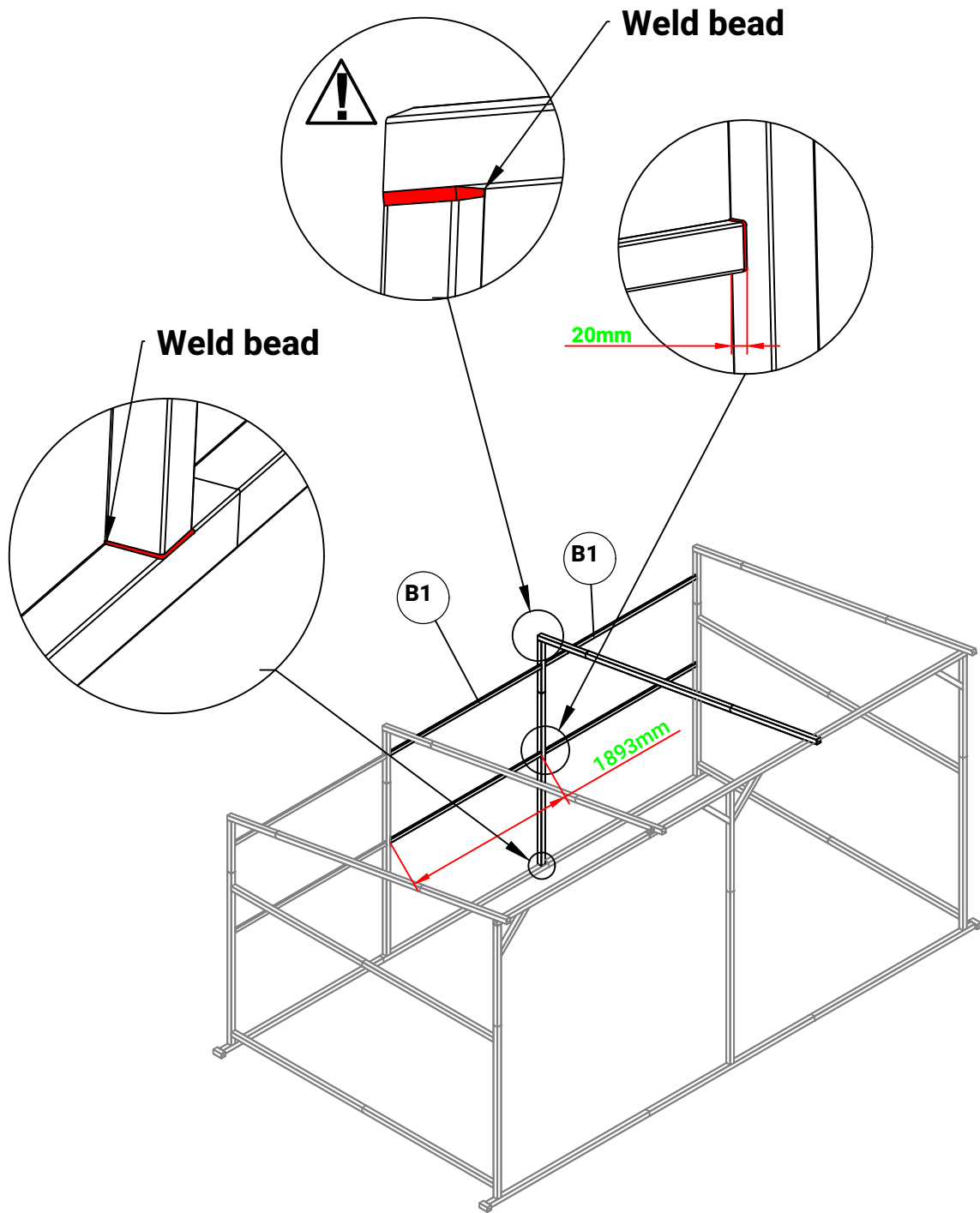

Step 11

M1

K6

S1



X2

X4

X24

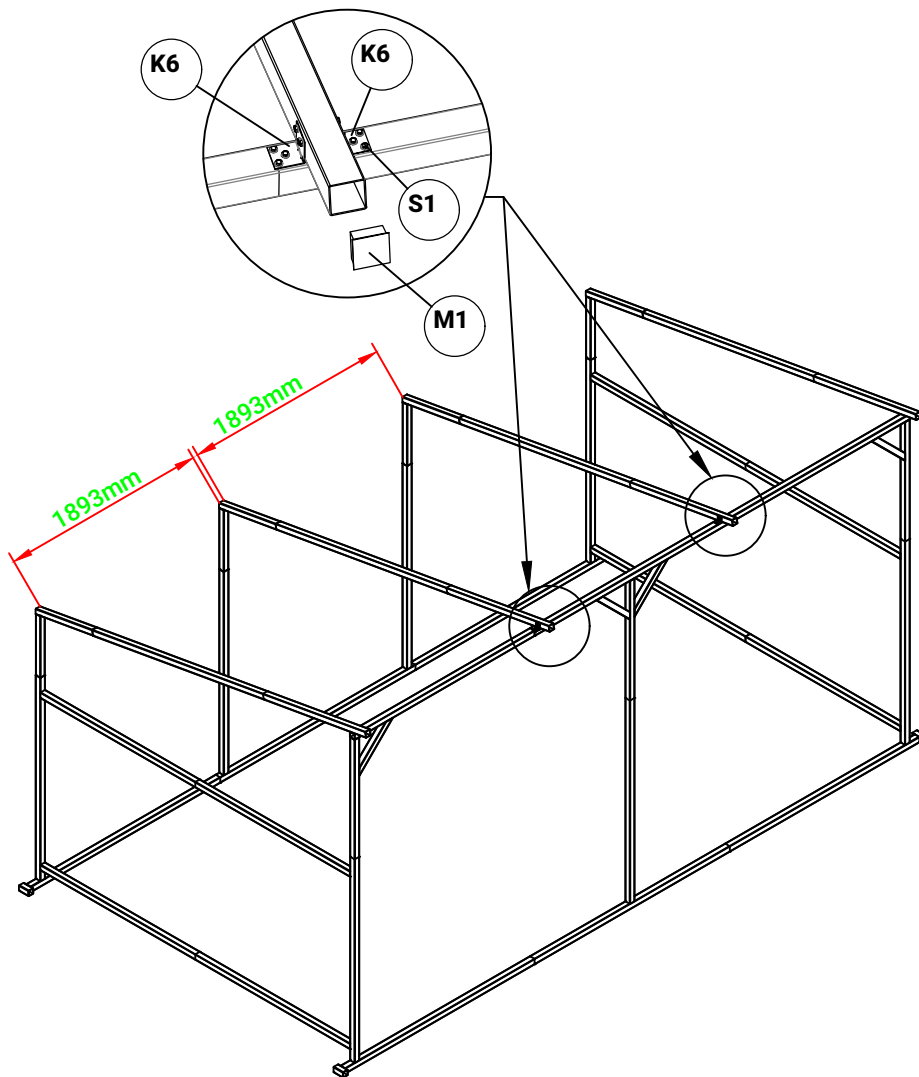

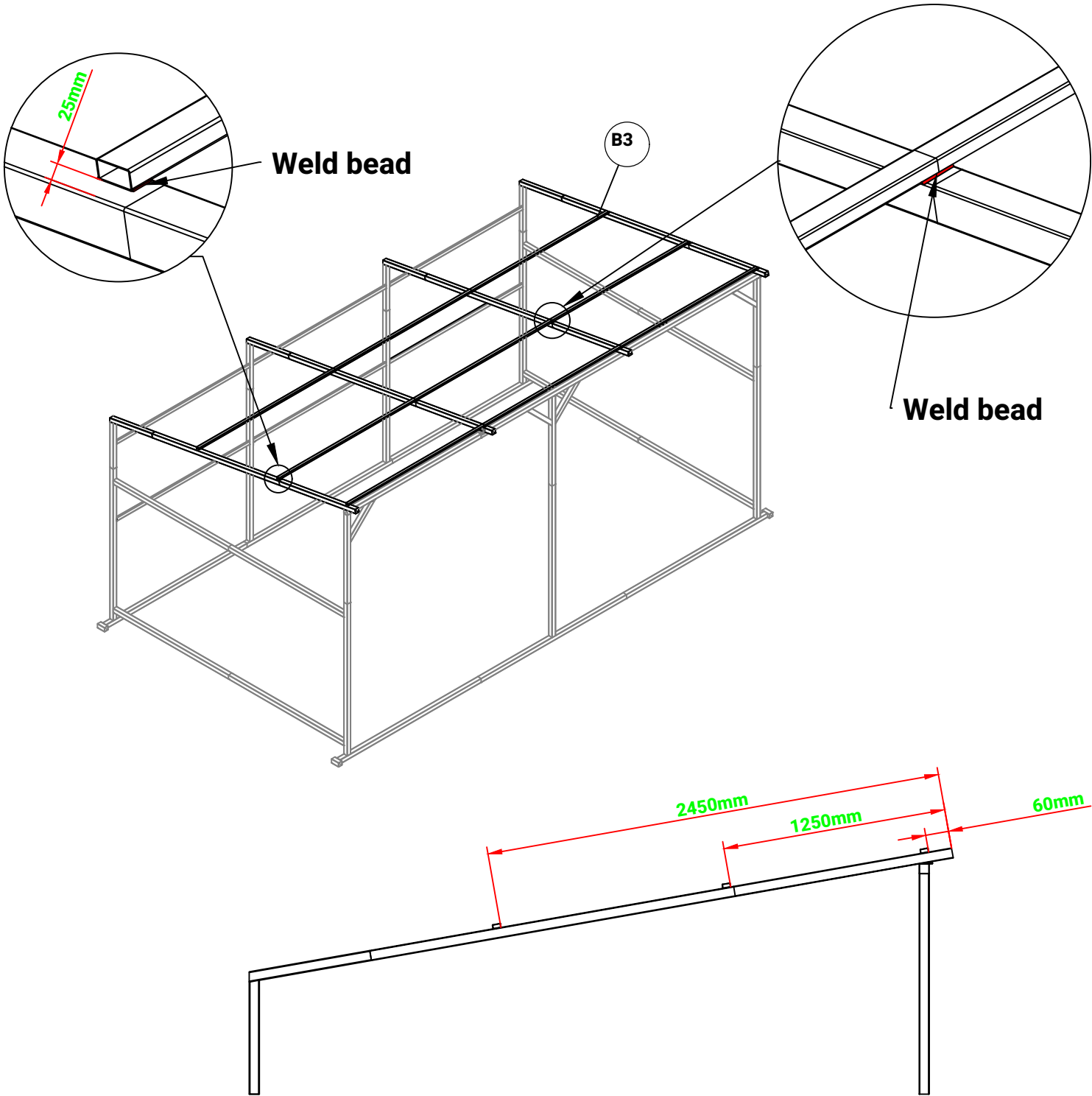

Step 12

B3

X9



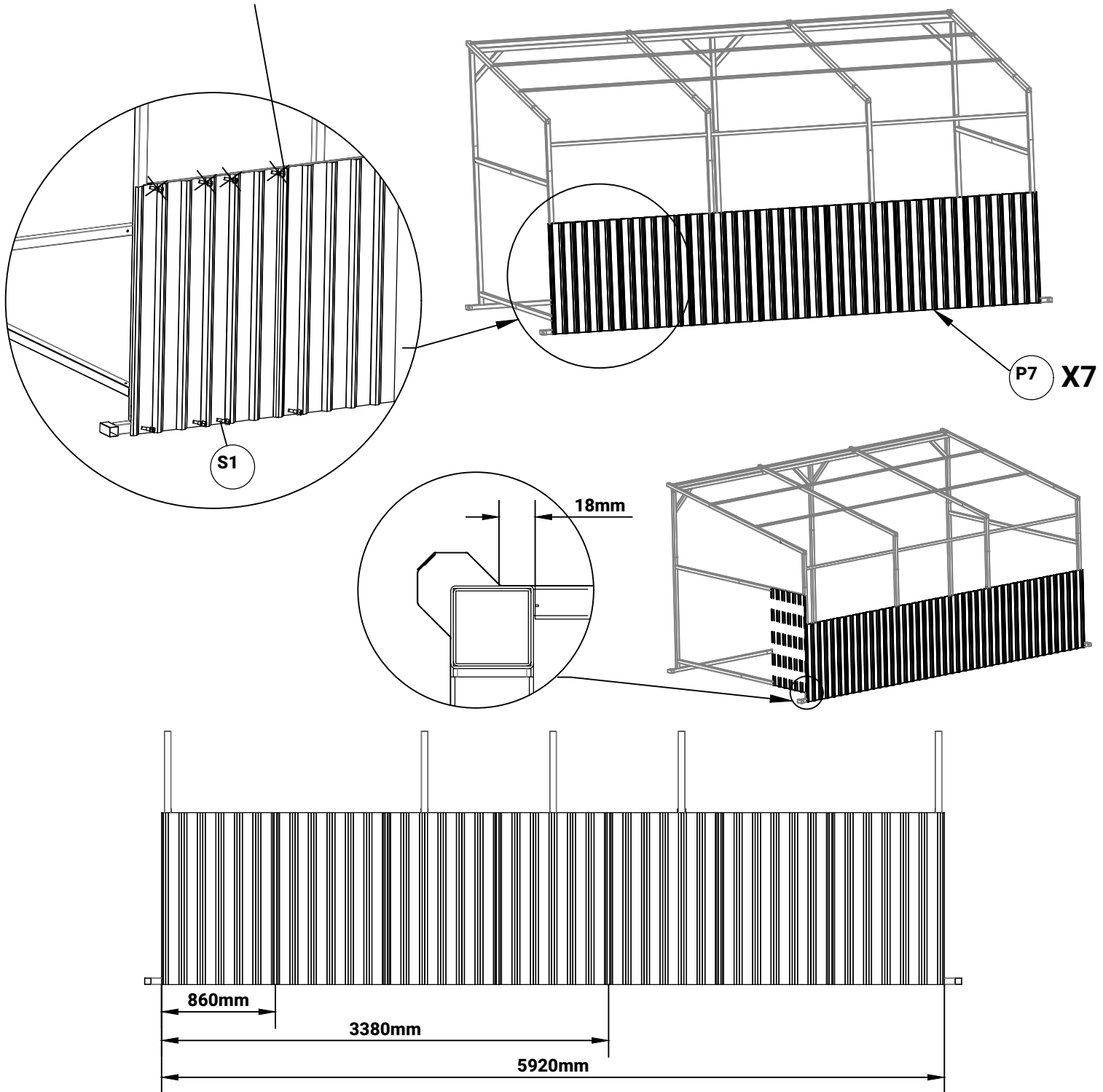

Step 13

<p>P1</p>  <p>X7</p>	<p>S1</p>  <p>X28</p>
---	--

 **Do not join components together at this location yet, as the screws may obstruct further assembly of the other components.**



Step 14



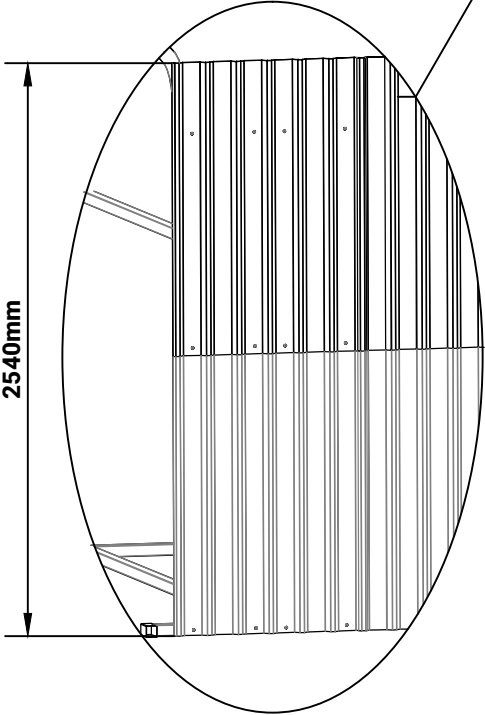
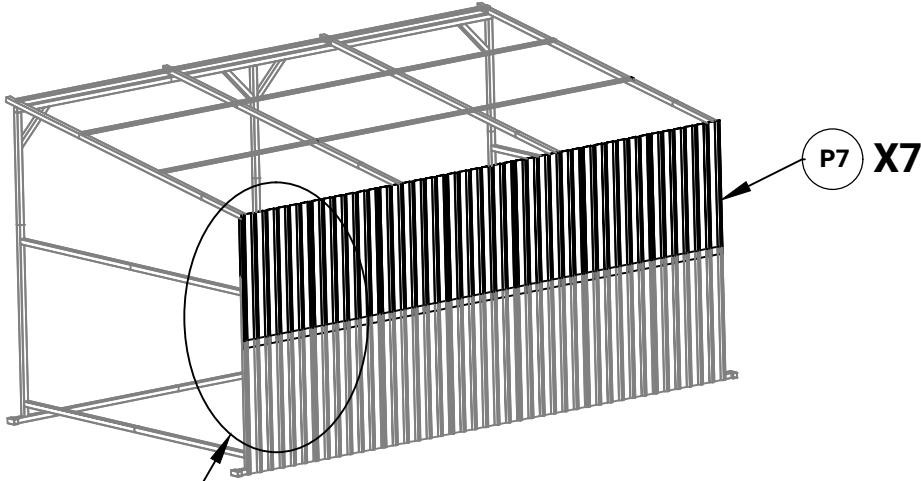



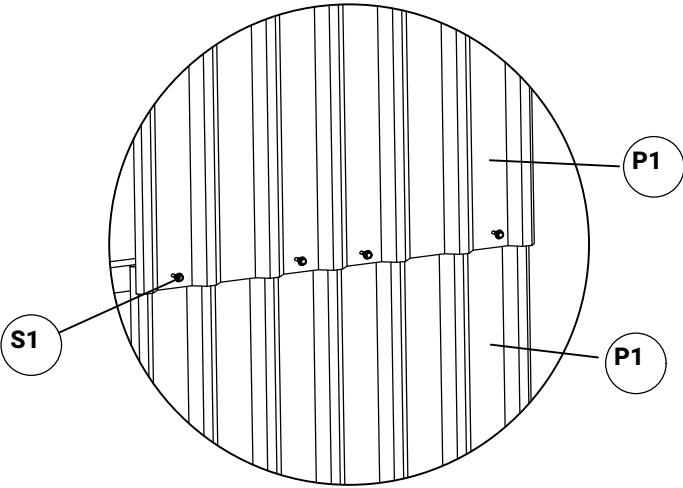



P1  X7	S1  X56
---	--



When two panels overlap, make sure upper panel covers the lower panel.





Step 15

P3 	P4A 	P5A 	P6A 	P7A 	P4B 	P5B 	P6B 	P7B 	S1 
X8	X1	X1	X1	X1	X1	X1	X1	X1	X96

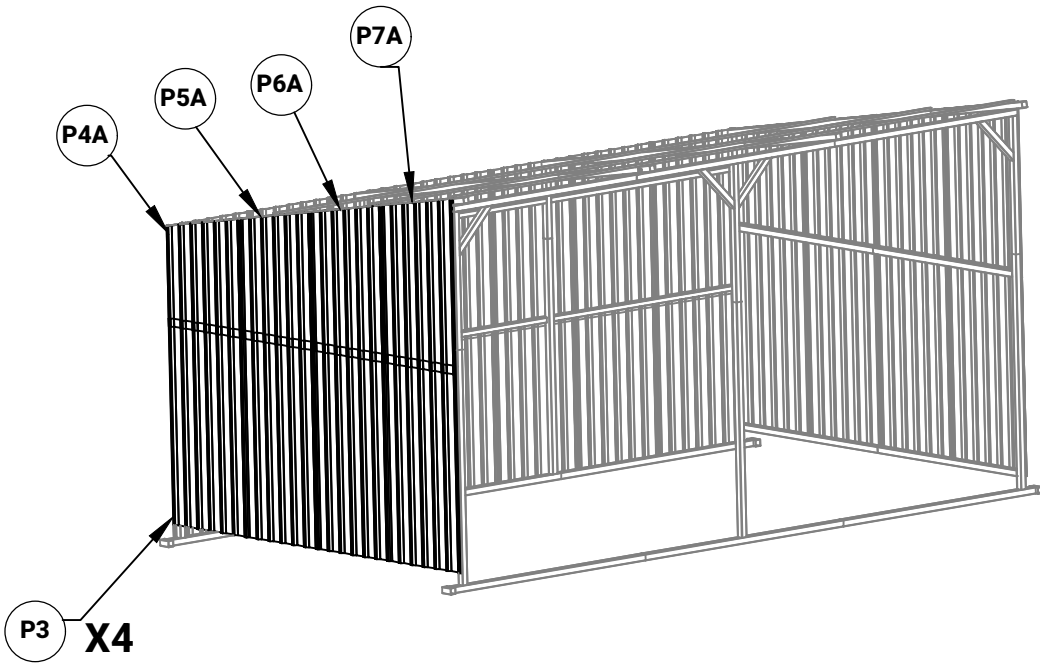
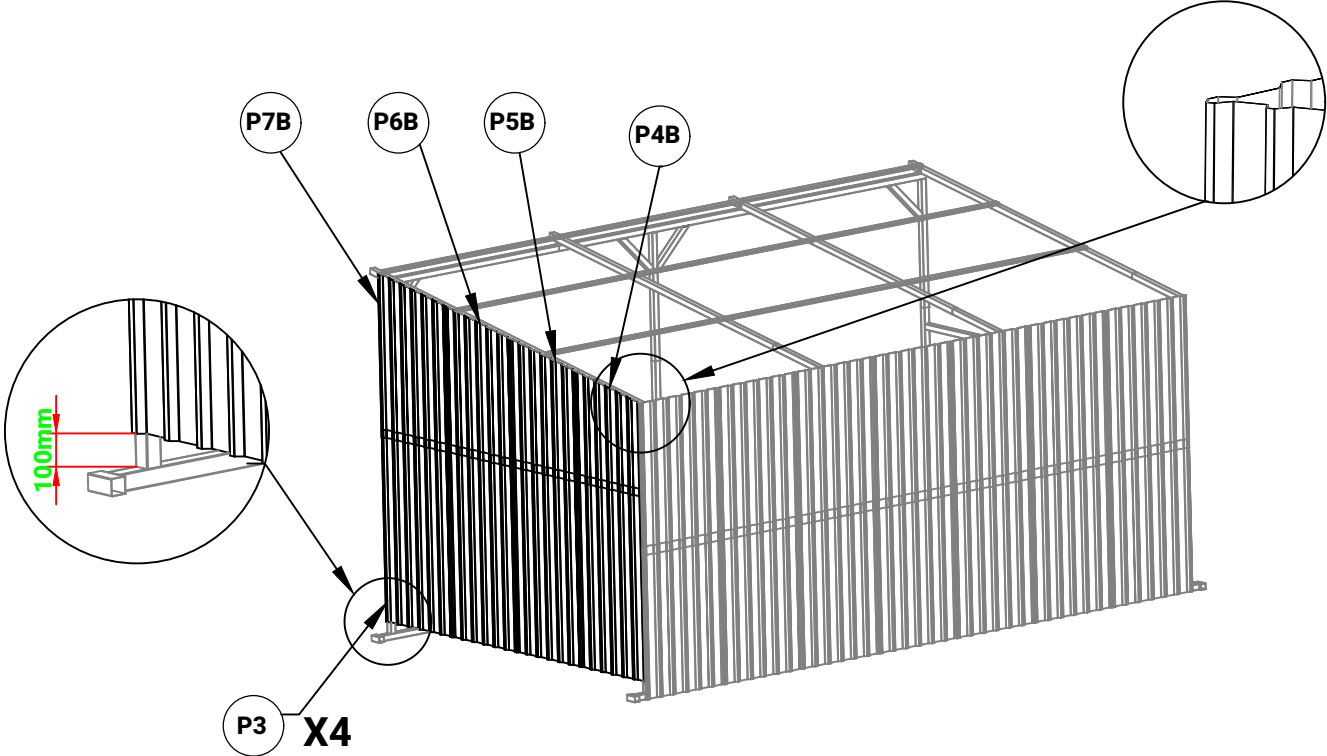
 When two panels overlap, make sure upper panel covers the lower panel.



Step 16

ZL1	ZU1	S1
		
X4	X3	X28

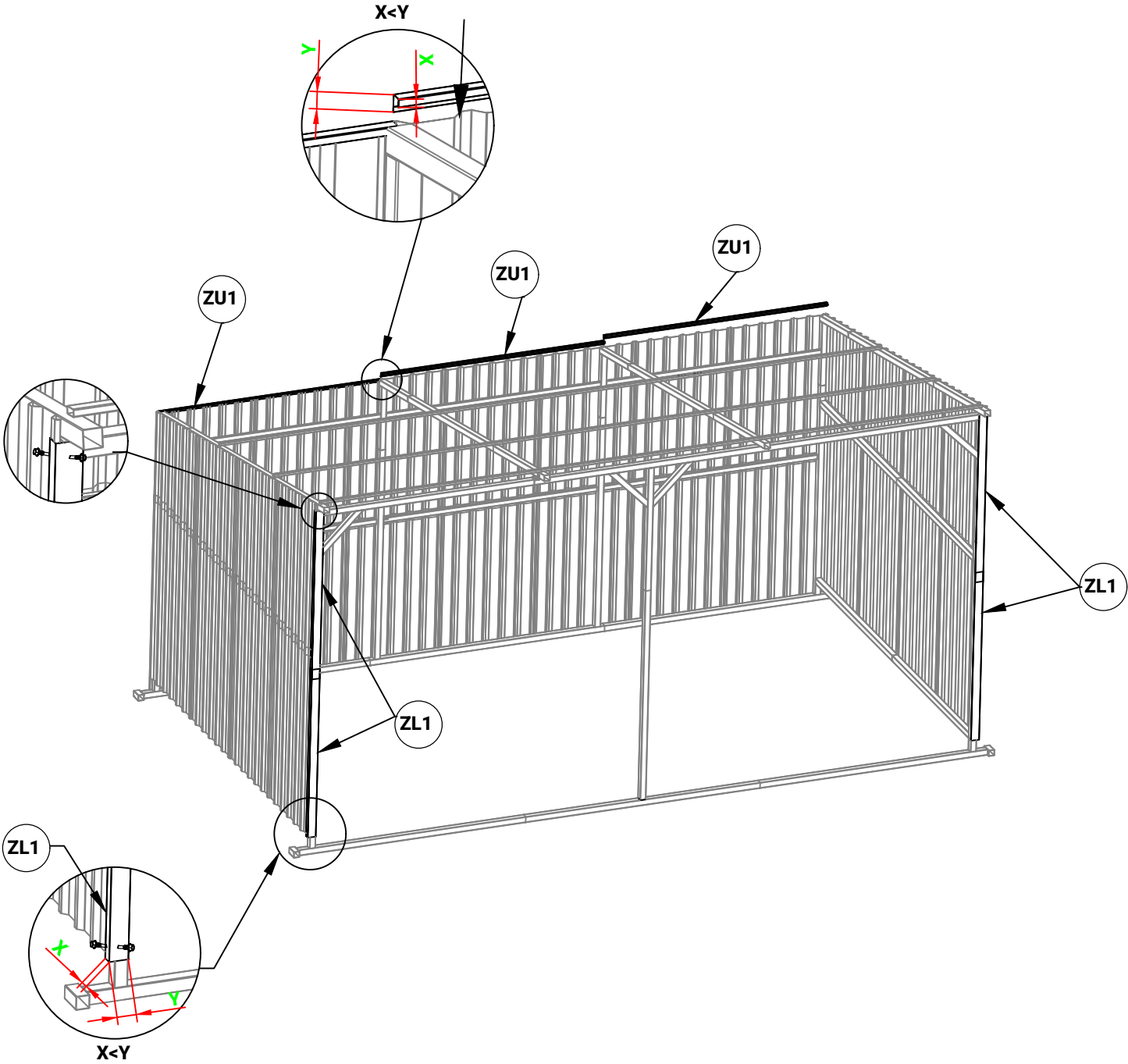

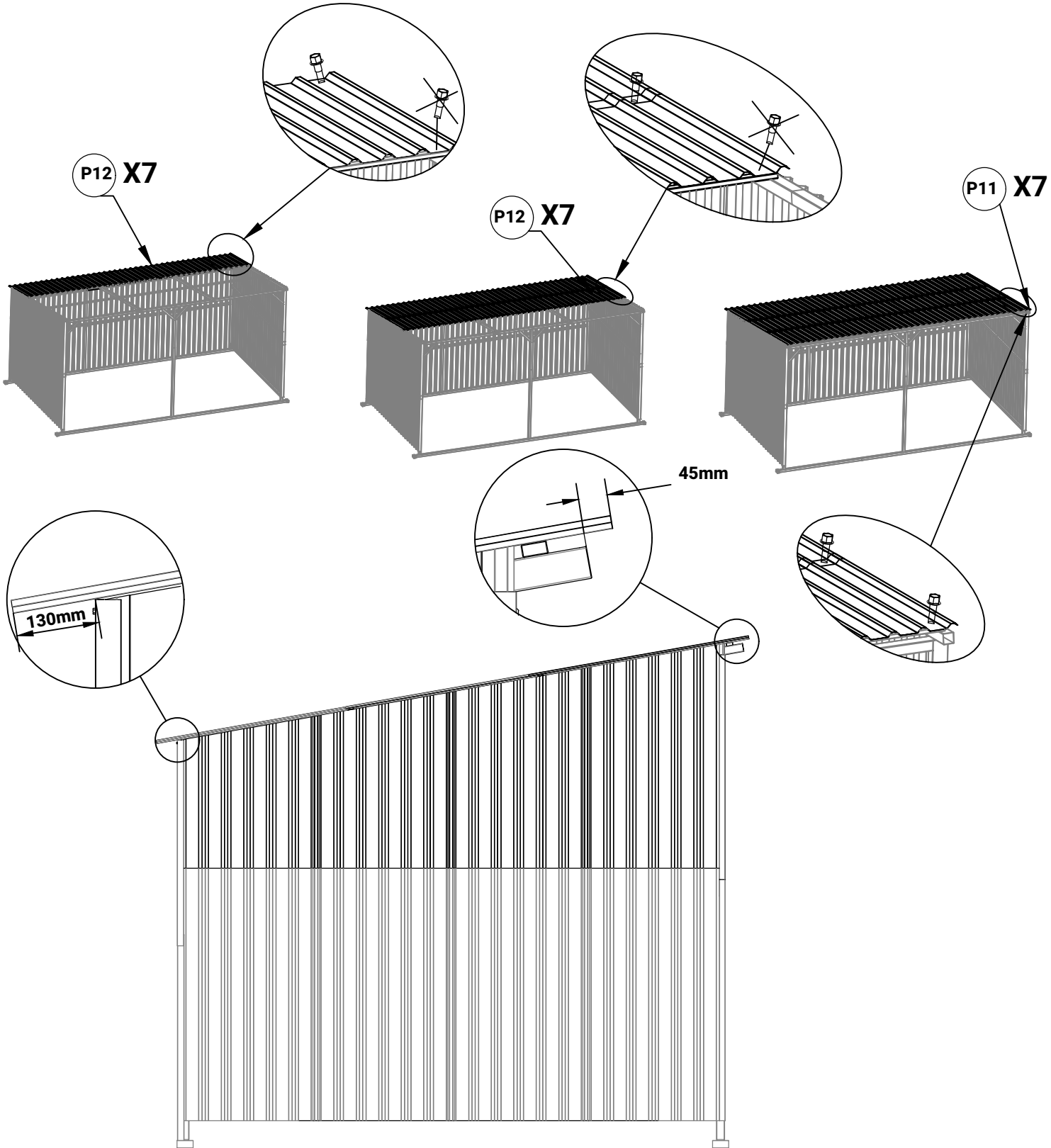

Step 17

P11	P12	S1
X7	X14	X112



Step 18

ZL2	ZL3	S1
		
X6	X4	X24

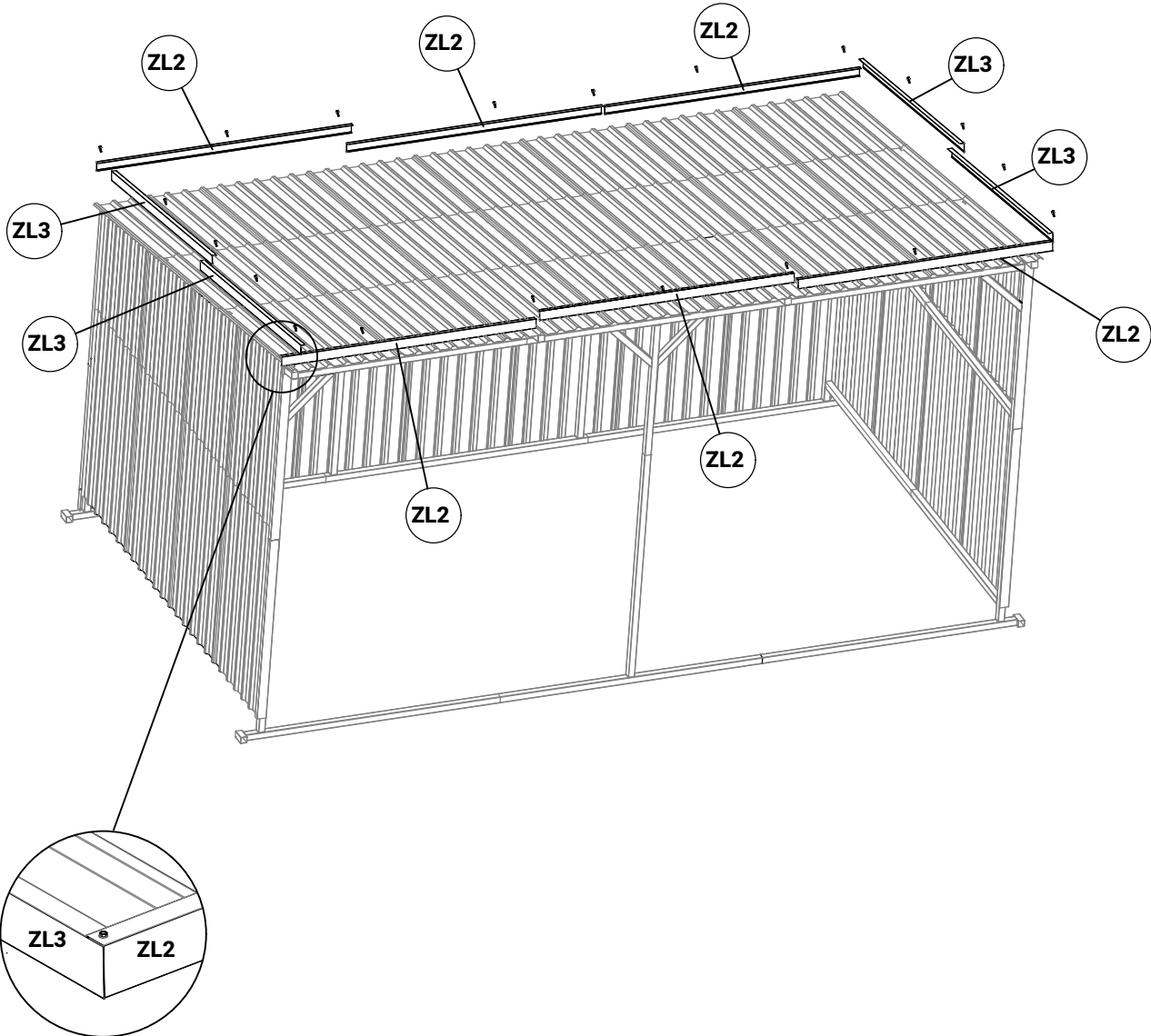

Step 19

K9



X8

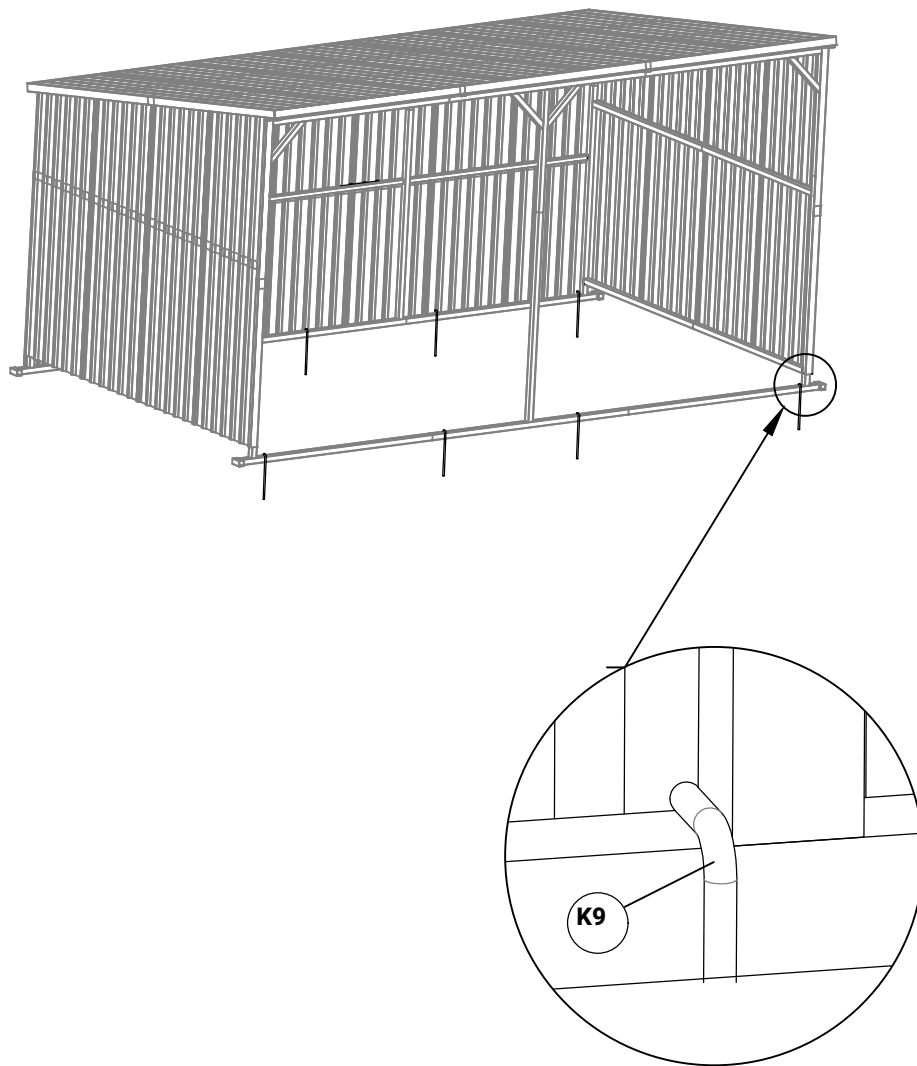





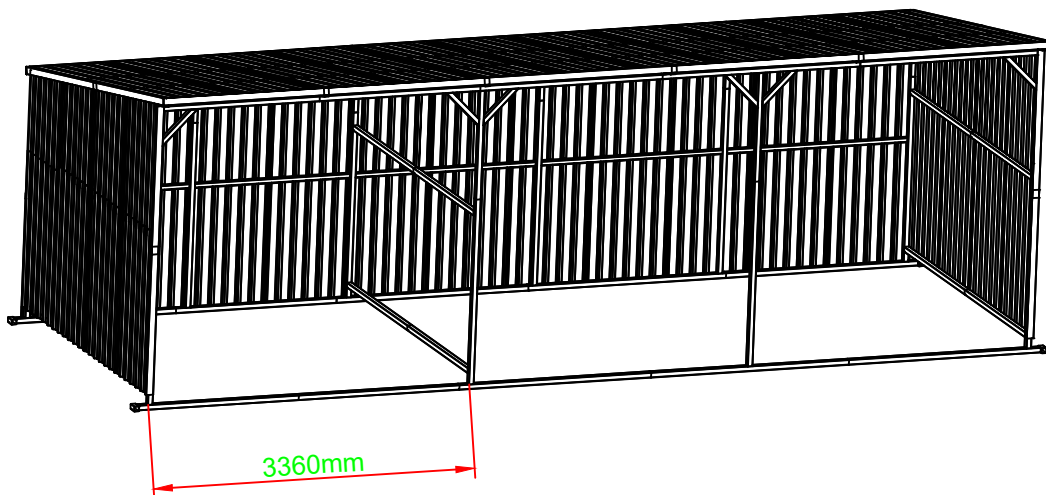



OPTIONAL



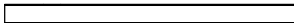



The following are the installation instructions for the module section. Please note that the module section needs to be purchased separately. Increase the length of each module by 3360mm.





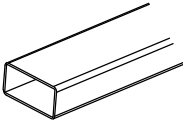
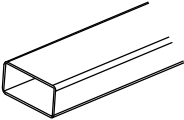

PARTS LIST

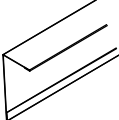
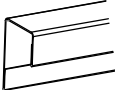
Item no.	Reference Image	Specification	Qty.
A2		100mm	2
A5		1096mm	1
A6		500mm	2
A7		1641mm	4
A8		1867mm	3
A9		1100mm	2
A10		1838mm	2
A13		617mm	2
A14		566mm	2

PARTS LIST

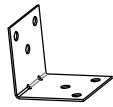
Item no.	Reference Image	Specification	Qty.
A15		1680mm	4
J1-1		150mm	1
B4		1630mm	4
B5		1680mm	6
P1		1300*885mm	8
P11		1390*885mm	4
P12		1260*885mm	8
ZL5		1730mm	4
ZU1		1966mm	2

PARTS LIST



Item no.	Reference Image	Specification	Qty.
K6		40*40mm	3
S1		M5*20	154
M1		50*50	2
K9		300mm	4

Step 1

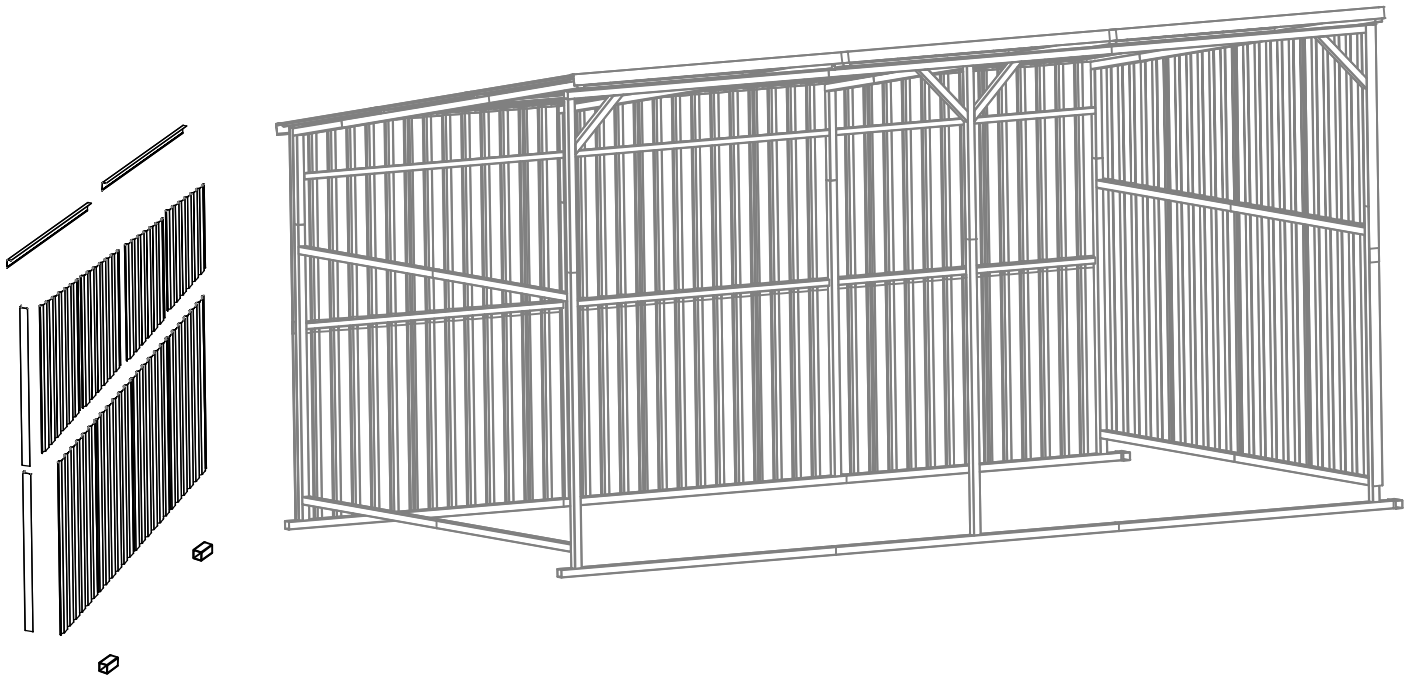
You need to dismantle some parts of the side wall.





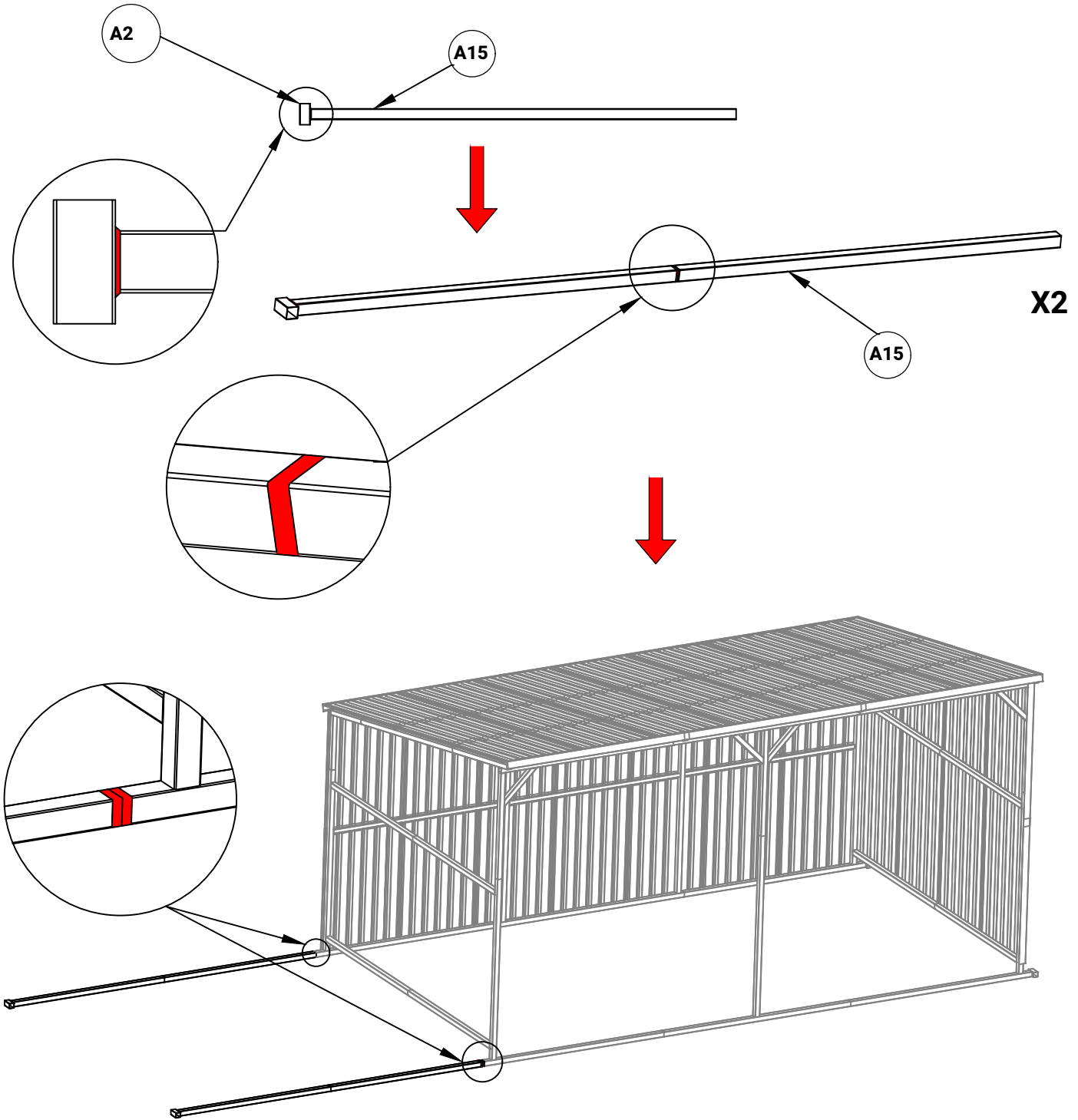

Step 2

A15	A2
	
X4	X2



Step 3

A8	A5	A7	A14
			
X2	X1	X4	X1

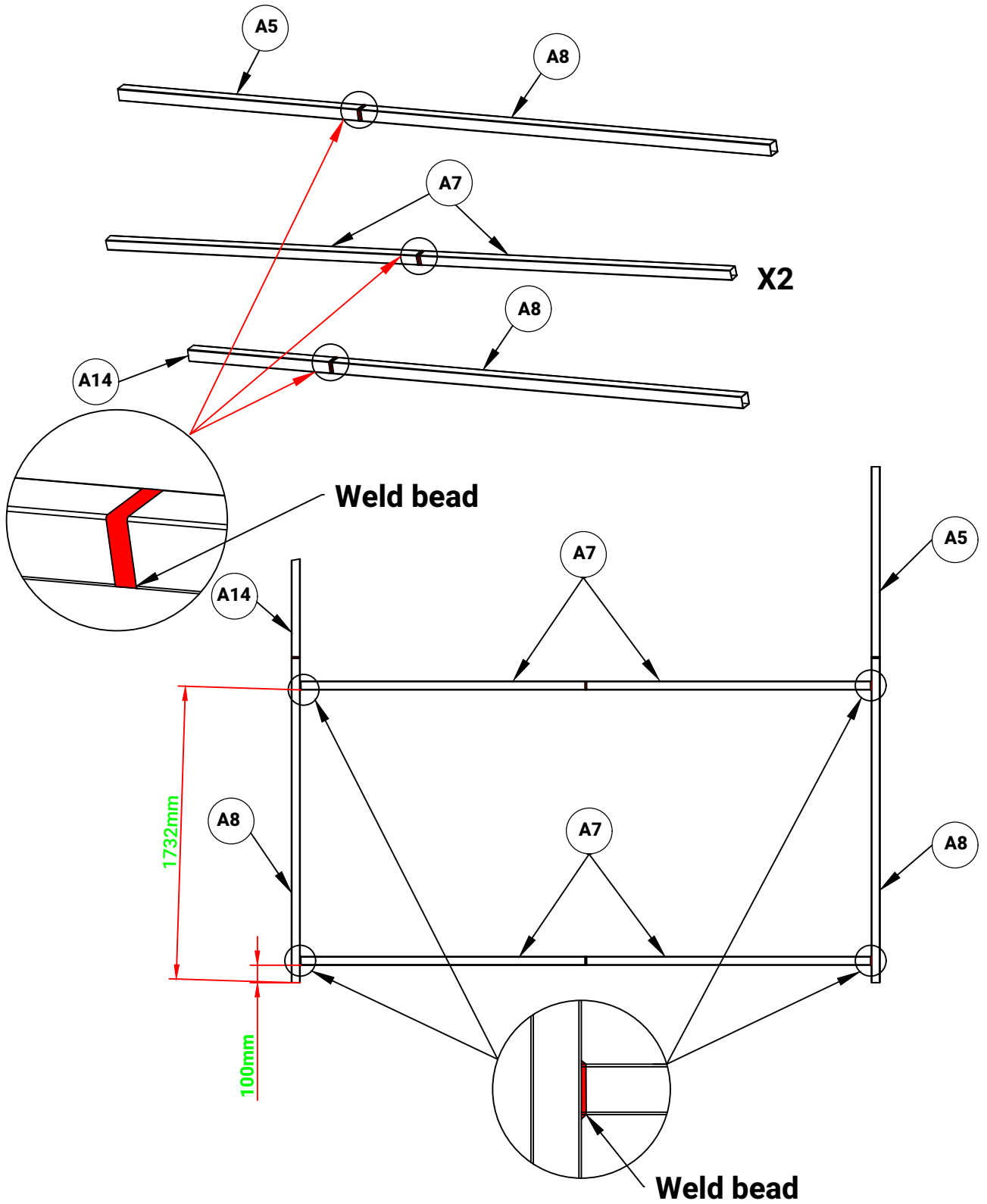



Step 4

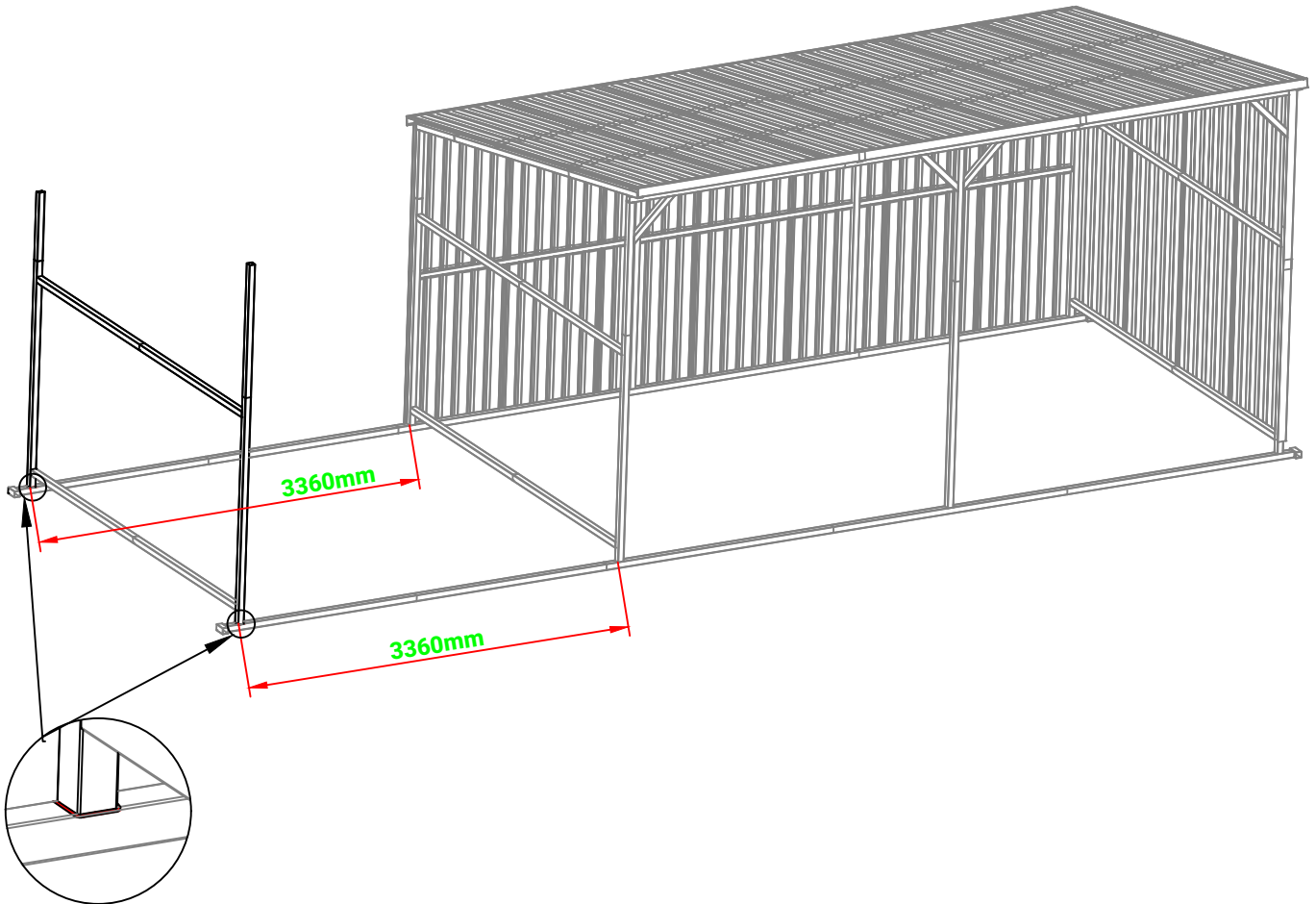

X1



Step 5

A15	S1
	
X2	X4

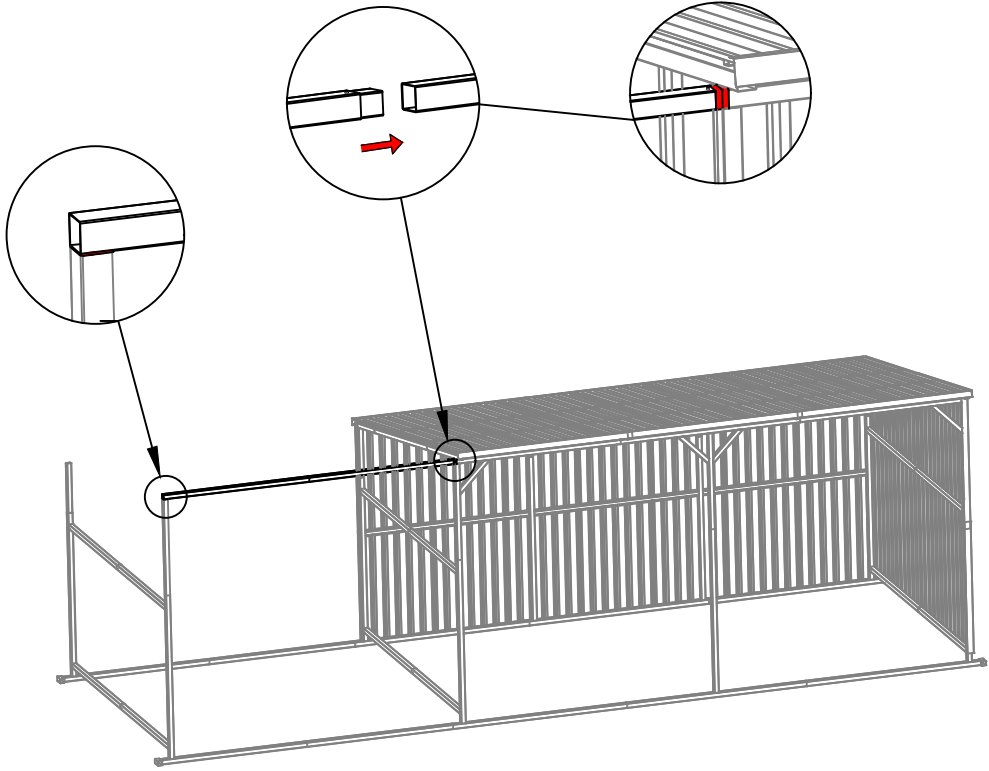
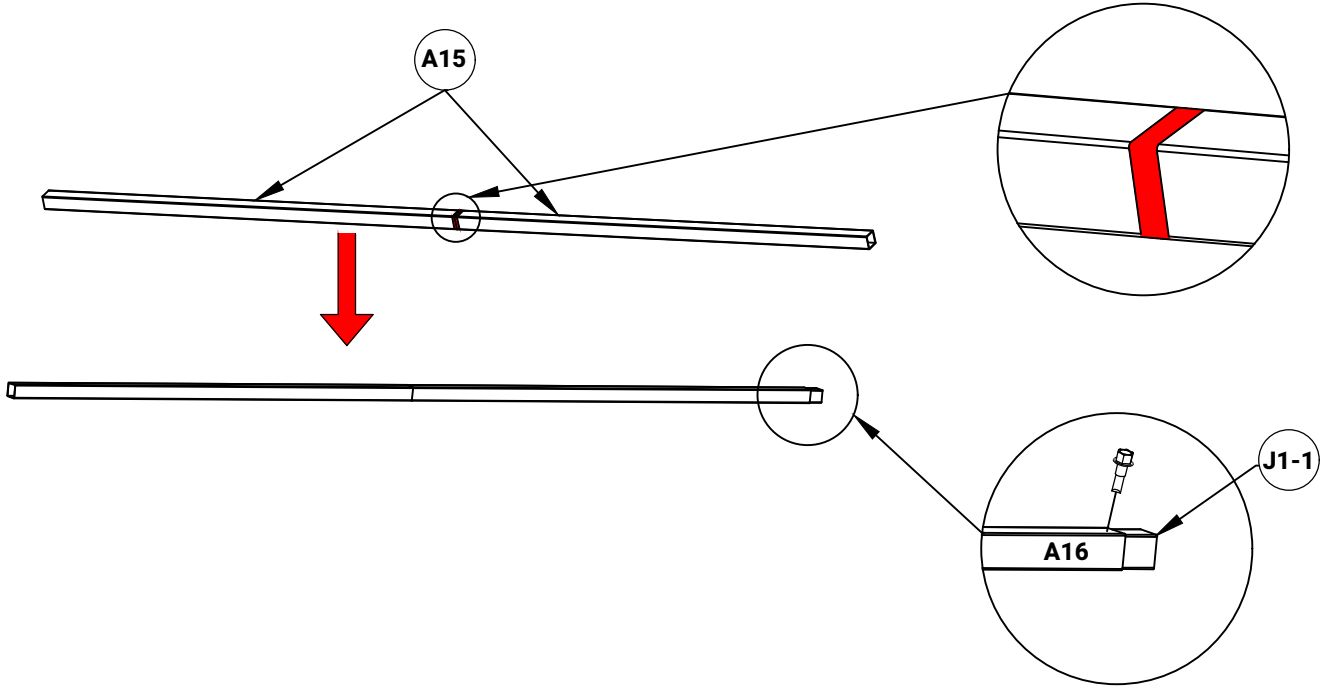



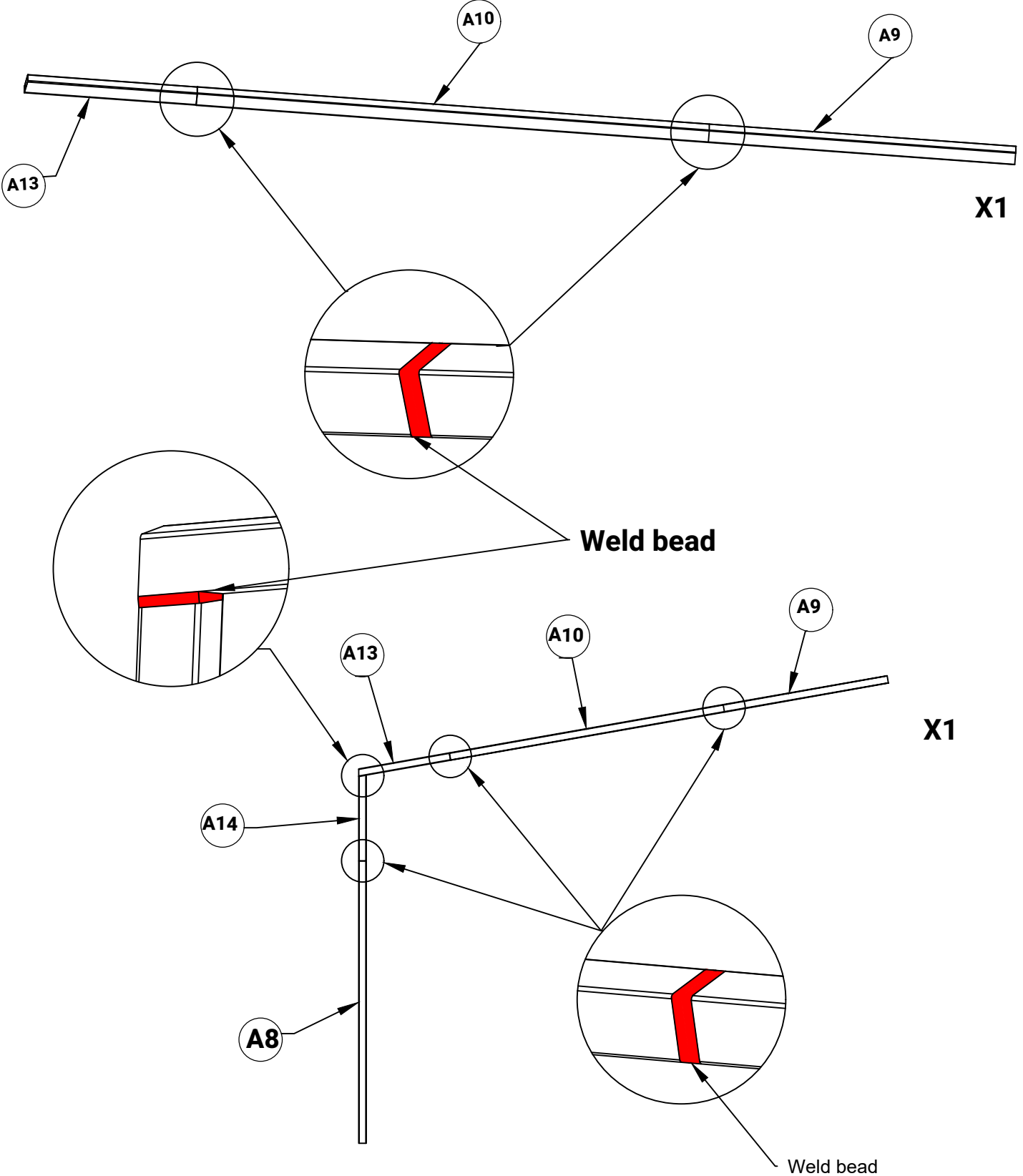

Step 6

A9	A10	A13	A14	A8
X2	X2	X2	X1	X1

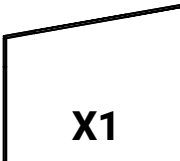

Step 7

 X1	 X1	 K6 X3	 S1 X18	 M1 X2
--	--	---	--	---

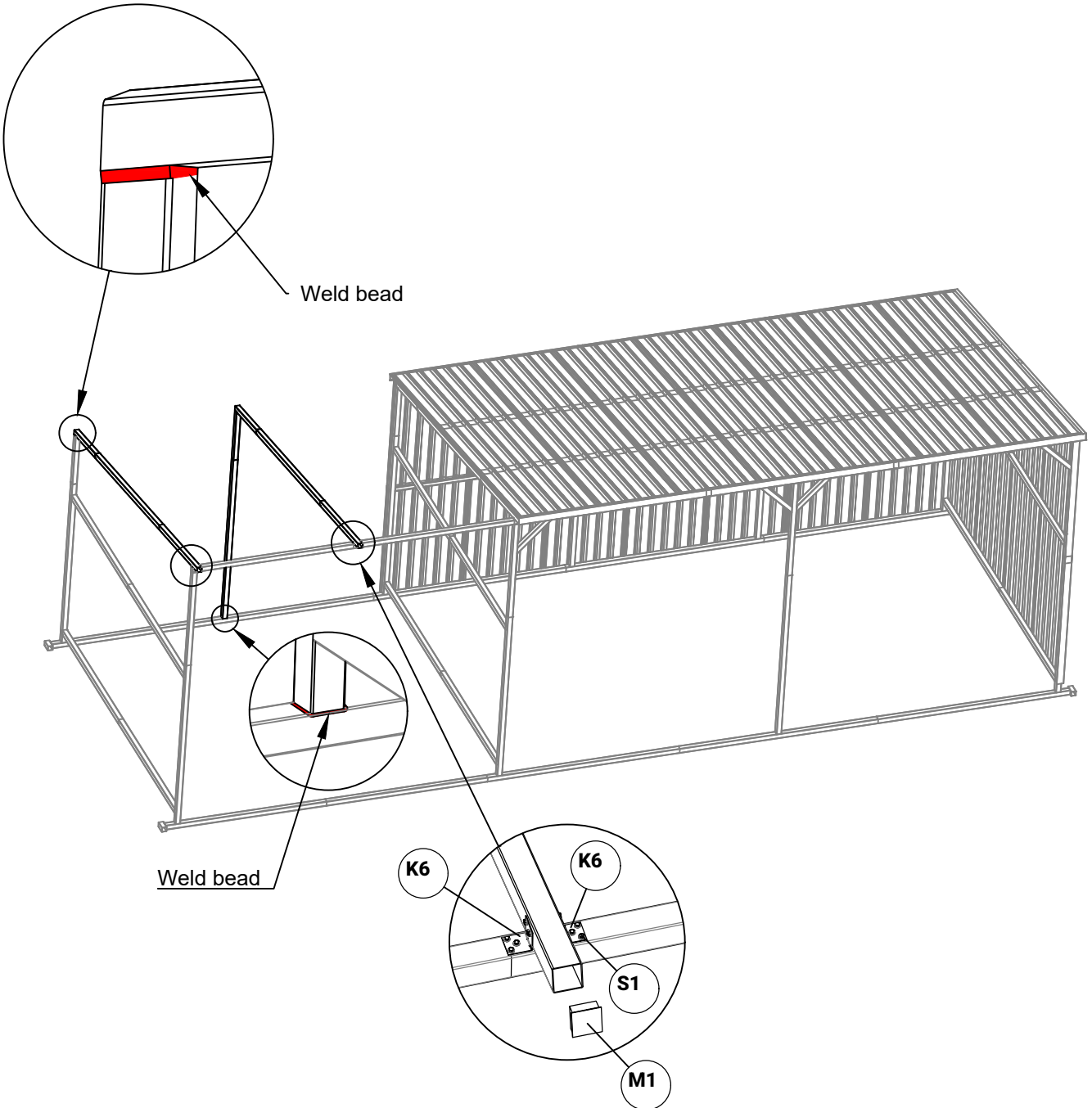

Step 8

A6



X2

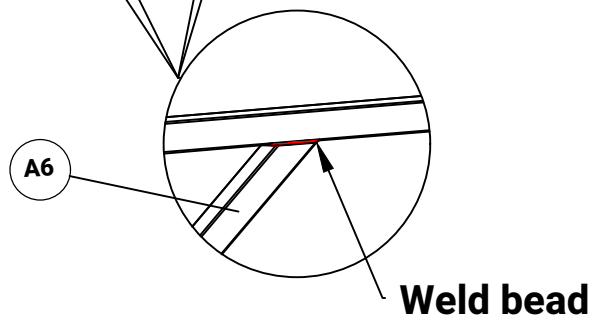
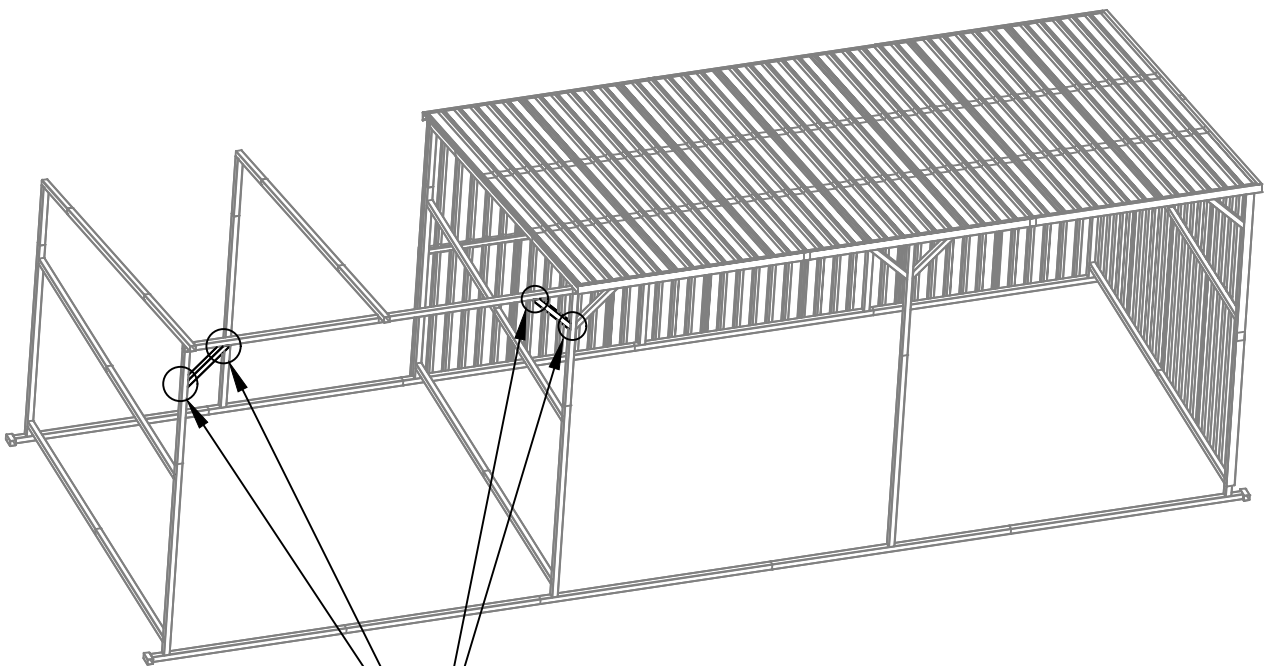

Step 9

B4



X4

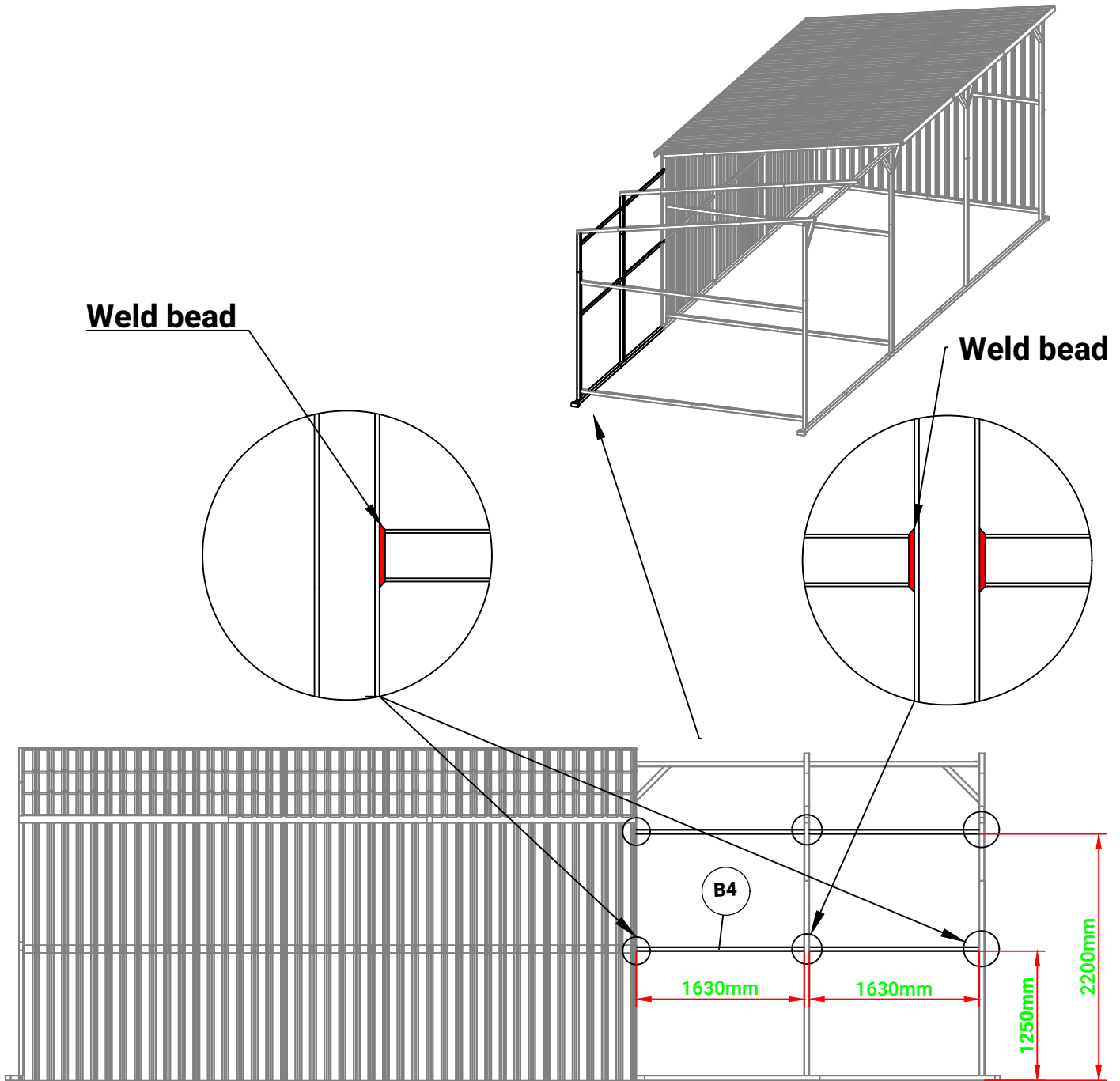

Step 10



B5

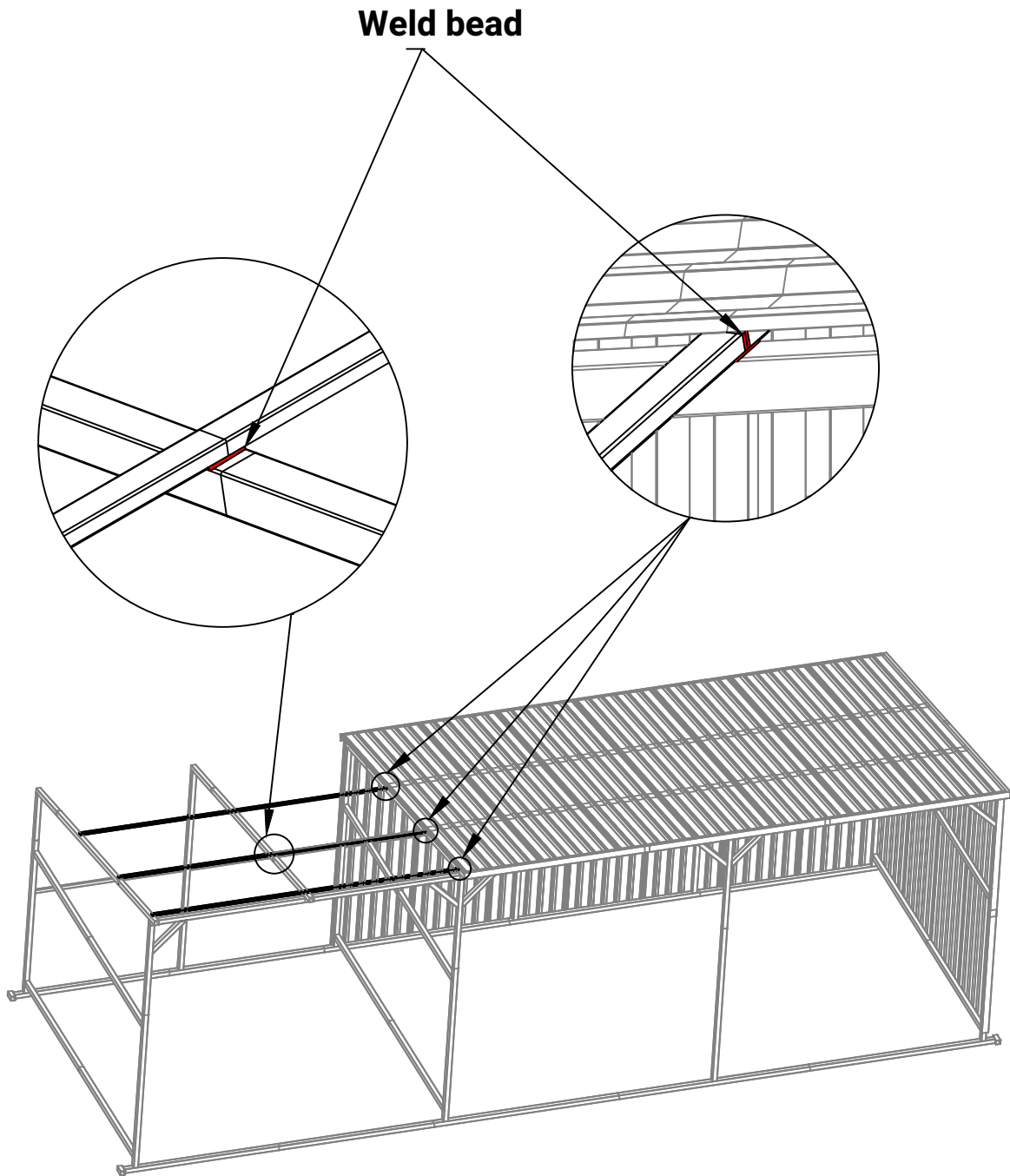

X6



Step 11

P1  X8	S1  X48
---	--

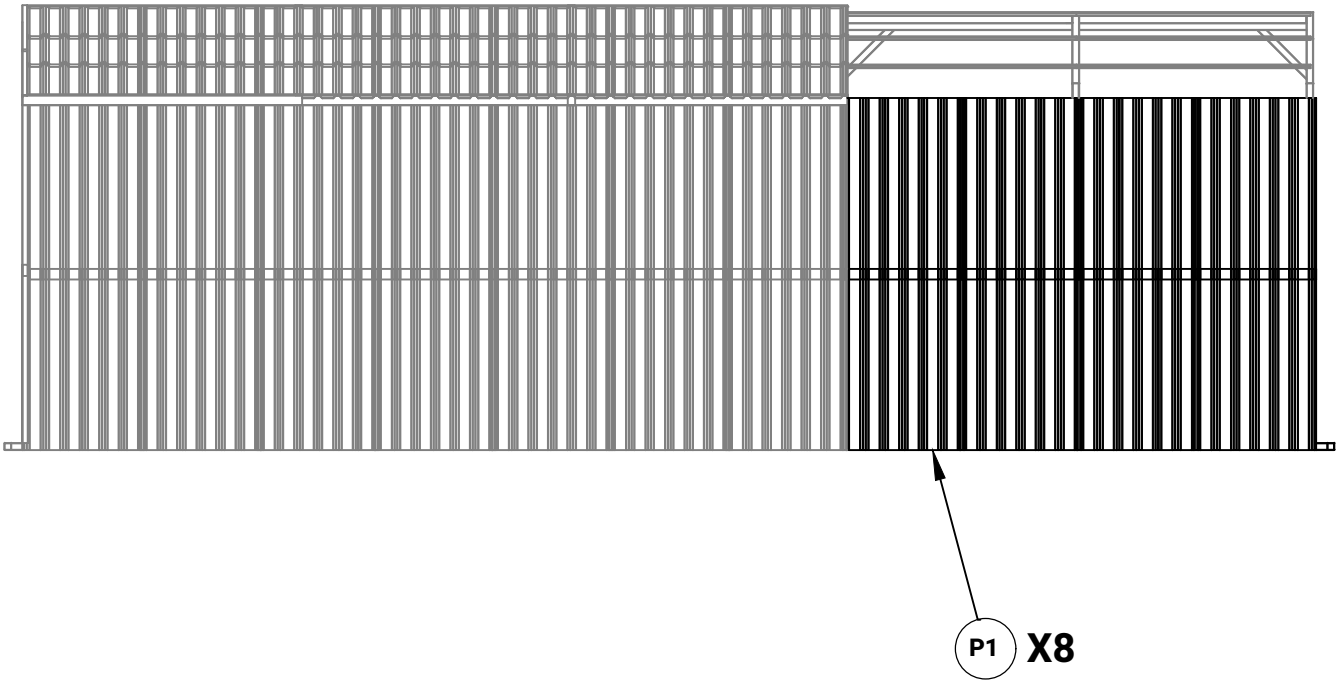
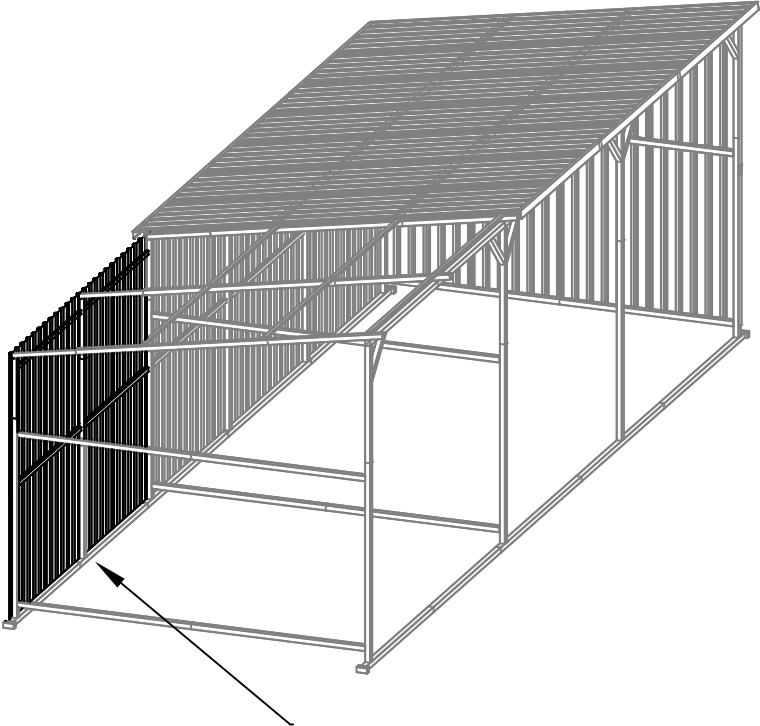

Step 12

ZU1



X2



S1

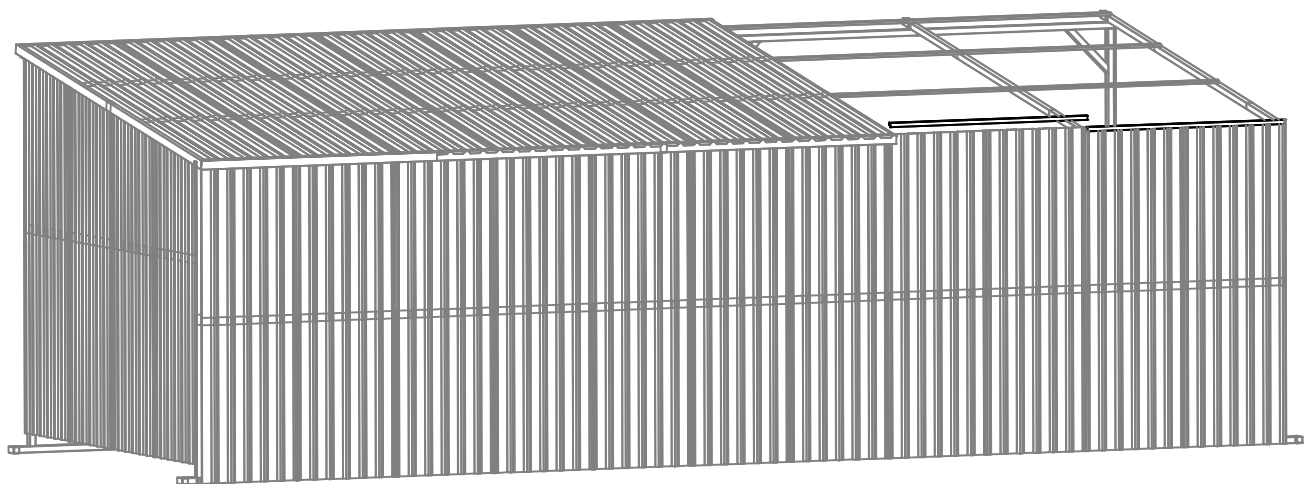

X8



Step 13

P11  X4	P12  X8	S1  X64
--	--	--

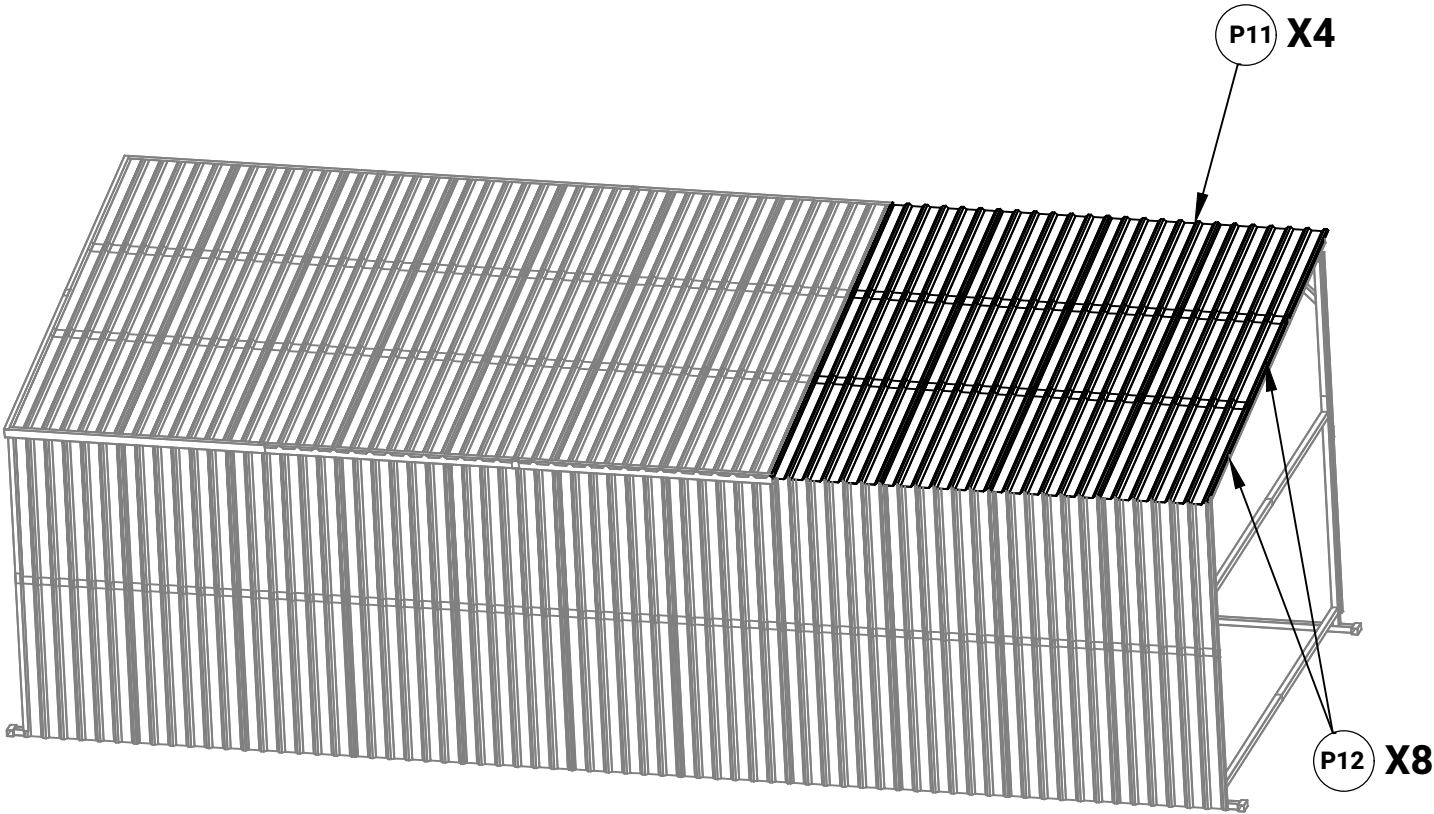

Step 14

ZL5



X4

S1



X16

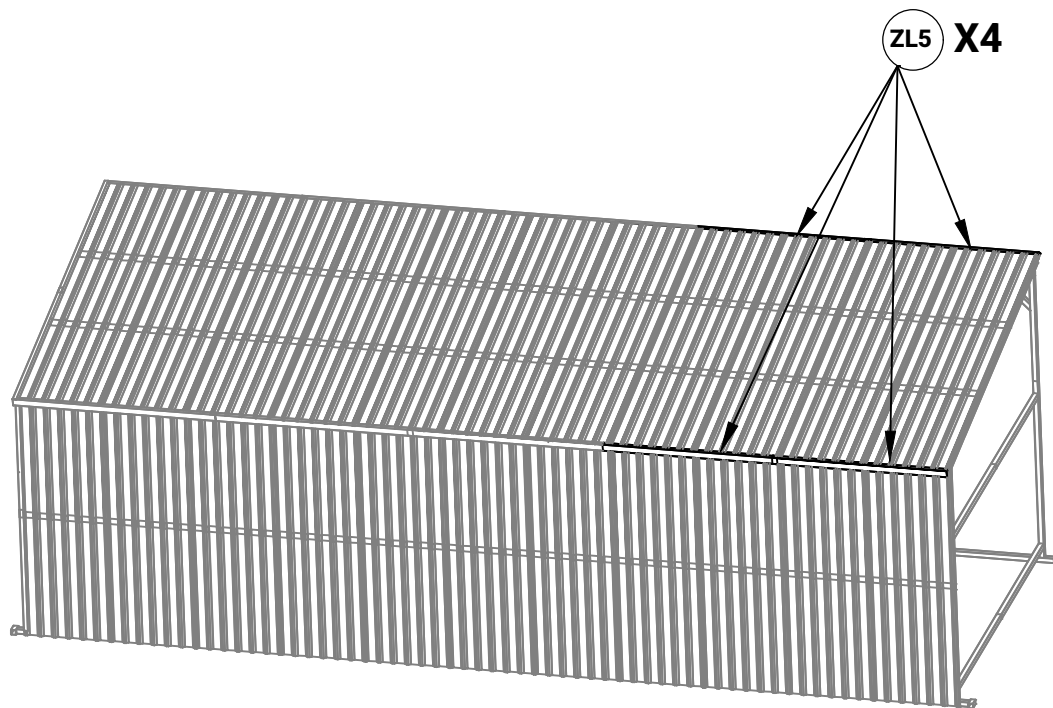

Step 15



X1

K9



X4

Reinstall the parts of the side wall.

