

12' X 20' METAL GARAGE CARPORT SHED

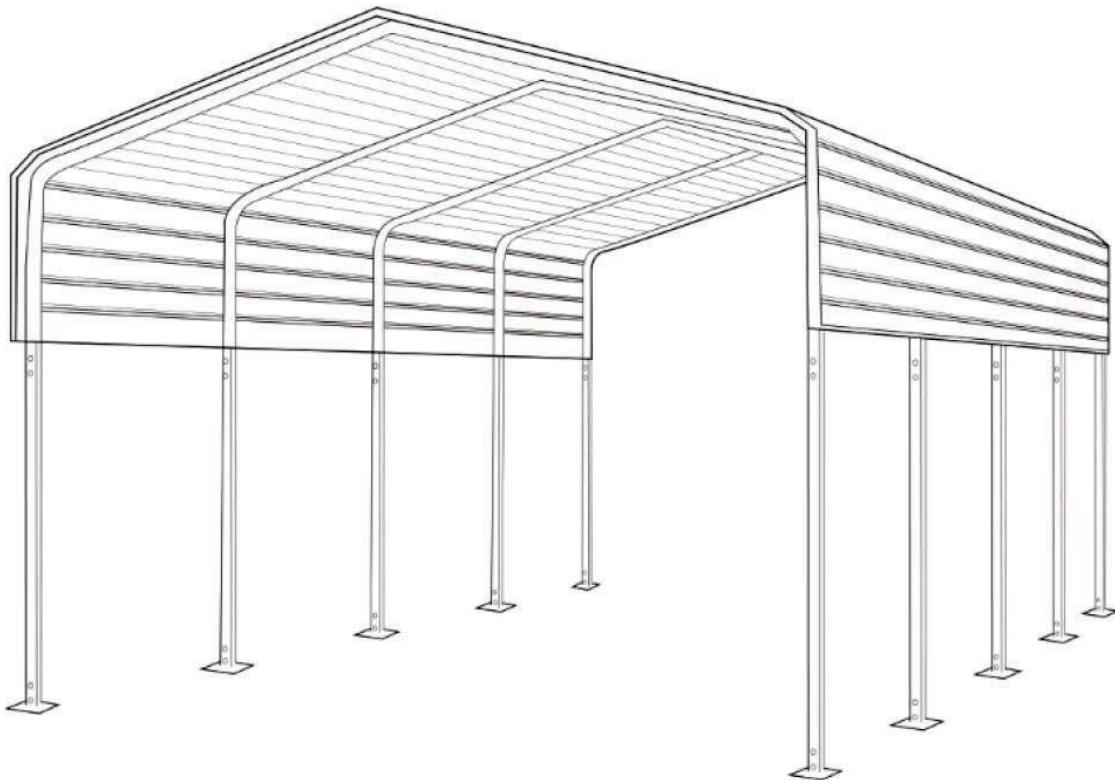

- Please read and understand the product manual completely before assembly
- Check against the parts list to make sure all parts are received
- Wear proper safety goggles or other protective gears while in assembly
- Do not return the product to dealer. They are not equipped to handle your requests.

Missing parts or have questions on assembly?
Please call: 1-877-761-2819 or email: cs@tmgindustrial.com

Main Specifications :

- Overall assembled size : W3.66 x L6 x H2.9 (m) / 12 x 19.7 x 9.5 (ft)
- Width : 3.66 m / 12ft
- Length : 6 m / 19.7 ft
- Ridge peak height : 2.9 m / 9.5 ft
- Shoulder wall clearance height : 2.4 m / 7.9 ft

Prior to assembly

Please read the instructions carefully before installation. It is important to follow your local safety regulations and industry standards during installation. Regulations may include but are not limited to:

- Safety helmets, protective eyewear, and clothing
- Safety harnesses for all elevated workers
- Proper ladder, cage, and safety operation















Check all components and parts before installation. All parts are marked with a part number, please refer to the parts list to make sure you have all parts.









Choose a day with low or no wind to install, assembly is hard in heavy wind. Do not make any alterations to the structure. Do not hang any weights on the frame during installation, including parts. We are not responsible for any damages or injuries caused by inappropriate installation, unauthorized modifications or extreme weather.

This building is not intended for human occupancy.

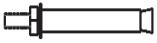
It is recommended to tape or add foam/rubber on the frame where joints connect and where it touches the cover. This will help extend the life span of the cover.

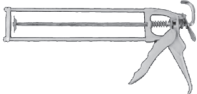
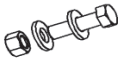
Read the following item list carefully and count the number of items to ensure that all parts are included prior to setup.

TMG-MS1220 Part List				
Parts code	Graphical	Description	Length	Qty
1		Peak arch tube	L483mm	5
2		Middle rafter tube	L1280mm	10
3		Shoulder tube	L1034mm	10
4		Sidewall tube	L1524mm	10
4A		Short casing	L198mm	30
5A		Side edge crossbar (front and rear truss)	L1570mm	4
5B		Side edge crossbar (middle truss)	L1500mm	4
6		Base plate	W150xL200mm	10
7		Metal sheet (front and rear truss)	W870xL1620mm	14
8		Metal sheet (middle truss)	W870xL1600mm	14
9		Edge protector	L2000mm	6
10		Edge buckle	L200mm	4
11		Sleeve	8mm	2
12		Steel cable mounting plate	L100mm	4

13		Anchor hook	φ16x120mm	4
14		Steel cable	φ6x3.3m	4
15		Expansion bolt	φ16 x 150mm	20
16		Waterproof silicon sealant		2
16A		Caulking gun		1
17		Hex bolt	M10x60mm	140
18		Self tapping screw	5.5x25mm	216
19		Blind rivet	φ3.2x5mm	50
20		Corner protector		4

Step 1 : Baseplate positioning and installation.

- The diagonal X and Y must be equal.

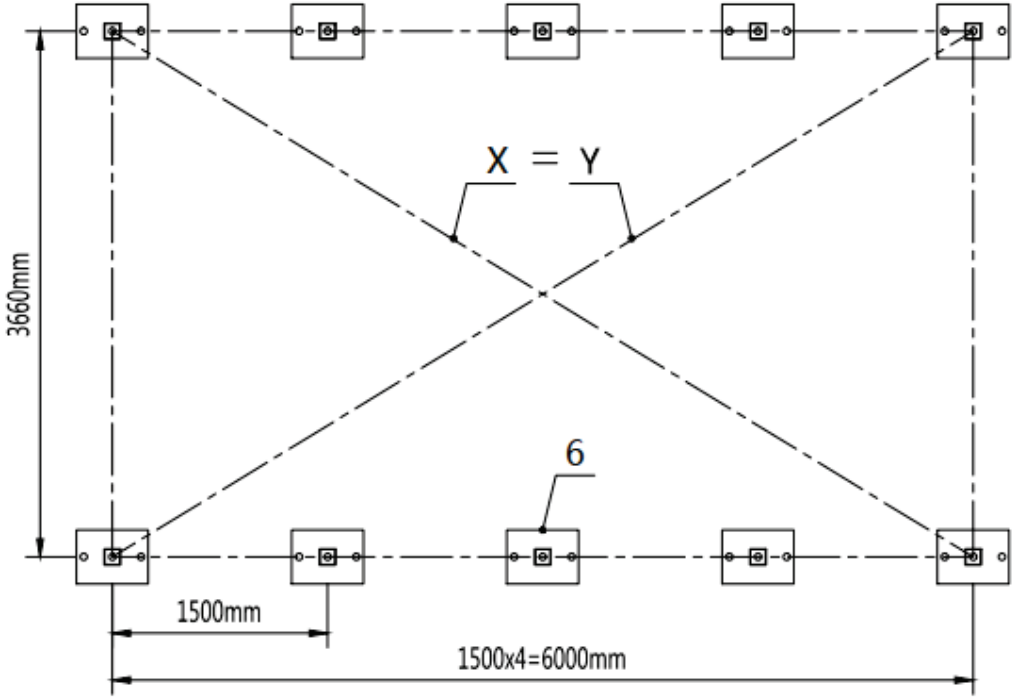

- Installation diagram of expansion bolt.

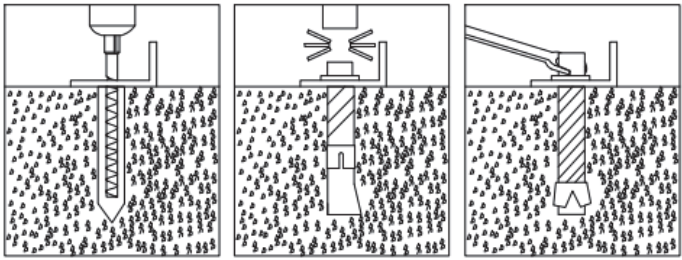

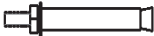
No.	Part	Qty
6		10
15		20

Step 2 : Install all trusses.

- Install front and rear trusses.

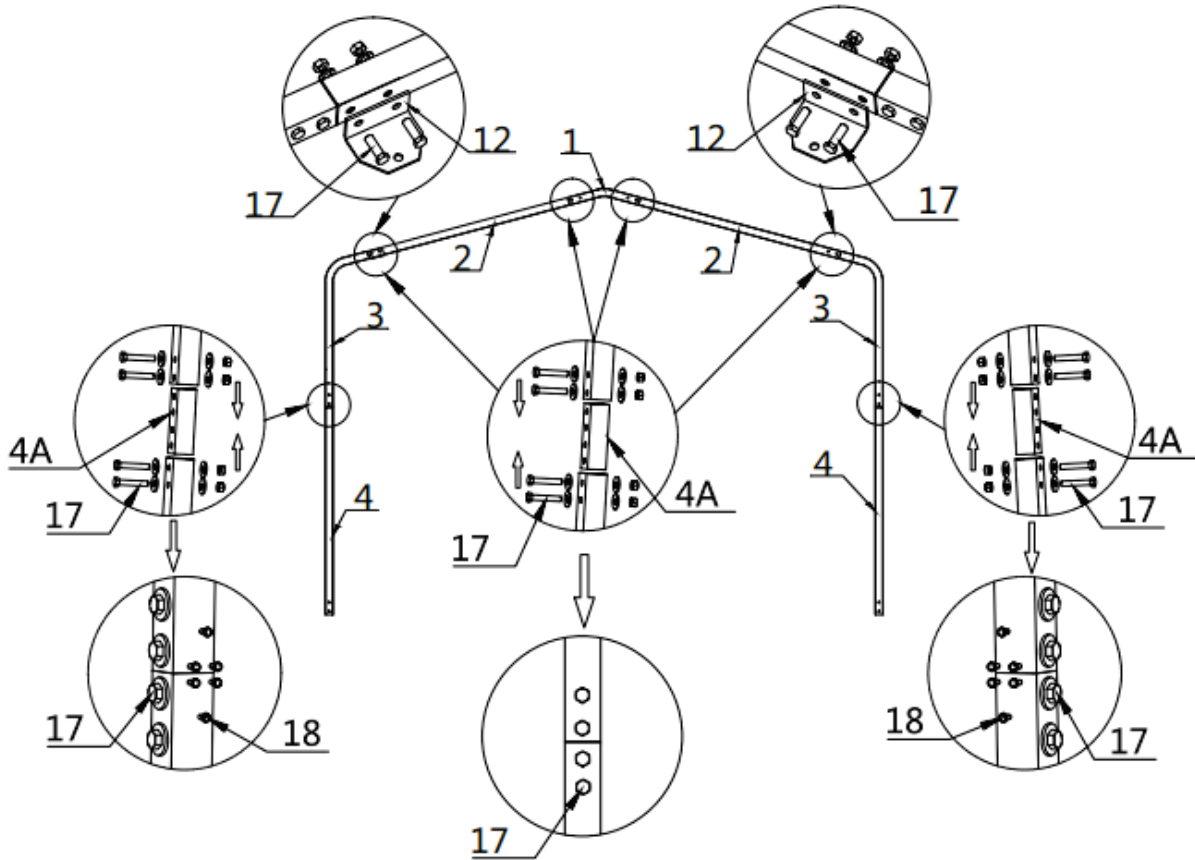

Note : use (#18) at the links of (#3) and (#4) to reinforce the inner side.

No.	Part	Qty
1		1x2
2		2x2
3		2x2
4		2x2

No.	Part	Qty
4A		6x2
12		2x2
17		24x2
18		12x2

- Install other trusses. (3 trusses)

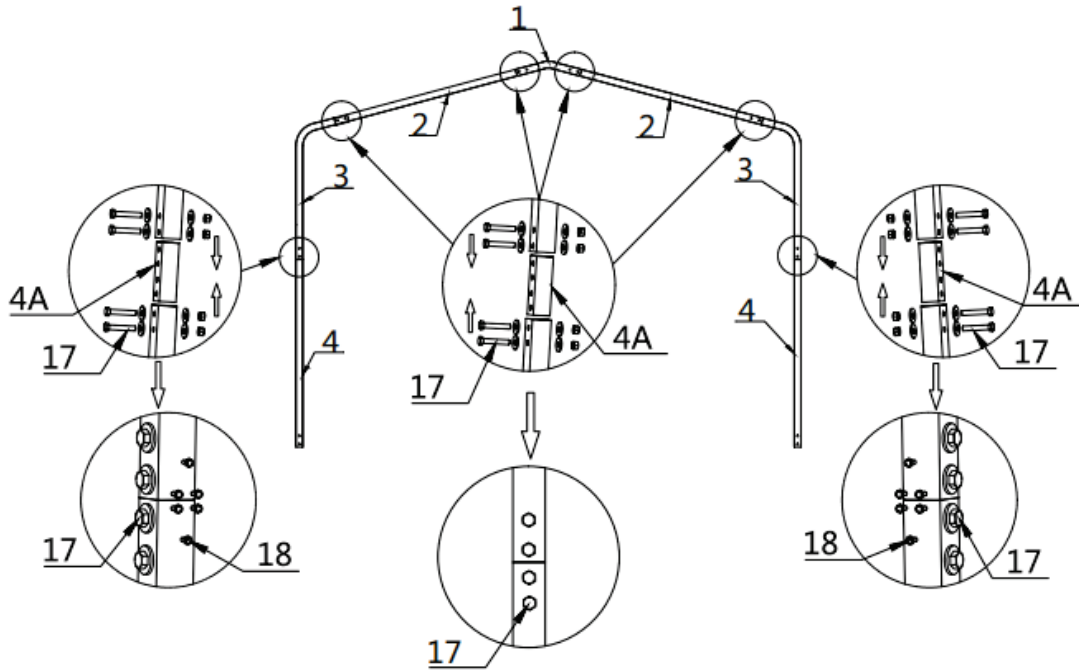

No.	Part	Qty
1		1x3
2		2x3
3		2x3
4		2x3

No.	Part	Qty
4A		6x3
17		24x3
18		12x3

- Lay down all (5) trusses on the ground as figure when the assembly is all completed and before moving to next step.

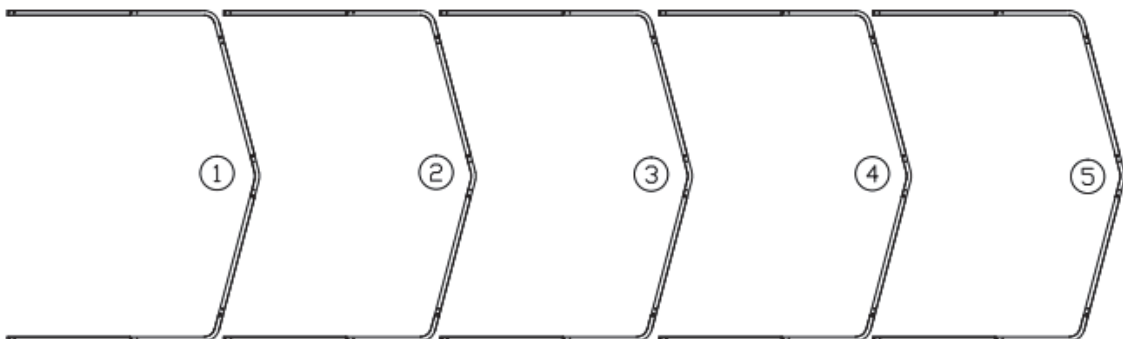

Step 3 : Put up the all trusses.

- The front and rear trusses are installed with one side of (#12) Steel cable mounting plate facing outwards.

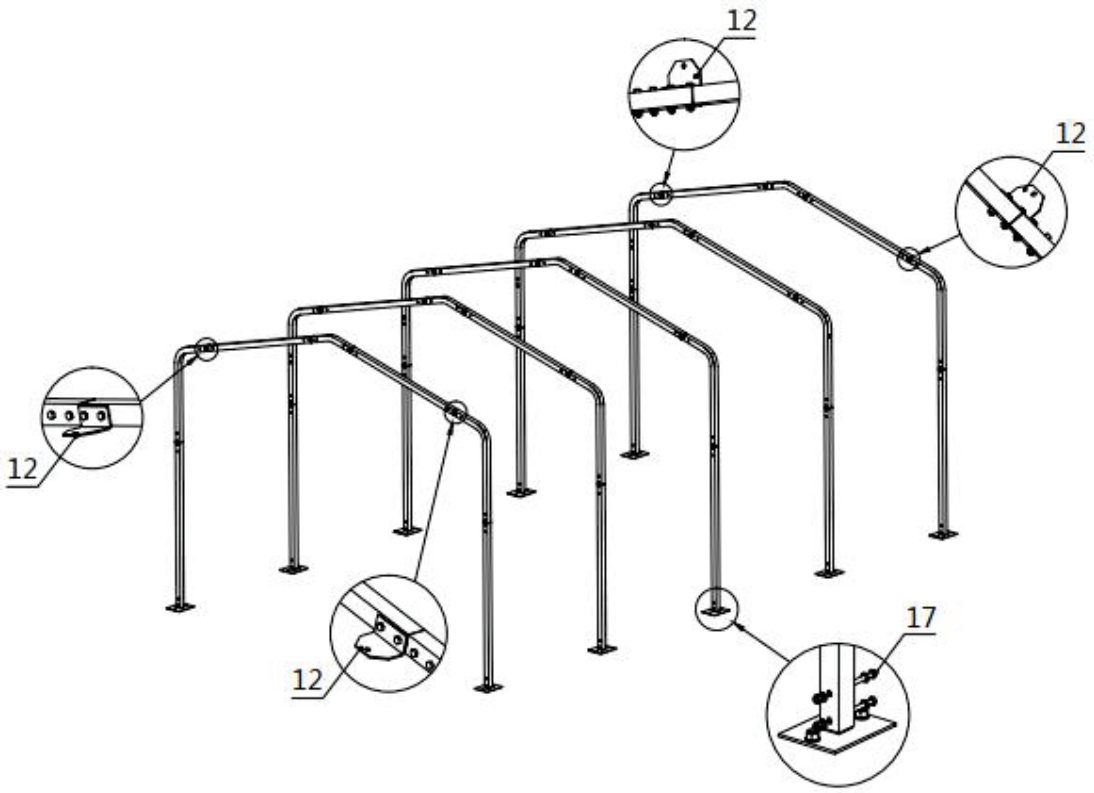

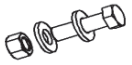

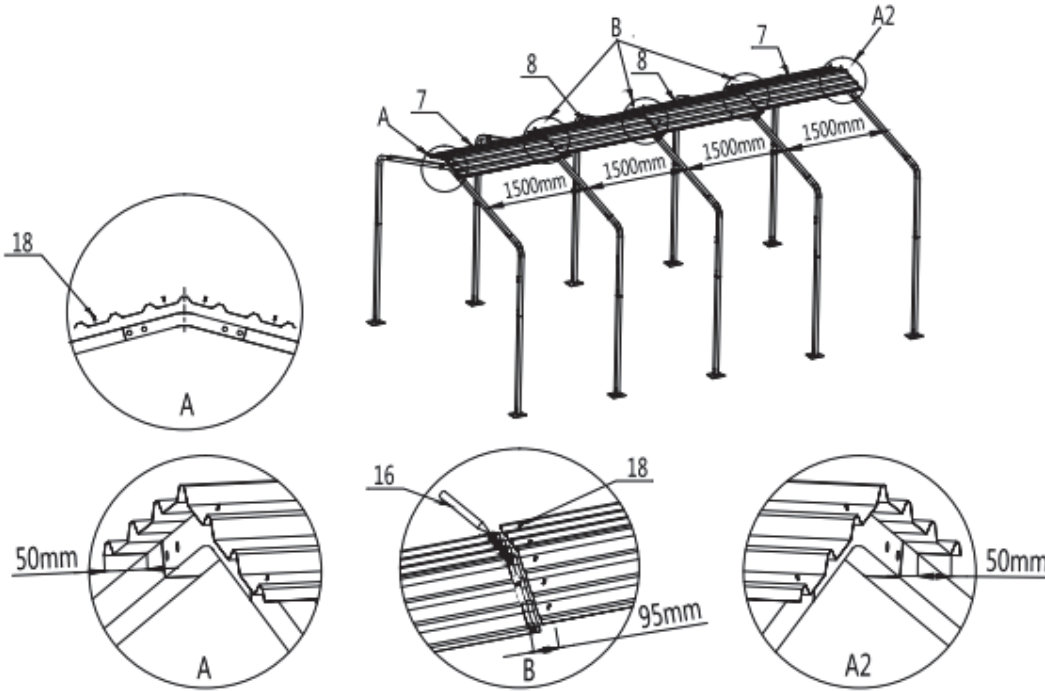

No.	Part	Qty
17		20

Step 4 : Install the color iron tile.

- Before installation, ensure that the distance between centers of each collapse is 1500mm. Install the first row of colored iron tiles from the top end. The center of the colored steel tiles must be aligned with the midpoint of the top arch tube (you can mark the center of the top arch tube with a line). The extension size of both ends is 50mm. The size of the middle cross overlap position is 95mm, and the cross overlap position needs to be coated with Waterproof silicon sealant. All color iron tiles are fixed on the truss with (#18) self tapping screws.





No.	Part	Qty
7		2
8		2

No.	Part	Qty
16		1
18		20

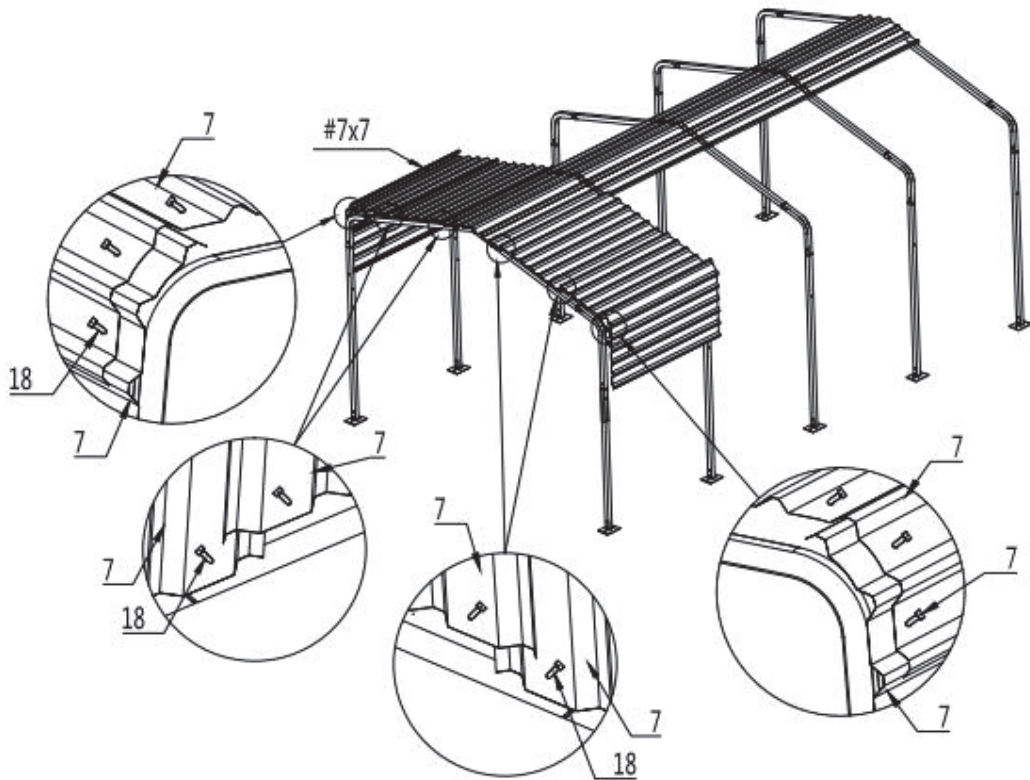

- Install the first color iron tile. Take the first colored iron tile at the top as the benchmark, ensure that both ends of each colored iron tile are aligned.



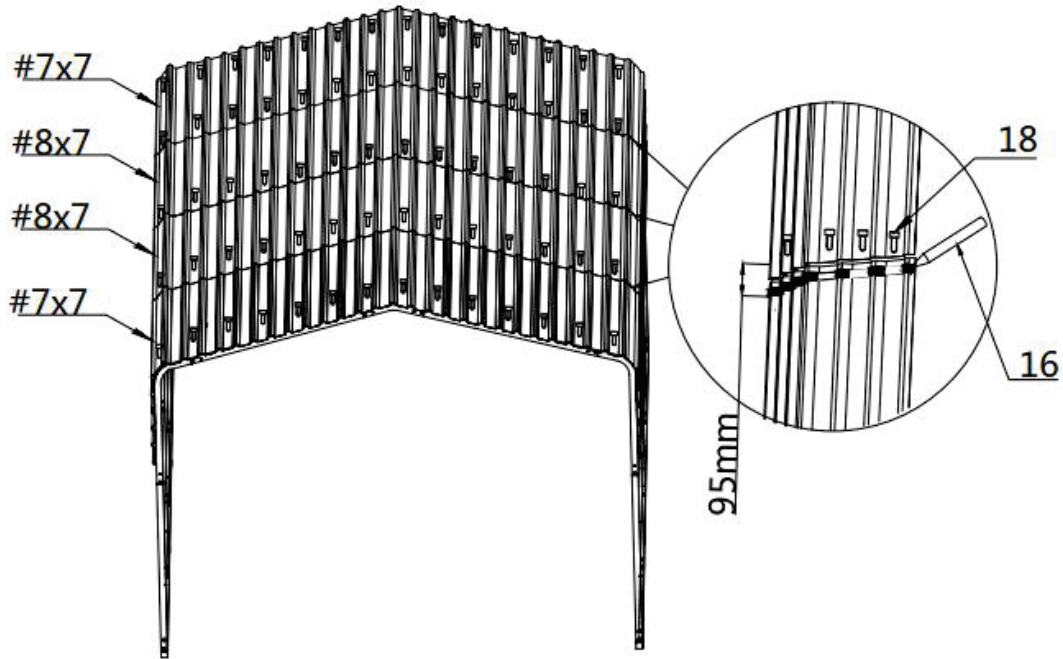

No.	Part	Qty
7		6
18		24

- Install all color iron tiles in turn, make sure that both ends of each color iron tile are aligned, and apply waterproof silicon sealant (#16) on the butt joint of both ends .





No.	Part	Qty
7		6
8		12

No.	Part	Qty
16		1
18		96

Step 5 : Install the front and rear edging strips.

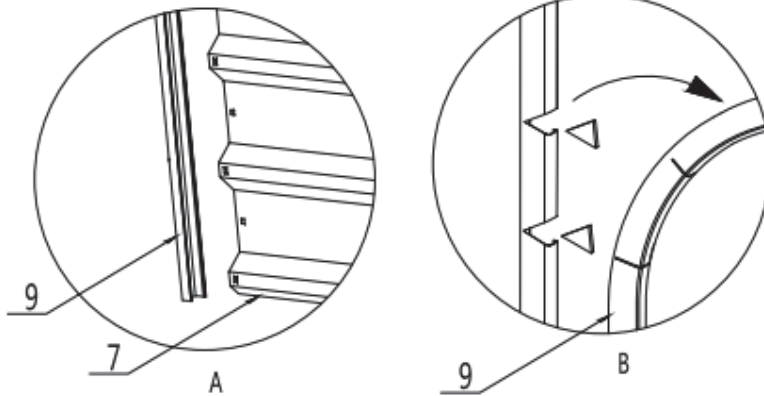
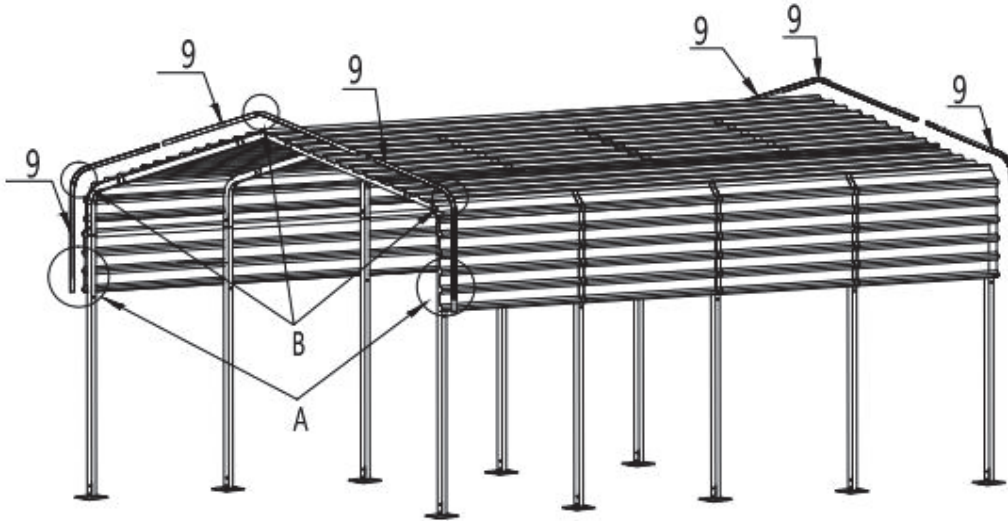
- Start to install the color iron tile edge protector (#9) from one side, and align one end with the color iron tile edge. The opening of the edge banding strip of the color iron tile shall be aligned with the end face of the color iron tile, and the bottom buckle can be pressed into place. It is necessary to use tools to cut out the gap at the corner so that the edge banding strip of color iron tile can be bent and installed .



No.	Part	Qty
9		6

- Install the edge buckle (#10), and the two raised card points of the Edge buckle are aligned with the square holes at the interfaces of the two color iron tile edge bands, and then press the buckle in place. The front and rear installation methods are the same.

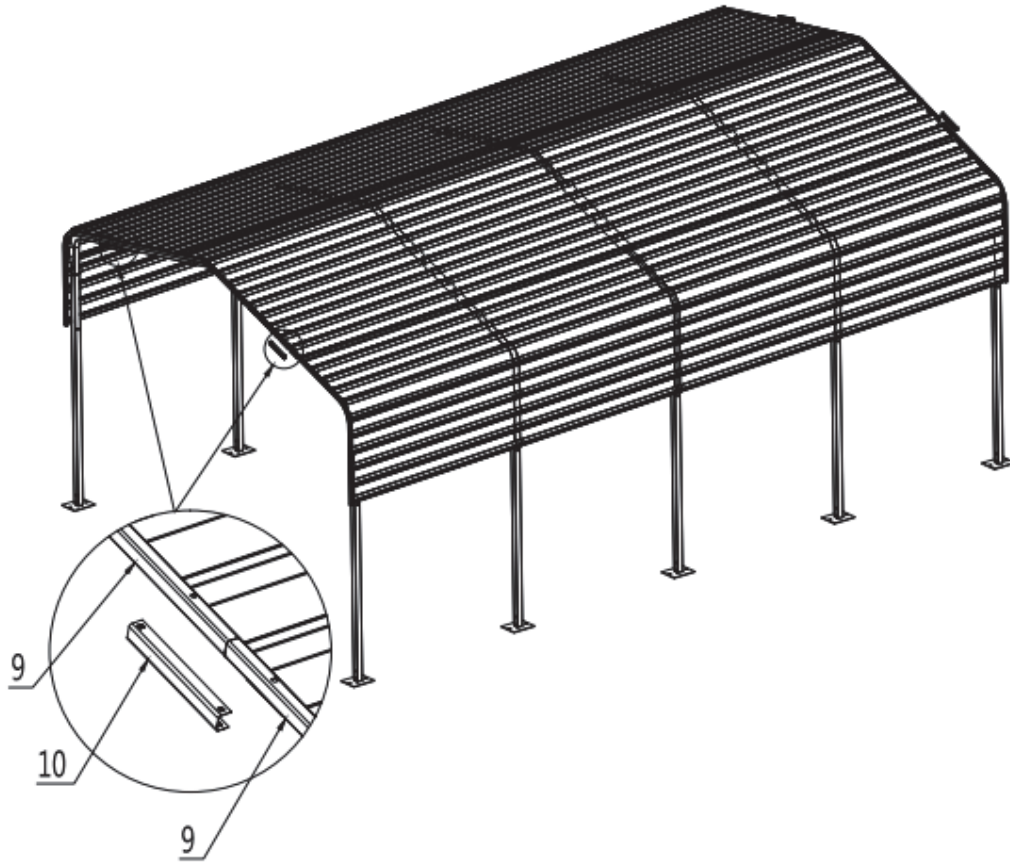



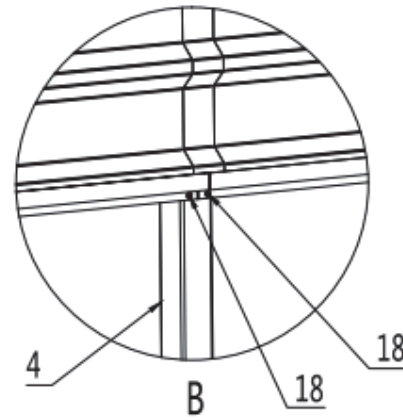
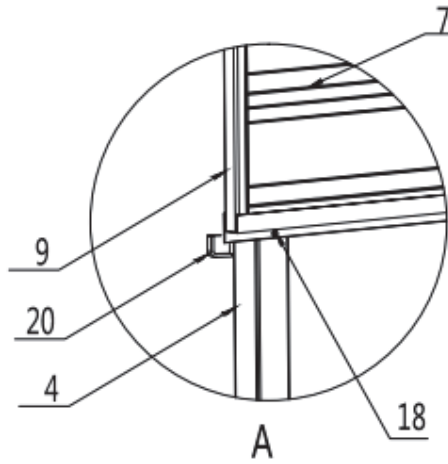
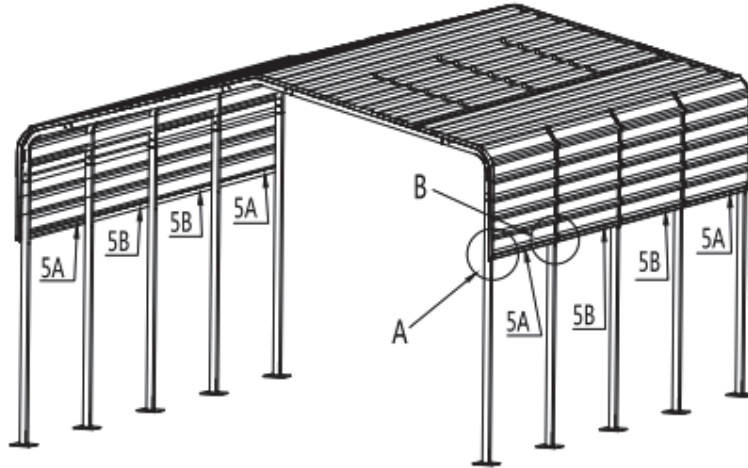

No.	Part	Qty
10		4

Step 6 : Connect the crossbar.

- Install the side connecting crossbar, align (#5A) side edge crossbar with the binding strip, wrap the colored steel tile binding strip and the colored steel tile inside the opening of the connect the crossbar, and fix them on the (# 4) Sidewall tube with (#18) self tapping screw. The installation method is the same on both sides.





No.	Part	Qty
5A		4
5B		4

No.	Part	Qty
18		16
20		4

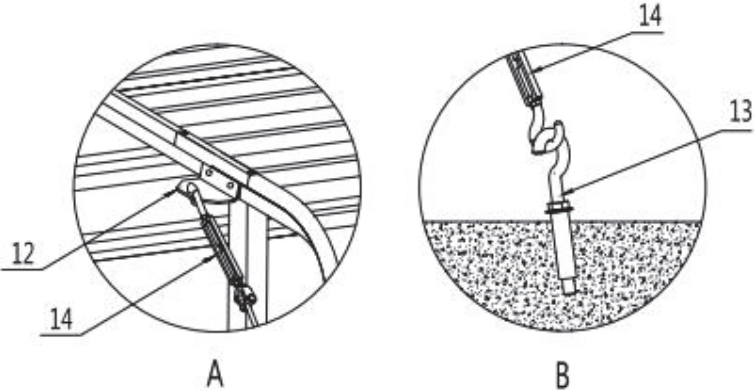
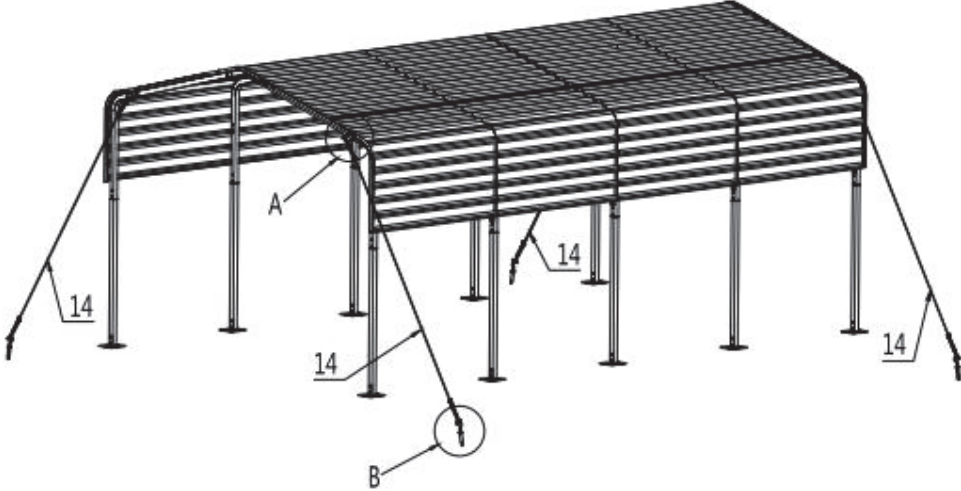
Step 7 : Install the wire rope.



No.	Part	Qty
13		4
14		4

Now that your building is completely installed, we need to check all components and trusses to make sure the whole structure is rectangular. Check whether the connection of color steel tile fits. We provide (#19) rivets, which can be used to fix the color steel tiles where necessary, so that they can fit together to prevent water leakage.

All bolts installed in this step can now be tightened. Do not over tighten the bolts, otherwise the pipes or components will be damaged.

After the Installation

Walk around and inspect the shelter periodically to make sure all components are still firmly secured and the whole shelter is well supported. Check all bolts and nuts as well as all connection points to make sure they are all in good position. Check the base plates, adjust the ropes and tie downs if required and clean the cover regularly.

Snow accumulating on the fabric cover must be removed as soon as possible. If snow becomes solid ice on the cover, it will increase the weight on the roof and may collapse the shelter or reduce the life span.

We strongly recommend you remove any snow from the roof immediately. Do not leave any snow load on the roof overnight. Keep 3 feet of clearance on all sides at all times. Do not allow snow to accumulate and pile up on the sides of the building. Otherwise the pressure from the sides will push inwards and could lead to a collapse.

ATTENTION

TO ENSURE THAT YOUR CARPORT SHED HAS BEEN SECURELY INSTALLED AND ITS WARRANTY VALIDITY, IT IS IMPORTANT TO READ THE FOLLOWING PAGES CAREFULLY.

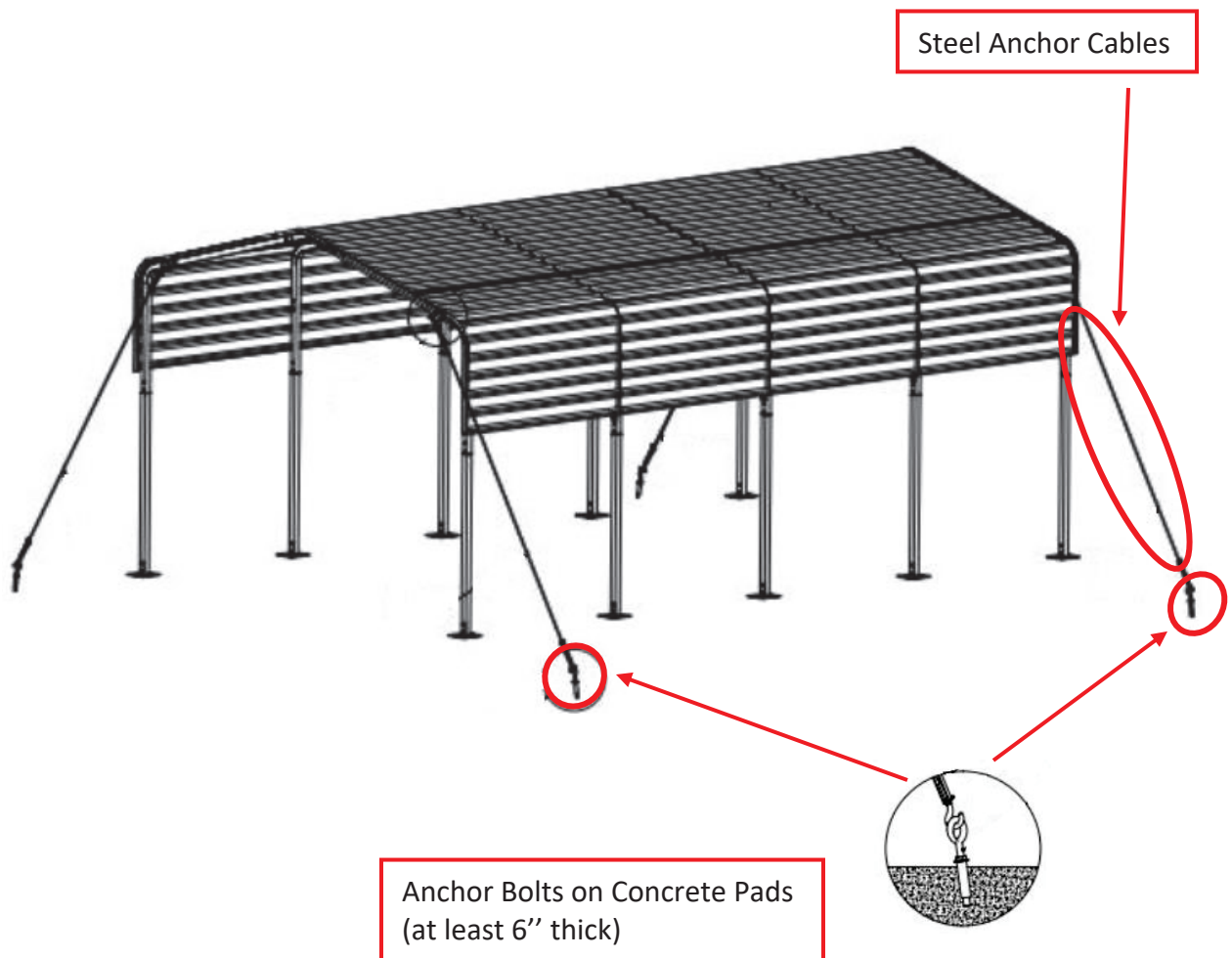

As the owner of your product, it is important to take the necessary steps to ensure its stability and durability, especially in areas where heavy snow or high winds are common. Following these two steps will help prevent any damage due to snow or wind loads, and ensure that the product warranty remains valid.

1. Steel Anchor Cables

Steel anchor cables are a critical component of the shed's stability, as they hold the shed firmly to the ground and prevent it from being lifted or shifted by wind or snow loads. These cables should be installed on **all four corners** of the shed and attached to the ground using suitable anchors. It is important to ensure that the cables are securely anchored to the ground, as any loosening could compromise the shed's stability.

2. Concrete Pad and Anchor Bolts

Installing the shed on a concrete pad or equivalent provides a stable foundation for the shed and helps to prevent it from shifting or settling over time. Anchor bolts should be used to secure the shed firmly to the concrete pad, ensuring that it does not move during high winds or heavy snow loads. It is important to ensure that the anchor bolts are installed according to the manufacturer's instructions and that they are tightened securely.

It is important to note that the shed is not engineered to handle snow and wind loads, and the engineering drawing is not available from the seller. Therefore, it is crucial to check the local building codes and regulations to determine if a permit is required for the installation of the shed. In some areas, a permit may be required for any type of structure, regardless of whether it is engineered to handle snow and wind loads.

If a permit is required and the shed does not meet the engineering requirements, it may not be possible to obtain a permit for its installation. In such cases, it may be necessary to either modify the shed to meet the engineering requirements or to choose a different type of structure that is designed to handle snow and wind loads. Any modifications required to meet building codes and regulations are the sole responsibility and expense of the owner.

In summary, it is important to prioritize safety and compliance with local building codes and regulations to avoid any potential safety hazards or legal issues in the future. By following these three steps, you can ensure the stability and durability of your shed and prevent any damage due to snow or wind loads. Remember, failure to follow these steps may result in the voiding of the product warranty.