

# INSTALLATION INSTRUCTIONS

--TMG1220

[WWW.TMGINDUSTRIAL.COM](http://WWW.TMGINDUSTRIAL.COM)

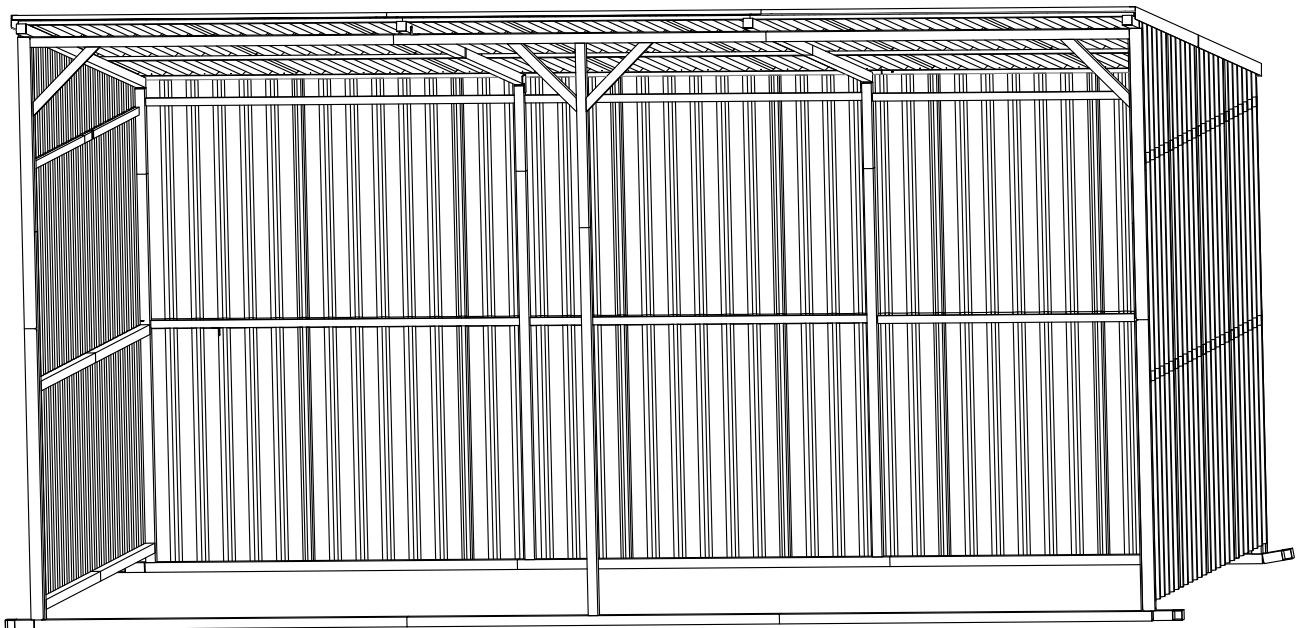





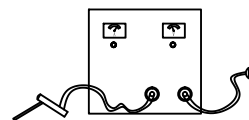
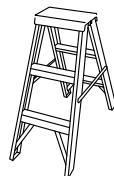
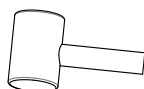
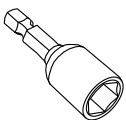
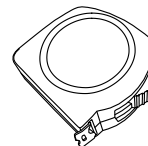
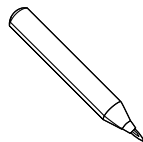
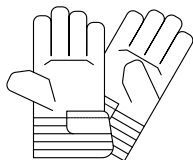

### INSTALLATION TIPS:

1. Please read the instruction for use carefully before starting installation.
2. All the installation must be done by adult, when installing, please keep the children away from it.
3. When installing, please use the gloves to avoid injured yourself.
4. Please find out whether approval of local government council is required for the shed before you start assembly. It will make it much easier if you thoroughly go through this booklet before starting installation.
5. All the unit of measurement is millimeter.
6. Use J1 to connect two U-section channels.
7. The product needs to be welded, please pay attention to electricity safety during use.
8. Product specifications may change without notice.

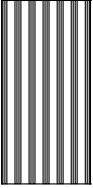
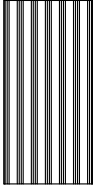
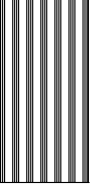
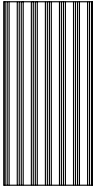
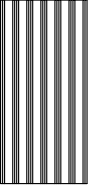
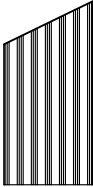
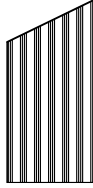
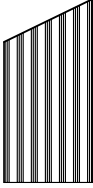
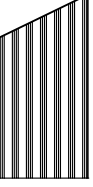
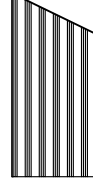
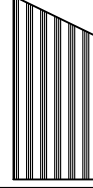
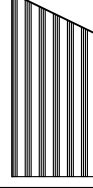
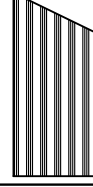





















### TOOLS REQUIRED:



# PART LIST

picture	Name	QTY	Check	picture	Name	QTY	Check
	P1300A	7			P1300B	7	
	P1175	16			P1260A	14	
	P1260B	7			P780A	1	
	P630A	1			P490A	1	
	P345A	1			P780B	1	
	P630B	1			P490B	1	
	P345B	1					
	A1940	9			A1620	8	
	A1998	7			A950	3	
	A440	4			A1770	8	

# PART LIST

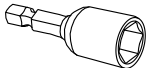
picture	Name	QTY	Check	picture	Name	QTY	Check
	A500	4			A100	4	
	A60	4			B1925	4	
	B1620	4			B1760	2	
	B2000	6			B1810	3	
	C200	8			F1950A	2	
	F1950	1			F1947A	2	
	LB1980	3			F1947	1	
	L1870	4			L1500	4	
	C13	6			C14	6	
	S12	560			C15	7	
	L5	12			J1	4	
		1					

# BEFORE WELDING

## Technical description:

1. It is recommended to adopt gas shielded arc welding and use 1.2 welding wire, grade ER50-6. Welding current: 180-220A, voltage: 18-20V;
2. It is recommended that spot welding be taken as a whole and then full welding of the connection points to ensure the structural strength of the livestock shed.
3. The above suggestions are for reference only, and the corresponding welding methods can be adopted according to the equipment in the field.

## STEP 1

The square pipe should be welded into the required parts according to the requirements of the following drawings, and the corresponding labels should be pasted.

For example, PART D, as shown in the diagram, first connect A1620 to C200 with S12, then weld it with another A1620, and identify it as PART D.

For example, PART F is directly welded by two A1620 and identified as PART F according to the diagram.

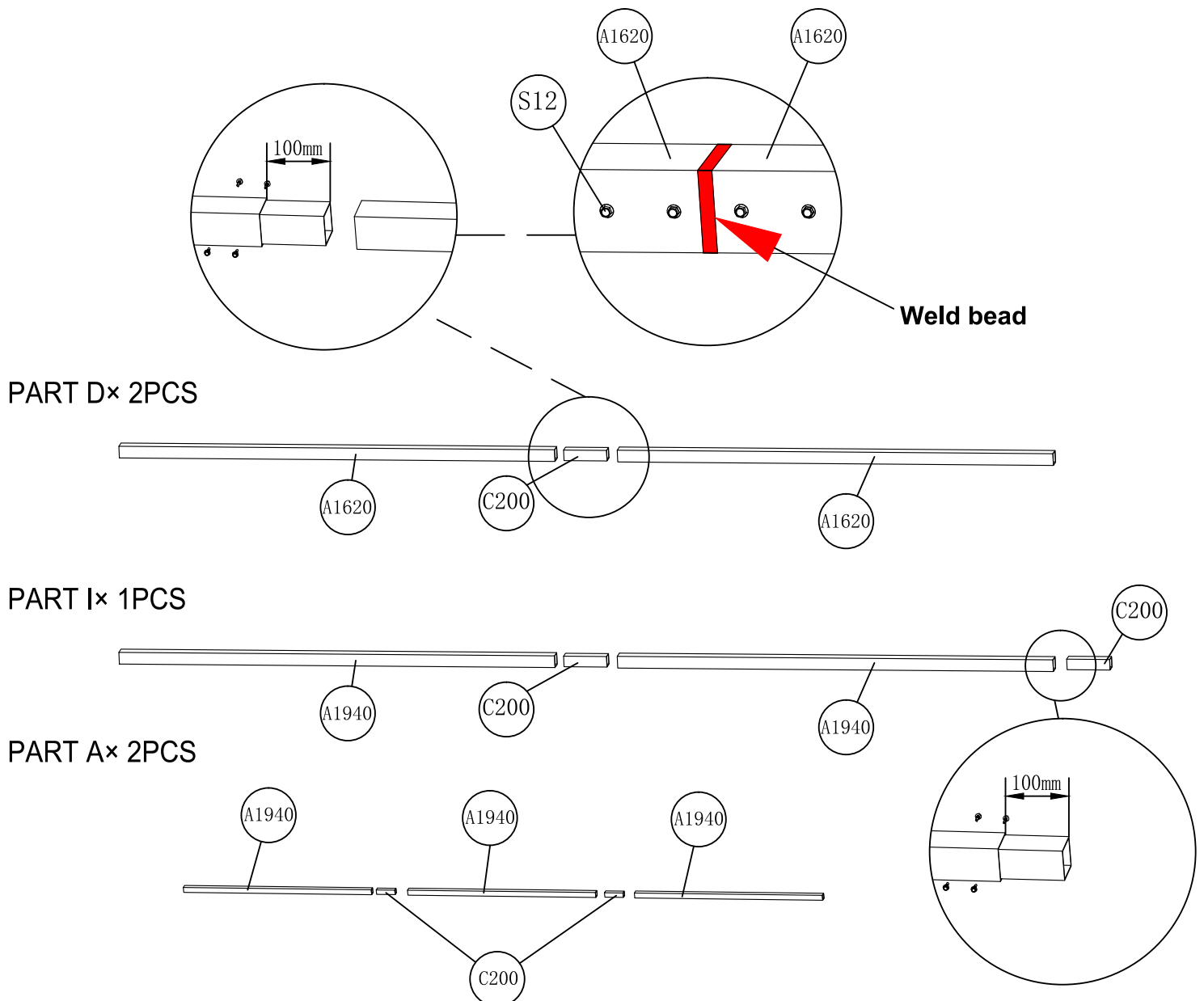

# PANEL ASSEMBLY

---

PART B × 4PCS

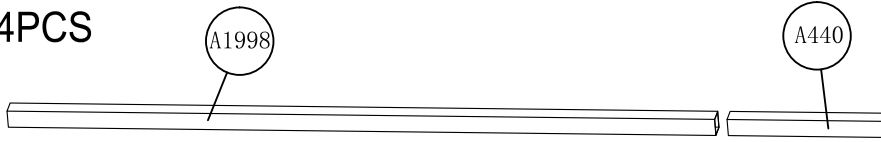

PART C × 3PCS

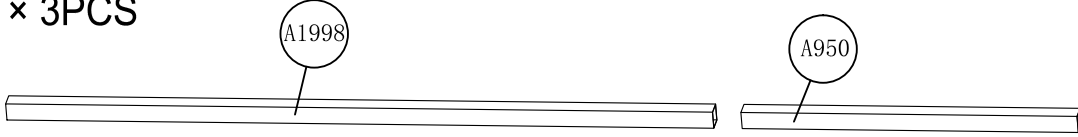

PART H × 4PCS

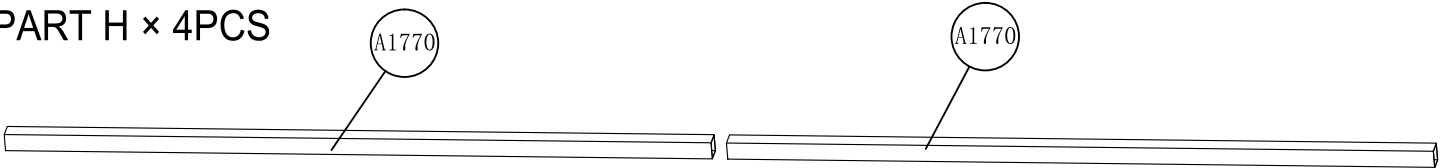

PART F × 2PCS

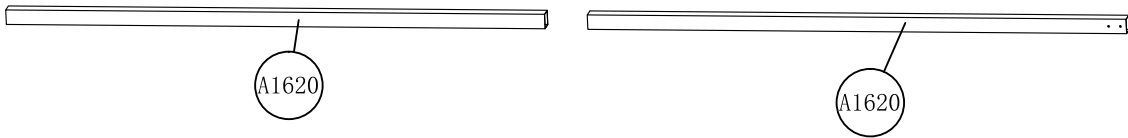

PART E × 2PCS



# FRAME ASSEMBLY

## STEP 2

Please select flat ground for assembly and place PART A.

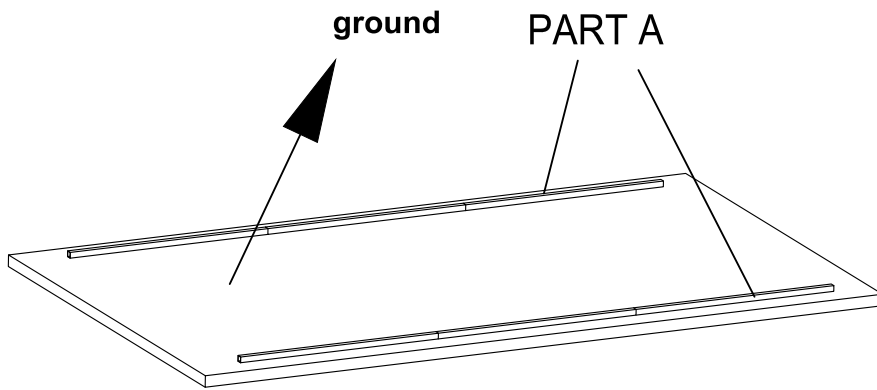

## STEP 3

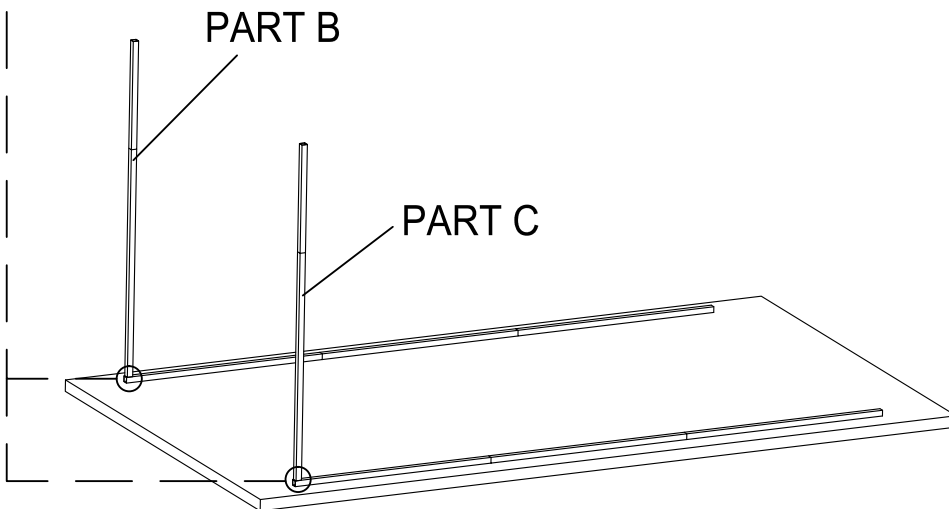
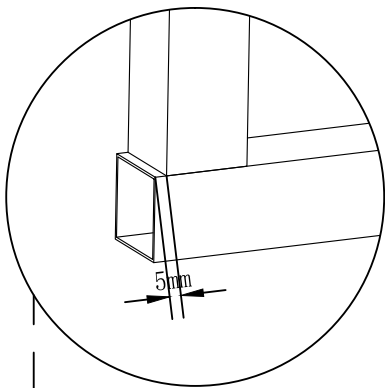

# FRAME ASSEMBLY

## STEP 4

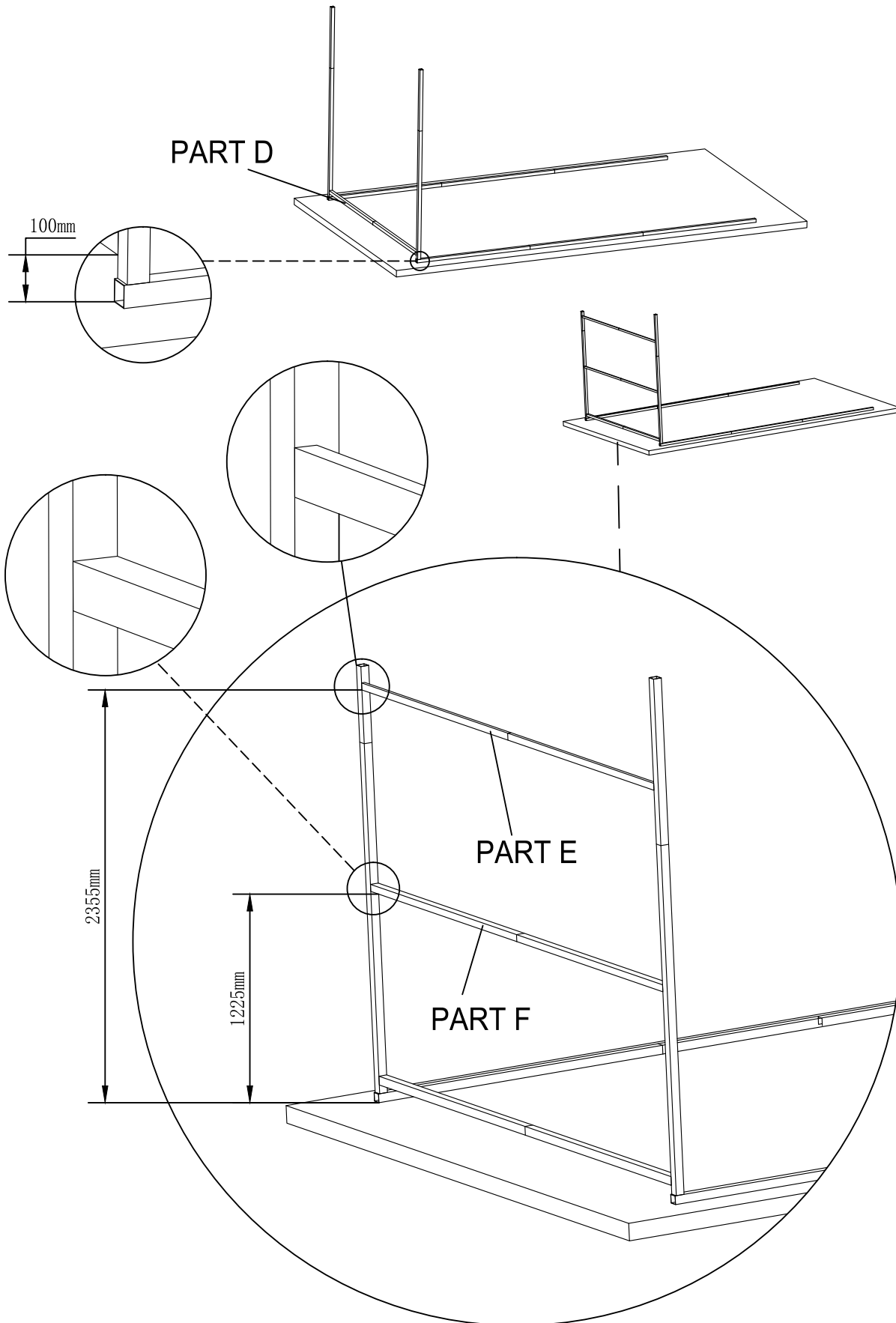



STEP 5

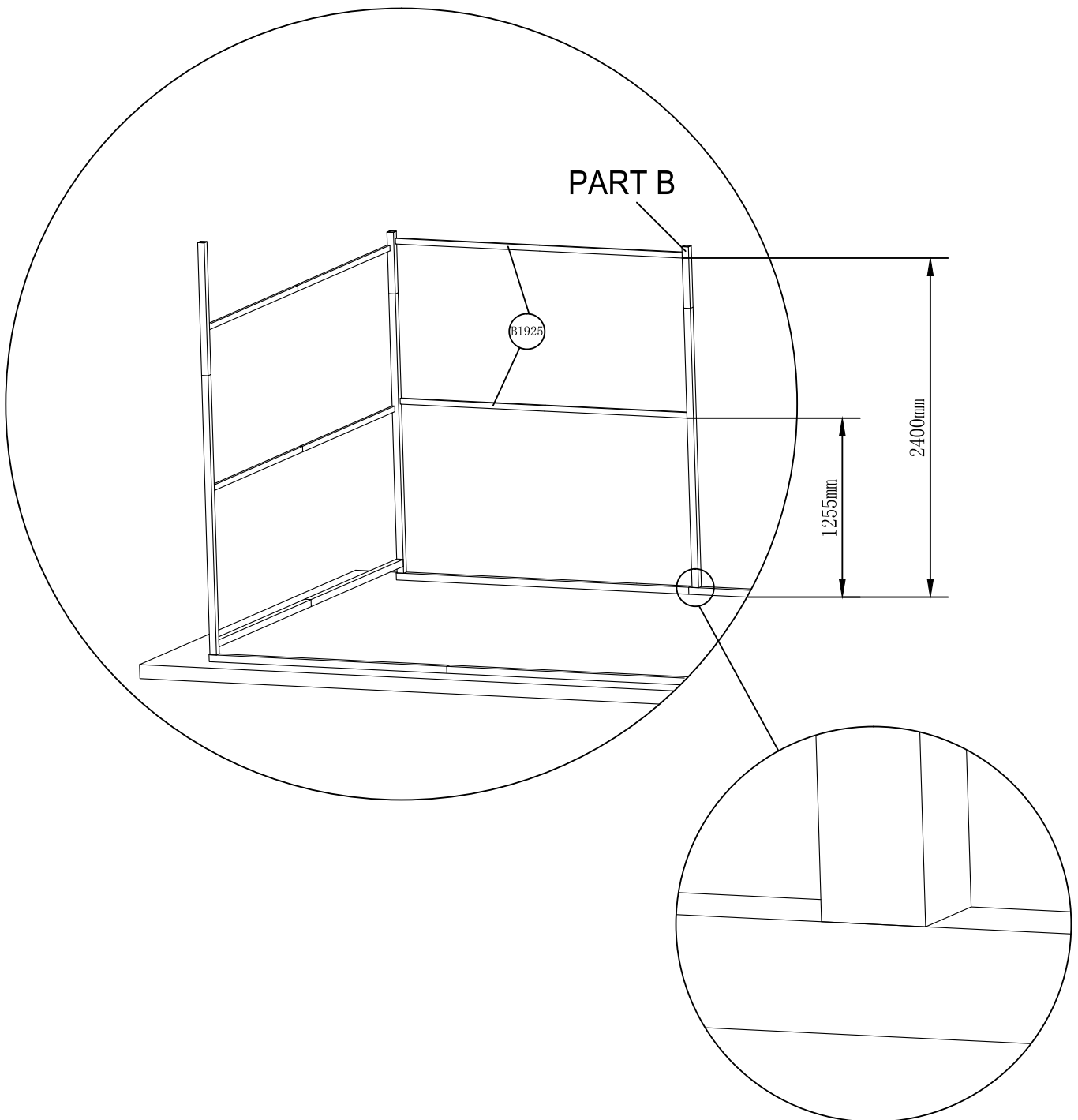
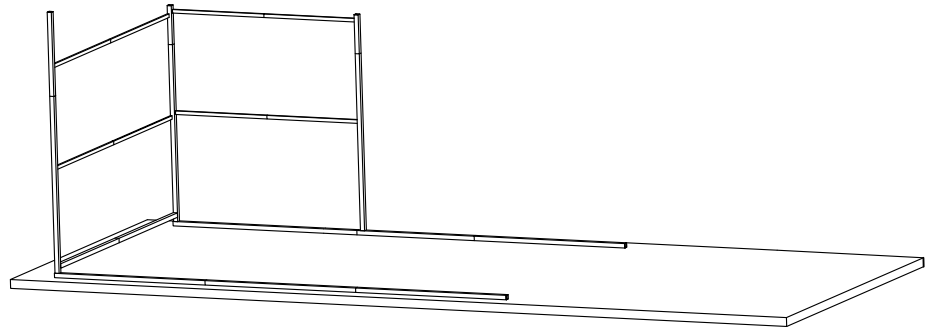

# FRAME ASSEMBLY

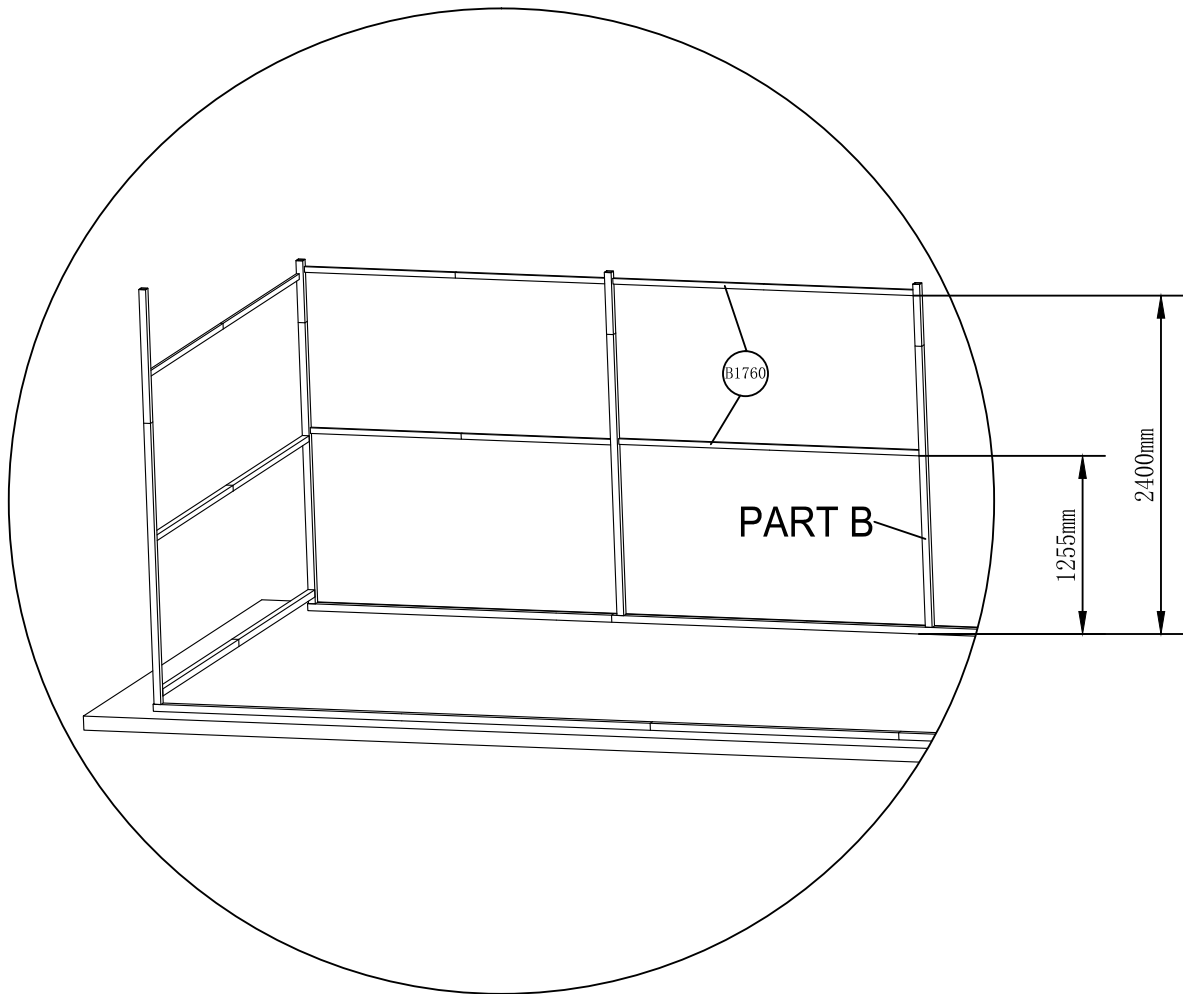
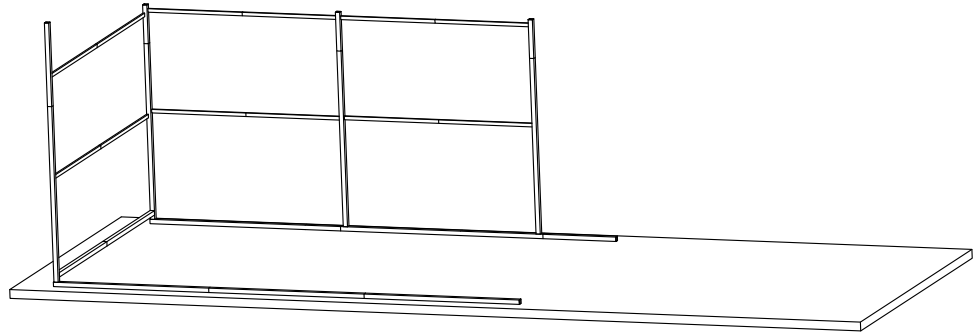

# FRAME ASSEMBLY

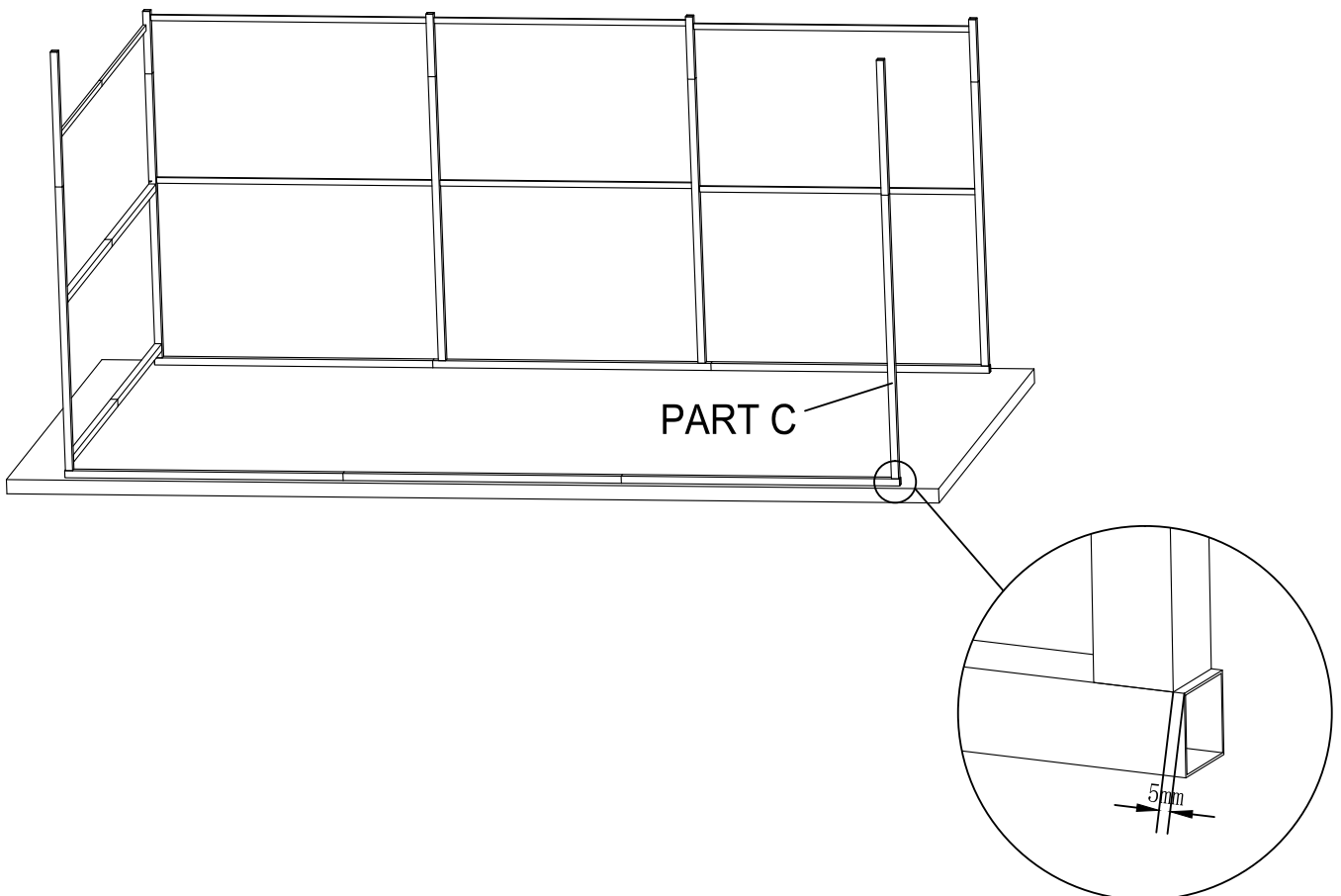
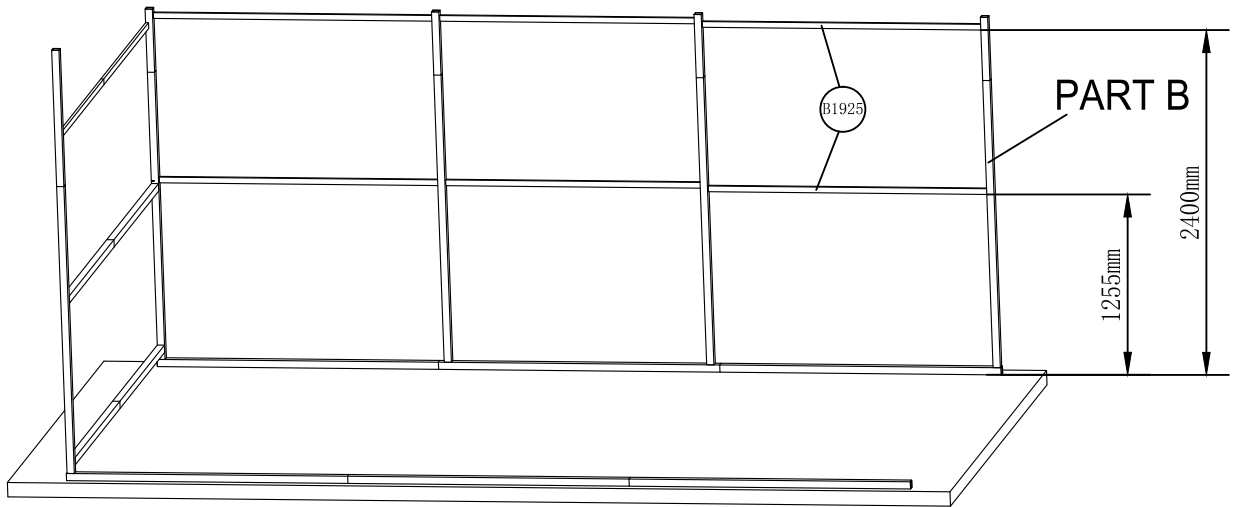

STEP 6

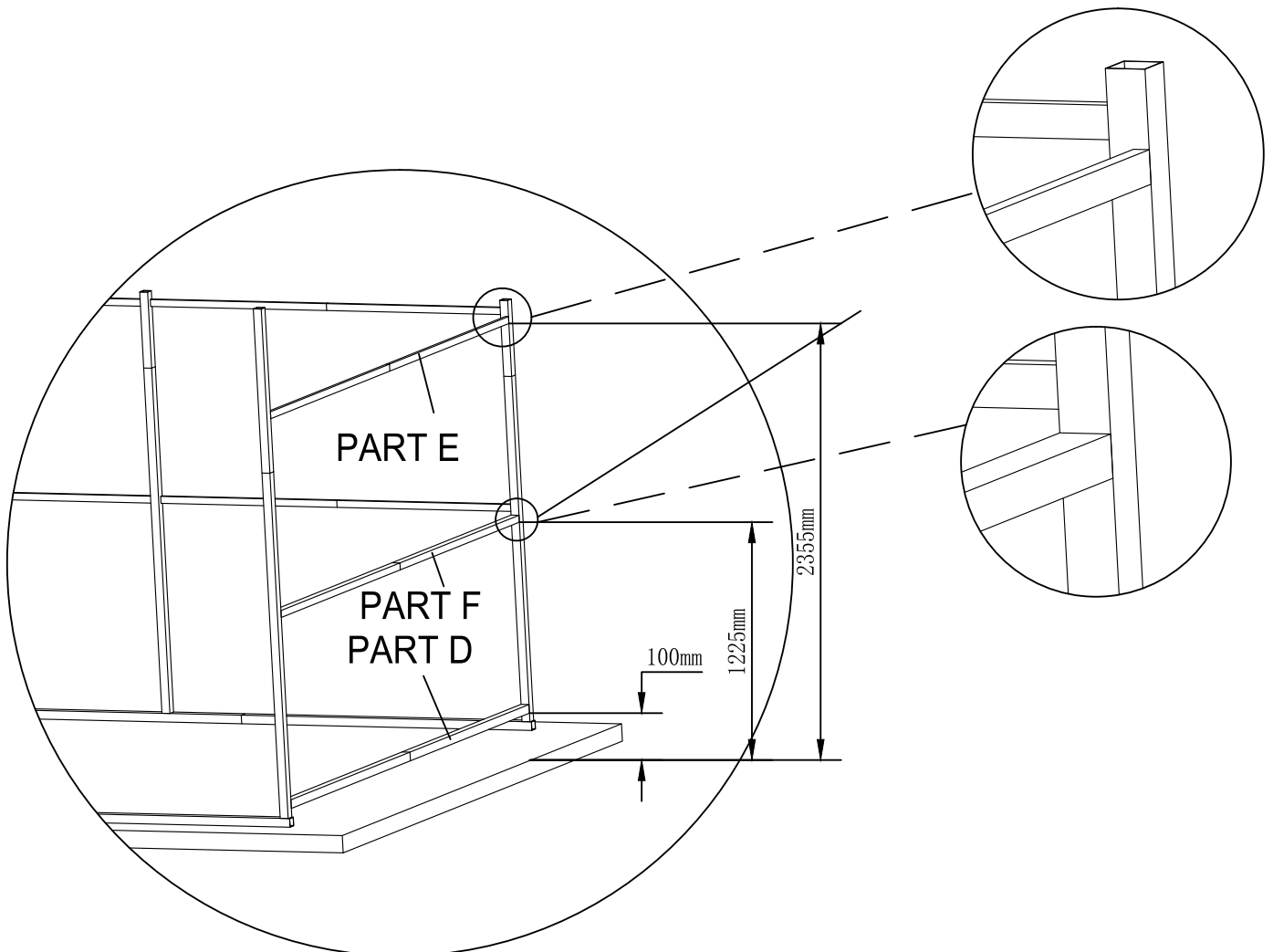
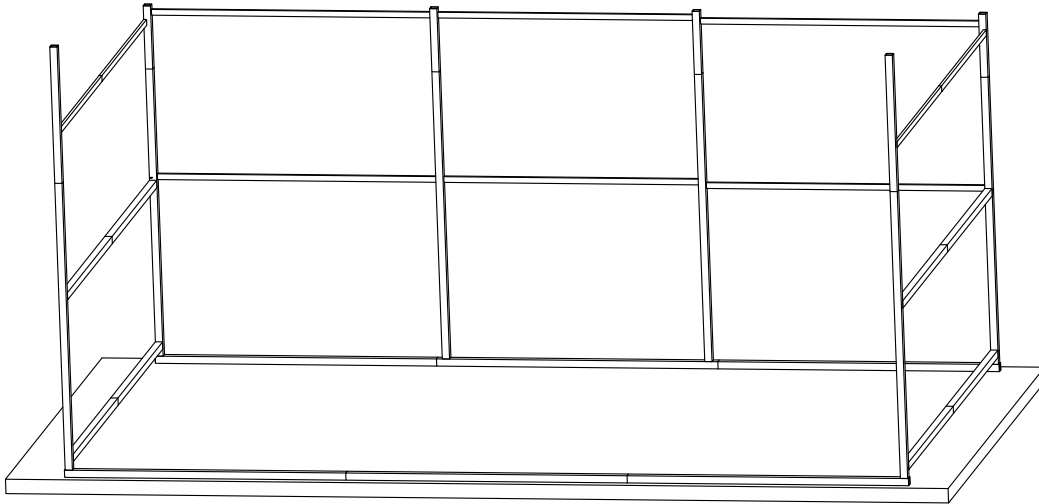

# FRAME ASSEMBLY

## STEP 7

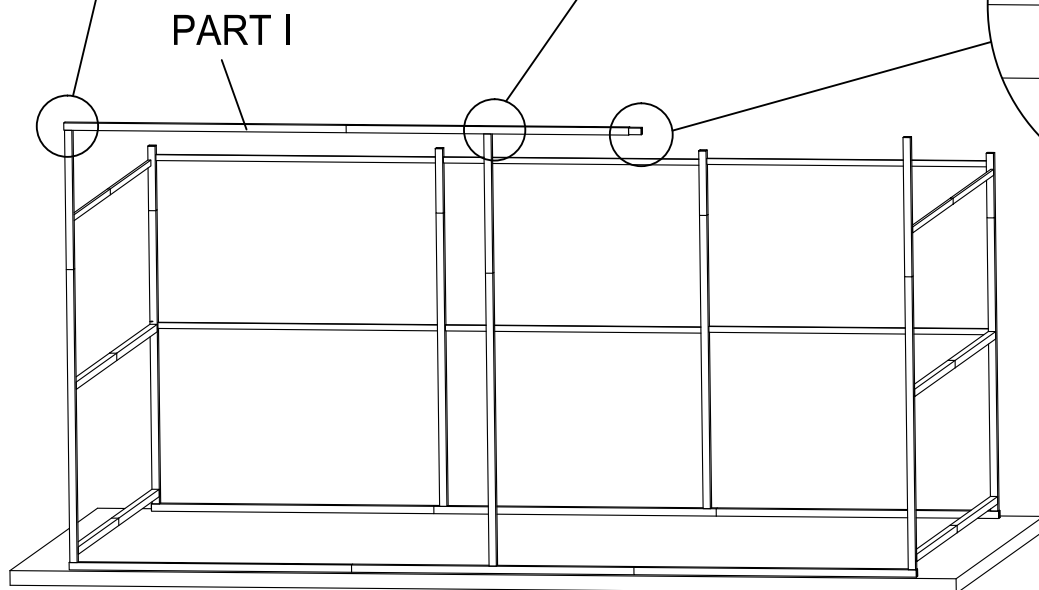
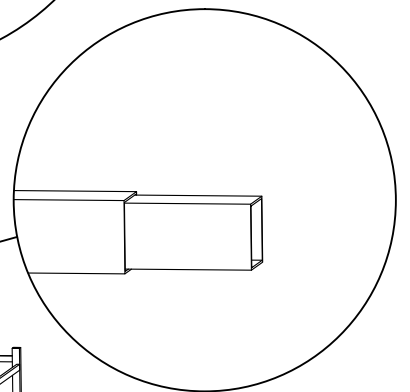
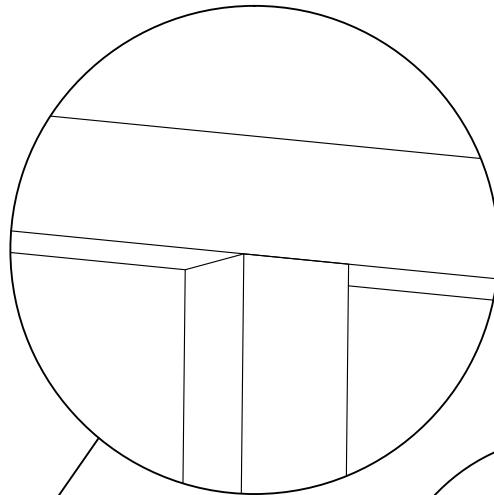
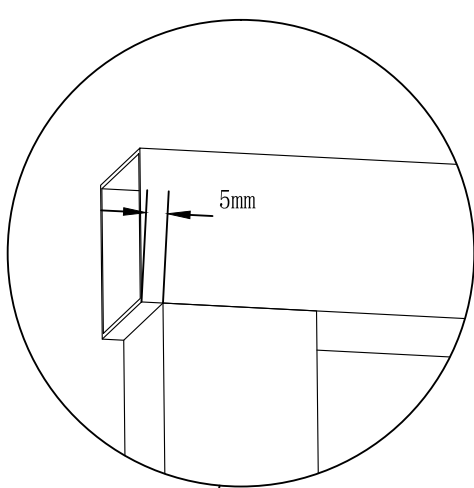
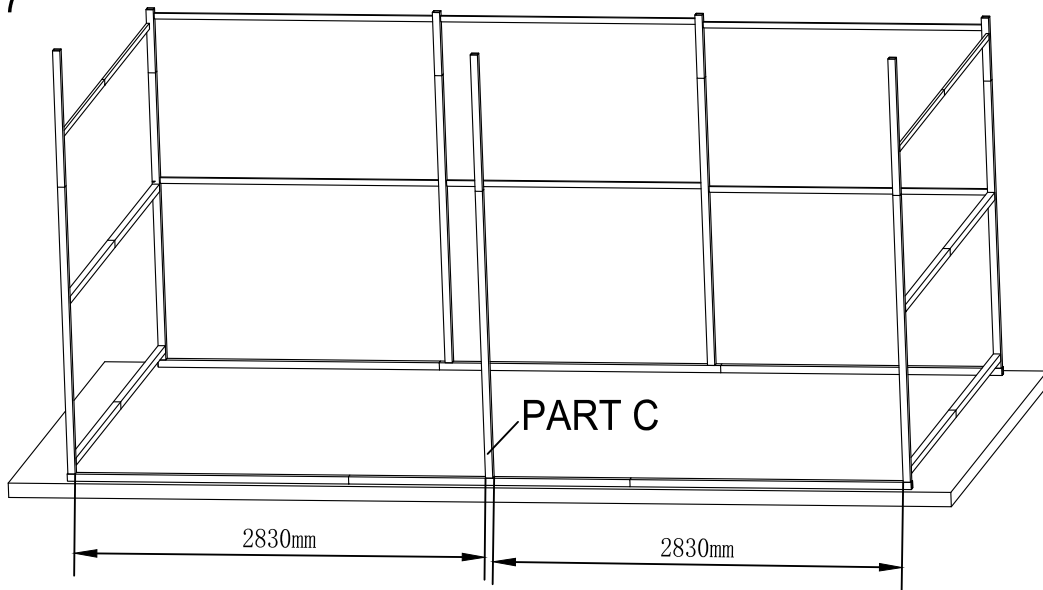

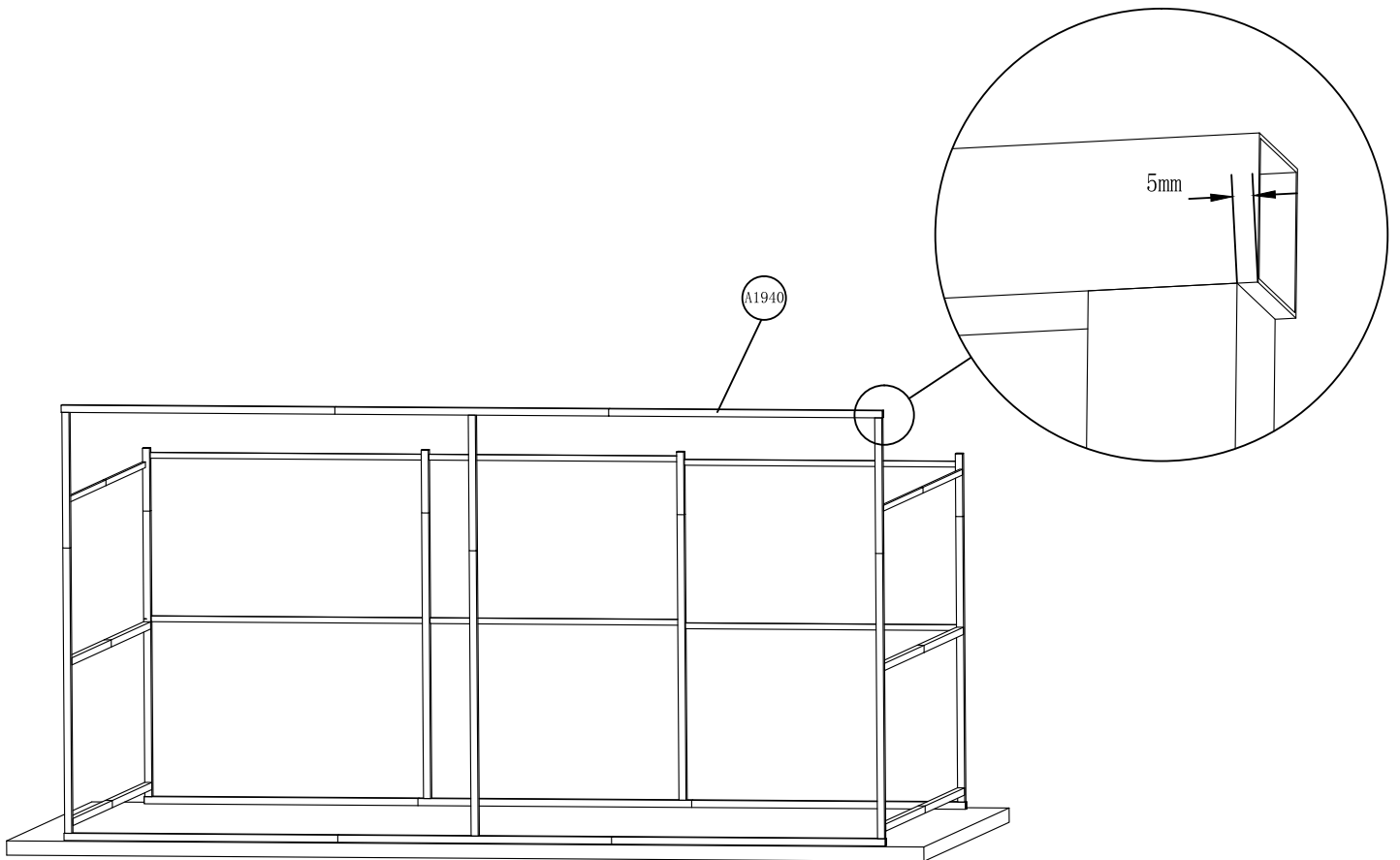

STEP 11

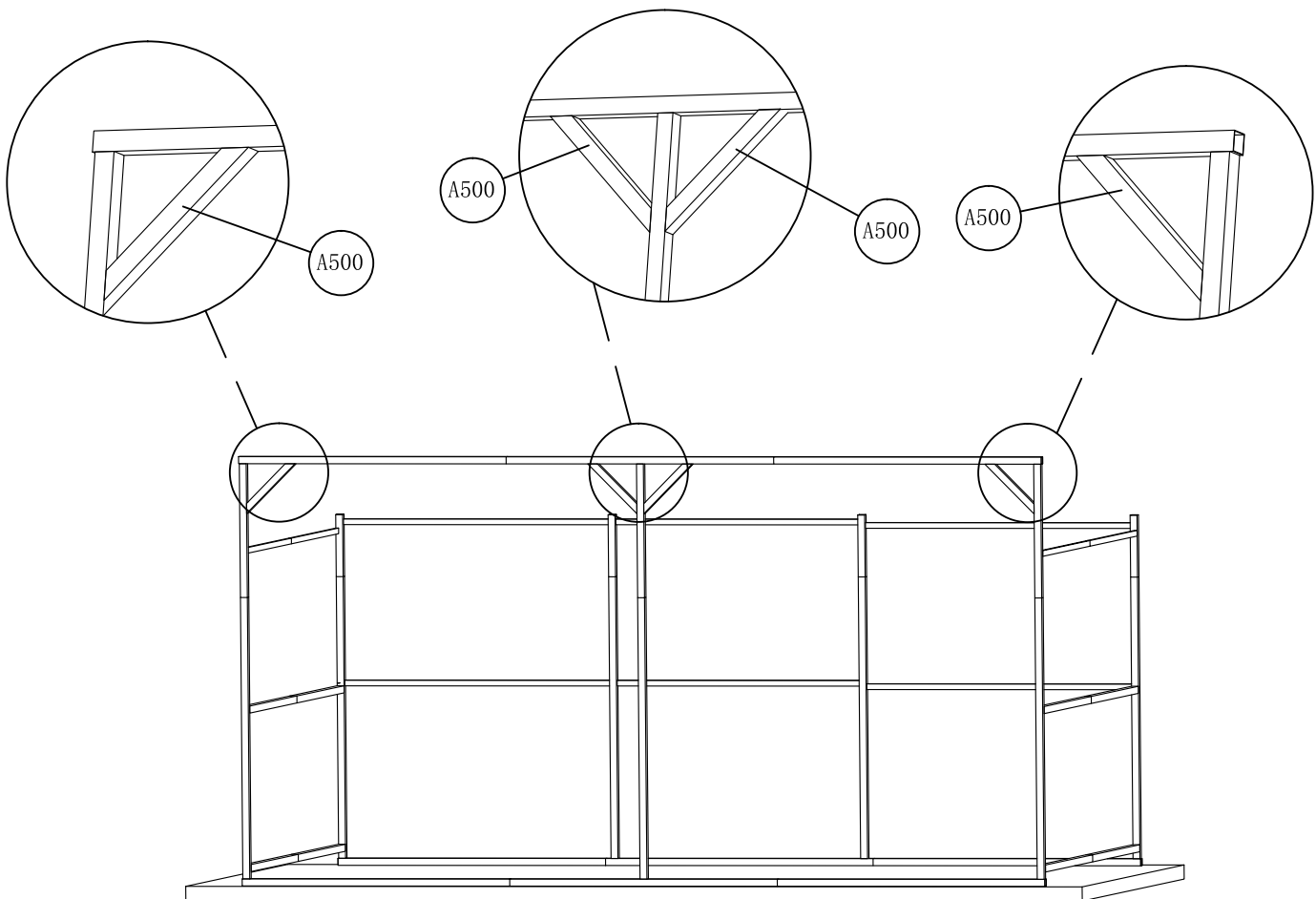

# FRAME ASSEMBLY

## STEP 8

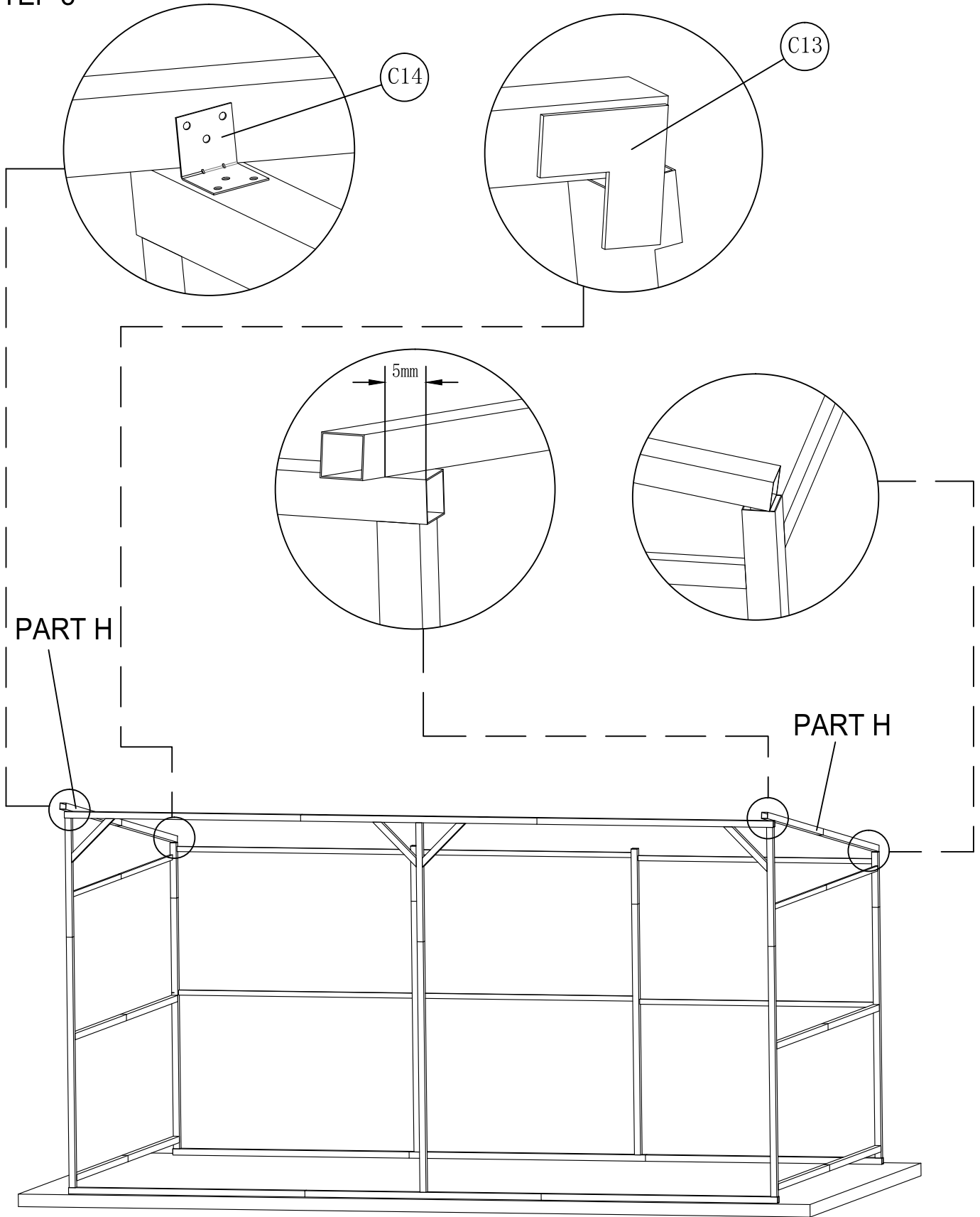

# FRAME ASSEMBLY

## STEP 9

Determine the location of the PART H using the length of the B2000

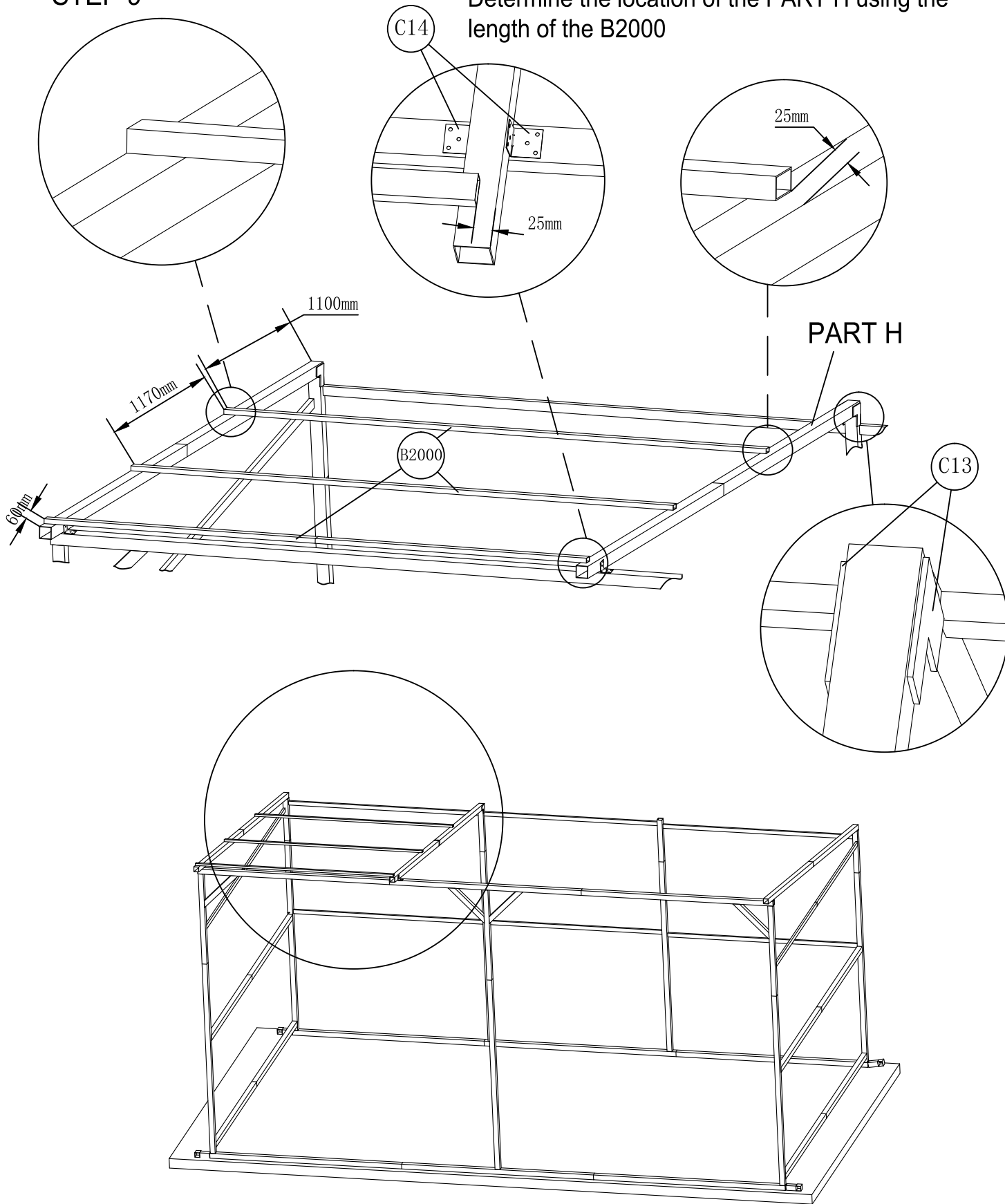



# FRAME ASSEMBLY

Determine the location of the PART H using the length of the B1810

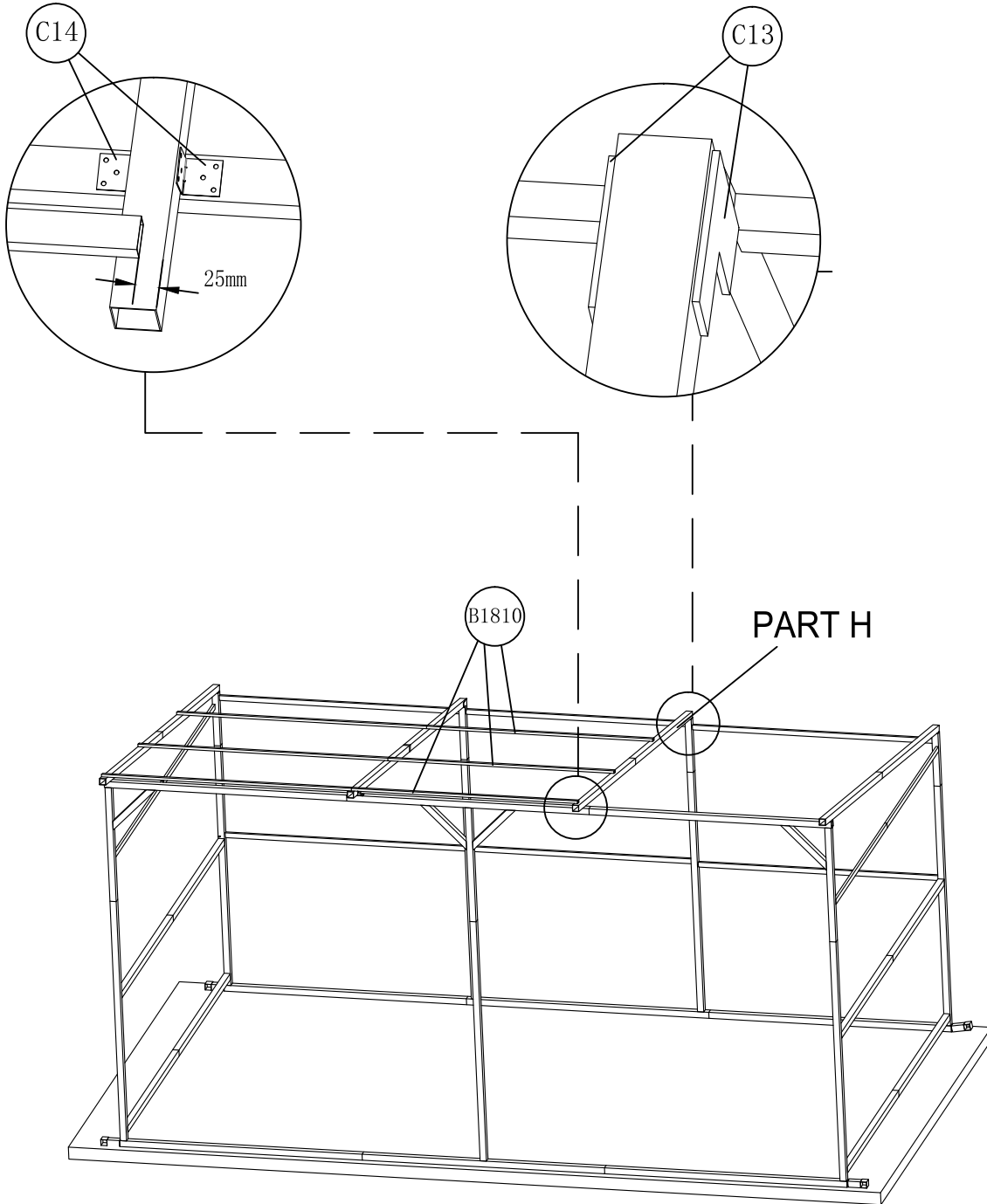

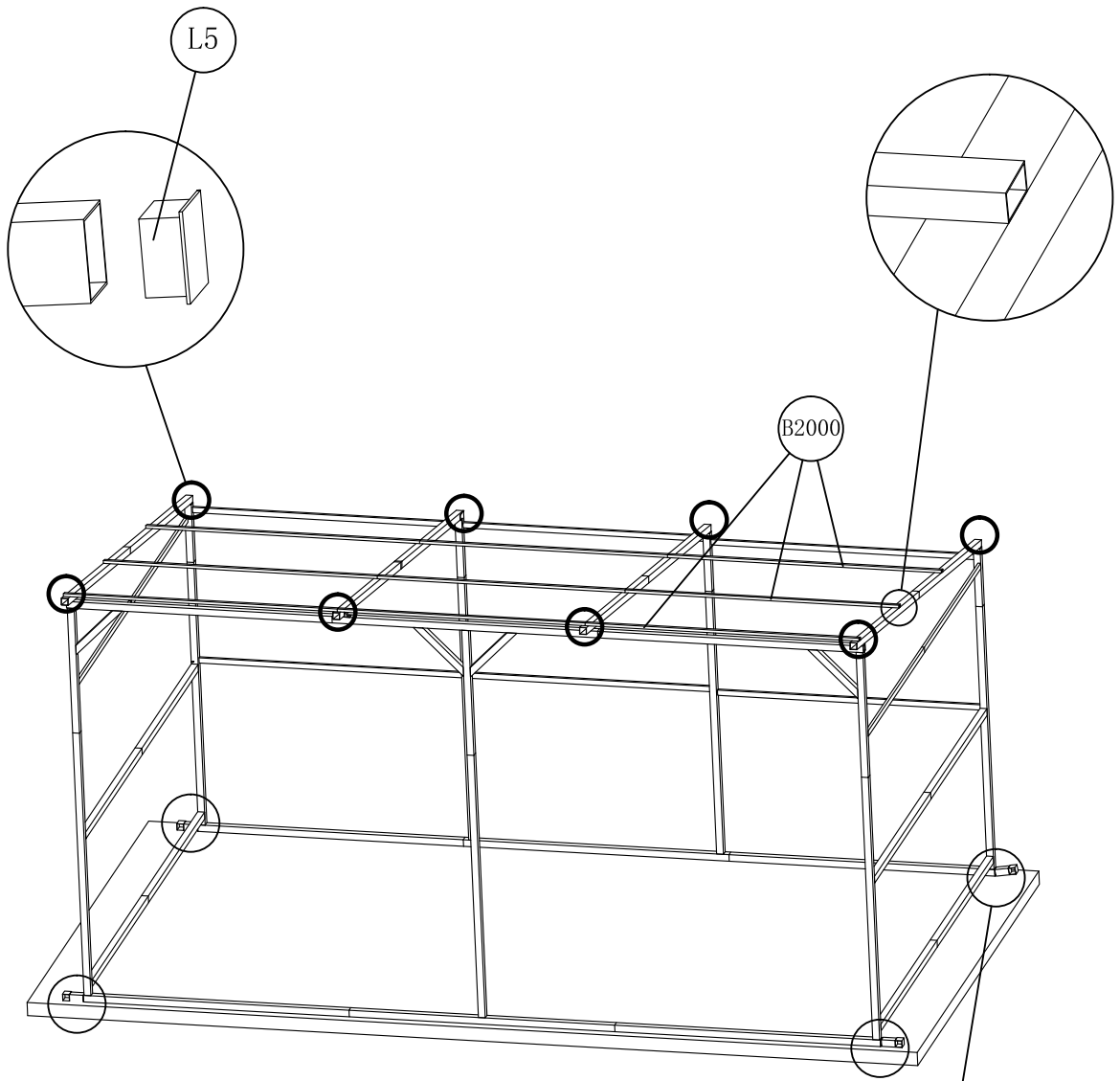

STEP 10

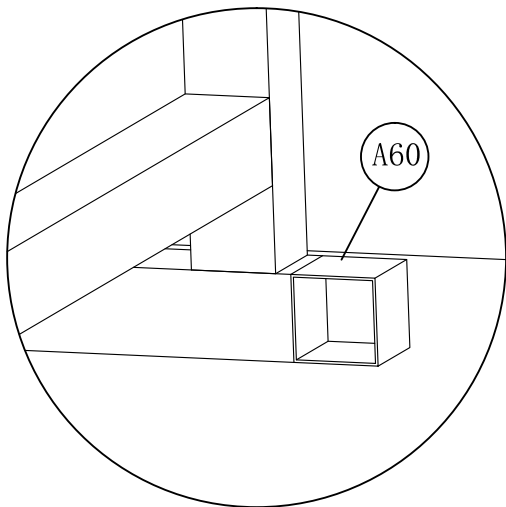

OR

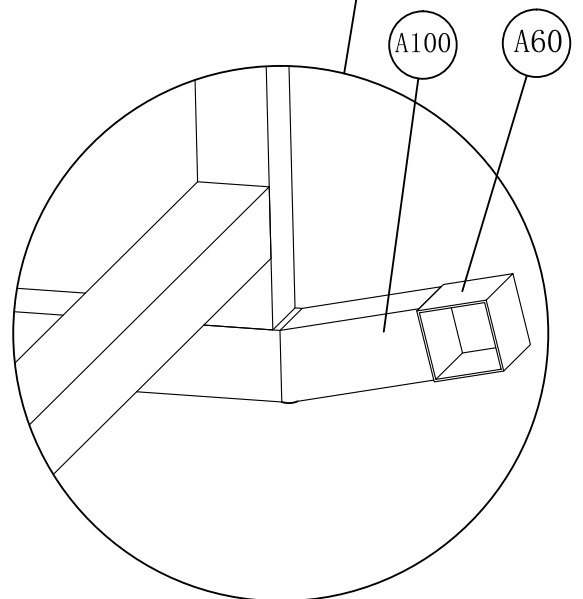

# PANEL ASSEMBLY

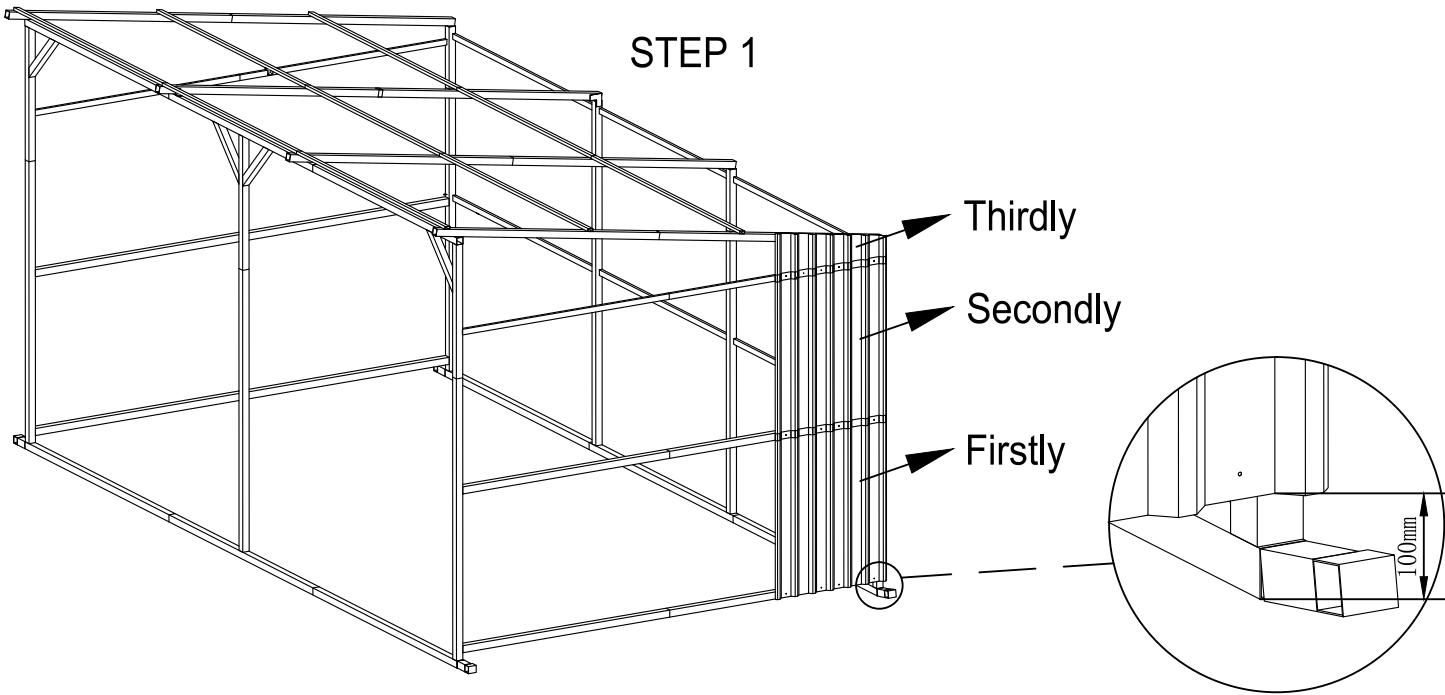

## STEP 1.1

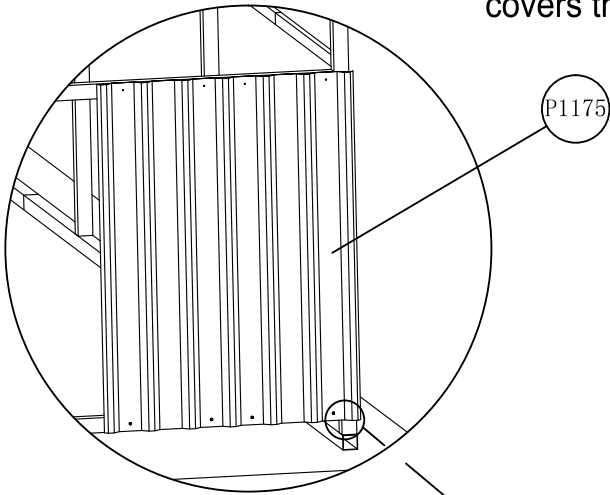

When two panels overlap, make sure upper panel covers the lower panel.

## STEP 1.2

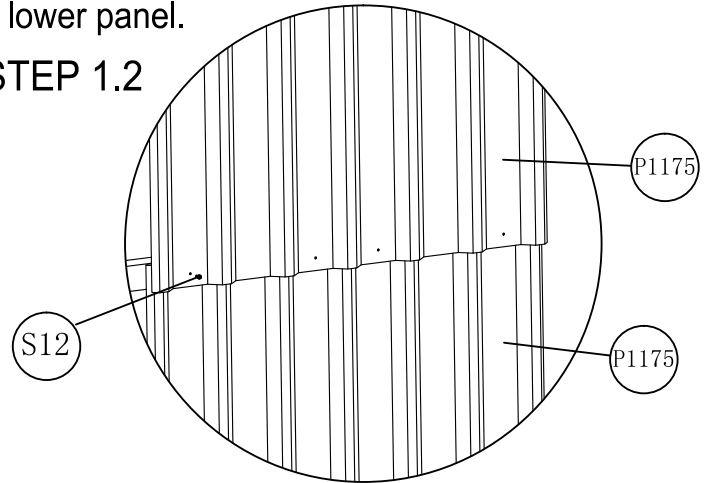

## STEP 1.3

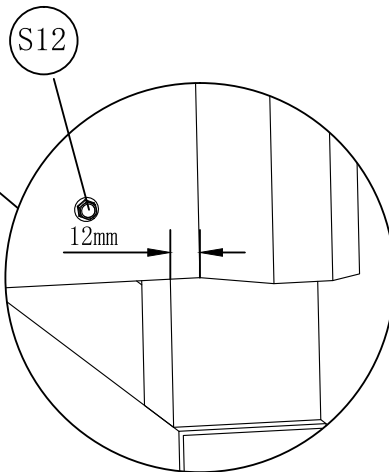
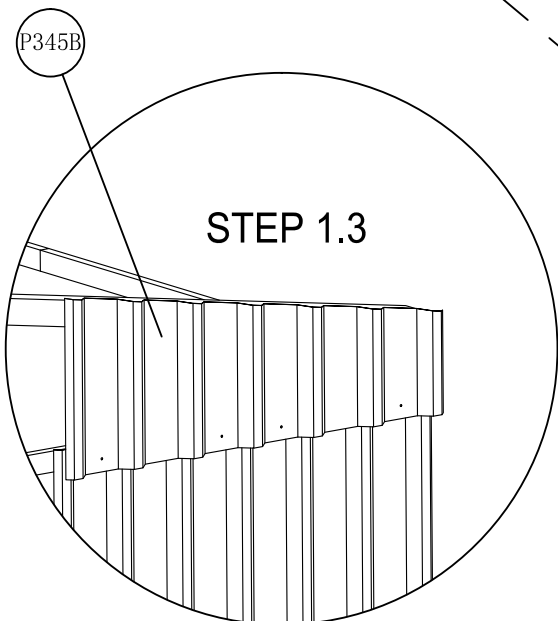

# PANEL ASSEMBLY

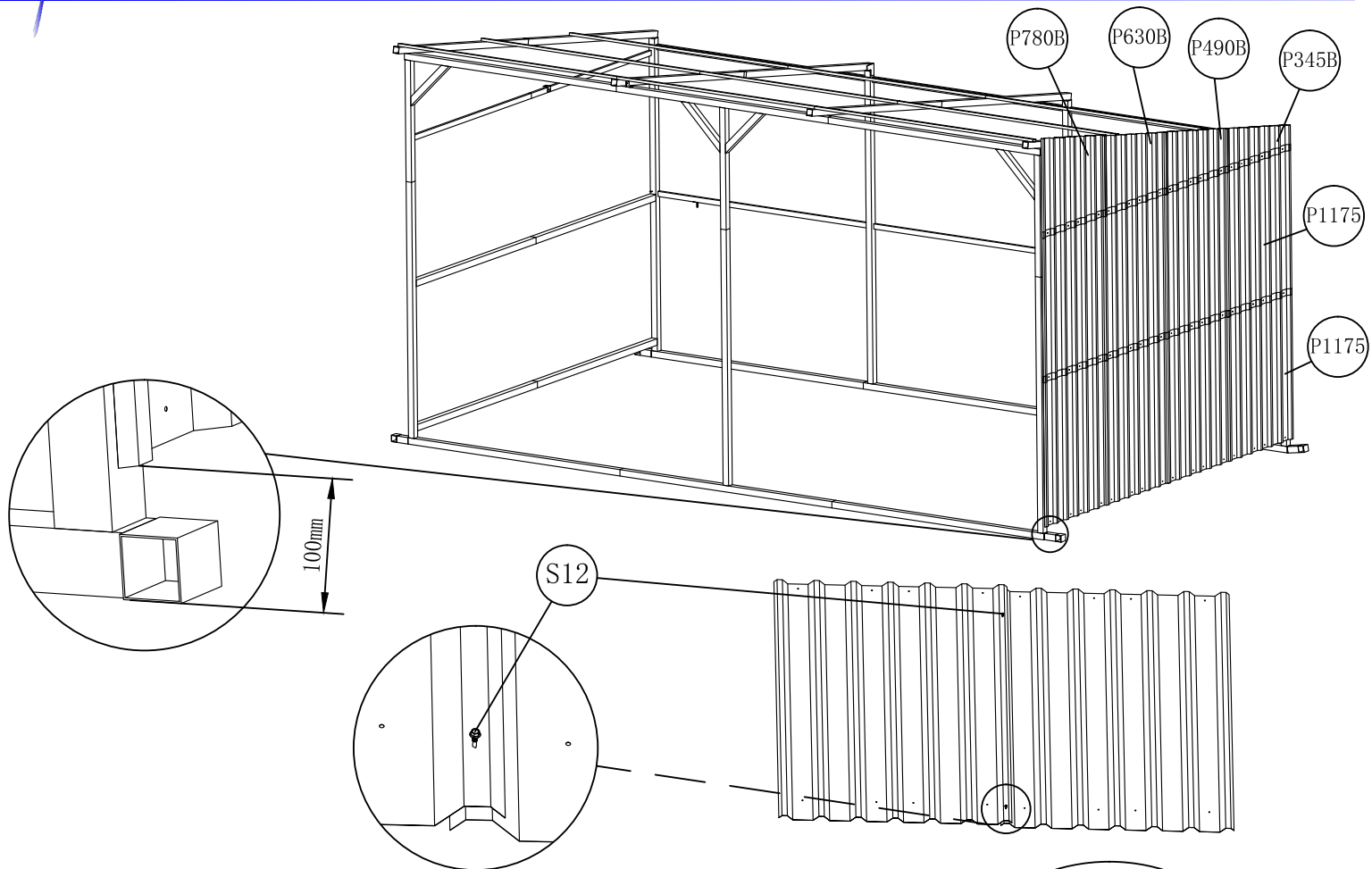

Two color steel plate overlaps with S12 connection

STEP 2

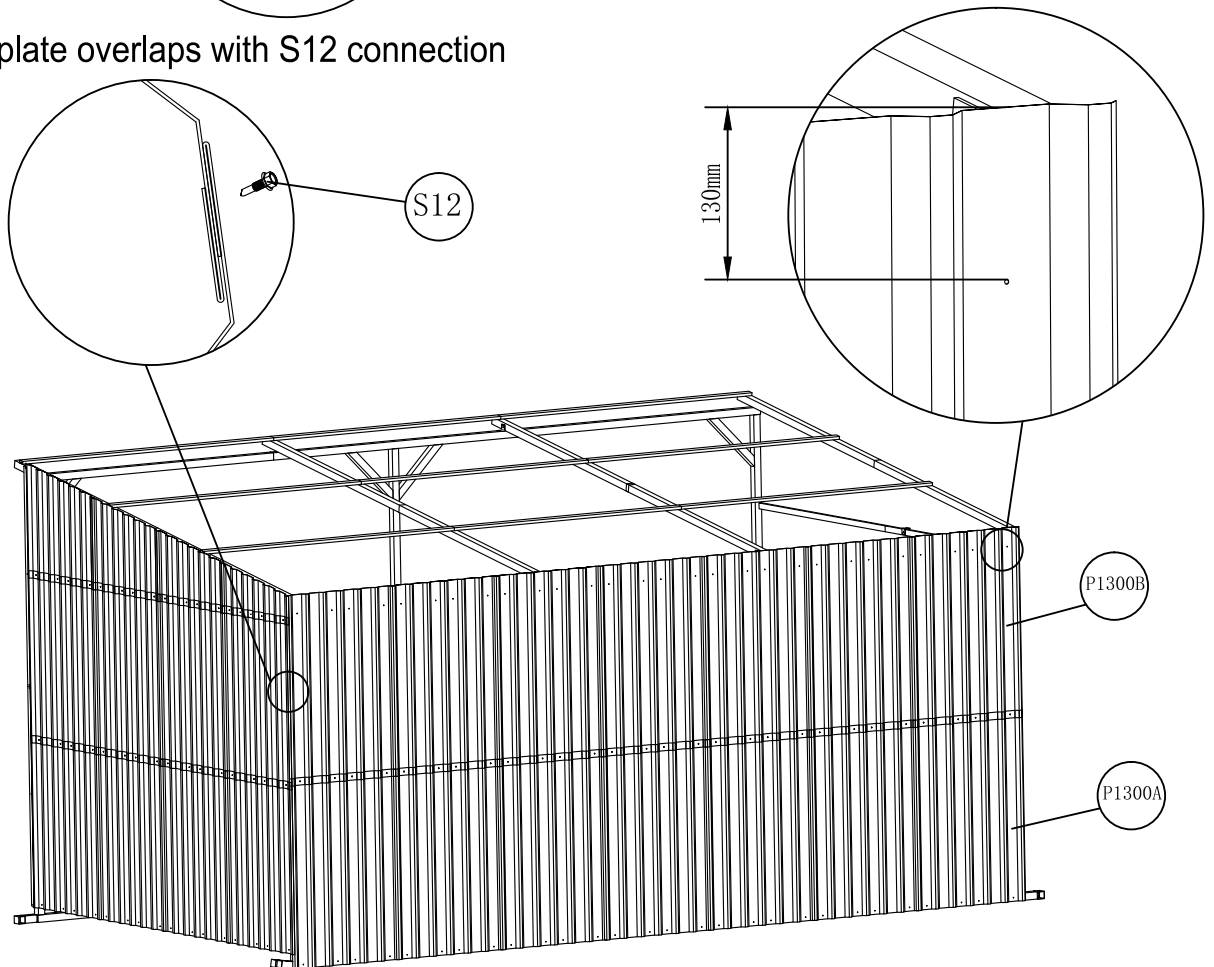

# PANEL ASSEMBLY

## STEP 3

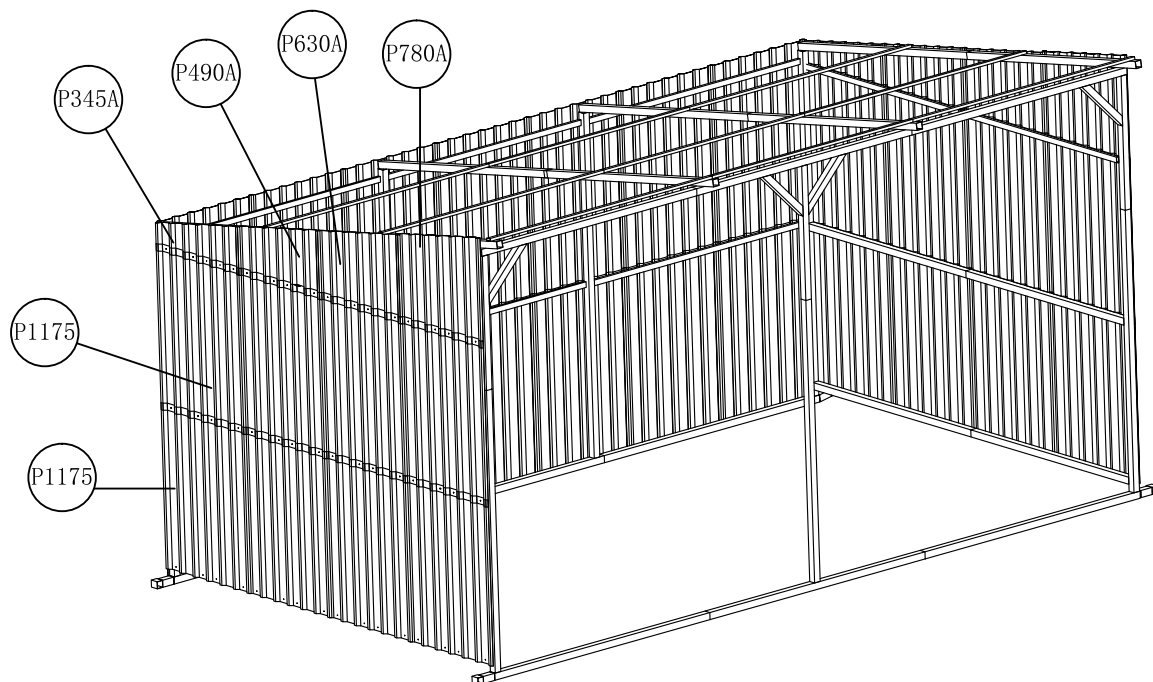

## STEP 4

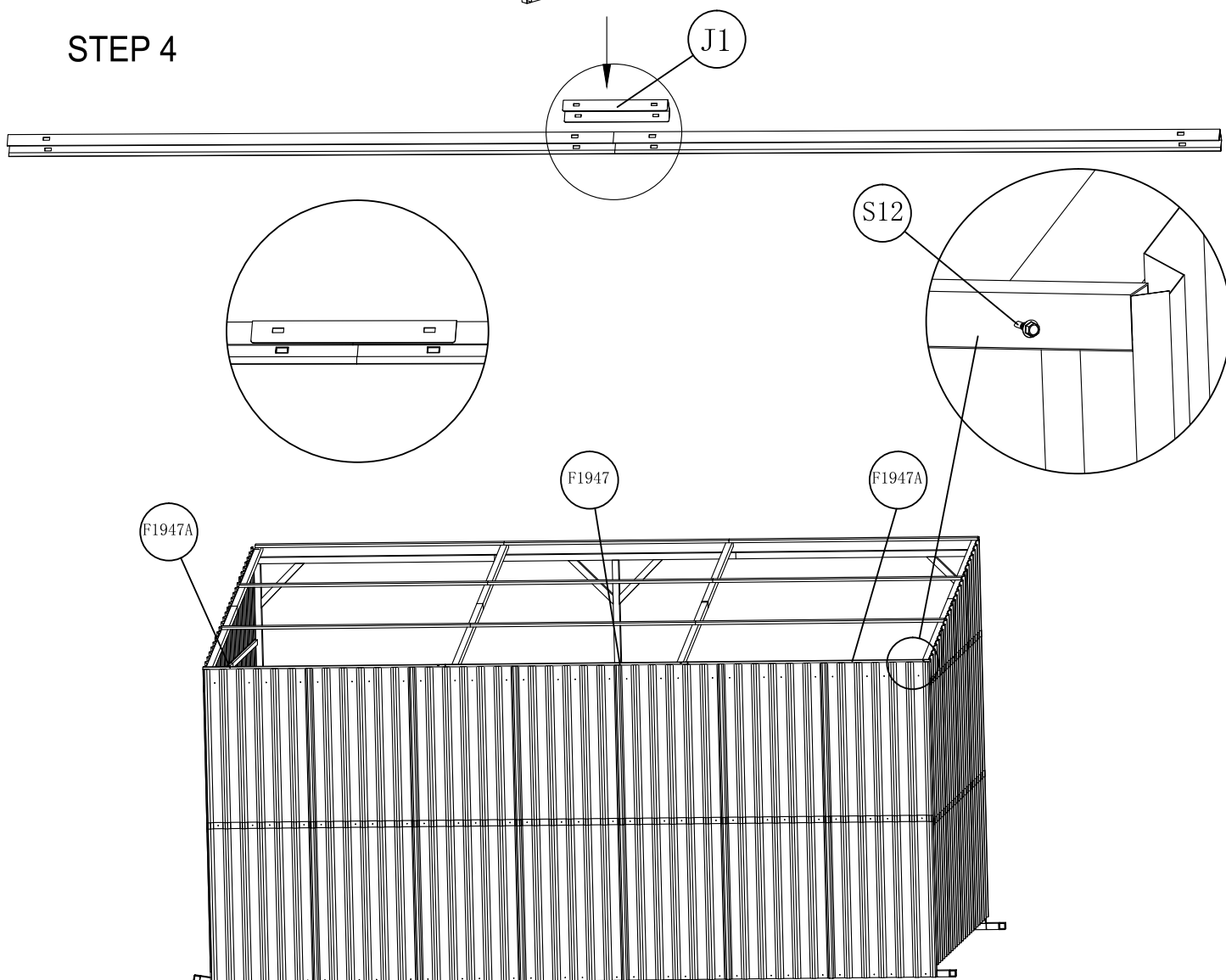

# PANEL ASSEMBLY

## STEP 5

When two panels overlap, make sure upper panel covers the lower panel.

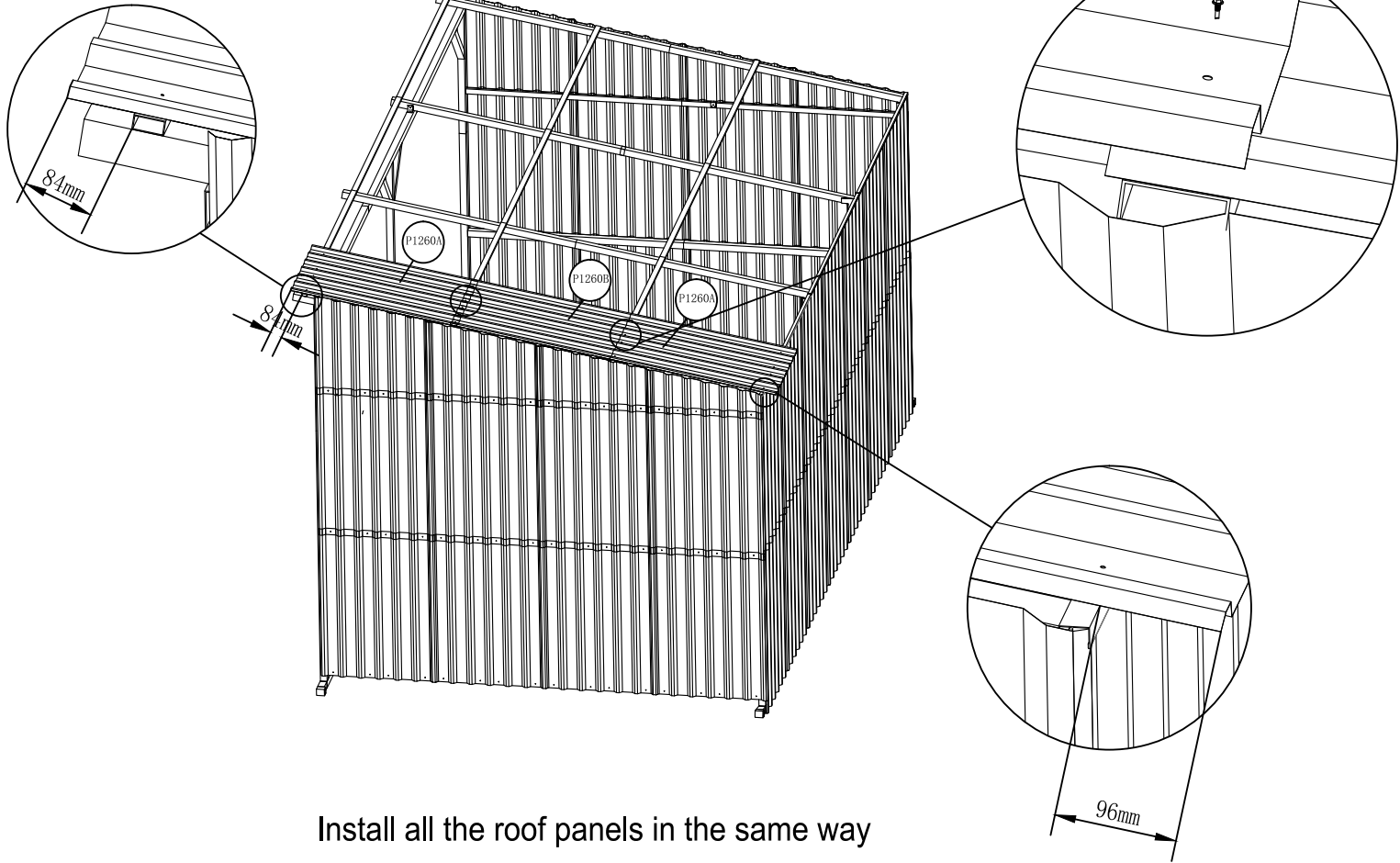

Install all the roof panels in the same way

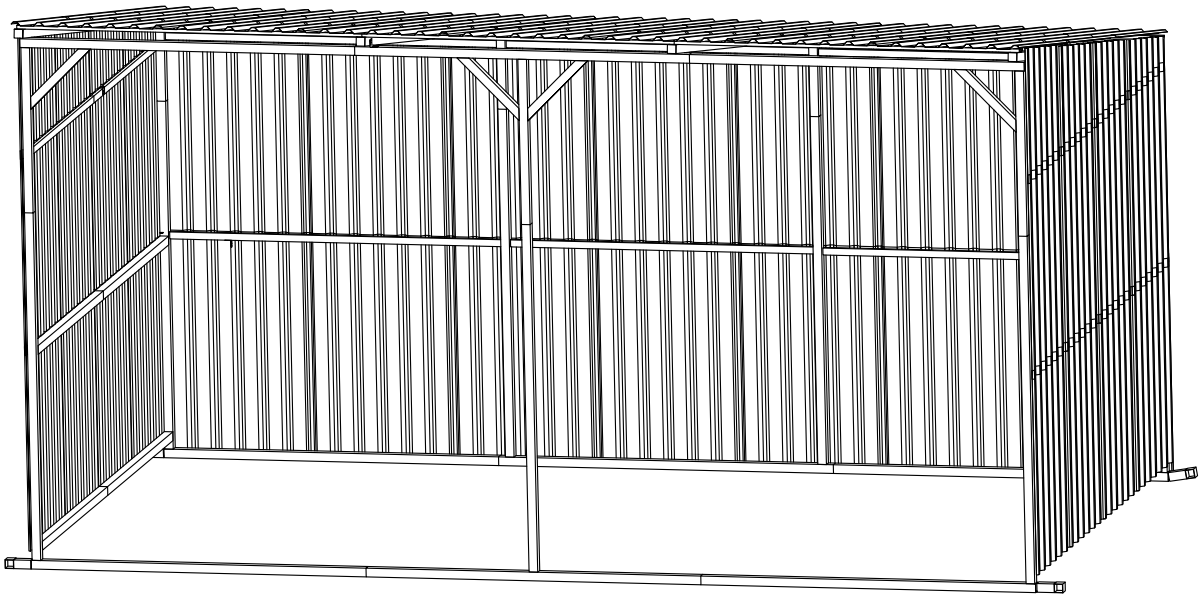

# SHED ASSEMBLY

STEP 6

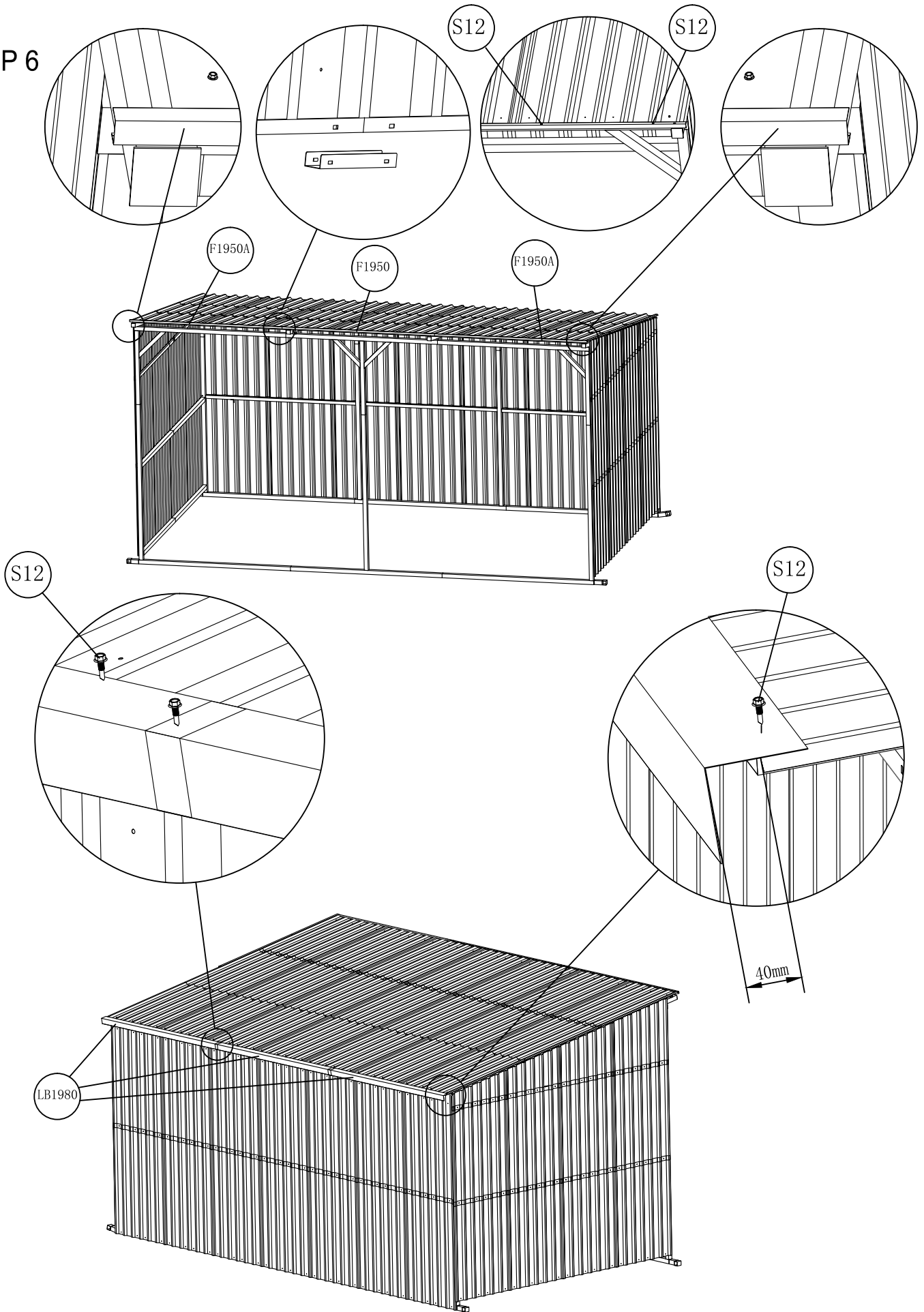



# SHED ASSEMBLY

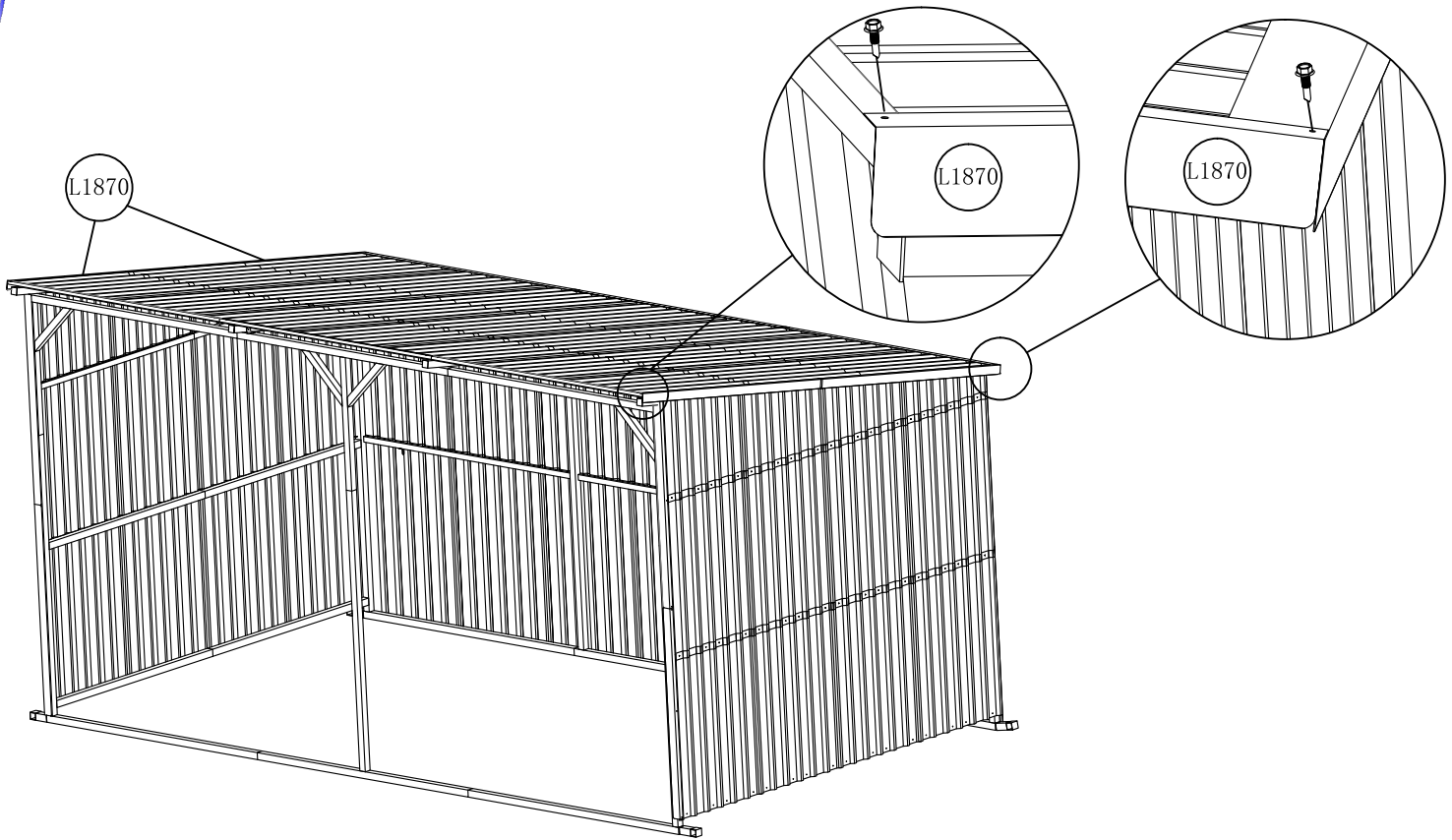

## STEP 9

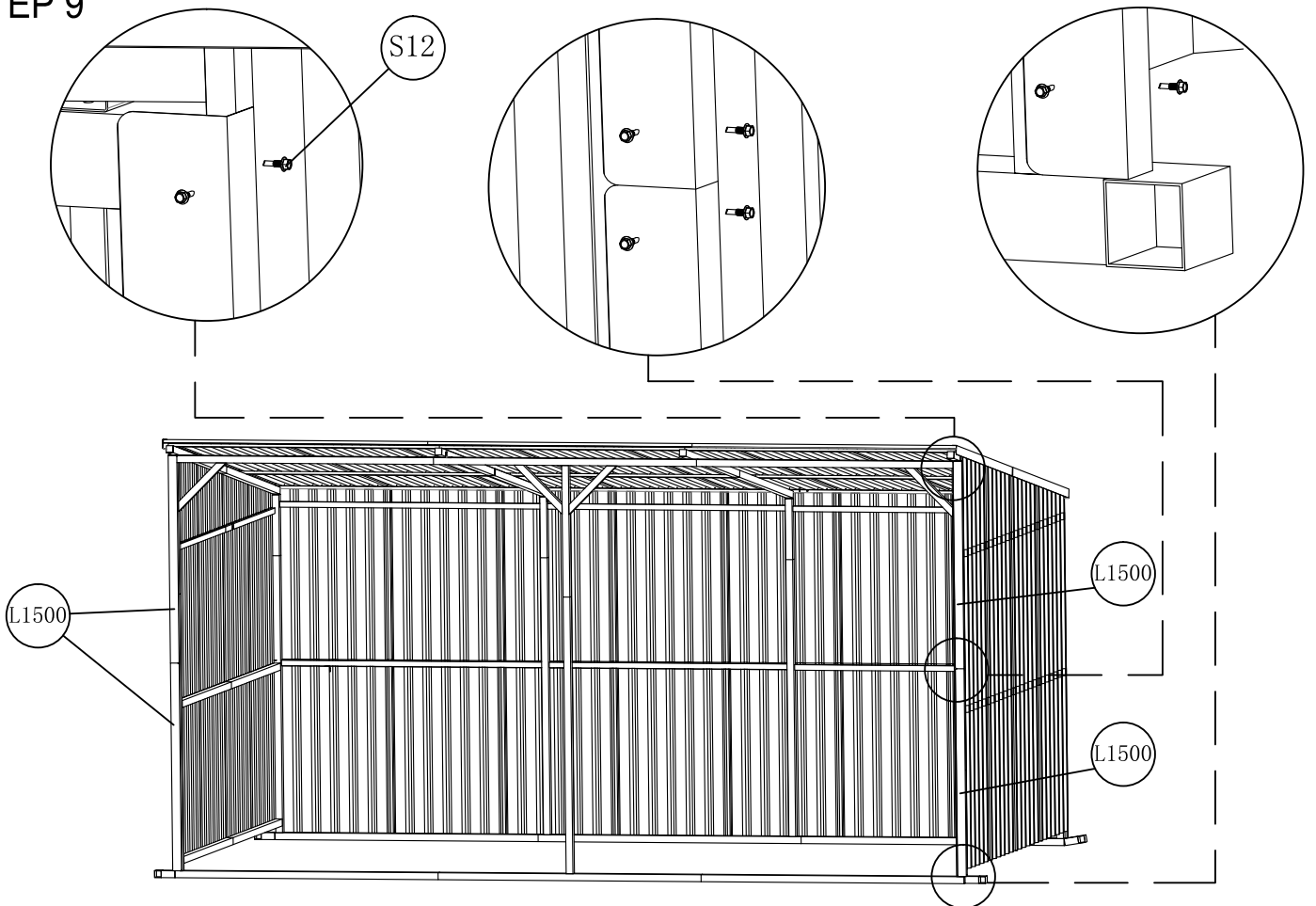



STEP 10

