

25' ORNAMENTAL SLIDING METAL GATE



⚠ WARNING



- Please read and understand the product manual completely before assembly
- Check against the parts list to make sure all parts are received
- Wear proper safety goggles or other protective gears while in assembly
- Do not return the product to dealer. They are not equipped to handle your requests.







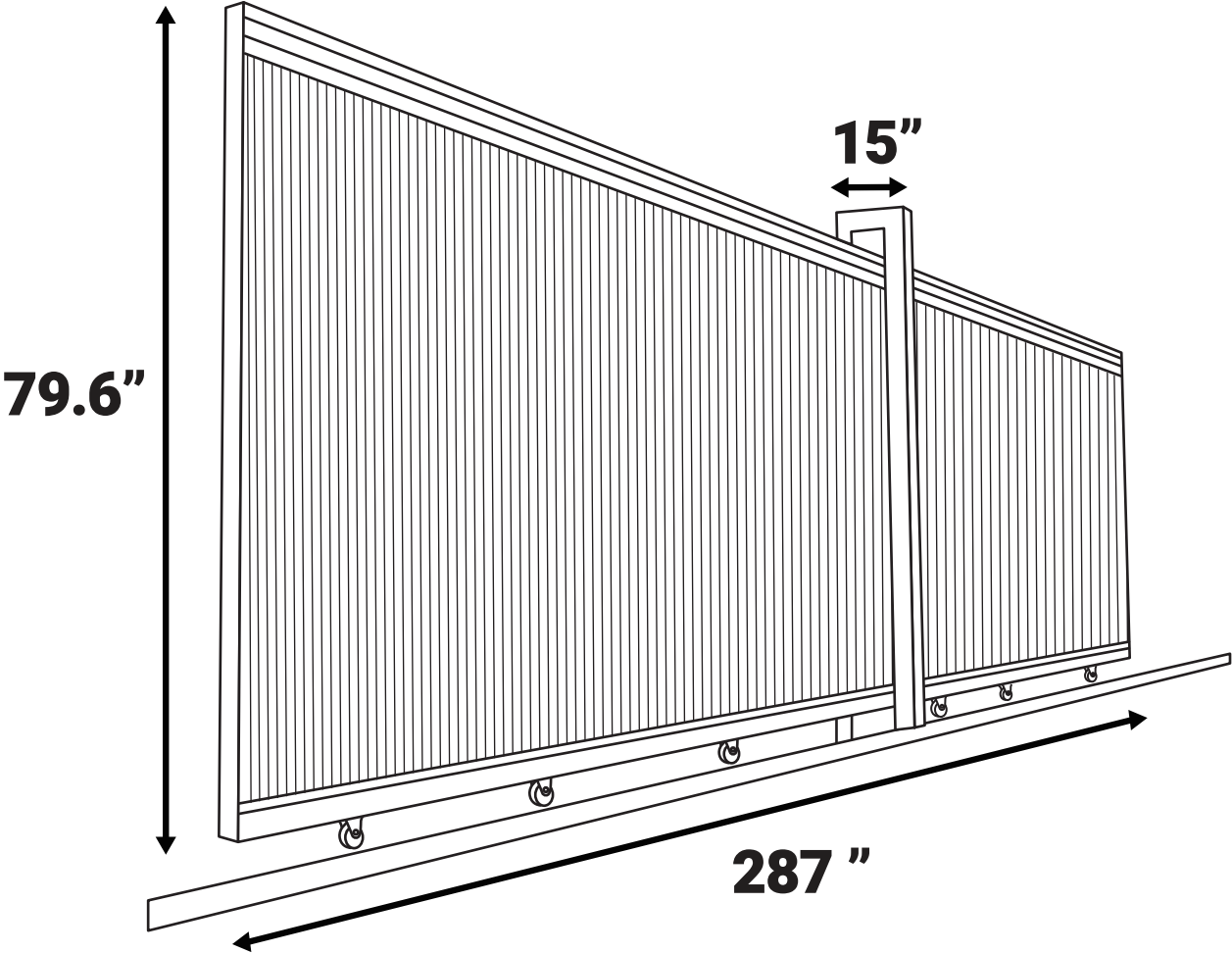

Missing parts or have questions on assembly?

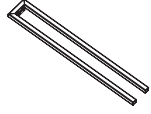
Please call: 1-877-761-2819 or email: cs@tmgindustrial.com

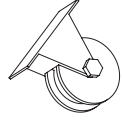
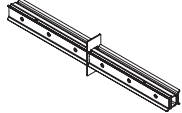
Frame structure diagram

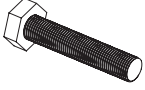

ACCESSORIES LIST

TMG-MGS25 PART LIST			
NO.	PICTURE	DESCRIPTION	QUANTITY
1		Rail Track	5
2		Columns	1
3		Clamping wheels	2
4		Orbital wheel	6
5		Connector	4
6		25ft centre gate	1
7		Side gate	2
8		M10x50 screws	24
9		M10 Nut	24
10		M10 gasket	48
11		plastic plugs	48

TMG-MGS25 INSTALLATION INSTRUCTIONS

STEP 1

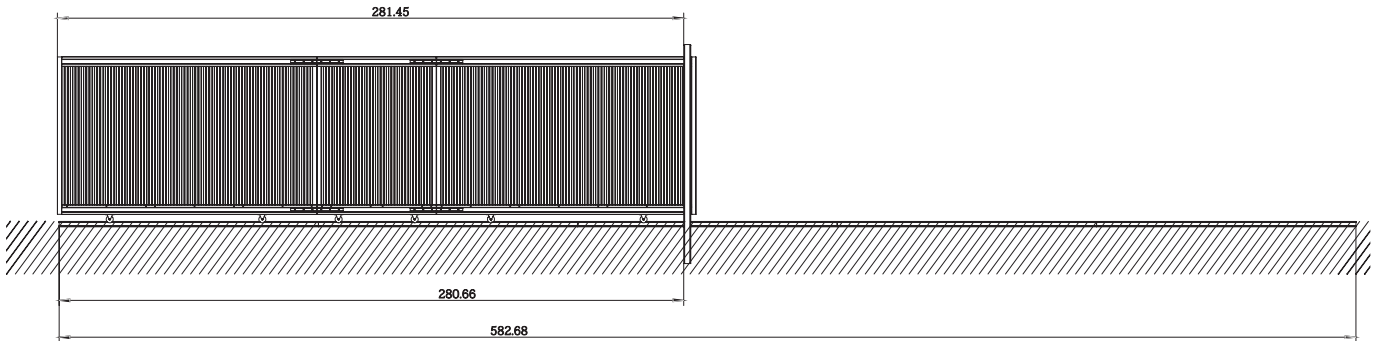

As shown in the picture

1. TMG-MGS25 track requires a pre-determined length of 582.68"
2. The TMG-MGS25 gate has a maximum opening and closing length of 281.45"
3. TMG-MGS25 column mounted on track 280.66"



Caution:

1. Column installation can be adjusted to the actual gate stack size
2. It is recommended that this TMG-MGS25 gate stack distance does not exceed 275"

STEP 2

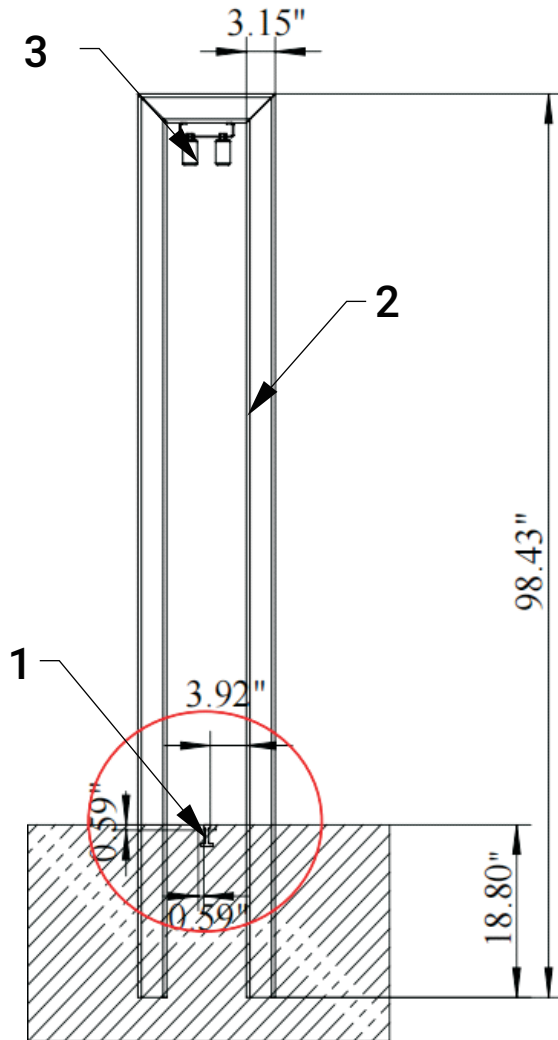
Column installation

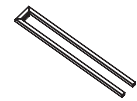

No.	Part	Qty
1		5
2		1
3		2

As shown in the picture

1. It is recommended that the TMG-MGS25 column pit size be (L*W*H) 32"*20"*20", with the column centrally placed in the pit at the appropriate location, and poured with C30 concrete as shown.

Caution:

1. Pre-embedded dimensions to be constructed in strict accordance with the dimensions shown
2. The columns need to be fixed with brackets after the concrete has been poured to ensure a vertical position.

STEP 3

Rail Track installation

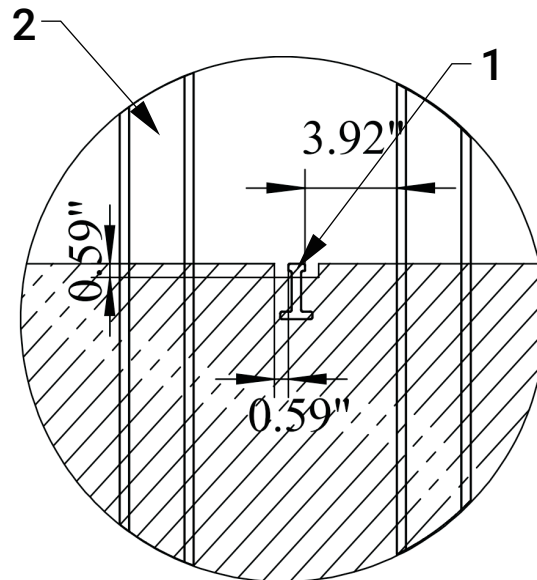

1. Cut a (L*W*H) 600"*6"*2.4" track pit in the middle of the column
2. Place the 5 PCS rails supplied with the kit in the pit in order and ensure that they are level, no connection between the rails is required
3. C30 concrete 1.7" thick was poured into the pit after the track was placed there

Caution:

1. The track is concreted with the required travel space for the track wheels in accordance with the dimensions shown on the drawings
2. It is recommended that the gate are installed 3 days after the concrete has been poured.
3. It is recommended that the concrete is drenched twice a day after pouring to ensure maximum curing requirements are met and to prevent cracking of the concrete.
4. If the installation is to be carried out in winter it is recommended to add antifreeze to the concrete and to insulate it.
5. After pouring the concrete for the track pit, the track wheels can be removed from the kit to verify that the concrete has been poured to the correct size.

STEP 4

Orbital wheel installation

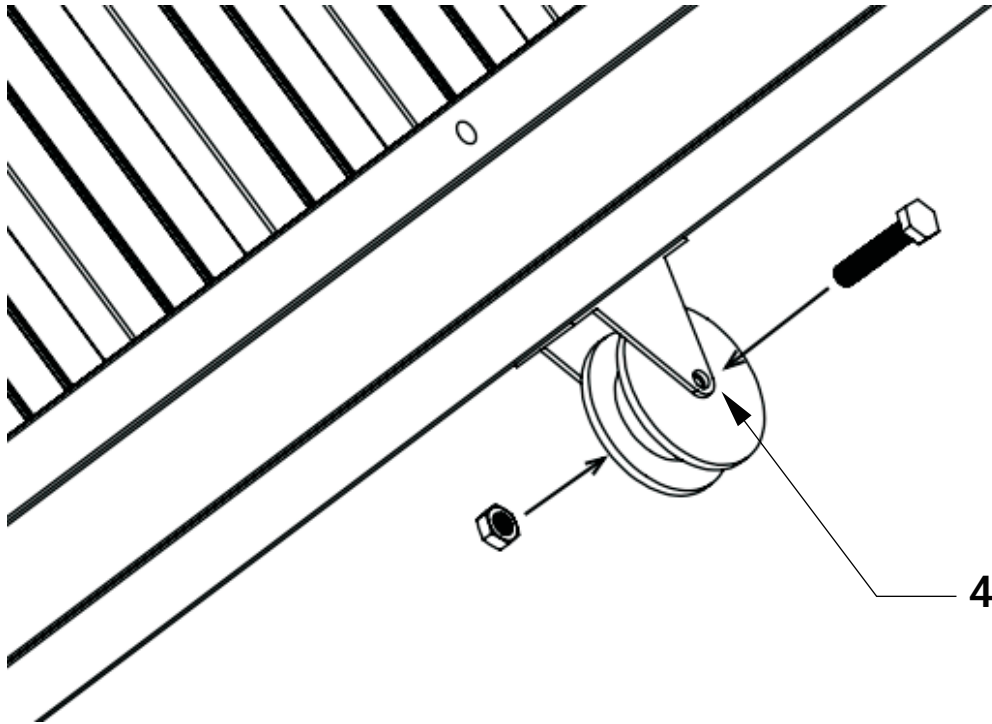

No.	Part	Qty
4		6

1. Remove the track wheel from the kit and install it with the screws and nuts supplied with the track wheel in the direction of the arrow shown

STEP 5

25ft centre gate installation

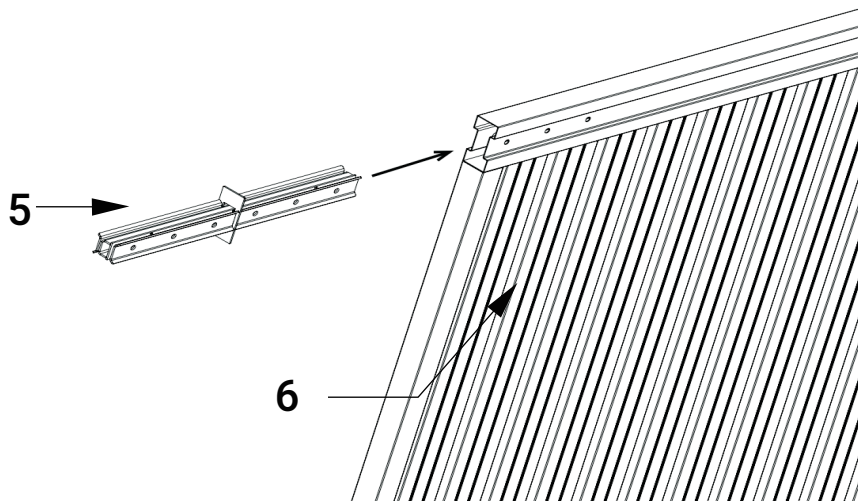
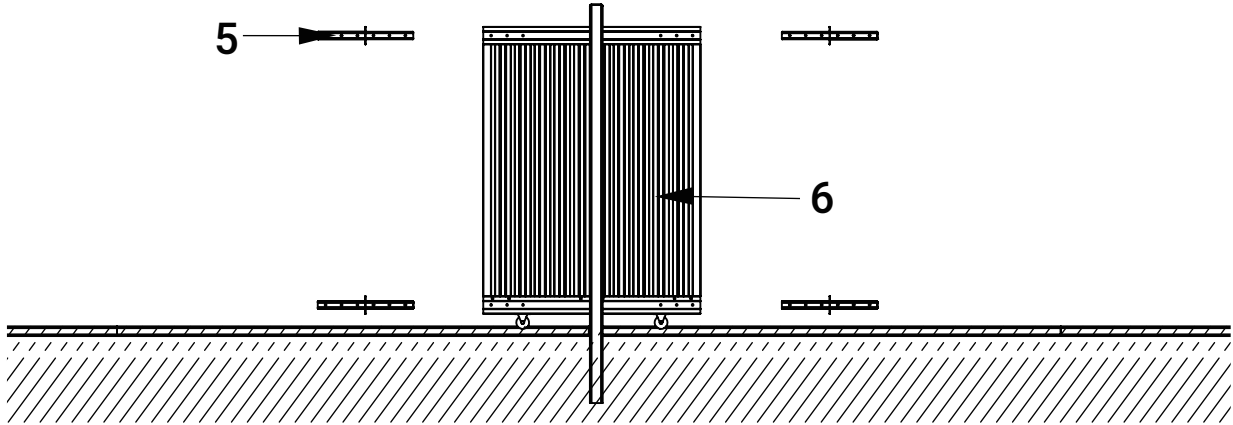

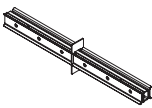
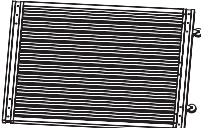



No.	Part	Qty
5		4
6		1

1. Place the centre gate track wheel on the track and push it into the middle of the column clamp wheel
2. Insert the connection pieces supplied with the kit into the connection slots in the centre gate

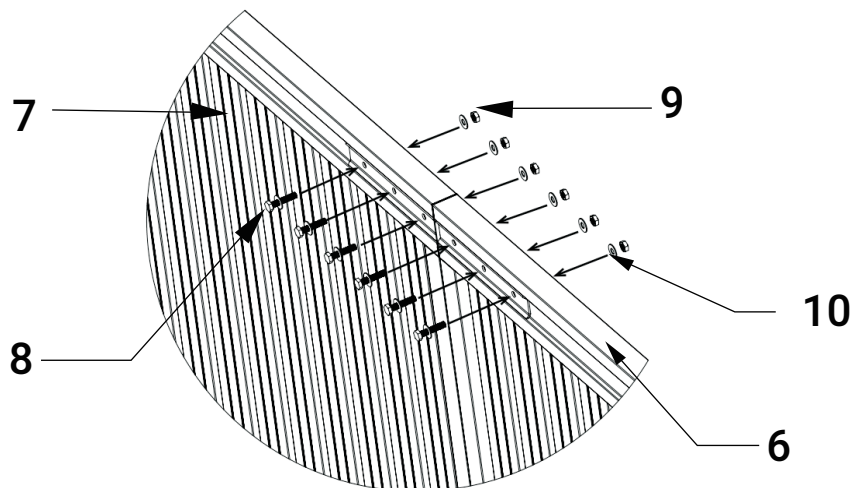
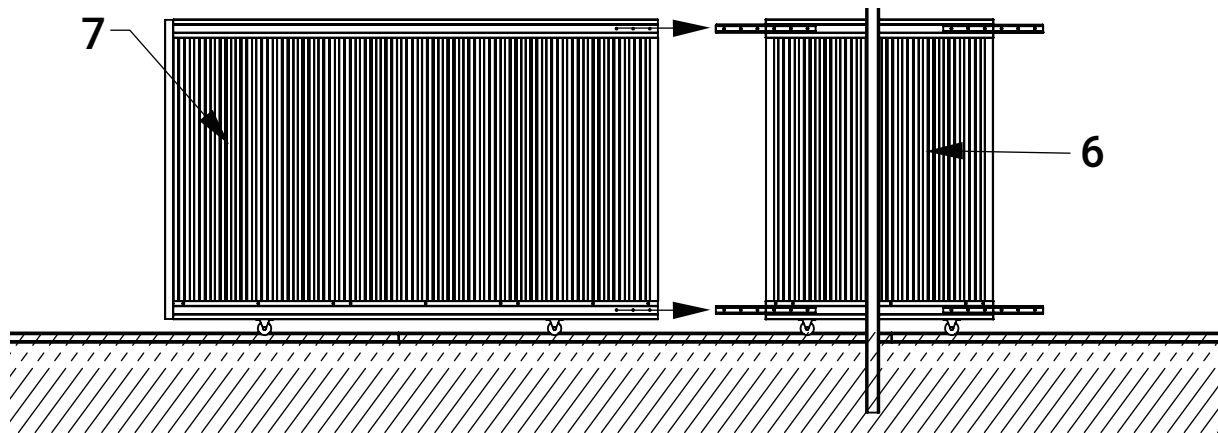
STEP 6

Left side gate installation



No.	Part	Qty	No.	Part	Qty
7		1	9		12
8		12	10		24





1. Place the left-hand side on the track and push it into the connector in the direction of the arrow to connect to the centre gate.

2. Fastened with M10*50 screws and M10 gasket M10 screws from the kit

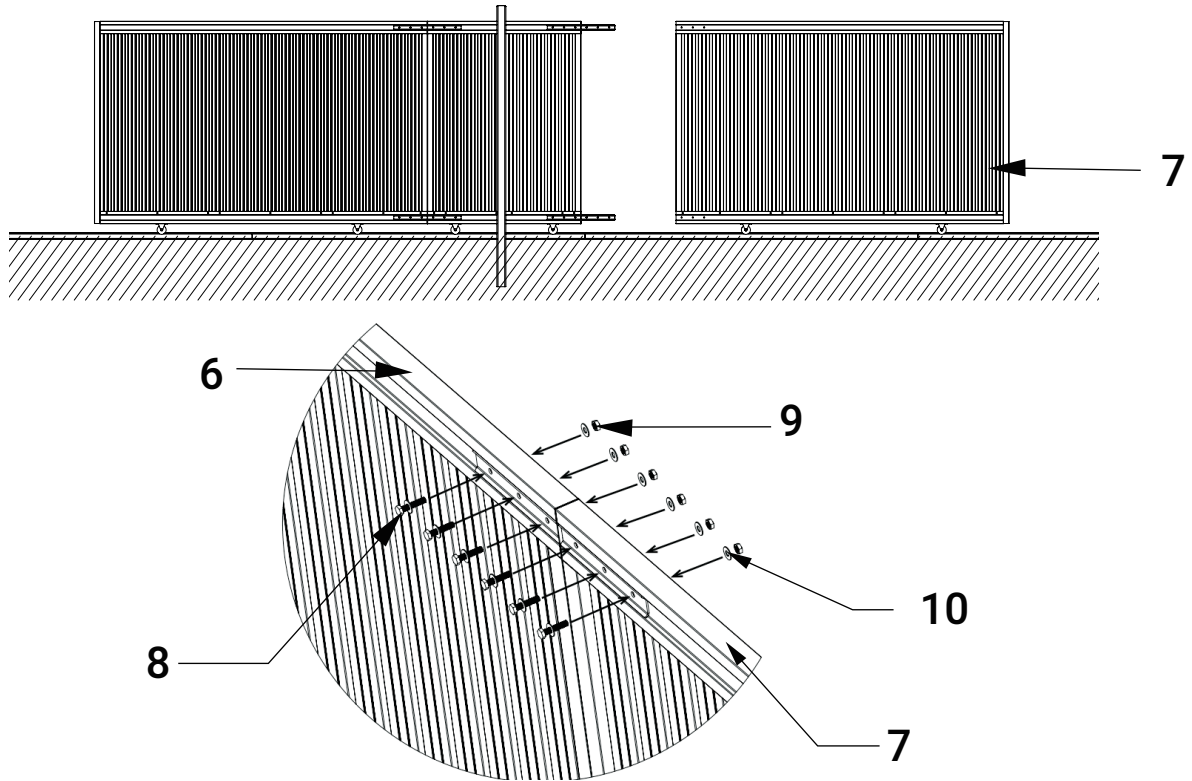
STEP 7

Right side gate installation



No.	Part	Qty	No.	Part	Qty
7		1	9		12
8		12	10		24

1. Place the right-hand side on the track and push it into the connector in the direction of the arrow to connect to the centre gate.
2. Fastened with M10*50 screws and M10 gasket M10 screws from the kit

Caution:

1. There are 3 people working on the track and column pre-burial, and more than 3 people working on the gate installation. A full set of labour protection equipment must be worn during the construction process to prevent injuries caused by negligence.
2. The side gate does not distinguish between left and right

STEP 8

Installation complete

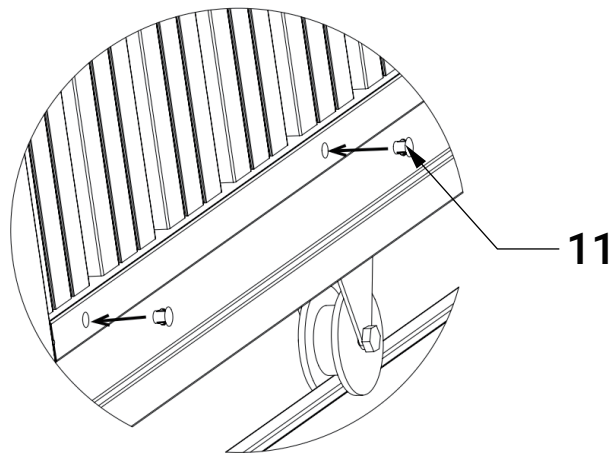
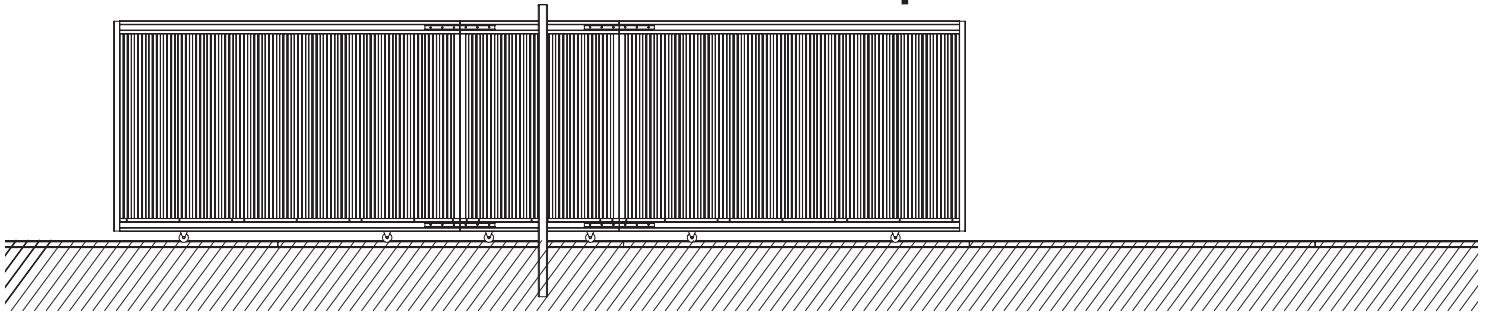

No.	Part	Qty
11		48

Caution:

- 1.The TMG-MGS series doors are laser cut to ensure accurate positioning during installation. The slight shrinkage caused by the welding process is normal and does not affect the overall installation.
- 2.The TMG-MGS range of gate all have holes reserved for the customer to install the gate opener rack, which can be plugged with plastic plugs from the kit if not required.