

**MODEL TMG-LPG10**

# 10ft x 10ft Aluminum Louvred Pergola

**⚠ WARNING**

- Please read and understand the product manual completely before assembly
- Check against the parts list to make sure all parts are received
- Wear proper safety goggles or other protective gears while in assembly
- Do not return the product to dealer. They are not equipped to handle your requests.

**Missing parts or questions on assembly?**

Please call: 1-877-761-2819 or email: [cs@tmgindustrial.com](mailto:cs@tmgindustrial.com)

## **Main Specifications:**

- Assembly size : W2.95 x L2.95 x H2.5 (m) / 10ft x 10ft x 8ft

## **Prior to assembly**

Please go through the whole instruction manual completely. It is very important to follow your local safety regulations and industry standards during installation.















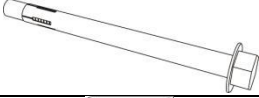

Regulations may include but are not limited to:





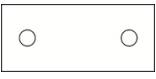





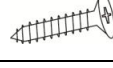

- Safety helmets, protective eyewear, and clothing
- Safety harnesses for all elevated workers
- Proper ladder, cage, and safety operation

Check all components and parts before installation. All parts are marked with a part number, please refer to the parts list to ensure you have all parts.

Choose a day with low or no wind to install, it is hard to assemble with heavy wind. Do not make any alterations to the structure. Do not hang any weight on the frame during installation, including parts. We are not responsible for any damages or injuries caused by inappropriate installation, unauthorized modifications or extreme weather.

Check the parts list below to make sure all parts are received prior to assembly.



TMG-LPG10 Part List				
Parts code	Graphical	Description	Length	Qty
A1		Post	110X110mm	4
A2		Base cover	190X190mm	4
A3		Base footing plate	170X170mm	4
A4		Base footing screw	4X35mm	24
A5		Expansion bolt	M8X7mm	16
A6		Post cover	110X110mm	4
A7		Post cover screw	4X16mm	24
A8		Small cover	18X18X2	4
B1		Beam B1	80X140mm	1
B2		Beam B2	80X140mm	1
B3		Beam B3	80X140mm	1
B4		Beam B4	80X140mm	1
B5		Rubber plug	8mm	40
B6		Sliding pin	35*17mm	42
B7		Sliding pin screw	4*16mm	84
C1~C21		Blade	149.98*43.8mm	21
C44		Letters	6*8*8mm	1
D1		L shape aluminum plate	25*15mm	2

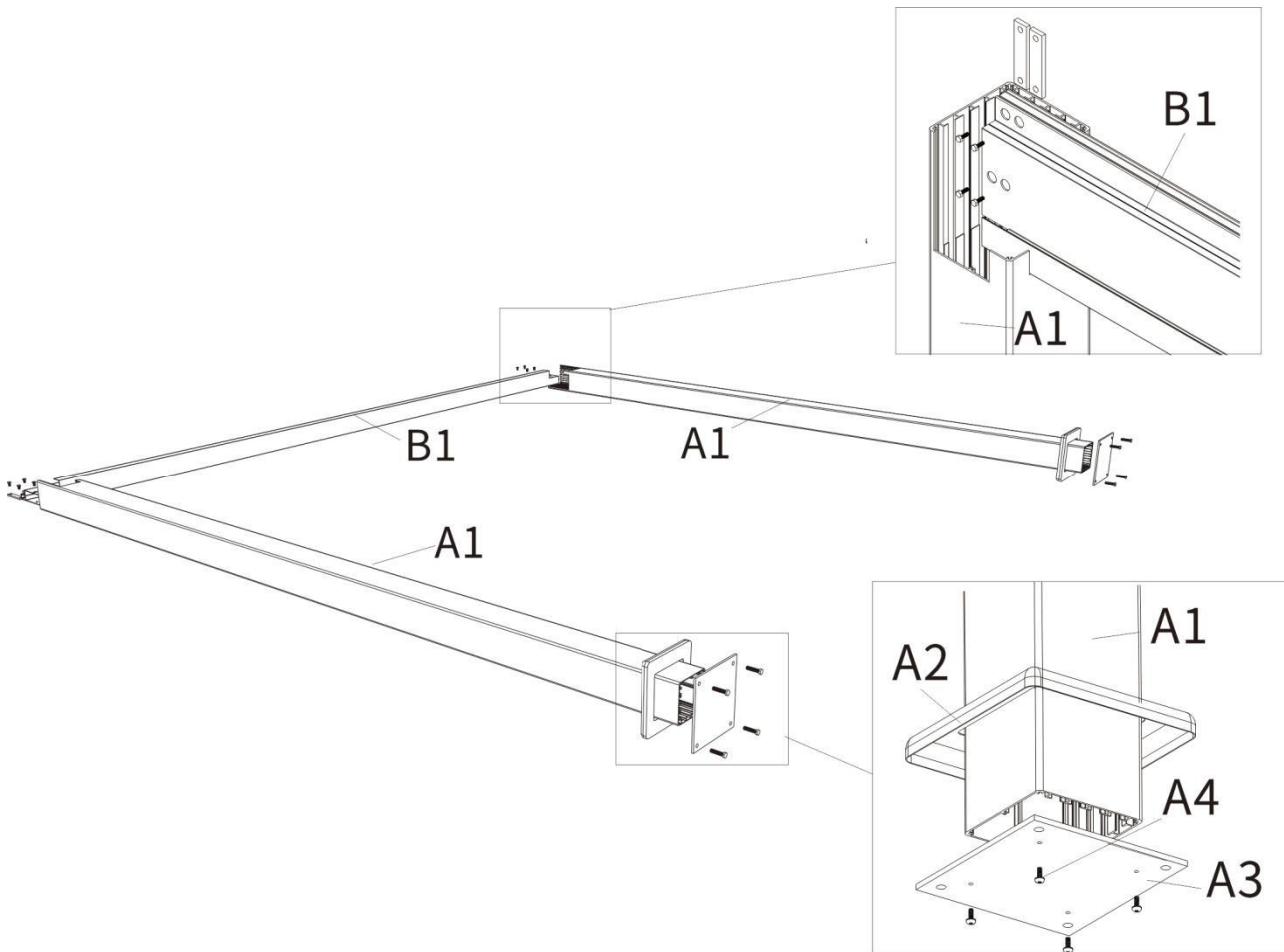

<b>E</b>		R-shape pin	1.8*35mm	42
<b>F1</b>		Front breakwater	65*15mm	1
<b>F2</b>		Front breakwater screw	4*16mm	3
<b>G1</b>		Rear breakwater	125*26mm	1
<b>G2</b>		Rear breakwater screw	4*16mm	5
<b>H</b>		Hexagon spanner	3mm	2
<b>I</b>		Pergola remote control		1
<b>J</b>		Small rubber hammer	26*6*2mm	1
<b>K</b>		Phillips bit	65mm	2
<b>L</b>		Drill Bit	3.4mm	1
<b>N</b>		Silicon sealant	120ml	1
<b>T</b>		Hand crank	1600mm	1

### Step 1: Install Base footing plate and Beam

- Lay the post A1 flat, install base cover A2 and base footing plate A3 on all post A1, and drilling base footing screw A4. The step applies to the two post on the right
- Install the beam, insert the ends of beam B1 into two post A1, and tighten the screws

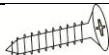

Parts code	Graphical	Qty
A1		4
A2		4
A3		4
A4		16

B1		1
B3		1

## Step 2: Install Beam B2&B4.

- Install Beam B2\B4 on the Post A1,as shown.

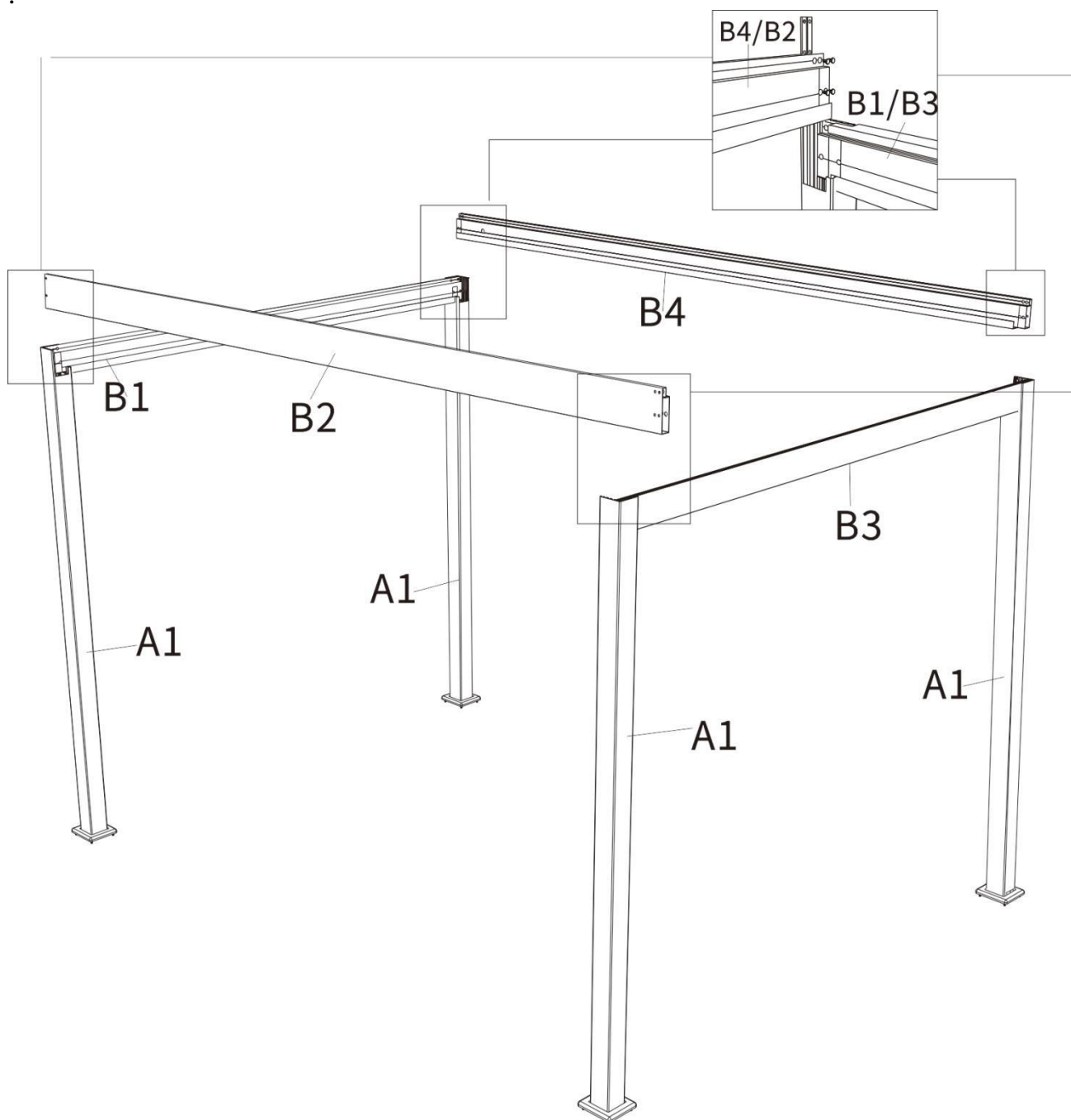

B2		1
----	---	---

B4		1
----	---	---

**Step 3: Install Base footing plate A3.**

- Measuring base distance, make the parallel distances and the diagonal distances equal.
- Secure the base footing plate A3 with expansion bolt A5.

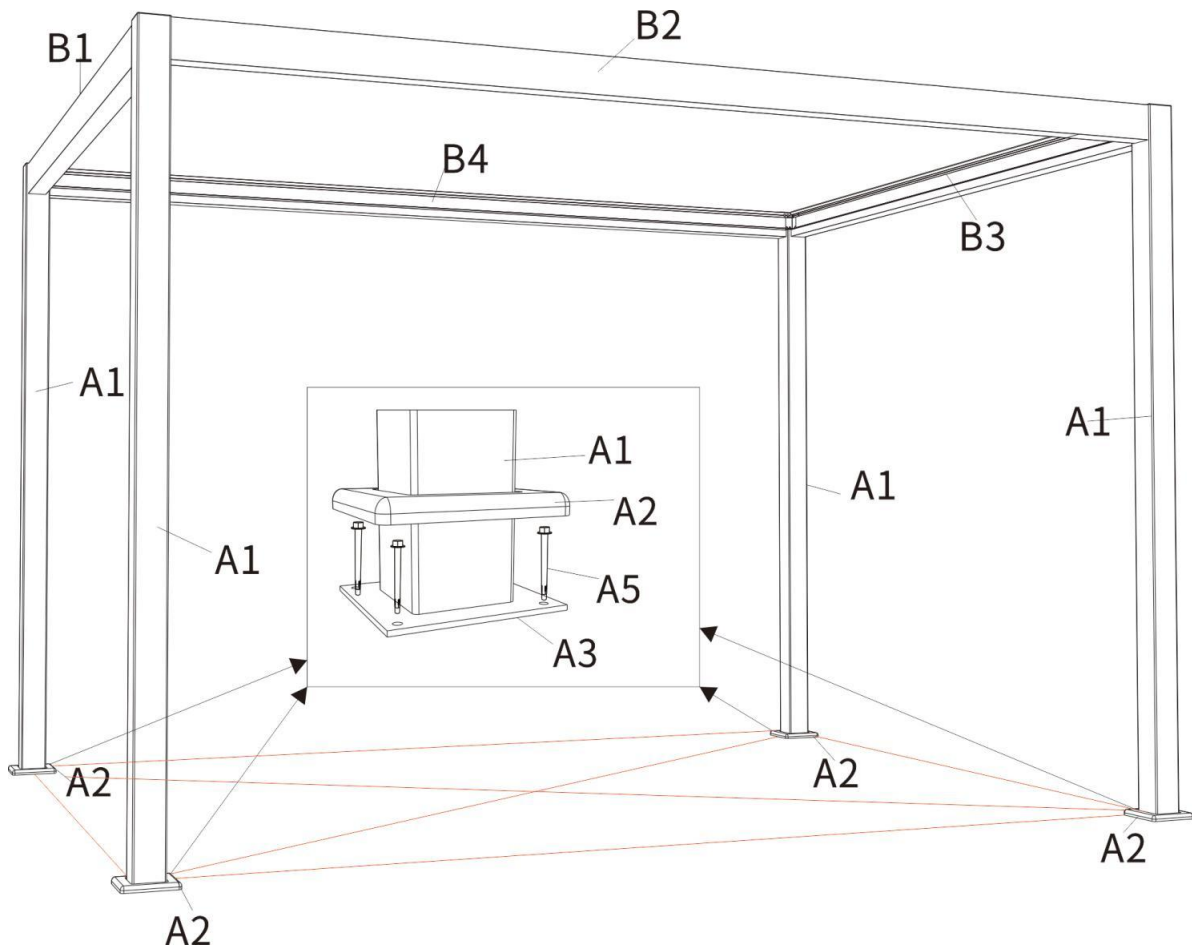

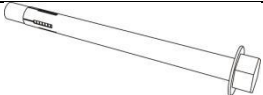



Parts code	Graphical	Qty
A5		16

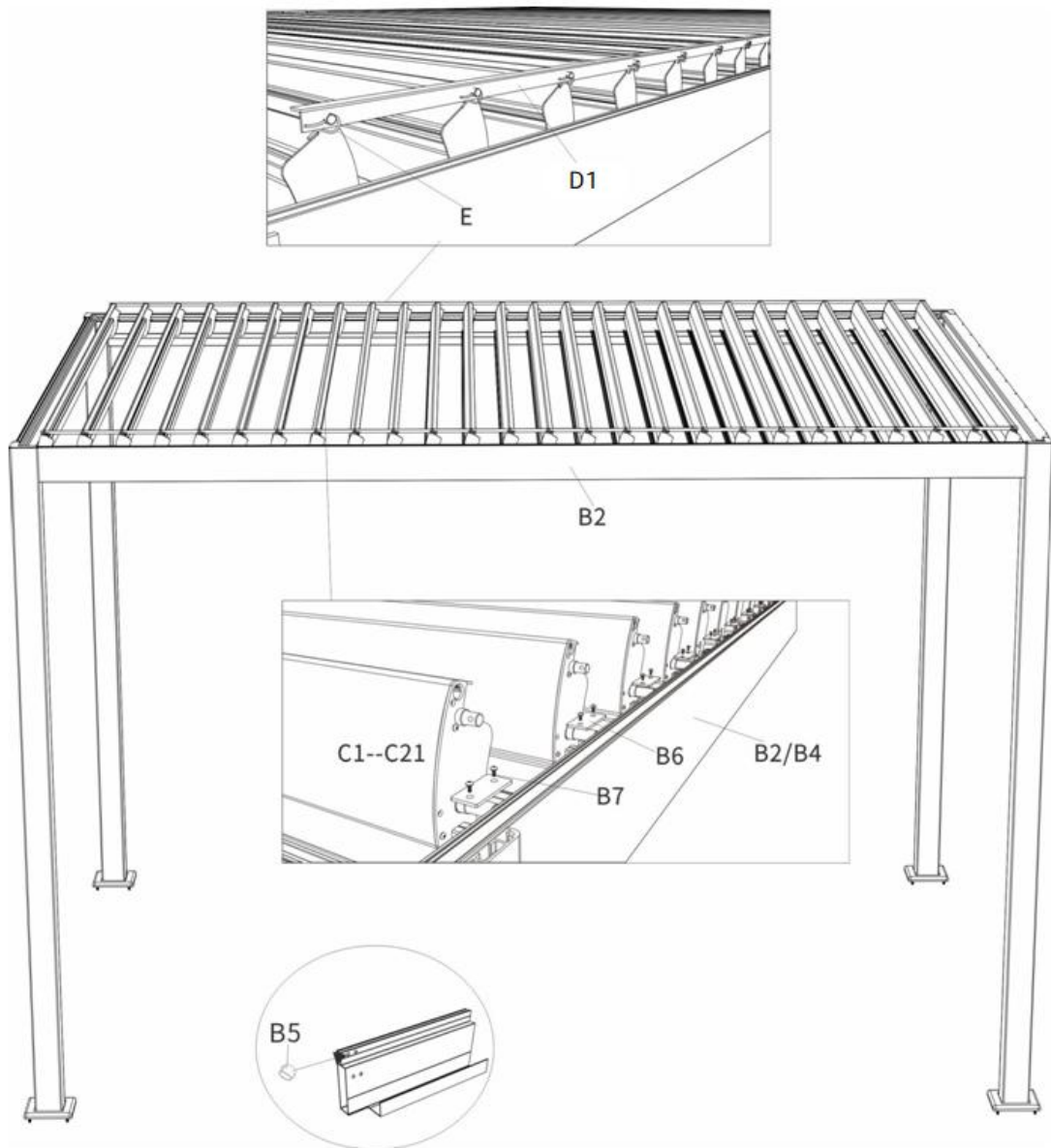

**Step 5: Install Blades C1-C21.**

- Install the blades C1--C21 in sequence, and drill the sliding pin screw B7 into sliding pin B6 to fix it.
- Connect all the blades with L shape aluminum D1 & D2, and plug R-shape pin E as shown.

- All screw hole plugs with small rubber plug B5.



Parts code	Graphical	Qty
C1-C21		21
B5		40
B6		42

D2		1
E		42
B7		84



**Step 6: Install Front breakwater F1 and Rear breakwater G1**

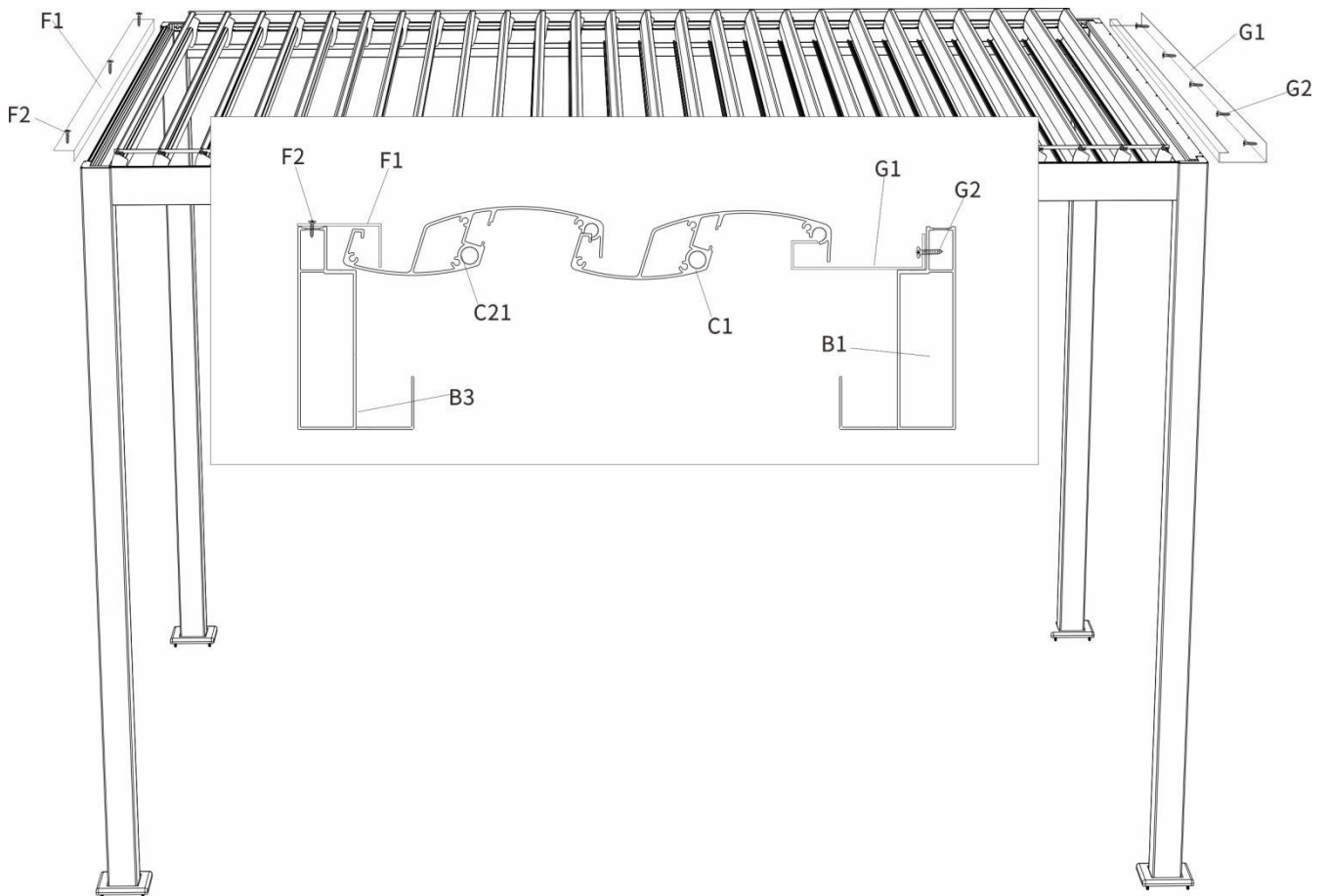



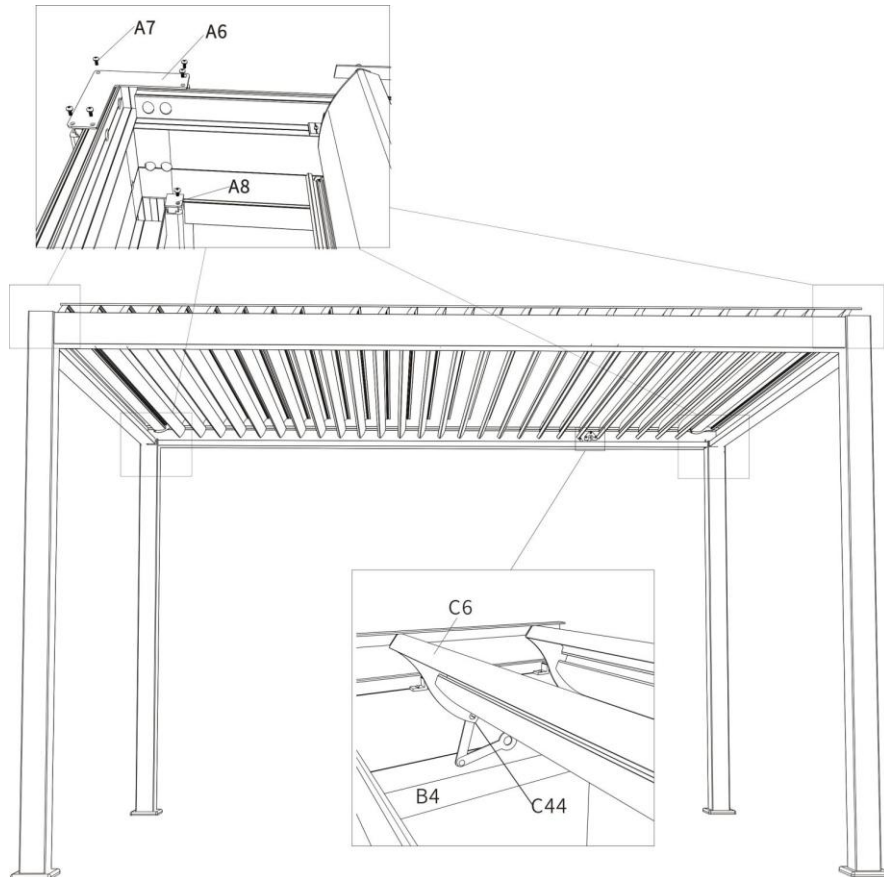

Parts code	Graphical	Qty
F1		1
F2		3

G1		1
G2		5

## Step 7: Install post cover A6



Parts code	Graphical	Qty
A6		4
A7		24

A8		4
C44		1