

# Rotary Surface Cleaner Washer

4000PSI, 21" Surface Cleaner, 16" Water Broom

**MODEL: TMG-GSW40**

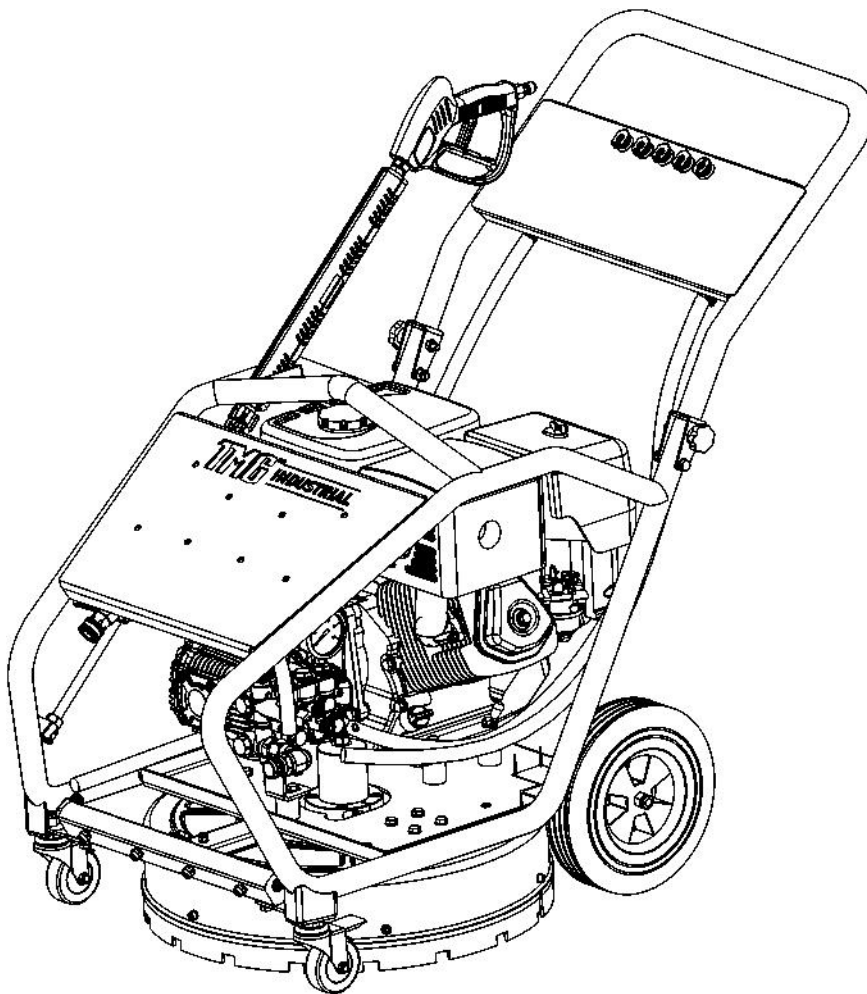

- Please read the product manual completely before assembly
- Check against the parts list to make sure all parts are received
- Wear proper safety goggles or other protective gears while in assembly

Missing parts or questions on assembly?

Please call: 1-877-761-2819 or email: [cs@tmgindustrial.com](mailto:cs@tmgindustrial.com)

Do not return the product to dealer, they are not equipped to handle your requests

# Contents

1. Introduction.....	02
2. Products Identification.....	03
3. Safety Guidelines.....	03
4. Products Specifications.....	07
5. Parts Identification and Features.....	08
6. Unpacking & Assembly.....	12
7. Setting Up the Before Use.....	12
8. Safe Working Environment.....	15
9. Start up and Stopping Procedure.....	16
10. Operation.....	17
11. Stopping the Pressure Washer.....	18
12. Using Nozzles.....	18
13. Adjusting Spray Pressure.....	19
14. Using Chemicals & Detergents.....	19
15. Maintenance.....	20
16. Storage.....	22
17. Troubleshooting.....	23
18. Pressure Washer Exploded View & Parts List.....	26

## Disclaimer:

The information in this document is to the best of our knowledge true and accurate, but all recommendations or suggestions are made without guarantee. Since the conditions of use are beyond their control, the factory disclaim any liability for loss or damage suffered from the use of this data or suggestions. Furthermore, no liability is accepted if use of any product in accordance with this data or suggestions infringes any patent. The factory reserve the right to change product specifications and warranty statements without further notification. All images are for illustration purposes only.

## 1. Introduction

Thank you for purchasing this **Professional Power Equipment Product**.

Please read the following instructions carefully to help to ensure your personal safety and the correct assembly, use and maintenance of this equipment. Please ensure that you have read and understand the information contained in the manual before attempting to use the equipment. This equipment should only be used by trained and fully competent individuals, in a safe working environment. Please ensure that the appropriate safety equipment is worn at all times and that the product is not adapted or modified in anyway.

Please note that the contents of this instruction manual are based on the latest product information available at the time of publication and that the manufacturer reserves the right to make changes at any time without notice.

## 2. Products Identification

### RECORD IDENTIFICATION NUMBERS

If you need to contact an Authorized Dealer for information on servicing, always provide the product model and identification numbers. You will need to locate the model, revision and serial number for the machine and record the information in the places provided below. You will also need the model and serial number for the engine on your machine.

1. Date of Purchase: \_\_\_\_\_

2. Dealer Name: \_\_\_\_\_

3. Dealer Phone: \_\_\_\_\_

4. Unit Model Name: \_\_\_\_\_

5. Pump Model & Serial Number: \_\_\_\_\_

6. Engine Model & Serial Number: \_\_\_\_\_

**NOTE:** Check the article 5.1 (page 7) for the location of the pump model & serial no. on the pump. Check the engine operators manual for the location of these numbers.

## 3. Safety Guidelines



### WARNING- READ AND FOLLOW ALL INSTRUCTIONS

- Failure to follow all instructions in this manual may result in severe personal injury or death. Keep this manual and refer to it for Safety Instructions, Operating Procedures, and Warranty.



This manual contains information that is important for you to know and understand. This information relates to protecting **YOUR SAFETY** and **PREVENTING EQUIPMENT PROBLEMS**. To help you recognize this information, we use the symbols below. Please read the manual and pay attention to these sections.



### DANGER

**DANGER** indicates an imminently hazardous situation which, if not avoided, will result in death or serious



### WARNING

**WARNING** indicates a potentially hazardous situation which, if not avoided, could result in death or serious injury.



### CAUTION

**CAUTION** indicates a potentially hazardous situation which, if not avoided, may result in minor or moderate



### CAUTION

**CAUTION** used without the safety alert symbol indicates a potentially hazardous situation which, if not avoided, may result in property damage.

Improper maintenance and operation are responsible for the majority of accidents involving gas pressure washers. The largest portion of these could be prevented by recognizing the basic safety rules and precautions. Most accidents can be avoided if the operator recognizes a potentially hazardous situation before it happens and by observing appropriate safety rules and procedures as outlined in this manual. Basic safety precautions are outlined in the **SAFETY** portion of this manual and throughout the text in this manual where a potential hazard might occur. Hazards that **MUST** be avoided to prevent serious injury follow headers marked **DANGER** or **WARNING**. These same precautions are placed as labels on the tool itself. **NEVER** use this pressure washer for applications that are **NOT** specified in this manual.

### 3. Safety Guidelines (continued)



#### DANGER- RISK TO BREATHING

- Running engine gives off carbon monoxide, an odorless, colorless, poison gas.
- Breathing carbon monoxide can cause nausea, fainting or death.
- Some chemicals or detergents may be harmful if inhaled or ingested, causing severe nausea, fainting or poisoning.



- **ALWAYS** Operate pressure washer in a well ventilated area. Avoid enclosed areas such as garages, basements ,etc.
- **ALWAYS** Keep exhaust gas from entering a confined area through windows, doors, ventilation intakes, or other openings.
- **ALWAYS** follow manufacturers recommendations, use a respirator or mask whenever there is a chance that vapors may be inhaled.
- **ALWAYS** use the only fluids specifically recommended for high pressure washers.
- **NEVER** operate unit in a location occupied by humans or animals.
- **NEVER** use chlorine bleach or any other corrosive compound.



#### DANGER-RISK OF EXPLOSION OR FIRE

- Fuel and its vapors are extremely flammable and explosive.
- Fire or explosion can cause severe burns or death.



**ALWAYS** shut off engine and allow it to cool a least 2minutes before adding fuel to the tank.

**ALWAYS** use care in filling tank to avoid spilling fuel. Move pressure washer away from fueling area before starting engine.

**ALWAYS** Keep maximum fuel level below top of tank to allow for expansion.

**ALWAYS** operate and fuel equipment in well ventilated areas free from obstructions. Equip areas with fire extinguishers suitable for gasoline fires.

**ALWAYS** keep pressure washer a minimum of four feet away from surfaces (such as houses, automobiles, or live plants) that could be damaged from muffler exhaust heat.

**ALWAYS** store fuel in an OSHA approved container, in a secure location away from work area.

**NEVER** spray flammable liquids

**NEVER** operate pressure washer in an area containing dry brush or weeds.



#### WARNING-RISK OF FALL HAZARD

- Use of pressure washer can create puddles and slippery surfaces.
- Kickback from spray gun can cause you to fall.



- Keep the area of operation clear of all persons, particularly small children, pets and obstacles.
- Do not operate the product when fatigued or under the influence of alcohol or drugs. Stay alert at all times.
- If engine does not start after two pulls, squeeze trigger of gun to relieve pump pressure. Pull starter cord slowly until resistance is felt Then pull cord rapidly to avoid kickback and prevent hand or arm injury.
- Do not overreach or stand on an unstable support.
- The cleaning area should have adequate slopes and drainage to reduce the possibility of a fall due to slippery surfaces.
- Be extremely careful if you must use the pressure washer from a ladder, scaffolding, or any other similar location.
- Beware of kick-back force and the sudden torque on the spray gun assembly when operating the trigger. Firmly grasp spray gun with both hands to avoid injury when spray gun kicks back.

### 3. Safety Guidelines (continued)



#### WARNING-RISK TO FLUID INJECTION

- The high pressure stream of water that this equipment produces can cut through skin and its underlying tissues, leading to serious injury and possible amputation. Spray gun traps high water pressure, even when engine is stopped and water is disconnected, which can cause injury.

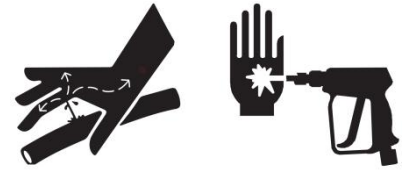

- **ALWAYS** point spray gun in safe direction and squeeze trigger, to release high pressure, every time you stop engine.
- **NEVER** place hands in front of nozzle.
- **MAKE SURE** hose and fittings are tightened and in good condition. Never hold onto the hose or fittings during operation.
- **DO NOT** allow hose to contact muffler.
- **NEVER** attach or remove wand or hose fittings while system is pressurized.
- **NEVER** use a spray gun which does not have a trigger lock or trigger guard in place and in working order.
- **ONLY USE** hose and high pressure accessories rated for pressure higher than your pressure washer's p.s.i. To relieve system pressure, shut off engine, turn off water simply, and pull gun trigger until water stops flowing.
- **DO NOT** allow **CHILDREN** to operate pressure washer.
- **NEVER** repair leaking connections with sealant of any kind. Replace o-ring or seal.
- **NEVER** connect high pressure hose to nozzle extension.
- **DO NOT** secure spray gun in open position.
- **DO NOT** leave spray gun unattended while machine is running.
- **ALWAYS** be certain spray gun, nozzles and accessories are correctly attached.
- **NEVER** aim spray gun at people, animals, or any electrical device and the machine itself.

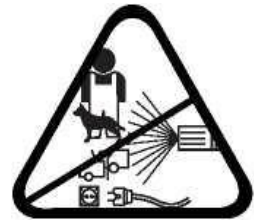

#### DANGER- RISK OF CHEMICAL BURN

- Use of acids, toxic or corrosive chemicals, poisons, insecticides, or any kind of flammable solvent with this product could result in serious injury or death.



- **DO NOT** use acids, gasoline, kerosene, or any other flammable materials in this product. Use only household detergents, cleaners and detergents recommended for use in pressure washers.
- Wear protective clothing to protect eyes and skin from contact with sprayed materials.
- **DO NOT** use chlorine bleach or any other corrosive compound.



#### WARNING-RISK OF ELECTRICAL SHOCK

- Risk of electrocution.
- Contact with power source can cause electric shock or burn.



- Unplug any electrically operated product before attempting to clean it.
- Direct spray away from electric outlets and switches.
- **NEVER** spray near power source.
- **DO NOT** touch the plug with wet hands.
- **WHEN SERVICING THE PRESSURE WASHER:** Disconnect the spark plug wire and place it where it cannot contact the plug. **DO NOT** check for spark with the plug removed. Use only approved spark plug testers.

### 3. Safety Guidelines (continued)



#### DANGER-- RISK OF HOT SURFACES

- Contact with hot surfaces, such as engines exhaust components, could result in serious burn.



- During operation, touch only the control surfaces of the pressure washer.
- Keep children away from the pressure washer at all times. They may not be able to recognize the hazards of this product.
- **DO NOT** let hoses come in contact with very hot engine muffler during or immediately after use of your pressure washer.
- **AVOID** hot exhaust gases.



#### DANGER- RISK OF MOVING PARTS

- Starter and other rotating parts can entangle hands, hair, clothing, or accessories.



- **NEVER** operate pressure washer without protective housing or covers.
- **DO NOT** wear loose clothing jewelry or anything that may be caught in the starter or other rotating parts.
- Tie up long hair and remove jewelry.



#### DANGER- RISK OF EYE INJURY

- Spray can splash back or propel objects.



- **ALWAYS** wear safety goggles when using this equipment or in vicinity of where equipment is in use.
- Before starting the pressure washer, be sure you are wearing adequate safety goggles.
- **NEVER** substitute safety glasses for safety goggles.



#### CAUTION-IMPROPER TREATMENT OF PRESSURE WASHER CAN DAMAGE IT AND SHORTEN ITS LIFE AND VOID YOUR WARRANTY

- **NEVER** pull water supply hose to move pressure washer. This could damage hose and/or pump inlet.
- **DO NOT** use hot water, use cold water only.
- **NEVER** turn water supply off while pressure washer engine is running or damage to pump will result.
- **DO NOT** stop spraying water for more than two minutes at a time. Pump operates in bypass mode when spray gun trigger is not pressed. If pump is left in bypass mode for more than two minutes internal components of the pump can be damaged.
- Before starting pressure washer in cold weather, check all parts of the equipment to be sure ice has not formed there.
- **DO NOT** use the pressure washer if excessive noise or vibration is present. Have it repaired immediately.

#### PLEASE WEAR PROPER APPAREL AND PROTECTORS



Proper Apparel



Electrically  
Non-conductive Gloves



Ear Protection



Nonskid Footwear

**TMG INDUSTRIAL** CHEM 40° 25° 15° 0° MODEL TMG-GWS40

**4000** MAX PSI **3-IN-1** SURFACE CLEANER  
PRESSURE WASHER  
WATER BROOM

**WARNING**

**RISK OF INJECTION OR SEVERE INJURY**

Do not touch the water jet.

TMG-MACH-4007

**WARNING**

Read and understand operators manual before using this machine.

Failure to follow operating instructions could result in death or serious injury.

TMG-MACH-4006

**DANGER**

**PRESSURE WASHER PROCEDURES**

- INSPECT EQUIPMENT BEFORE USE
- NEVER DIRECT SPRAY AT YOURSELF OR OTHERS
- FACE SHIELDS, SAFETY GLASSES, AND RAIN SUITS MUST BE WORN

TMG-MACH-4008

**WATER OUTLET CONNECTOR**

TMG-GMRL-0017

**CAUTION/AVERTIR**

**RISK OF PERMANENT EQUIPMENT DAMAGE!**  
Risque d'endommagement permanent à l'équipement

**ADD PUMP OIL** 10W/30 or 15W/40 **1/2**

Operating pump with low or no oil causes permanent damage. Add pump oil at 1/2 level of the oil sight glass. CHECK OIL BEFORE EVERY USE.

Operation du pompe avec un niveau bas d'huile, ou sans huile causent dommages permanent. Ajouter huile au niveau marqué de l'indicateur du niveau. VÉRIFIER NIVEAU D'HUILE AVANT CHAQUE USAGE!

The RED PLUG is for shipping only. Before first use, replace the red plug with the black VENTED PLUG.

Le Bouchon d'huile rouge est seulement pour transport. Avant opération initiale, accordez de remplacer le bouchon rouge avec bouchon noir aéré!

Running pump with NO WATER or DRY causes permanent damage, and VOIDS WARRANTY. CHECK WATER BEFORE EVERY USE!

Operation du pompe sans eau causera dommages permanent et annule la garantie. Vérifier niveau d'eau avant chaque usage!

TMG-MACH-4009

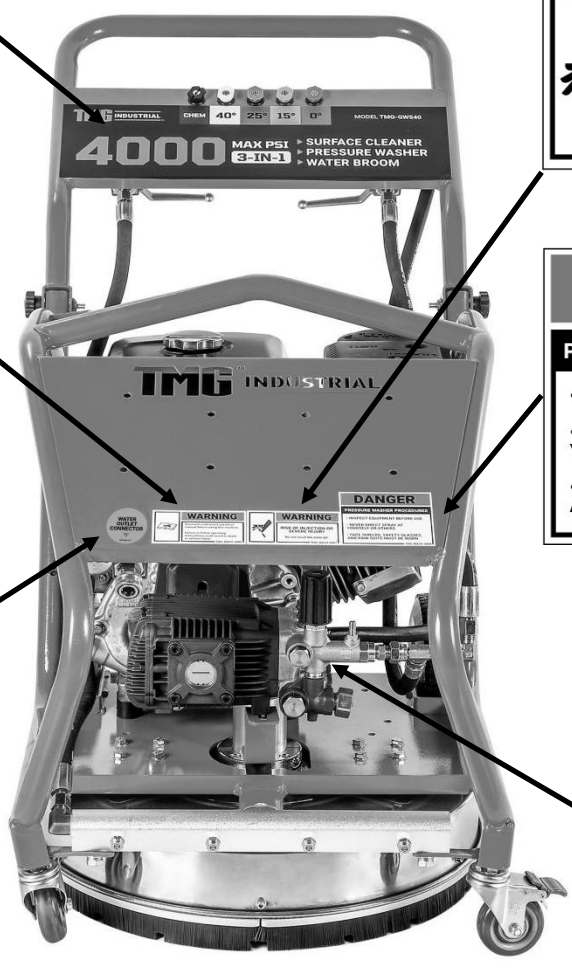

**4. Products Specifications**

Model No.	TMG-SCW40
Max Pressure	4000PSI
Max Flow	4.5GPM
Pump Model	TMG-PMP48, Triplex, Engine Direct Drive
Power and Type	KOHLER CH440, Manual Start
High Pressure Hose	ID5/16" x 30FT
Nozzle	0°, 15°, 25°, 40° and Soap
Surface Cleaner	21"
Water Broom	16"
Spray Gun	36"
Wheel	2PCS X 3", 2PCS X 10"
Shipping Weight	195 lb
Shipping Size	35"x23.5"x33"

# 5. Parts Identification and Features

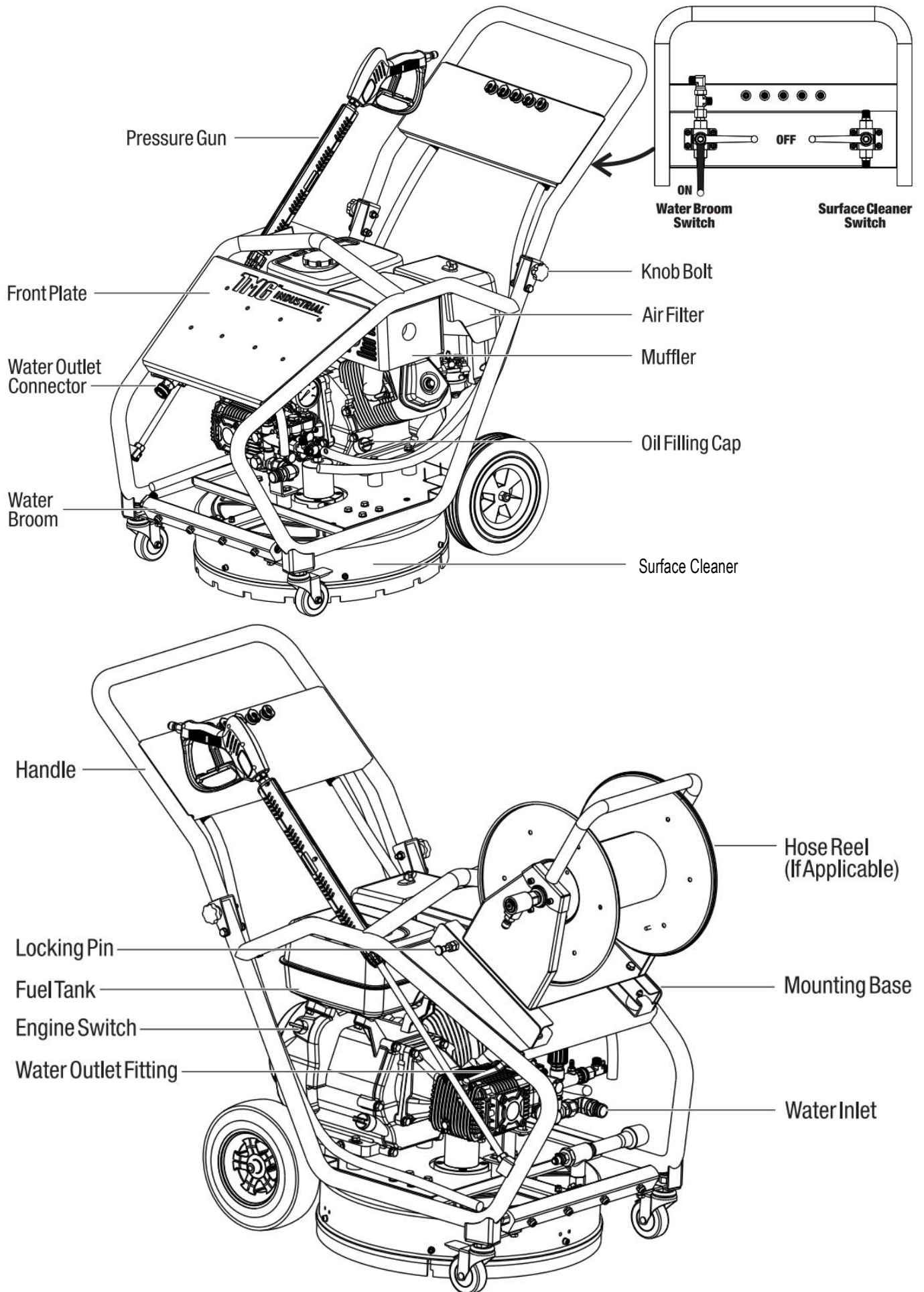



## 5. Parts Identification and Features (Continued)

### 5.1 Triplex Pump

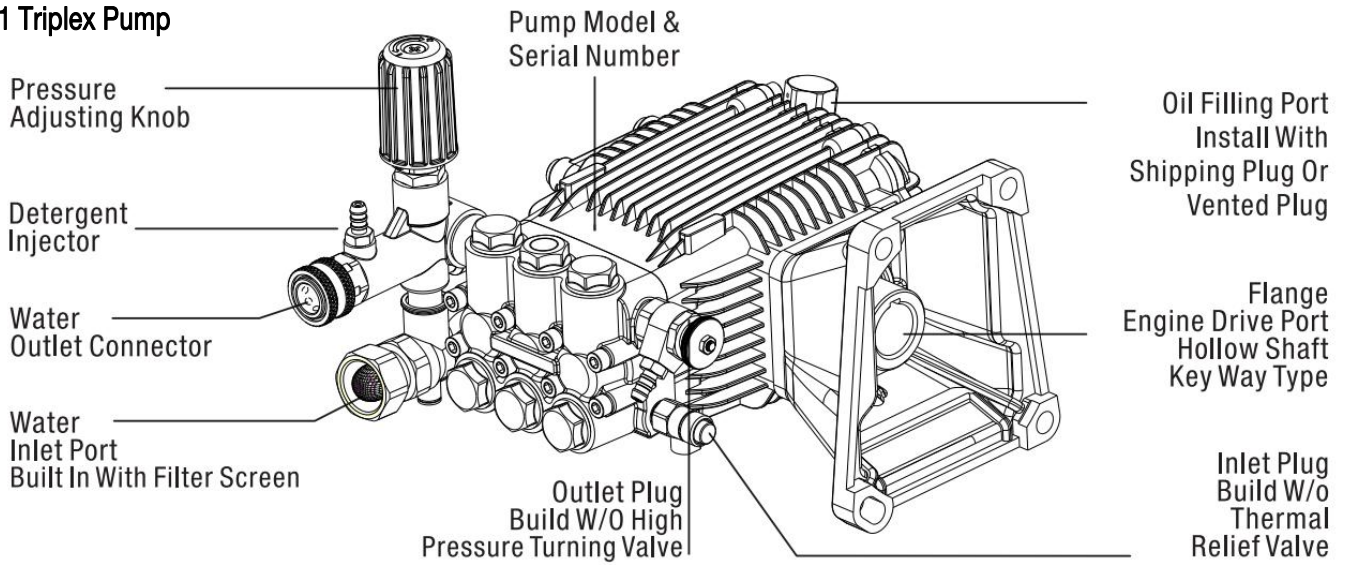

Adaptor Port For Pressure Gauge Or Priming Valve

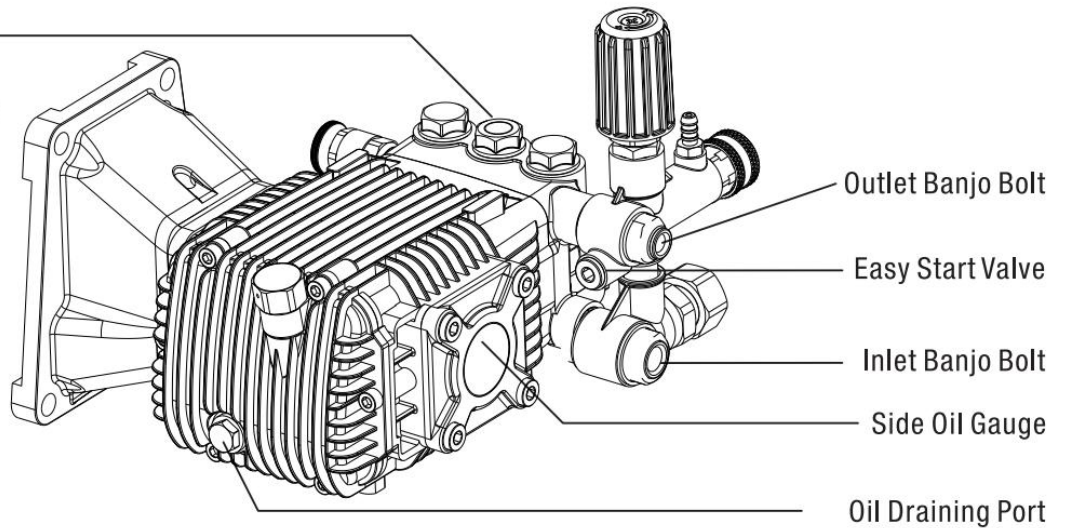

### 5.2 Surface Cleaner

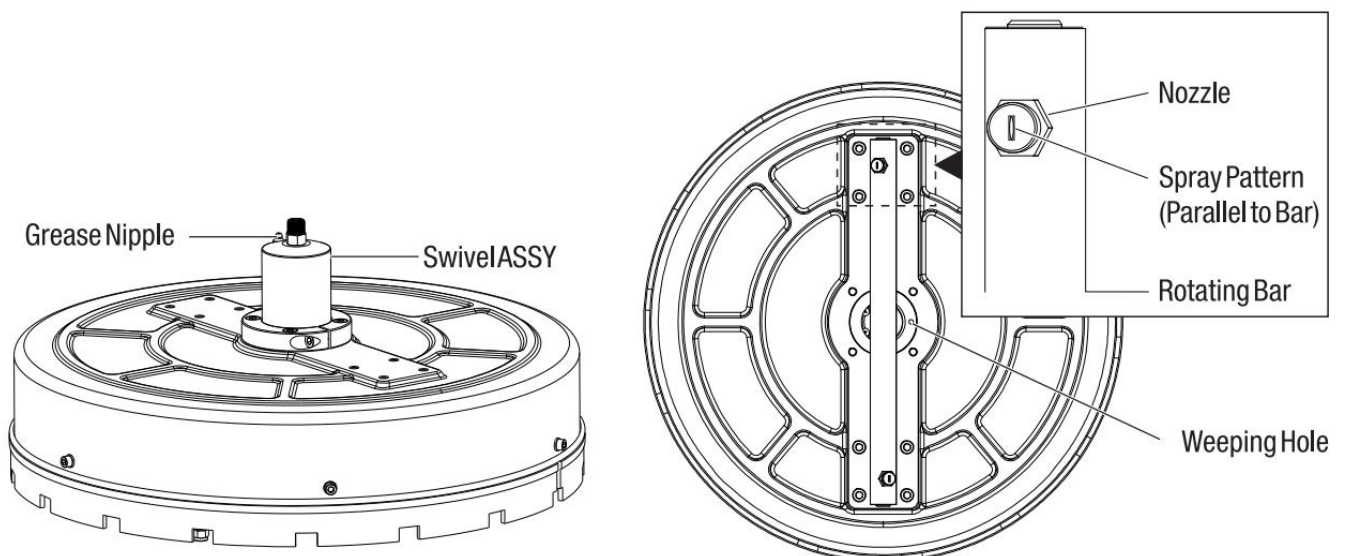

## 5. Parts Identification and Features (Continued)

### 5.3 Engine

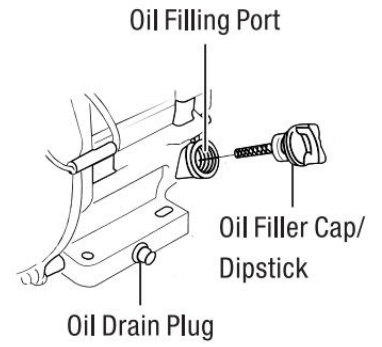
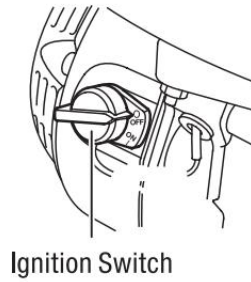
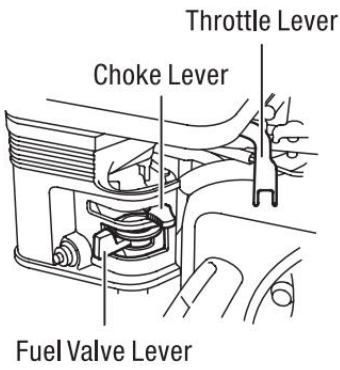
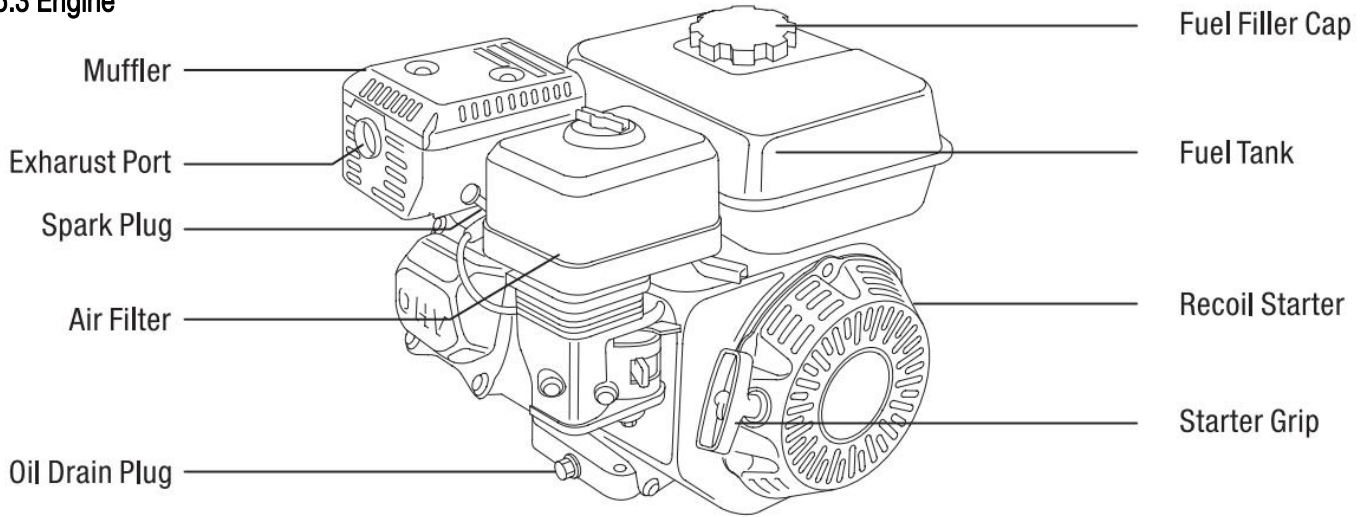

### 5.4 Standard Accessories

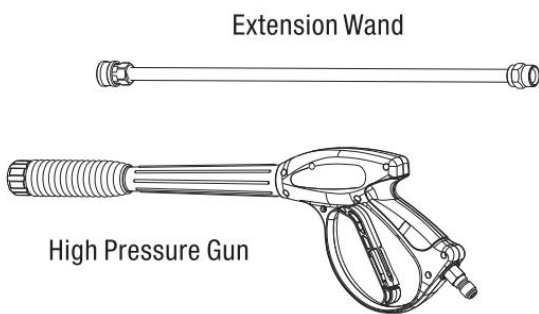

## 5. Parts Identification and Features (Continued)

### 5.1 General Technology

**PSI:** Pounds per square inch -common unit measure used for water pressure, air pressure, hydraulic pressure and pounds of force.

**GPM:** Gallons per minute (liters per minute [metric]) -common unit measure used for flow rate of water.

**Bypass Mode:** In bypass mode, high pressure pump recirculates water because spray gun trigger is not pulled.

### 5.2 High Pressure Washer Pump

1. Pump Model & Serial Number: It contains the year, month and day of production, and can track the batch of materials assembler and tester. Please provide the serial no. along with the pump model and version when ordering spare parts and reporting any issues of concern.
2. Pressure Adjusting Knob: To raising or reduce the pressure by turn the knob.
3. Detergent Injector: Use to siphon detergent or other pressure washer chemicals into the low pressure stream.
4. Water Outlet Connector: To connect high pressure hose.
5. Water Inlet With Filter Screen: Connect garden hose here, and always have the filter screen present in it.
6. Red Shipping Plug Attached With Vent Plug: the pump is ship with red shipping plug to prevent oil leaking during transportation. Replace with the attached vent plug before using.
7. Thermal Relief Valve: Cycles water through pump when water reaches 125-155 °F (50-68 °C). Warm water will discharge from pump onto ground. This valve can prevent internal pump damage.
8. High Pressure Turning Valve: This is a valve can discharges the air in the pump and water in-taking pipe line, enhance pump sucking ability, and allow to suck from the barrel and 1M deep.

### 5.3 Engine

1. Air Cleaner/Filter: Protects engine by filtering dust and debris out of intake air.
2. Fuel Tank: Fill tank with regular unleaded fuel. Always leave room for fuel expansion.
3. Throttle Lever: Sets engine in starting mode for recoil starter.
4. Choke Lever: Prepares a cold engine for starting.
5. Fuel Valve Lever: Used to turn fuel on and off to engine.
6. Recoil Starter: Use for starting the engine manually.
7. Ignition Switch: Set this switch to "On" before using recoil starter. Set switch to "Off" to switch off engine.
8. Oil Fill Cap: Fill engine with oil here.

### 5.4 Accessories

1. Extension wand: To attach the spray tips on it.
2. High Pressure Hose: Connect one end to the water pump and the other end to the spray gun.
3. Spray Gun: Controls the application of water onto cleaning surface with trigger device. Includes safety latch.
4. Spray Tips: 0/15/25/40 degree and soap nozzle for various high pressure cleaning applications.

## 6. Unpacking & Assembly

### 6.1 Unpacking

1. Carefully cut the box down the sides then remove the tool and any accessories from the box. Make sure than all items are included



#### CAUTION

Unit is heavy. Do not attempt to lift and remove the pressure washer unit from the carton.



2. Remove and discard the clear cap securing the operator's manual bag to the pump breather tube.
3. Inspect the tool carefully to make sure no breakage or damage occurred during shipping.
4. Do not discard the packing material unit you have carefully inspected satisfactorily operated the tool.
5. If any parts are damaged or missing, please contact with the dealer.

### 6.2 Assembly the Handle

1. Unscrew the Knob Bolt and Lift the handle up, alignment the hole, put through the Knob Bolt and fix with the nut.
2. **Put the Hose Reel Onto the Frame (If Applicable)**  
Pull the Locking Pin out, put the hose reel inside the base and place under the hooker, alignment the locking hole and put back the locking pin to lock the hose reel in place.

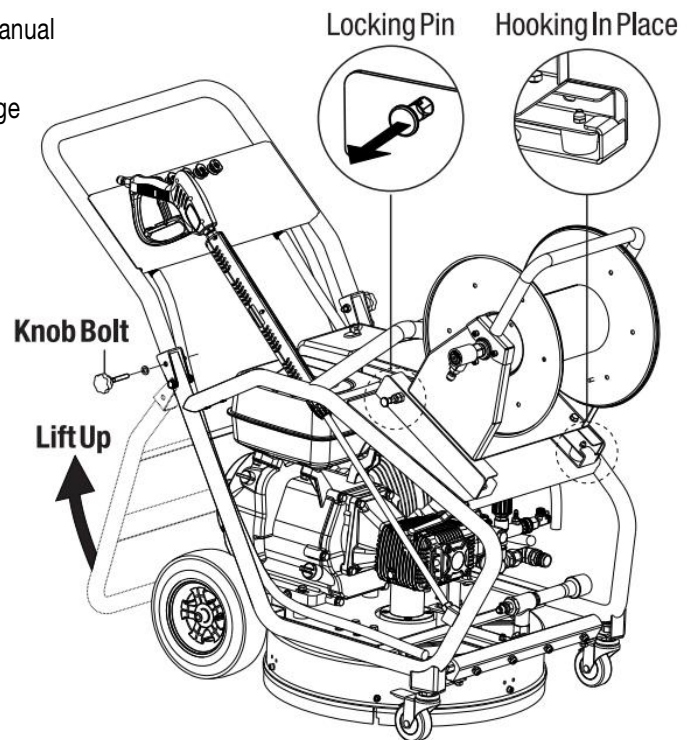

## 7. Setting Up Before Use

### 7.1 Adding Oil to Triplex Pump



#### WARNING

Operating the pump with low oil or no oil can cause permanent damage and VOIDS THE WARRANTY. Check the pump oil level to make sure it is correct.

1. Using an 17mm open-end wrench or socket wrench, remove shipping plug from pressure pump. Discard shipping plug.
2. Remove pump breather plug from parts bag and insert it into pressure pump.
3. Tighten pump breather plug securely by hand. Do not use open-end wrench or socket wrench to tighten.
4. Check the sight glass to ensure pump oil is at 1/2 of the sight glass level.
5. Add oil to pressure pump if level is below indicator on oil gauge.
6. Oil type API **SFSAE10W-30** or **15W/40**.
7. Change after the first 30 hours, then subsequently 100 hours.
8. We recommend the use high-quality **NON-DETERGENT** oils, if classified for service SF, SG, SH, SJ or higher. **DO NOT** use special additives. Outdoor temperatures determine the proper oil viscosity.

\*\* Below 40°F (4°C) the use of SAE 30 will result in hard starting.

\*\* Above 80°F (27°C) the use of 10W30 may cause increased oil consumption. Check oil level more frequently.

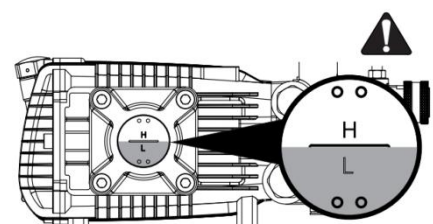
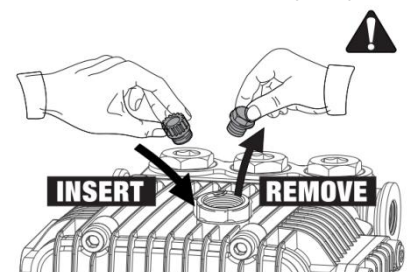

1/2 OIL LEVEL

## 7. Setting Up Before Use (Continued)

### 7.2 Add Oil To The Engine

1. Place pressure washer on a flat, level surface.
2. Clean area around oil fill and remove yellow oil fill cap.
3. Using oil funnel (optional), slowly pour contents of provided oil bottle into oil fill opening.
3. Replace oil fill cap and fully tighten.



#### NOTICE

Improper treatment of pressure washer can damage it and shorten its life.

**DO NOT attempt to crank or start the engine before it has been properly serviced with the recommended oil. This may result in an engine failure.**

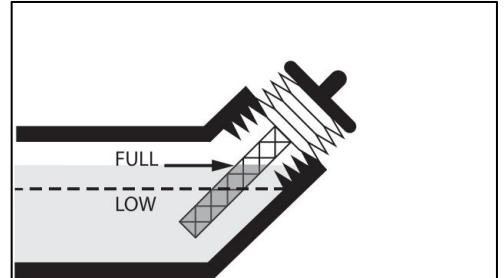
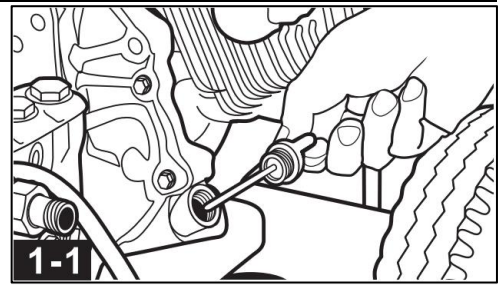

### 7.3 Add Fuel To the Engine



#### WARNING

Failure to use fuel as recommended in this manual will void the warranty.

**DO NOT** use unapproved gasoline such as E85 (85% ethanol/15% gasoline).

**DO NOT** mix oil with gasoline.

**DO NOT** modify engine to run on alternate fuels.

Mix in a fuel stabilizer when adding fuel to pressure washer to protect fuel system from forming gum deposits. If engine doesn't run properly after fueling, switch fuel brands. The engine is certified to run on gasoline. The emission control system for this engine is EM (Engine Modifications).

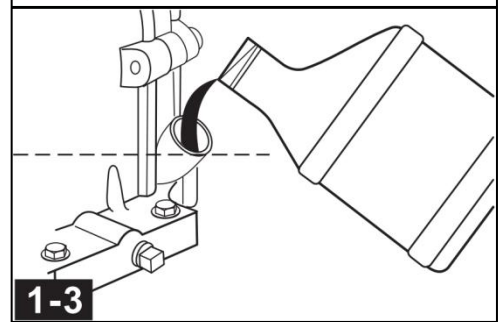

#### WARNING

Fuel and fuel vapor are extremely flammable and explosive. Fire or explosion from misuse of fuel can cause severe burns and even death.

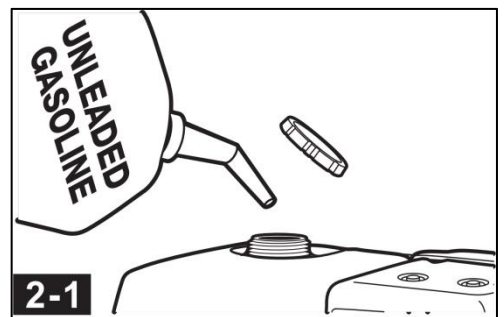

#### WHEN ADDING FUEL TO PRESSURE WASHER, OBSERVE THE FOLLOWING STEPS:

1. Turn pressure washer **OFF** and let it cool for at least two minutes before removing fuel cap. Loosen fuel cap slowly to release pressure.
2. Fill fuel tank outdoors.
3. **DO NOT** overfill fuel tank. Leave room for fuel to expand.
4. Wait for spilled fuel to evaporate before cranking engine.
5. Keep fuel away from sparks, open flames, pilot lights, heat and other ignition sources.
6. **DO NOT** light a cigarette or smoke near open fuel tank or container.
7. Clean area around fuel fill cap and slowly remove cap to allow any pressure to escape.
8. Slowly add unleaded gasoline **(A)** to fuel tank **(B)**. Use extreme caution not to fill fuel above baffle **(C)**. This allow appropriate space for fuel expansion.
9. Install fuel cap and allow any spilled fuel to evaporate before starting engine.

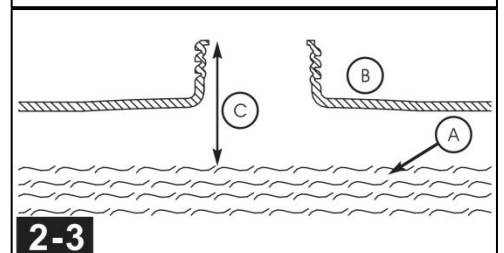
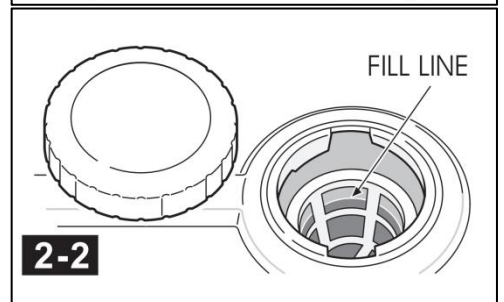

## 7. Setting Up Before Use (Continued)

### 7.4 Attaching High Pressure Hose to Spray Gun

1. Pull back the slip ring on quick-disconnect fitting of high pressure hose.
2. Insert quick-disconnect plug on spray gun into female quick-disconnect on high pressure hose
3. Release slip ring on female quick-disconnect and twist. Listen for **CLICK** to ensure both quick-disconnects are coupled.
4. Pull the hose and gun in opposite direction to ensure they do not separate.

### 7.5 Connecting Spray Wand to Spray Gun

1. Thread spray wand onto spray gun.

### 7.6 Attaching High Pressure Hose to Water Outlet Connector

1. Similarly, attach other end of high pressure hose to high pressure outlet on pump. Pull down on collar of quick connect, slide onto pump and let go of collar. Pull on hose to be sure of tight connection.

### 7.7 Turn On The Water Outlet Ball Valve

1. Hold the knob and turn 90 degree that alignment with outlet fitting.

### 7.8 Connect Hose and Water Supply to Pump

1. Similarly, attach other end of high pressure hose to high pressure outlet on pump. Pull down on collar of quick connect, slide onto pump and let go of collar. Pull on hose to be sure of tight connection.
2. Before connecting garden hose to water inlet, inspect inlet screen. Clean screen if it contains debris or have it replaced if damaged. **DO NOT** run pressure washer if inlet screen is damaged.
3. Run water through your garden hose for 30 seconds to clean out any debris.

**IMPORTANT: DO NOT siphon standing water for the water supply. Use ONLY cold water (less than 104°F/40°C).**

4. Connect the garden hose (not to exceed 50 feet in length and with the ID no less than 1/2") to the water inlet. Tighten by hand.
5. Turn **ON** the water, squeeze the trigger to purge the pump system of air and impurities.



### NOTICE

- **DO NOT** attempt to crank or start the engine before it has been properly serviced with the recommended oil. This may result in an engine failure.
- There **MUST** be at least ten feet (3 M) of unrestricted Garden hose between the pressure washer inlet and any device, such as a vacuum breaker or check valve.
- Damage to equipment resulting from failure to follow this instruction will **VOID WARRANTY**.

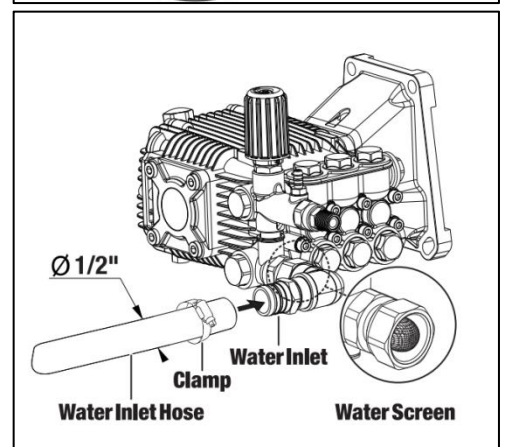
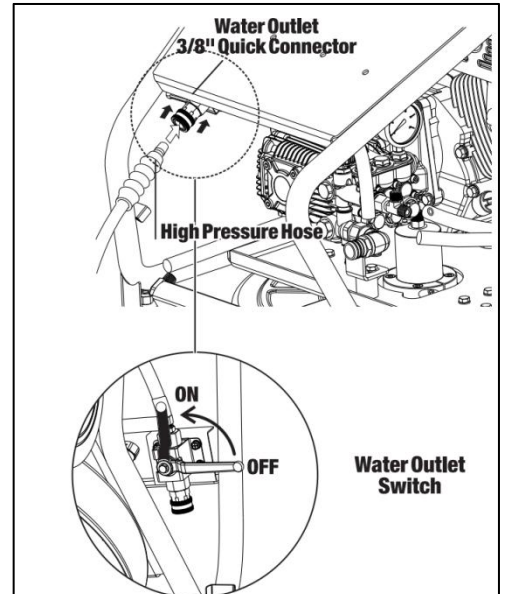
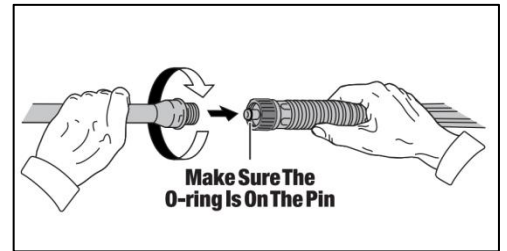
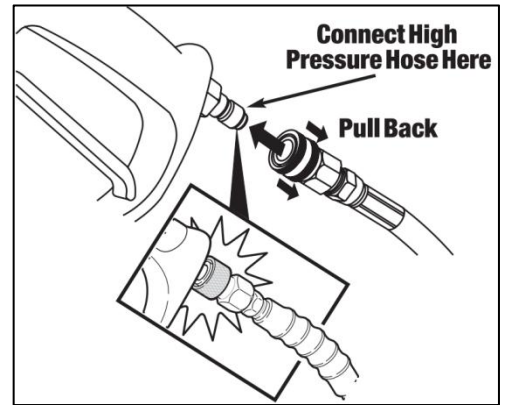

## 8. Safe Working Environment

### Pressure Washer Location

#### Clearances and Air Movement



### WARNING

- Exhaust heat/gases can ignite combustibles, structures or damage fuel tank causing a fire.  
Keep at least 5 ft. (1.5 m) clearance on all sides of pressure washer including overhead.



Place pressure washer in a well ventilated area, which will allow for removal of deadly exhaust gas. Do not place pressure washer where exhaust gas could accumulate and enter inside or be drawn into a potentially occupied building. Ensure exhaust gas (A) is kept away from any windows, doors, ventilation intakes, or other openings that can allow exhaust gas to collect in a confined area. Prevailing winds and air currents should be taken in



### WARNING



- Running engine gives off carbon monoxide, an odorless, colorless, poison gas.
- Breathing carbon monoxide can cause headache, fatigue, dizziness, vomiting, confusion, seizures, nausea, fainting or death.  
Operate pressure washer ONLY outdoors.  
Keep exhaust gas from entering a confined area through windows, doors, ventilation intakes, or other openings.  
DO NOT start or run engine indoors or in an enclosed area, even if windows and doors are open

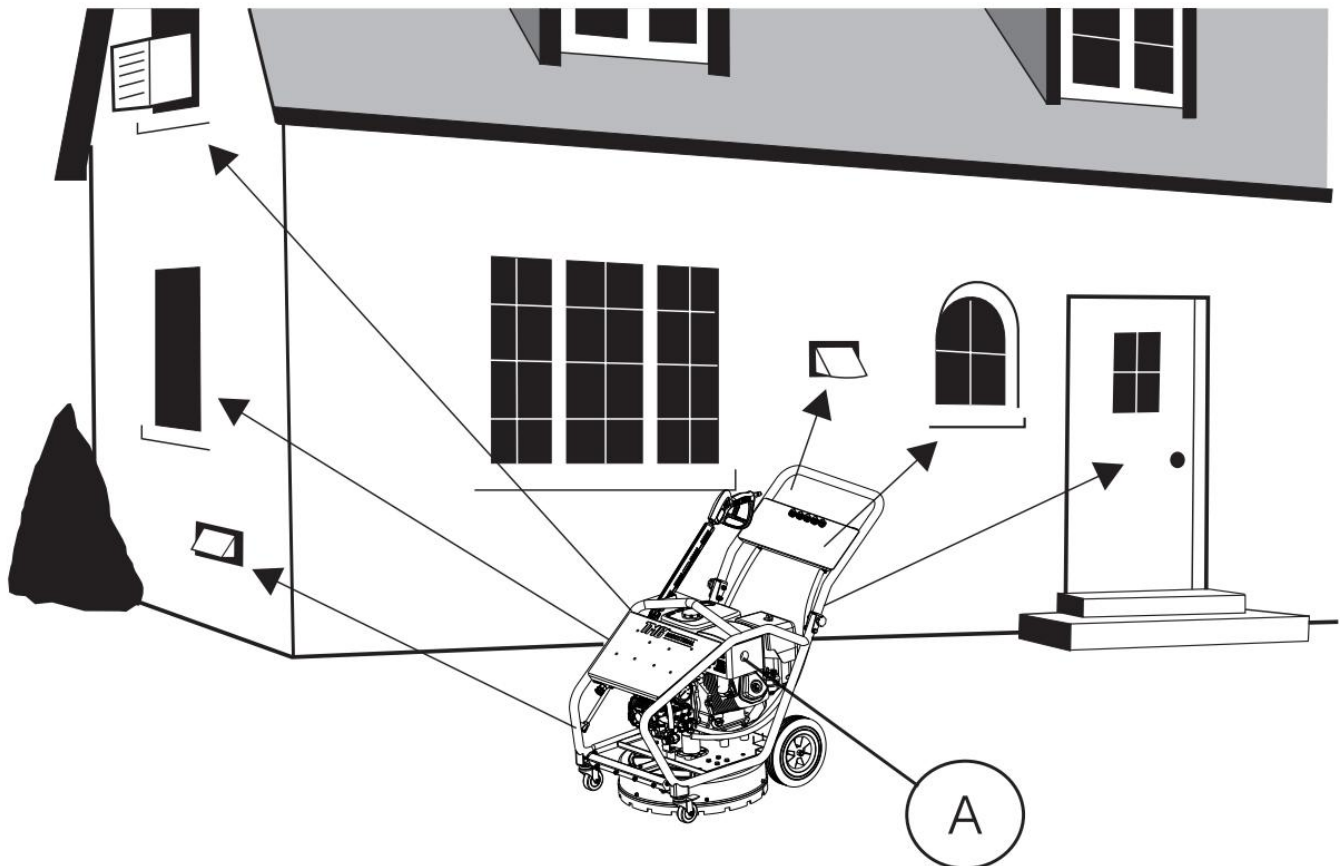

## 9. Startup Procedure



### WARNING

- RISK OF EYE INJURY.  
Spray can splash back or propel objects.

- Always wear safety goggles when using this equipment or in vicinity of where equipment is in use.
- Before starting the pressure washer, be sure you are wearing adequate safety goggles.
- NEVER substitute safety glasses for safety goggles

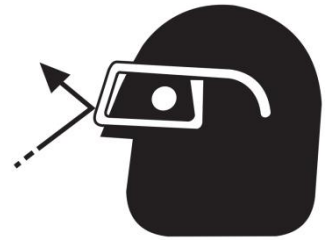

### 9.1 How to Start Your Pressure Washer

To start your pressure washer for the first time, follow these instructions step-by-step. This starting information also applies if you have let the pressure washer sit idle for at least a day.

1. Place pressure washer near an outside water source capable of supplying water at a flow rate at least 5GPM/19LPM and no less than 20PSI/1.3BAR at pressure washer end of garden hose.
2. Check that high pressure hose is tightly connected to spray gun and pump.
3. Make sure unit is in a level position.
4. Uncoil high pressure hose completely before using pressure washer.
5. Connect garden hose to water inlet on pressure washer pump.
6. Turn ON water, point gun in a safe direction and squeeze trigger to purge pump system of air and impurities.
7. Attach wand to spray gun. Tighten by hand.
8. Choose the nozzle you want to use, pull back on collar of quick connector, insert nozzle and release collar. Tug on nozzle to make sure it is securely in place.
9. Rotate fuel shut-off valve to " OPEN " position.
10. Move throttle control lever 1/3 toward " FAST " Position.
11. Move choke lever to " CHOKE " position.

**NOTE:** For a warm engine, be sure the choke lever is in the " RUN " position.

**IMPORTANT:** Before starting the pressure washer, be sure you are wearing adequate safety goggles.

12. When starting engine, position yourself as recommended below and grasp starter grip handle and pull slowly until you feel some resistance. Then pull rapidly to start engine.
13. Return starter grip handle slowly. **DO NOT** let rope "snap back" against starter.
14. When engine starts, slowly move choke lever to " RUN " position, as engine warms. If engine falters, move choke lever to " CHOKE " position, then to " RUN " position.
15. After each starting attempt, where engine fails to run, always point gun in safe direction and squeeze spray gun trigger to release high pressure.
16. If engine fails to start after six pulls, move choke lever to " RUN " position, and repeat steps 13 through 15.

**IMPORTANT:** Allow the Engine to run at no load, low pressure for five minutes after each start-up so Engine can stabilize.

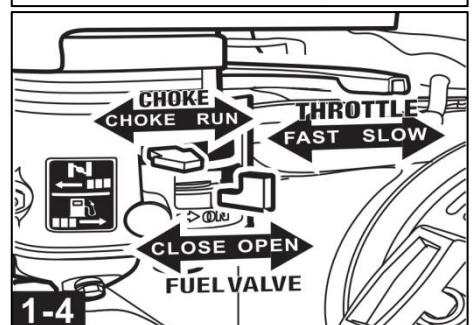
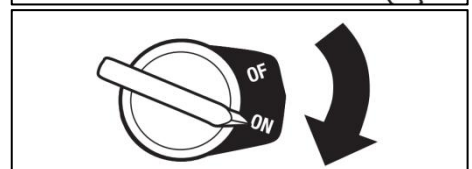
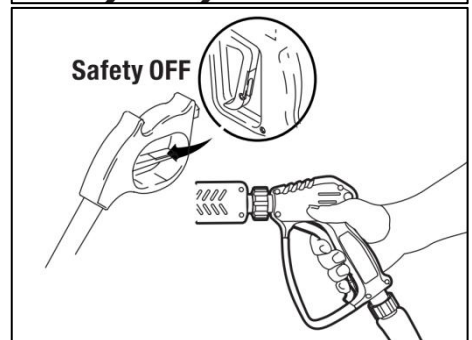
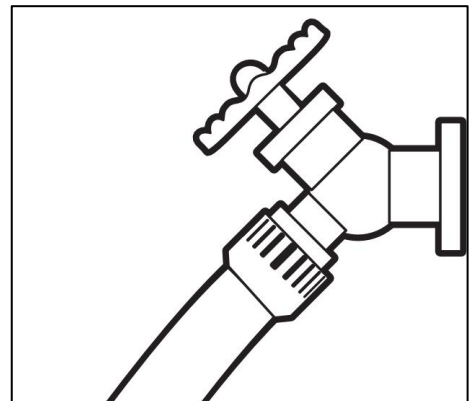



## 10. Operation

### 1. Washing With Water Broom

1. Ensure all connections are secure. Turn the water supply completely "ON".  
(DO NOT START PRES-SURE WASHER!)
2. Turn the Water Broom Switch ON, water will begin flowing from the nozzles of the Surface Cleaner. Ensure nozzles are not clogged and spray pattern is not erratic. Change nozzles before proceeding if problems exist.
3. Turn the other Water Outlet and Surface Cleaner Switch OFF..
4. Start the pressure washer follow the starting procedure.
5. Walk slowly behind the pressure washer, cleaning as you go.

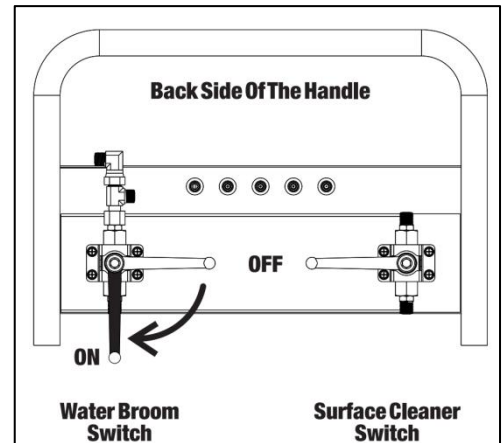

### 2. Washing With Surface Cleaner

1. Clear any loose debris from the area to be cleaned.
2. Ensure all connections are secure. Turn the water supply completely "ON".  
(DO NOT START PRES-SURE WASHER!)
3. Turn the Surface Cleaner Switch ON, water will begin flowing from the nozzles of the Surface Cleaner. Ensure nozzles are not clogged and spray pattern is not erratic. Change nozzles before proceeding if problems exist.
4. Turn the other Water Outlet and Water Broom Switch OFF..
5. Start the pressure washer follow the starting procedure.
6. Walk slowly behind the pressure washer, cleaning as you go.

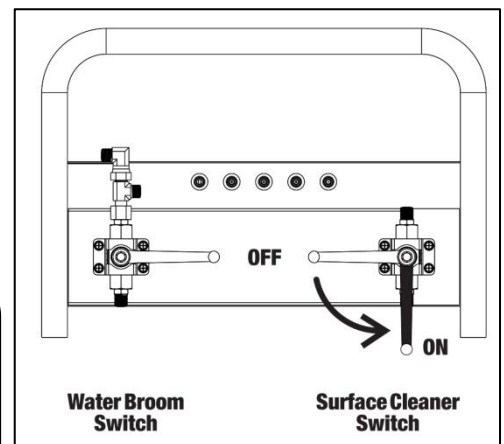

### NOTICE

Never attempt to clean surface with objects that protrude from the surface being cleaned. Striking any raised obstacle during operation will damage machine. If contact does occur and results in vibration when operating machine, STOP and replace spray bar.

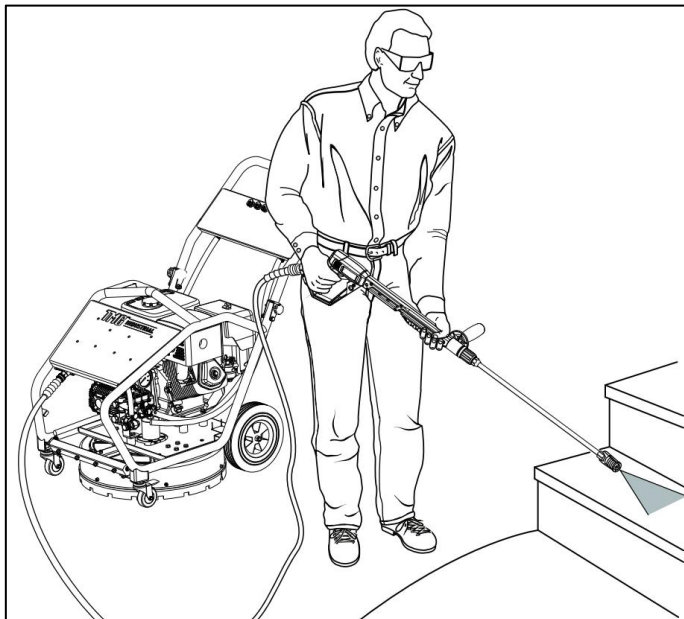

1. Spray Gun Operation

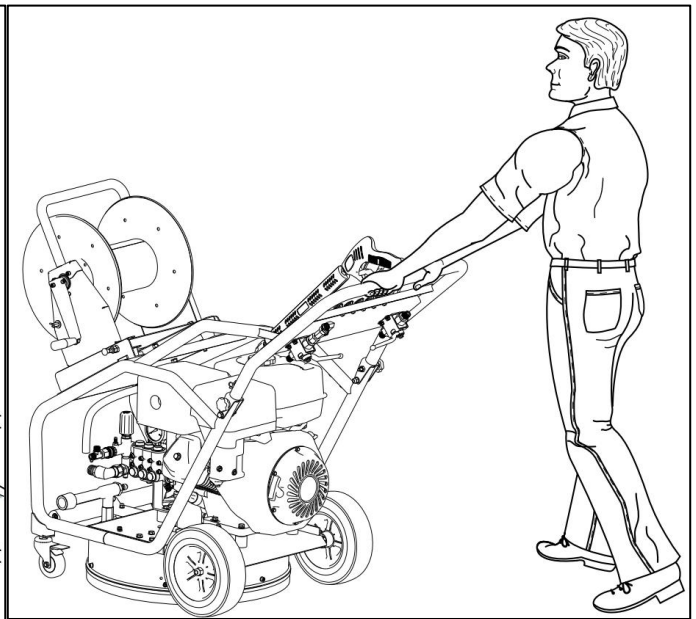

2. Water Broom or Rotating Washing Operation

# 11. Stopping the Pressure Washer

## How to Stop Your Pressure Washer

1. To stop the engine using the ON/OFF switch: Turn the Ignition switch to OFF, close the fuel valve.
2. To stop the engine using the Fuel Valve: Close the Fuel Valve and wait for the engine to stop.

**NOTE:** Avoid letting fuel remain in the carburetor for lone periods as this can clog carburetor passages with impurities resulting in malfunctions.

3. **ALWAYS** point spray gun in a safe direction, press red button and squeeze trigger to release retained high water pressure.

**IMPORTANT:** Spray gun traps high water pressure, even when engine is stopped and water is disconnected.

# 12. Using Nozzles

## 12.1 Attaching Pressure Nozzles to Spray Wand

1. Engage trigger lock on spray gun.
2. Pull slip ring on female quick-disconnect fitting of spray wand back.
3. Insert nozzle into female quick-disconnect socket on spray wand.
4. Release slip ring on female quick-disconnect and twist. Listen for "lick" to ensure both quick-disconnects are coupled.
4. Pull high pressure nozzle and spray wand in opposite direction to ensure they do not separate.

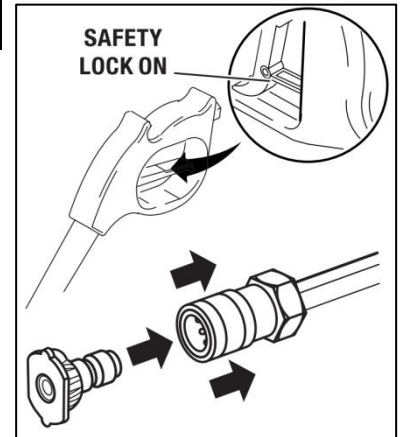

## 12.2 Nozzle Size Guide

The pressure washer comes with five spray nozzles. Each nozzle is color coded and delivers a specific spray pattern and pressure for a particular cleaning job. The size of the nozzle determines the size of the fan spray and the pressure out of the nozzle.

The are stored in receptacles on a panel mounted to the handle of the washer. Colors on the panel identify nozzle location and spray panel.

### **WARNING**

- Pressure washer produces fluid pressures and velocities high enough to penetrate human and animal flesh which could result in serious injury or amputation.
- Do not point pressure washer in direction of people or animals.
- High velocity fluid spray can cause objects to break, propelling particles at high speeds..

**0° Nozzle - Red:** This nozzle delivers a pinpoint stream of pressurized water and is extremely powerful. It covers only a small area of cleaning. This nozzle should only be directed at surfaces that can withstand high pressure such as metal or concrete. Do not use this nozzle to clean wood.

**15° Nozzle - Yellow:** This nozzle delivers a powerful 15 degree spray pattern for intense cleaning of small areas. This nozzle should only be used on areas and materials that can withstand high pressure.

**25° Nozzle - Green:** This nozzle delivers a 25 degree spray pattern for intense cleaning of larger areas. This nozzle should only be used on areas that can withstand pressure from this nozzle.

**40° Nozzle - White:** This nozzle delivers a 40 degree spray pattern and a less powerful stream of water. This nozzle can cover a wide area and should be used for most general cleaning jobs.

**Chemical Nozzle - Black:** This nozzle is used to apply special chemicals and cleaning solutions. This nozzle produces the weakest pressure stream of the five nozzles.

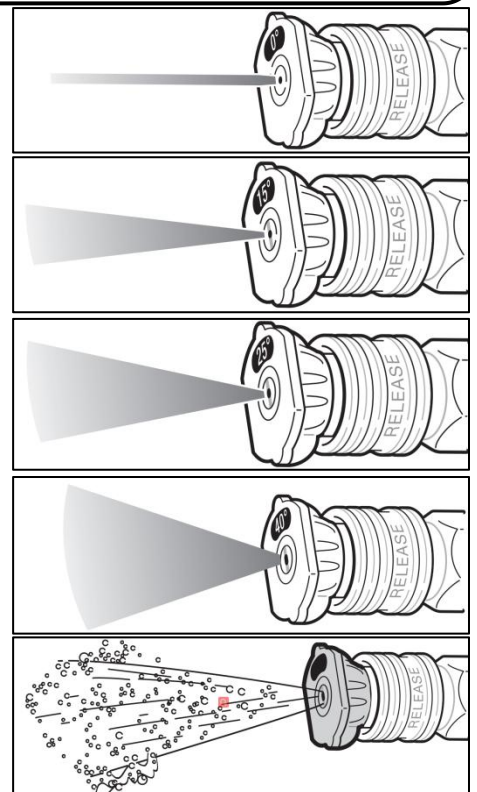

## 13. Adjusting Spray Pressure

### Pressure Rinsing

1. Remove black spray tip from nozzle extension.
2. Select and install desired high pressure spray tip.
3. Keep spray gun a safe distance from area you plan to spray.
4. Increase (decrease) spray pressure by turning pressure control knob clockwise (counterclockwise).
5. Apply a high pressure spray to a small area and then check surface for damage. If no damage is found, you can assume it is okay to continue rinsing.
6. Start at top of area to be rinsed, working down with same overlapping strokes as you used for cleaning.

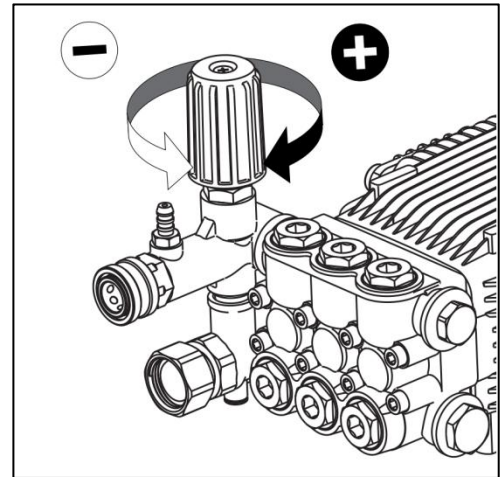

## 14. Using Chemicals & Detergents

**NOTE:** Use only detergents designed for pressure washers; household detergents, acids, alkalines, bleaches, solvents, flammable material, or industrial grade solutions can damage the pump. Many detergents may require mixing prior to use. Prepare cleaning solution as instructed on the solution bottle.

### 14.1 Set Up Procedure:

1. Attach the chemical hose onto the barbed fitting situated near the back of the high pressure hose connection.
2. Press the other end of the chemical hose (with the filter attached) into the container holding the chemicals or detergents you are using.
3. Attach the chemical nozzle onto the lance as shown previously.

### 14.2 Chemical Cleaning

1. Spray the chemicals onto a dry surface using the procedures outlined in previous sections. Start at the lower portion of the cleaning area and working upwards, using long, even, overlapping strokes.
2. Always ensure that the filter is fully submerged in the cleaning solution at all times.
3. Allow the detergent to soak in for 3-5 minutes before washing and rinsing.
4. Re-apply as needed to prevent the surface from drying. Do not allow the detergent to dry on to the cleaning surface to prevent streaking.

**NOTE:** Detergent cannot be applied with the high pressure spray tips (white, green, yellow or red)

### 14.3 After Chemical Cleaning

**IMPORTANT:** You will need to flush the detergent siphoning system after each use by placing the filter into a bucket of clean water then run the pressure washer in low pressure for 1 -2 minutes.

1. After using chemicals, soaps and detergents it is necessary to thoroughly clean the pressure washer.
2. Place the chemical hose in a container of clean water.
3. Turn on the pressure washer and hold the trigger on the spray gun top draw clean water through the system to clean it thoroughly.

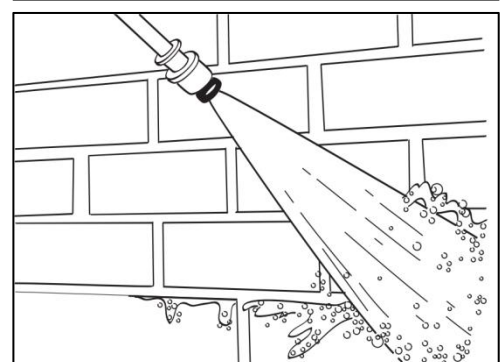
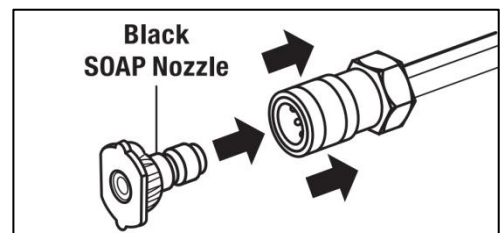
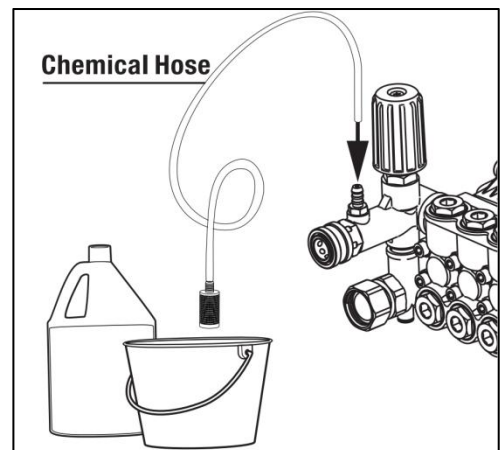

## 15. Maintenance

To ensure efficient operation and longer life of your pressure washer a routine maintenance schedule should be prepared and followed. If the equipment is used in unusual conditions such as high-temperature or dusty conditions more frequent maintenance checks will be required.



### WARNING

Before performing any maintenance be aware that the equipment should be completely shutdown, depressurized and allowed to cool down. This will ensure that no injuries can be sustained by moving parts, water pressure or hot surfaces.

**Engine contains flammable fuel do not smoke near or work near naked flames while maintaining this equipment. Please note: All repairs should be carried out by Dealer approved engineers. All replacement parts should be supplied or recommended by the Dealer. Any unapproved repairs or modifications will invalidate the warranty.**

### 15.1 Engine:

Check the engine regularly, replace oil, clean spark plugs and maintain parts as required.

### 15.2 Pump Oil:

Change the pump oil regularly. Change the pump oil after the first 50 hours of work and successively every 200 hours.

In either case ensure that the oil is changed at least once a year. Check with your nearest Dealer for advice on the best Pump Oil to use with this equipment if you are unsure.



### NOTICE

**Avoid prolonged or repeated skin contact with used motor oil.**

Used motor oil has been shown to cause skin cancer in certain laboratory animals. Thoroughly wash exposed areas with soap and water.



**KEEP OUT OF REACH OF CHILDREN. DON'T POLLUTE. CONSERVE RESOURCES. RETURN USED OIL TO COLLECTION CENTERS.**

### 15.3 Nozzle Unclogging:

If the nozzle becomes clogged with dirt and debris excessive pressure can build up. If the nozzle becomes partially clogged or restricted the pump pressure will fluctuate and can become harmful and dangerous.

Clean the nozzle immediately and follow these instructions:

1. Shut-off the engine and turn off / disconnect the water supply.
2. Pull the trigger on the gun to relieve any water pressure.
3. Disconnect the lance from the gun.
4. Remove the nozzle from the lance - remove any obstructions with the nozzle cleaning tool and back flush with clean water.
5. Direct the water supply into the spray wand end to back flush loosened particles for 30 seconds.
6. Reassemble the nozzle onto the lance.
7. Reconnect the lance to the gun and turn on the water supply.
8. Start the washer pump and place the lance into the high pressure setting to test.

#### Nozzle Cleaning Pin

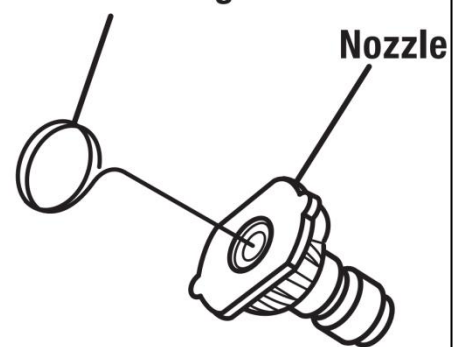

### 15.4 Cleaning The Water Filter:

The water filter should be checked regularly and cleaned if necessary:

1. Remove the filter by grasping the end and removing it from the water inlet on the pump.
2. Clean the filter by flushing it with water on both sides.
3. Re-insert the filter in the water inlet on the pump.

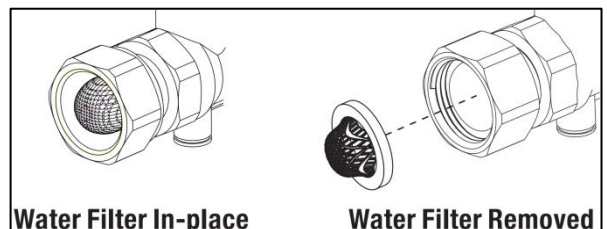

## 15. Maintenance (Continued)

### 15.5 High Pressure Hose:

Replace the high pressure hose when the hose have any of the below circumstance:

1. Cover damaged.
2. Burst.
3. Bubbles/blisters.
4. Kinked/collapsed.

#### **WARNING**



The high pressure stream of water can cut through skin and its underlying tissues, leading to serious injury and possible amputation.

- Never repair high pressure hose. Replace it.
- Replacement hose rating MUST exceed maximum pressure rating of the unit

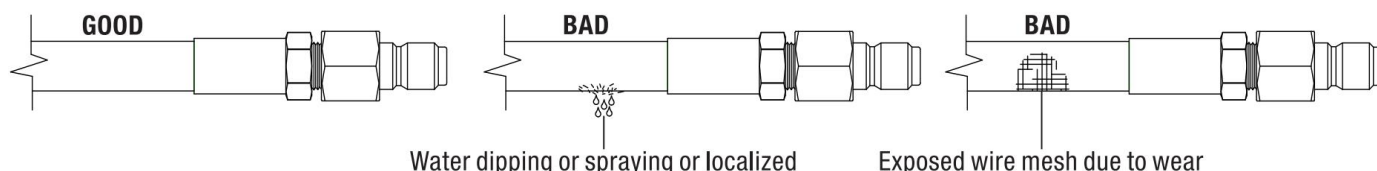

**NOTE: BE CAREFUL** with high pressure hose against sharp edges Sharp edges can scrap, slice and generally damage hose quickly. While hose is easily replaced, it pays to take care by buffering sharp edges with tape, cardboard, etc., to maximize its useful life.

### 15.6 Cleaning the Fuel Tank Filter:

The fuel tank filter should be removed and cleaned after every 150 hours of running or every 3 months using an environmentally -friendly water-based de-greasing agent. Refit when clean.

### 15.7 Maintenance Schedule

Item	Task Description	Each Use	1st Month (20Hrs)	Frequency Each Season (50Hrs)	Every 6 MONTHS (100Hrs)	Every YEAR (300Hrs)
Engine Oil	Oil Level Check	•				
	Replace		•		•	
Reduction Gear Oil (If applicable)	Oil Level Check	•				
	Replace		•		•	
Air Cleaner/filter	Check	•				
	Clean			,X	•X	
	Replace					•
Deposit Cup	Clean				•	
Spark Plug	Clean.Adjust				•	
	Replace					•
Spark Eliminator	Clean				•	
Idling	Check.Adjust					•
Valve Clearance	Check,Adjust					
Fuel Tank&Filter	Clean					
Fuel Supply Line	Check	Check with your Dealer for advice if any problem are detected				

#### Key:

\* = Only for inside ventilating double core carburetors

\*\* = Only for paper core cleaners

x = Repeat task more often than scheduled if equipment is used in dusty working environments

△ = Maintenance to be carried out by Dealer approved technician

## 16. Storage

### 1. After General / Regular Use

1. When completing pass through drain, watch for tape marker on hose as you pull the hose out.
2. Reduce pressure gradually with pressure regulator knob until pressure gauge is at zero.
3. Stop the washer engine
4. Continue to run water through pump and hose for 30 to 60 seconds.
5. Close water faucet and disconnect garden hose from spigot.
6. Close water inlet valve. Disconnect garden hose from washer.
7. Remove nozzle if you chose.
8. Store high pressure hose properly on reel or in a coil to avoid damage to hose.

### 2. Preparation for Winter and Long-term Storage

Note: It is recommended that you follow these steps to protect the internal seals of the pump when storing the equipment for more than 30 days and or when, freezing temperatures are expected.

1. Obtain a funnel, 200ml of antifreeze and approximately 1M of garden hose with a male hose connector attached to one end.
2. Disconnect the spark plug wire.
3. Connect the hose to water inlet on the pump.
4. Pour the antifreeze into the hose via the funnel.
5. Pull the engine starter cord slowly several times until antifreeze comes out of the high pressure water hose connection on the pump.
6. Remove the short hose from the water inlet on the pump.
7. Reconnect the spark plug wire.

### 3 Service After Storage

Before reusing the equipment after storage, you should carry out the following to keep the equipment in good condition.

Storage Time	Service Tank
Within one month	No service required
One-two months	Drain out the existing fuel out of the fuel tank and fresh fuel
Two months - one year	Drain out the existing fuel out of the fuel tank and fresh fuel Drain the fuel out of carburetor Empty the deposit cup
Over a year	Drain out the existing fuel out of the fuel tank and fresh fuel Drain the fuel out of carburetor Empty the deposit cup Close the FUEL VALVE and wait engine to stop

#### Key:

\* = Unscrew the drain plug and drain out the fuel in the carburetor

\*\* = Turn engine switch to the off position, disconnect the deposit cup and empty contents safely

**Note:** Do not dump oil vessels or discarded engine oil onto the ground. Take all discarded engine oil in a closed container to your nearest recycling station.

## 17. Troubleshooting

PROBLEM	PROBABLE CAUSE	SOLUTION
<b>Engine shuts down when running.</b>	<ol style="list-style-type: none"> <li>1. Out of fuel.</li> <li>2. Low Engine Oil</li> </ol>	<ol style="list-style-type: none"> <li>1. Fill fuel tank.</li> <li>2. Add oil.</li> </ol>
<b>Engine will not start; or starts and runs rough.</b>	<ol style="list-style-type: none"> <li>1. Rocker switch set to "OFF" position.</li> <li>2. Fuel valve is in "OFF" position.</li> <li>3. Dirty air cleaner</li> <li>4. Out of fuel.</li> <li>5. Stale fuel</li> <li>6. Spark plug wire not connected to spark plug.</li> <li>7. Bad spark plug.</li> <li>8. Water in fuel</li> <li>9. Flooded.</li> <li>10. Excessively rich fuel/air mixture.</li> <li>11. In take valve stuck open or closed.</li> <li>12. Engine has lost compression.</li> <li>13. Low engine oil.</li> <li>14. Wrong Fuel.</li> <li>15. Engine is too hot.</li> <li>16. Chock is in wrong position.</li> </ol>	<ol style="list-style-type: none"> <li>1. Set switch to "ON" position.</li> <li>2. Turn fuel valve to "ON" position.</li> <li>3. Clean or replace air cleaner</li> <li>4. Fill fuel tank.</li> <li>5. Drain fuel tank and carburetor; fill with fresh fuel.</li> <li>6. Connect wire to spark plug.</li> <li>7. Replace spark plug.</li> <li>8. Drain fuel tank and carburetor; fill with fresh fuel.</li> <li>9. Wait 5 minutes and re-crank engine.</li> <li>10. Contact authorized service facility.</li> <li>11. Contact authorized service facility.</li> <li>12. Contact authorized service facility.</li> <li>13. Add oil</li> <li>14. Use recommended fuel.</li> <li>15. Allow engine to cool.</li> <li>16. Change chock position.</li> </ol>
<b>Engine "Hunts" or falters.</b>	<ol style="list-style-type: none"> <li>1. Carburetor is running too rich or too lean.</li> </ol>	<ol style="list-style-type: none"> <li>1. .Contact authorized service facility.</li> </ol>
<b>Engine lacks power.</b>	<ol style="list-style-type: none"> <li>1. Cylinder pressure is low.</li> <li>2. Dirty air cleaner</li> </ol>	<ol style="list-style-type: none"> <li>1. Contact authorized service facility.</li> <li>2. Replace air filter.</li> </ol>
<b>No pressure or Low pressure.</b>	<ol style="list-style-type: none"> <li>1. The cock on the hose reel in OFF position.</li> <li>2. Lower water supply.</li> <li>3. Hose fitting leaks during high pressure.</li> <li>4. Nozzle obstructed.</li> <li>5. Water filter screen obstructed.</li> <li>6. Defective thermal relief valve.</li> <li>7. Air in hose.</li> <li>8. Choke lever in choke position.</li> <li>9. Throttle control lever is hot in fast position.</li> <li>10. High pressure jetting hose is too long.</li> <li>11. Pressure regulator wide open</li> </ol>	<ol style="list-style-type: none"> <li>1. Turn on the cock.</li> <li>2. Water simply must be 5 GPM @ 20 psi.</li> <li>3. Tighten hose fitting. Use thread sealant tape if necessary.</li> <li>4. Replace the nozzle</li> <li>5. Remove and clean filter.</li> <li>6. Call Customer Service:</li> <li>7. Stop engine and water source. Disconnect water source from pump inlet and turn water source to ON to remove all air from hose. When steady stream of water is present, turn water source to OFF. Re-connect water source to pump inlet and turn on water source, turn on the reel cock to remove remaining air.</li> <li>8. Move choke to NO CHOKE position.</li> <li>9. Move throttle control lever from fast position.</li> <li>10. Use the right size and length of the hose.</li> <li>11. Turn the regulator to increase pressure.</li> </ol>

## 17. Troubleshooting (Continued)

PROBLEM	PROBABLE CAUSE	SOLUTION
<b>No Water Flow.</b>	<ol style="list-style-type: none"> <li>1. Kinked or collapsed garden hose.</li> <li>2. Water supply not turned on.</li> <li>3. Clogged nozzle.</li> <li>4. The hose reel cock in OFF position.</li> </ol>	<ol style="list-style-type: none"> <li>1. Remove kink or replace worn hose.</li> <li>2. Turn water supply on.</li> <li>3. Remove nozzle &amp; clean orifices.</li> <li>4. Make sure valves are open.</li> </ol>
<b>No or low pressure (after period of normal use).</b>	<ol style="list-style-type: none"> <li>1. Worn seal or packing.</li> <li>2. Worn or obstructed valves.</li> <li>3. Worn unloader piston.</li> <li>4. Worn E-Z start valve.</li> </ol>	Have parts cleaned or replaced by authorized dealer.
<b>Water in crankcase.</b>	<ol style="list-style-type: none"> <li>1. Humid air condensing into water in crankcase.</li> <li>2. Worn packing and/or plunger.</li> <li>3. Water retaining ring on plunger worn.</li> </ol>	<ol style="list-style-type: none"> <li>1. Change oil. Use only high grade automotive 30 weight non detergent oil.</li> <li>2. Replace packing.</li> <li>3. Replace O-rings.</li> </ol>
<b>Water leaking at pump.</b>	<ol style="list-style-type: none"> <li>1. Loose connections.</li> <li>2. Piston packings worn.</li> <li>3. Worn or broken O-rings.</li> <li>4. Pump head or tubes damaged from freezing.</li> </ol>	<ol style="list-style-type: none"> <li>1. Tighten connections.</li> <li>2. Have parts cleaned or replaced by authorized dealer.</li> <li>3. Have parts cleaned or replaced by authorized dealer.</li> <li>4. Have parts cleaned or replaced by authorized dealer.</li> </ol>
<b>Oil leaking at pump</b>	<ol style="list-style-type: none"> <li>1. Oil seals worn.</li> <li>2. Loose drain plug.</li> <li>3. Worn drain plug O-ring.</li> <li>4. Worn fill plug O-ring.</li> <li>5. Pump overfilled.</li> <li>6. Incorrect oil used.</li> <li>7. Vent plug clogged.</li> </ol>	<ol style="list-style-type: none"> <li>1. Have parts cleaned or replaced by authorized dealer.</li> <li>2. Tighten drain plug.</li> <li>3. Inspect and replace O-ring.</li> <li>4. Inspect and replace O-ring.</li> <li>5. Check for correct amount.</li> <li>6. Drain and refill with correct type and amount of oil.</li> <li>7. Clean vent plug. Use air hose to free it of blockage. If problem persists, replace vent plug.</li> </ol>
<b>Pump pulsates</b>	<ol style="list-style-type: none"> <li>1. Nozzle obstructed.</li> </ol>	<ol style="list-style-type: none"> <li>1. See "Using Spray Wand" section.</li> </ol>



## 17. Troubleshooting (Continued)

PROBLEM	PROBABLE CAUSE	SOLUTION
<b>Rotating Bar Will Not Rotate</b>	<ol style="list-style-type: none"> <li>1. Seal has drag.</li> <li>2. Snap ring dislodged.</li> <li>3. Seal malfunction.</li> <li>4. Bearing failure.</li> </ol>	<ol style="list-style-type: none"> <li>1. Allow for break-in period.</li> <li>2. Do not use! Contact your customer service.</li> <li>3. Do not use! Contact your customer service.</li> <li>4. Do not use! Contact your customer service.</li> </ol>
<b>Excessive Vibration of Surface Cleaner or Cleaner Base Is Creating A Suction To The Surface</b>	<ol style="list-style-type: none"> <li>1. Nozzle clogged.</li> <li>2. Rotating bar, bolts or fittings loose.</li> <li>3. Rotating bar or swivel rotor bent.</li> </ol>	<ol style="list-style-type: none"> <li>1. Clean or replace.</li> <li>2. Tighten.</li> <li>3. Replace.</li> </ol>
<b>Streaked Cleaning Pattern</b>	<ol style="list-style-type: none"> <li>1. Insufficient water supply OR PSI of pressure washer is too low. (Won't allow Rotating Bar to move.)</li> <li>2. Nozzle clogged.</li> <li>3. Cleaning too fast.</li> </ol>	<ol style="list-style-type: none"> <li>1. Increase water supply or ensure pressure is a minimum of 2000 PSI and GPM is a minimum of 2.4</li> <li>2. Clean or replace.</li> <li>3. Slow down pace.</li> </ol>
<b>Water Weeping From Swivel water</b>	<ol style="list-style-type: none"> <li>1. mall amount of seepage is normal.</li> </ol>	<ol style="list-style-type: none"> <li>1. No modification is necessary.</li> </ol>
<b>Shooting From Swivel</b>	<ol style="list-style-type: none"> <li>1. Seal malfunction.</li> </ol>	<ol style="list-style-type: none"> <li>1. Replace.</li> </ol>
<b>Rotating Nozzle Arm Not Spinning, Bearing Noise</b>	<ol style="list-style-type: none"> <li>1. Bearing low on grease.</li> </ol>	<ol style="list-style-type: none"> <li>1. Grease bearing.</li> </ol>

# 18. Exploded View & Parts List

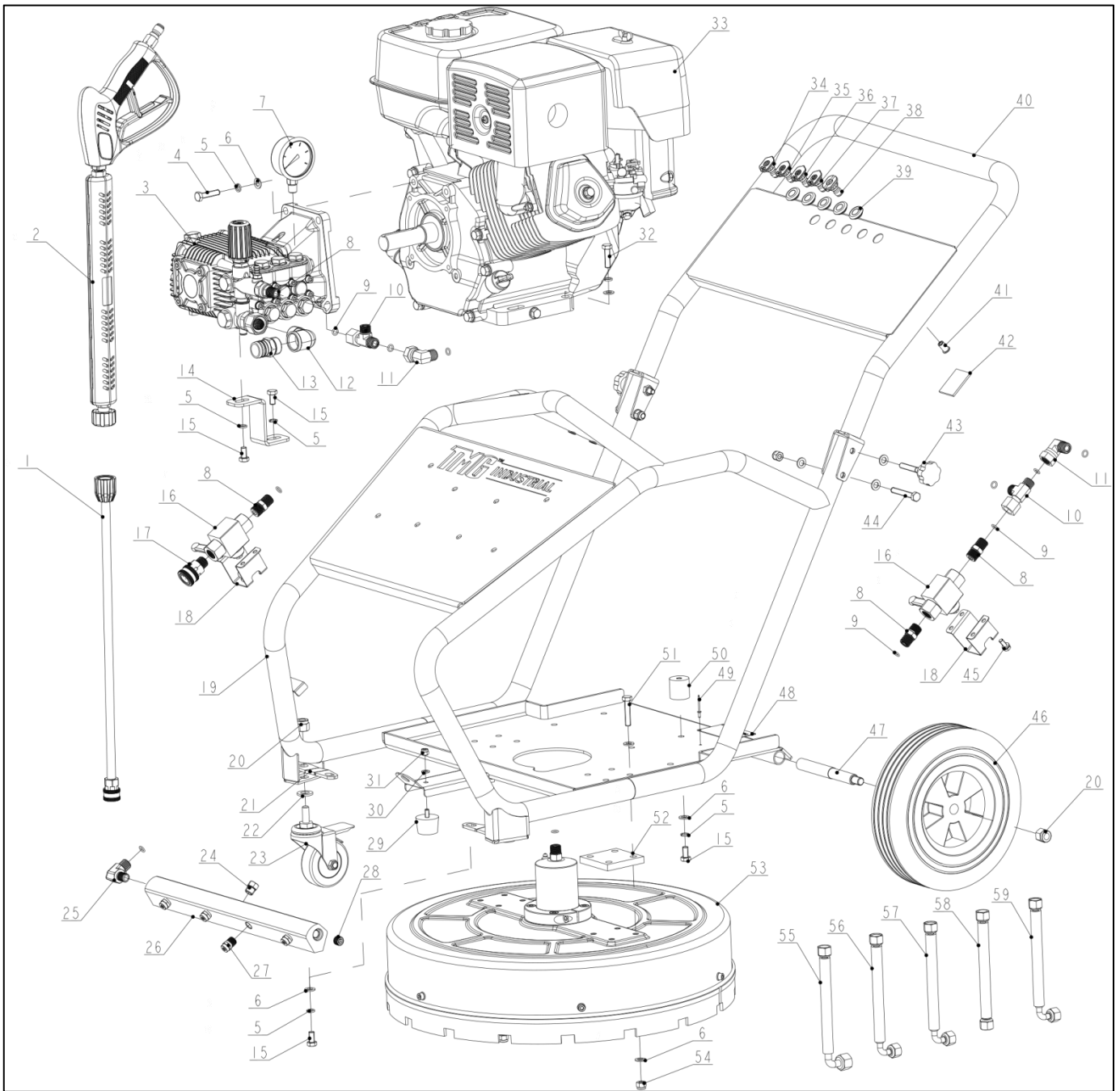

## 18. Exploded View & Parts List (Continued)

REF NO.	DESCRIPTION	Q'TY	REF NO.	DESCRIPTION	Q'TY
1	Spray wand	1	31	Nut M6	1
2	Pressure gun	1	32	Bolt M8x30	4
3	Pressure pump	1	33	Engine	1
4	Bolt M8x35	4	34	0 degree nozzle tip	1
5	Spring washer D8	17	35	15 degree nozzle tip	1
6	Plain washer D8	37	36	25 degree nozzle tip	1
7	Pressure gauge	1	37	40 degree nozzle tip	1
8	Connection fitting	6	38	Soap nozzle Tip	1
9	O-ring 7.65x1.78	14	39	Nozzle grommet	5
10	T connector	2	40	Handle	1
11	Elbow fitting	2	41	Nut M6x15	16
12	Elbow fitting	1	42	Rubber gasket	3
13	Hose barb	1	43	Bolt M8x56	2
14	Bracket	1	44	Bolt M8x55	2
15	Bolt M8x16	9	45	Bolt M6x16	12
16	Ball valve	3	46	Wheel	2
17	3/8 quick connector	1	47	Axle	2
18	Ball valve holder	3	48	Name plate	1
19	Frame	1	49	Clip D3x8	4
20	Nut M12	4	50	Anti-vebration feet	5
21	Fix plate	2	51	Bolt M8x40	8
22	Plain washer D12	2	52	Rubber gasket	2
23	Castor	2	53	Surface cleaner	1
24	Plug	1	54	Nut M8	10
25	Elbow fitting	1	55	Connection hose 0.95m	1
26	Water broom	1	56	Connection hose 1.2m	1
27	Thread nozzle	4	57	Connection hose 0.27m	1
28	Plug	1	58	Connection hose 1.05m	1
29	Rubber feet	1	59	Connection hose 0.4m	1
30	Plain washer D6	1			

## 18. Exploded View & Parts List (Continued)

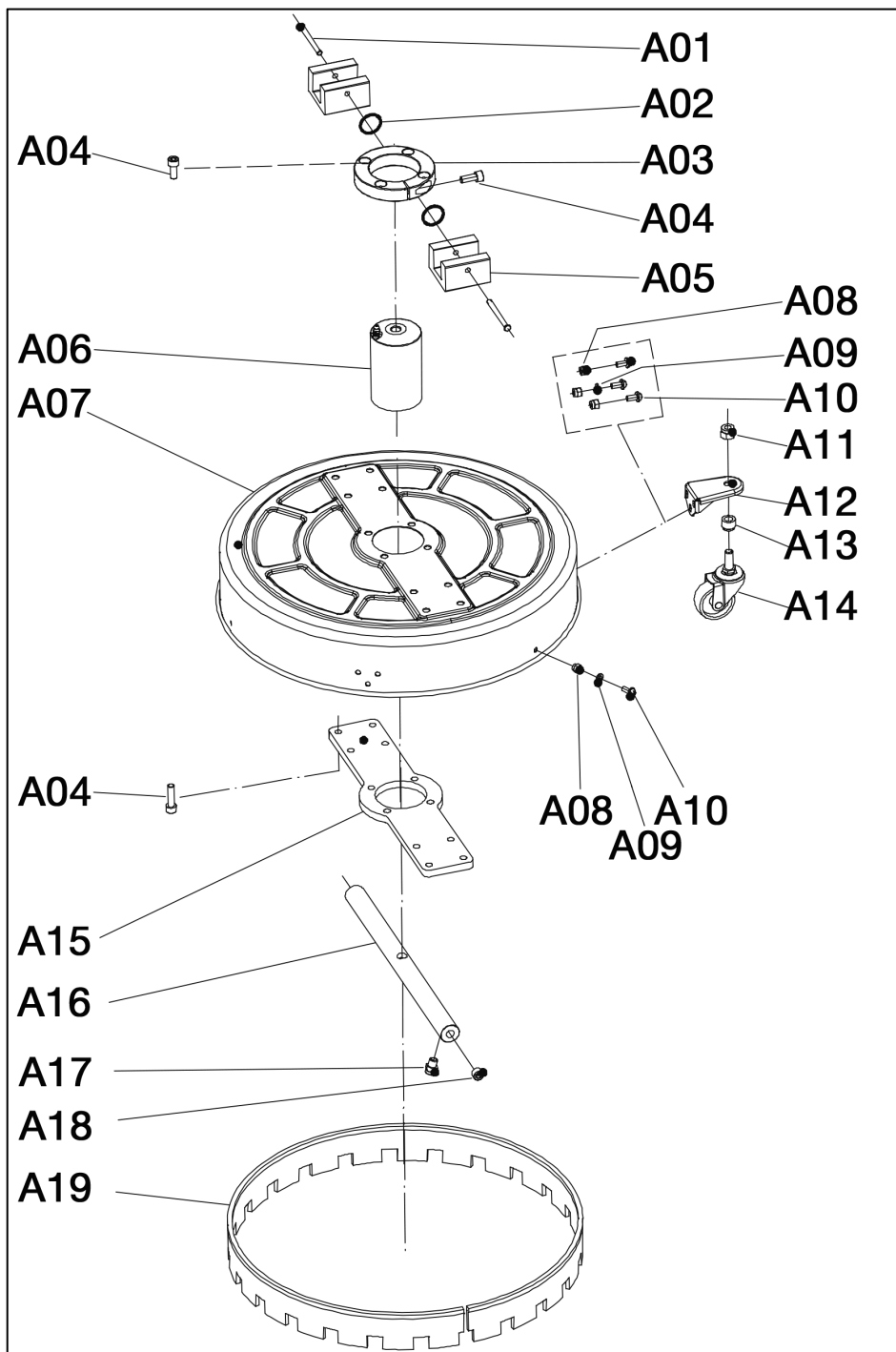

### SURFACE CLEANER ASSEMBLY

REF NO.	DESCRIPTION	Q'TY	REF NO.	DESCRIPTION	Q'TY
A01	Clevis pin	3	A11	Nut M10	4
A02	Bridge pin	3	A12	Fixing support	4
A03	Clamp ring	1	A13	Retainer	4
A04	Bolt	13	A14	Rotary wheel	4
A05	Aluminum support	2	A15	Lower plate	1
A06	Swivel assembly	1	A16	Spray bar	1
A07	Deck	1	A17	Spray nozzle	2
A08	Nut M6	16	A18	Screw	2
A09	Spacer	31	A19	Brush assembly	1
A10	Screw M6x14	16			

## 18. Exploded View & Parts List (Continued)

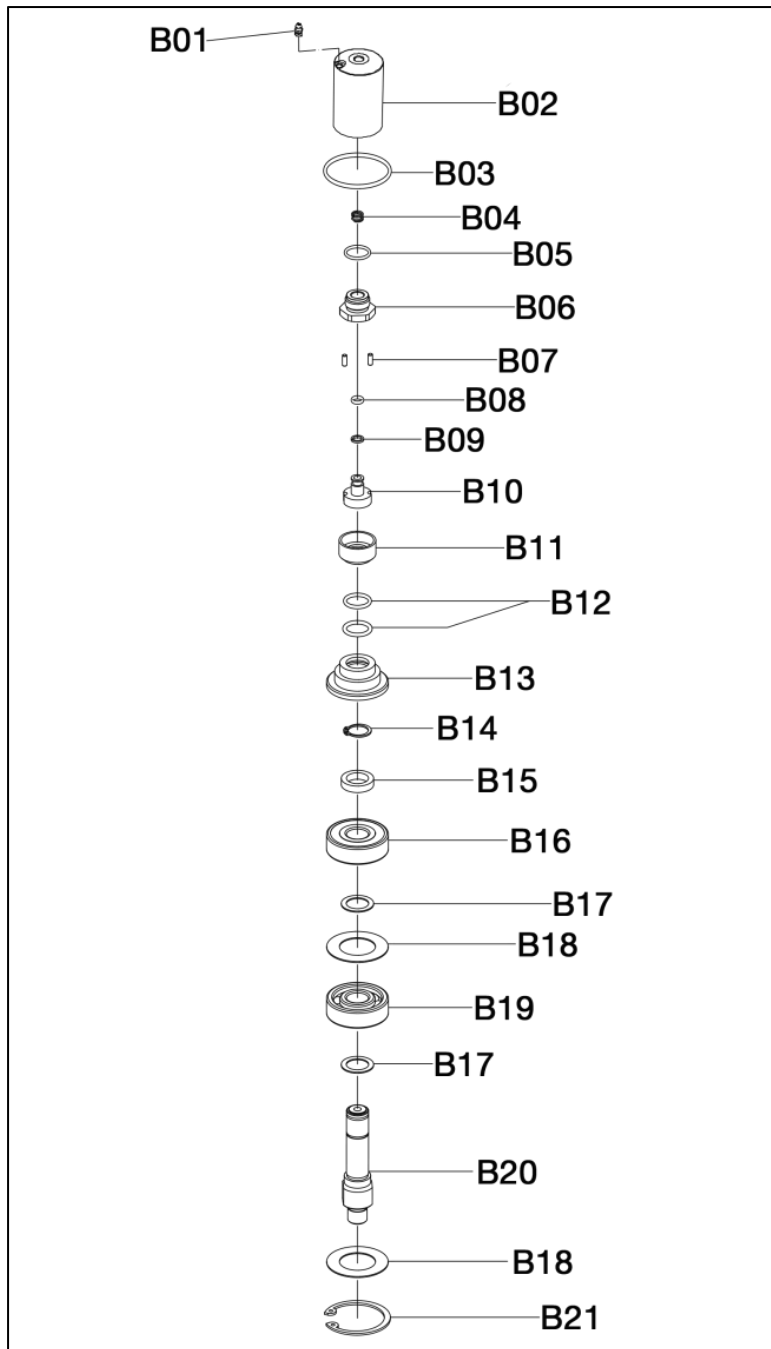

SWIVEL ASSEMBLY					
REF NO.	DESCRIPTION	Q'TY	REF NO.	DESCRIPTION	Q'TY
B01	Grease nipple	1	B12	O-ring	2
B02	Swivel housing	1	B13	Bearing retainer	1
B03	O-ring	1	B14	Snap ring	1
B04	Compression spring	1	B15	Bearing back-up ring	1
B05	O-ring	1	B16	Upper bearing	1
B06	Bolt	1	B17	Bearing spacer	1
B07	Pin	2	B18	Washer	1
B08	O-ring	1	B19	Lower bearing	1
B09	Back-up ring	1	B20	Rotor shaft	1
B10	Stem	1	B21	Snap ring	1
B11	Bearing retainer, small	1			

# 18. Exploded View & Parts List (Continued)

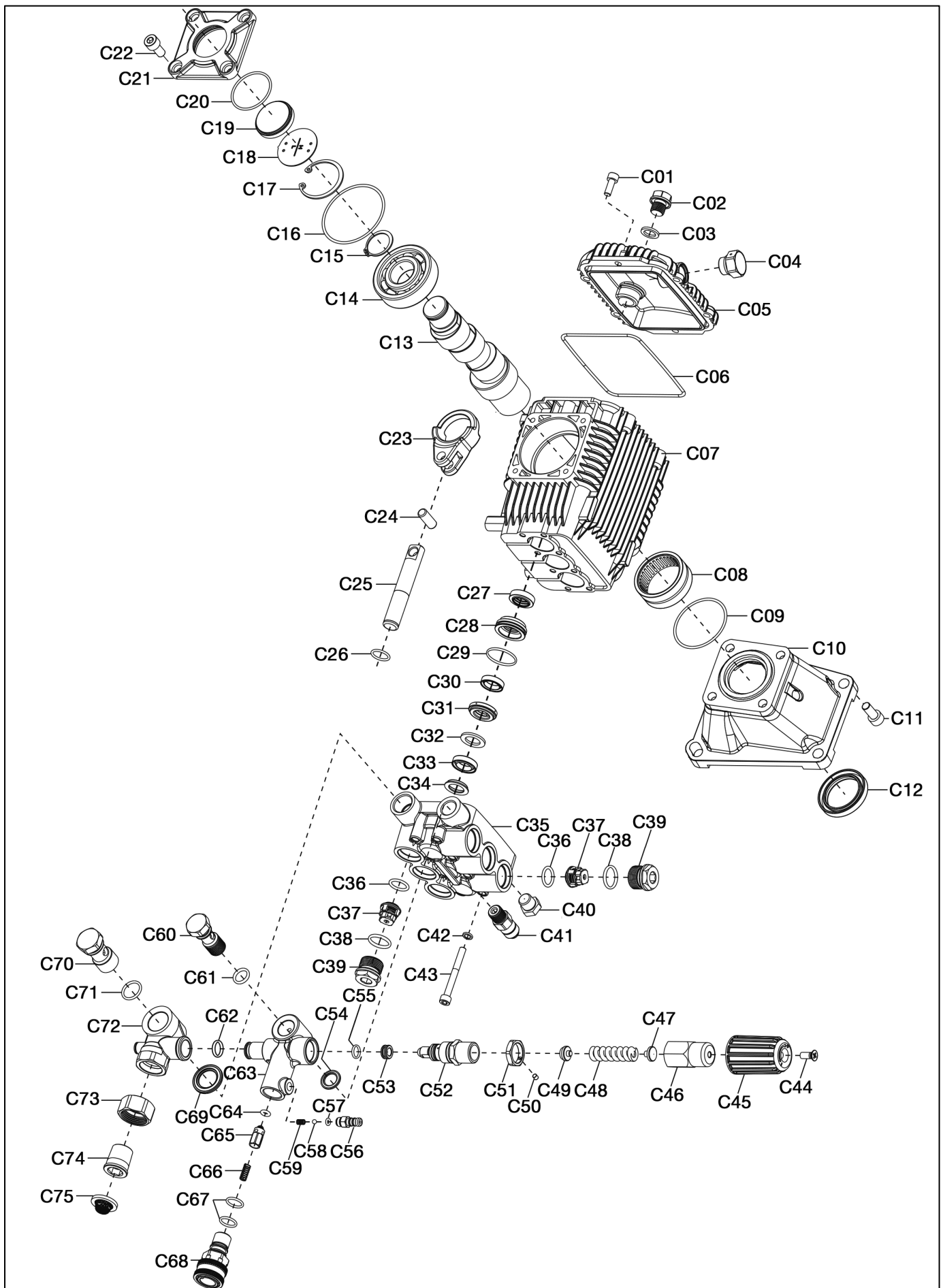

## 18. Exploded View & Parts List (Continued)

PRESSURE PUMP ASSEMBLY					
REF NO.	DESCRIPTION	Q'TY	REF NO.	DESCRIPTION	Q'TY
C01	Bolt, crankcase cover	6	C39	Checking valve cap	6
C02	Oil drain plug	1	C40	Outlet plug, manifold	1
C03	O-ring, oil drain plug	1	C41	Thermal relief valve	1
C04	Vented oil cap	1	C42	Washer, bolt, manifold	8
C05	Crankcase cover	1	C43	Bolt, manifold	8
C06	Gasket, crankcase cover	1	C44	Screw	1
C07	Crankcase	1	C45	Plastic cap, knob	1
C08	Needle bearing	1	C46	Pressure adjusting knob	1
C09	O-ring, flange	1	C47	Uper spring seat	1
C10	Flange	1	C48	Pressure adjusting spring	1
C11	Bolt, flange	4	C49	Spring seat	1
C12	Oil seal, flange	1	C50	Screw jam nut	1
C13	Crankshaft	1	C51	Pressure jam nut	1
C14	Ball bearing	1	C52	Unloader valve assy	1
C15	Scrap ring	1	C53	Valve seat	1
C16	O-ring, crankshaft cover	1	C54	O-ring, valve seat	1
C17	Retain ring	1	C55	Gasket, unloader valve housing	1
C18	Oil level plate	1	C56	Detergent injector fitting	1
C19	Oil sight glass	1	C57	O-ring, injector fitting	1
C20	O-ring, oil sight glass	1	C58	Ball, injector fitting	1
C21	Crankshaft cover	1	C59	Spring, injector fitting	1
C22	Bolt, crankshaft cover	4	C60	Water outlet banjo bolt	1
C23	Connecting rod	3	C61	O-ring, outlet banjo bolt	1
C24	Pin	3	C62	O-ring, unloader valve housing	2
C25	Ceramic coating plunger	3	C63	Unloader valve housing	1
C26	O-ring	3	C64	O-ring, outlet checking valve	1
C27	Oil seal, plunger	3	C65	Outlet checking valve	1
C28	Locating ring	3	C66	Spring, outlet checking valve	1
C29	O-ring, locating ring	3	C67	O-ring, outlet fitting	2
C30	Low pressure water seal	3	C68	Quick disconnect outlet fitting	1
C31	Compression ring	3	C69	Gasket, bypass housing	1
C32	Compression flake	3	C70	Water Inlet banjo bolt	1
C33	High pressure water seal	3	C71	O-ring, inlet banjo bolt	1
C34	Supporting ring	3	C72	Bypass housing	1
C35	Manifold	3	C73	Swivel nut, inlet connector	1
C36	O-ring, checking valve	6	C74	Body, inlet connector	1
C37	Checking valve assy	6	C75	Filter washer, inlet connector	1
C38	O-ring, valve cap	6			

