

25Ft x 80Ft Tunnel Greenhouse Grow Tent

Model: TMG-GH2580



- Please read the product manual completely before assembly
- Check against the parts list to make sure all parts are received
- Wear proper safety goggles or other protective gears while in assembly

Missing parts or questions on assembly?

Please call: 1-877-761-2819 or email: cs@tmgindustrial.com

Do not return the product to dealer, they are not equipped to handle your requests

Main specifications

- Overall assembled size : W7.62 x L24.7 x H3 (m) / W25 x L81 x H10 (ft)
- Shoulder height : H1.2 (m) / 4ft
- Door : W1.2 x H2 (m) / 4 x 6.6 (ft)

Prior to assembly

Please read the instructions carefully before installation. It is important to follow your local safety regulations and industry standards during installation. Regulations may include but are not limited to :

- Safety helmets, protective eyewear, and clothing
- Safety harnesses for all elevated workers
- Proper ladder, cage, and safety operation

Check all components and parts before installation. All parts are marked with a part number, please refer to the parts list to make sure you have all parts.















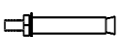

Choose a day with low or no wind to install, assembly is hard in heavy wind. Do not make any alterations to the structure. Do not hang any weights on the frame during installation, including parts. We are not responsible for any damages or injuries caused by inappropriate installation, unauthorized modifications or extreme weather.



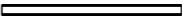







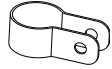



This building is not intended for human occupancy.









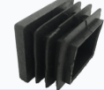

It is recommended to tape or add foam/rubber on the frame where joints connect and where it touches the cover. This will help extend the life span of the cover.

Read the following item list carefully and count the number of items to ensure that all parts are included prior to setup.

TMG-GH2580 Part List

Parts code	Graphical	Description	Qty
1		Peak arch tube	20
2		Upper rafter tube	40
3		Shoulder tube	36
3A		Shoulder tube (front and rear truss)	4
4		Roof purlin (horizontal tube)	133
5		Base plate	40
5B		Expansion bolt ϕ 14x100mm	136
6		Door column base plate	8
7		Vertical tubes	4
8L		Door left vertical tubes	2
8R		Door right vertical tubes	2
9		Door horizontal tube	8
9L		Door frame column left tube	2
9R		Door frame column right tube	2
10		Door cross tubes	4
10A		Door cross tubes	4
10B		Door frame cross pull tube	2
11		Ceiling cross bar	20

12		Tube clamp	12
13		Film rolling machine guide tube	2
14		Roll film tube	24
14A		Roll film tube	2
15		Door buckle	2
16		Film rolling machine	2
17		Reed groove	88
17A		Clip spring	88
18		Eight clip spring	78
19		Pressure film carrier	40
20		Half round head bolt M6x50	16
21		Self locking bolt M10x70mm and nuts	140
22		Hex bolt M10x70mm and nuts	272
23		Hex bolt M10x30mm and nuts	52
24		Hex bolt M10x100mm and nuts	2

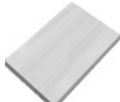
25		Self tapping screw #12x25	500
26		Self tapping screw #12x35	184
27		Square plug	8
28		Round plug (φ 25)	6
29		Braided rope	1 bundle (80m)
30		Top cover film	1
30A		Front and rear door film	2
31		Adhesive tape	9
32		Socket wrench	1
33		Hex wrench	1
34		Board 150x15x2000mm (not included)	58

Installation steps

Step 1 : Review the whole structure and choose the proper installation site.

- Mark the ground in the final building location with a line showing the positions of base plates, front doors. All lines should be drawn from center to center of all base plate tubes. Diagonal line X must be equal to Y.
- Base plates : all base plates must be installed firmly with expansion bolts (#5B) on this step.

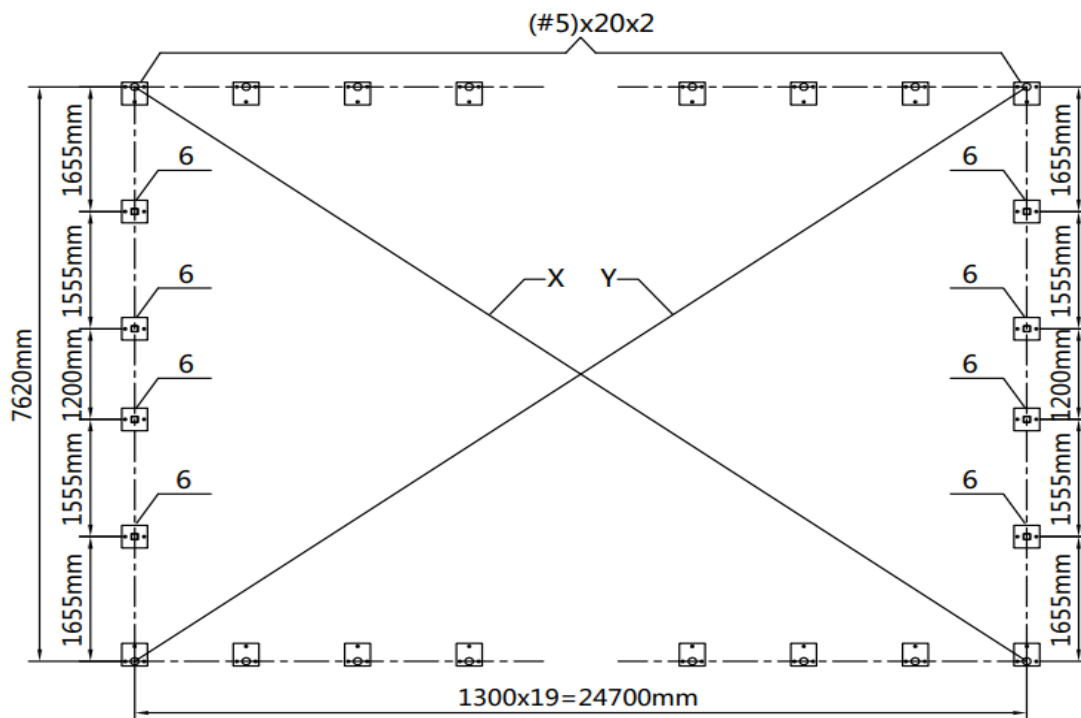

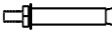

Figure 1

No.	Part	Qty
5		40
6		8
5B		136

Step 2 : Assemble all trusses.

- The building includes 20 trusses : (2) front and rear truss, and (18) middle trusses.
- Install front and rear trusses.

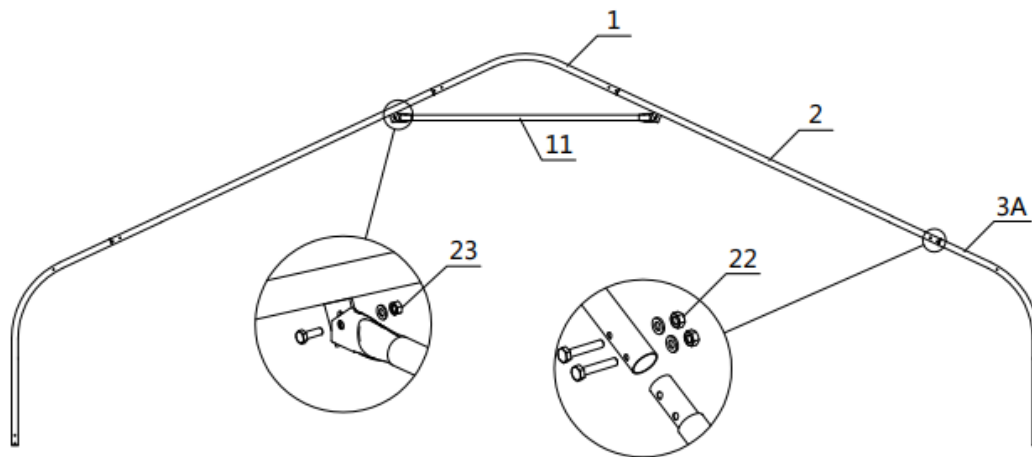







Figure 2

No.	Part	Qty
1		1x2
2		2x2
3A		2x2

No.	Part	Qty
11		1x2
22		8x2
23		2x2

- Install (18) middle trusses.

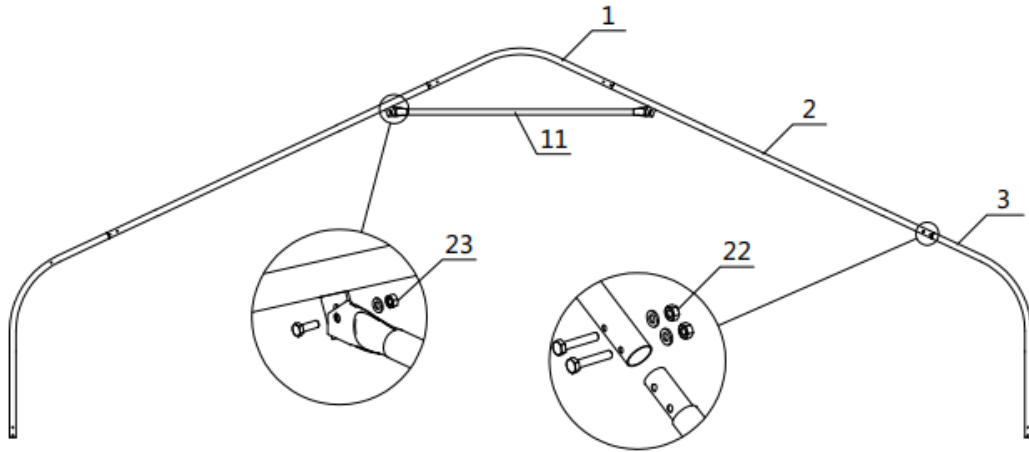



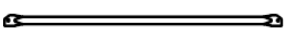



Figure3

No.	Part	Qty
1		1x18
2		2x18
3		2x18

No.	Part	Qty
11		1x18
22		8x18
23		2x18

- Lay down all (20) trusses on the ground when the assembly is all completed and before moving to next step, and then wrap (#31) around the sharp points of the joint to avoid friction between the fabric and the interface, resulting in fabric damage.

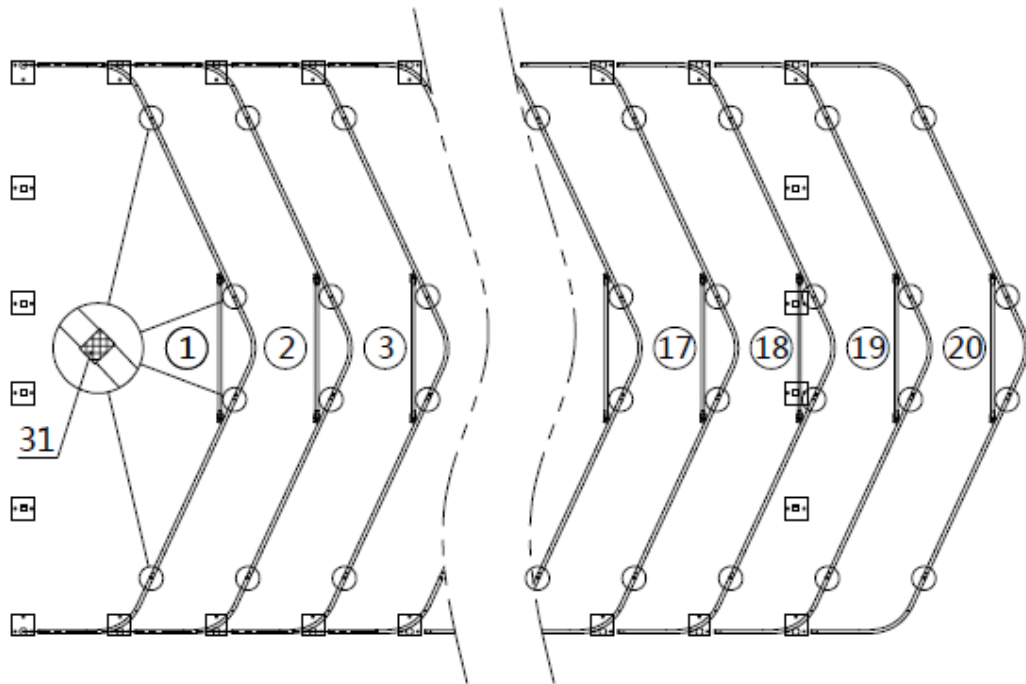



Figure 4

No.	Part	Qty
31		3

Step 3 : Put up all trusses.

- Put up the front truss, use hex bolt (#22) to secure the truss to the base plates.

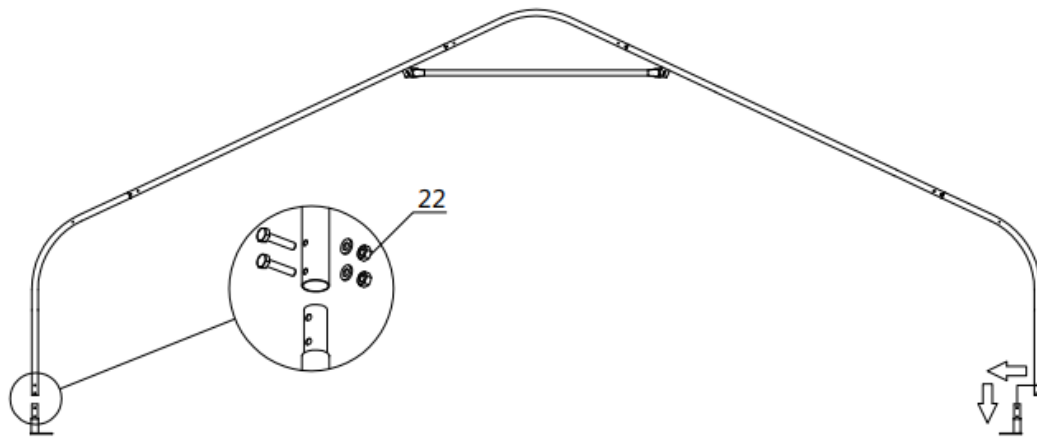

Figure 5

- Connect all purlins, and then wrap (#31) around the sharp points.

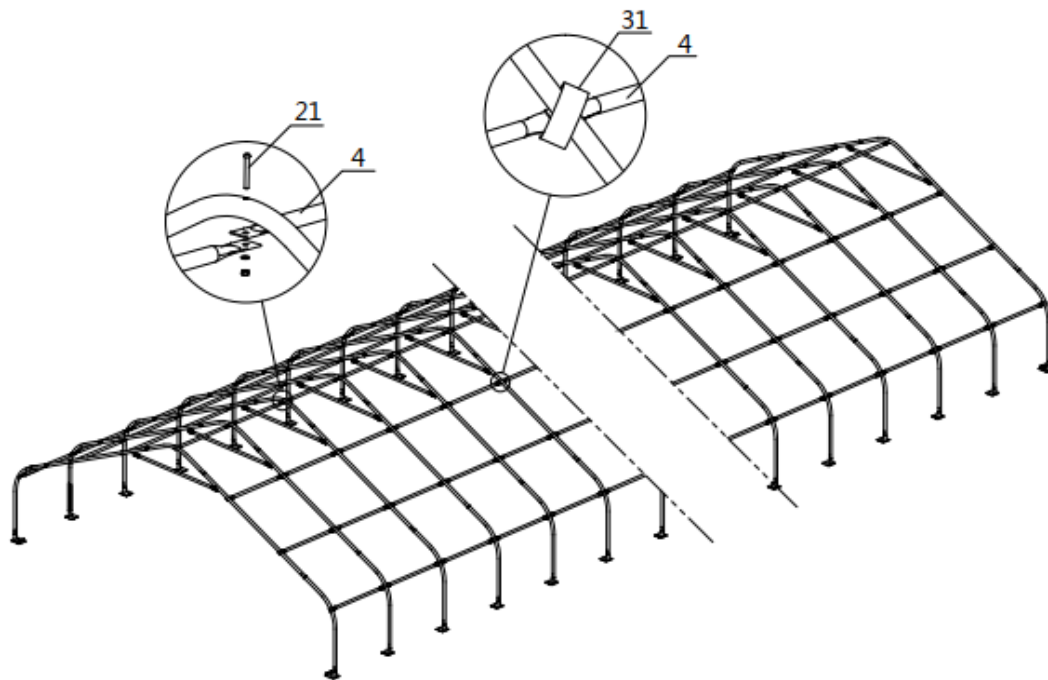





Figure 6

No.	Part	Qty
4		133
21		140

No.	Part	Qty
22		80
31		6

Step 4 : Installation of front and rear trusses.

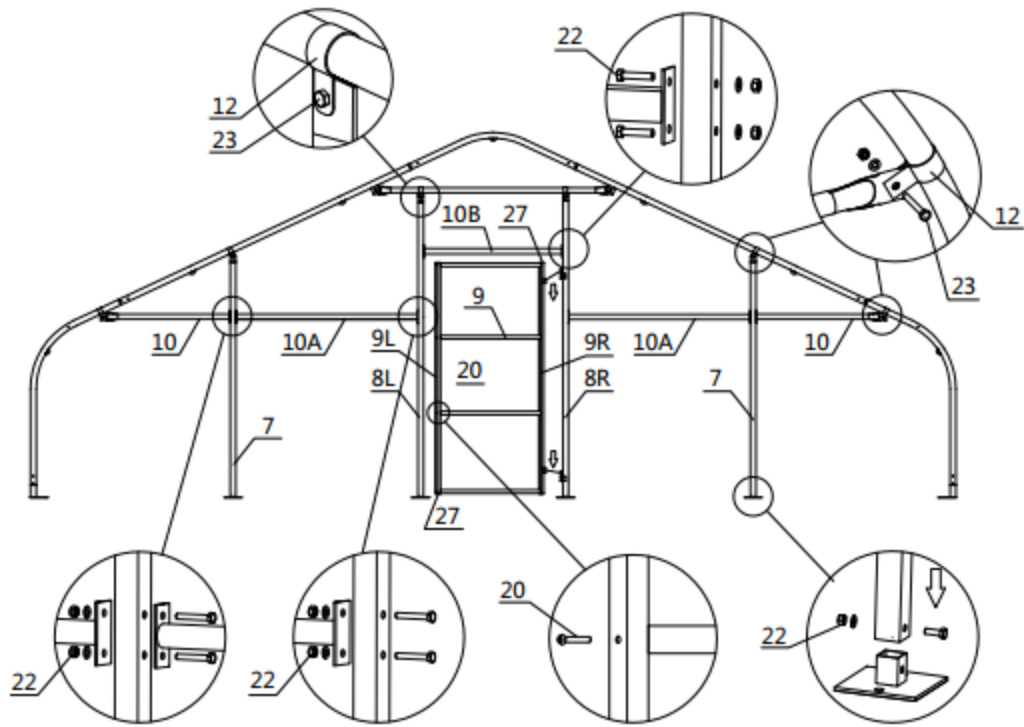



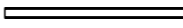











Figure 7

No.	Part	Qty
7		2x2
8L		1x2
8R		1x2
9		4x2
9L		1x2
9R		1x2
10		2x2

No.	Part	Qty
10A		2x2
10B		1x2
12		6x2
20		8x2
22		16x2
23		6x2
27		4x2

Step 5 : Install boards (#34) and reed groove (#17).

- Fix the board (#34) with self tapping screw (#26).
- Fix the reed groove (#17) with the self tapping screw (#25).
- Parts used in this step :
 - (88) Reed groove (#17)
 - (440) Self tapping screw (#25)
 - (184) Self tapping screw (#26)
 - (58) Boards (#34)

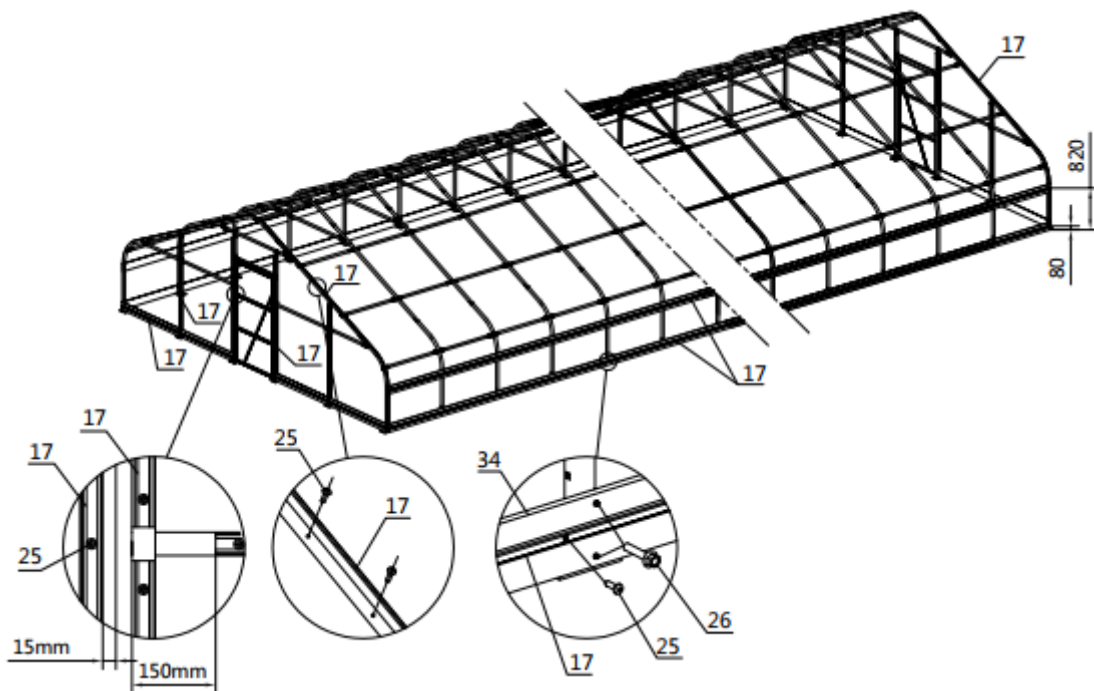



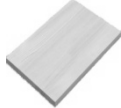

Figure 8

No.	Part	Qty
17		88
25		440

No.	Part	Qty
26		184
34		58

Step 6 : Install front and rear film.

- Lift the film (#30A) and fix the film with a clip spring (#17A) from top to bottom.
- Install door buckle (#15) with self tapping screw (#25).
- Cut the door film as shown.

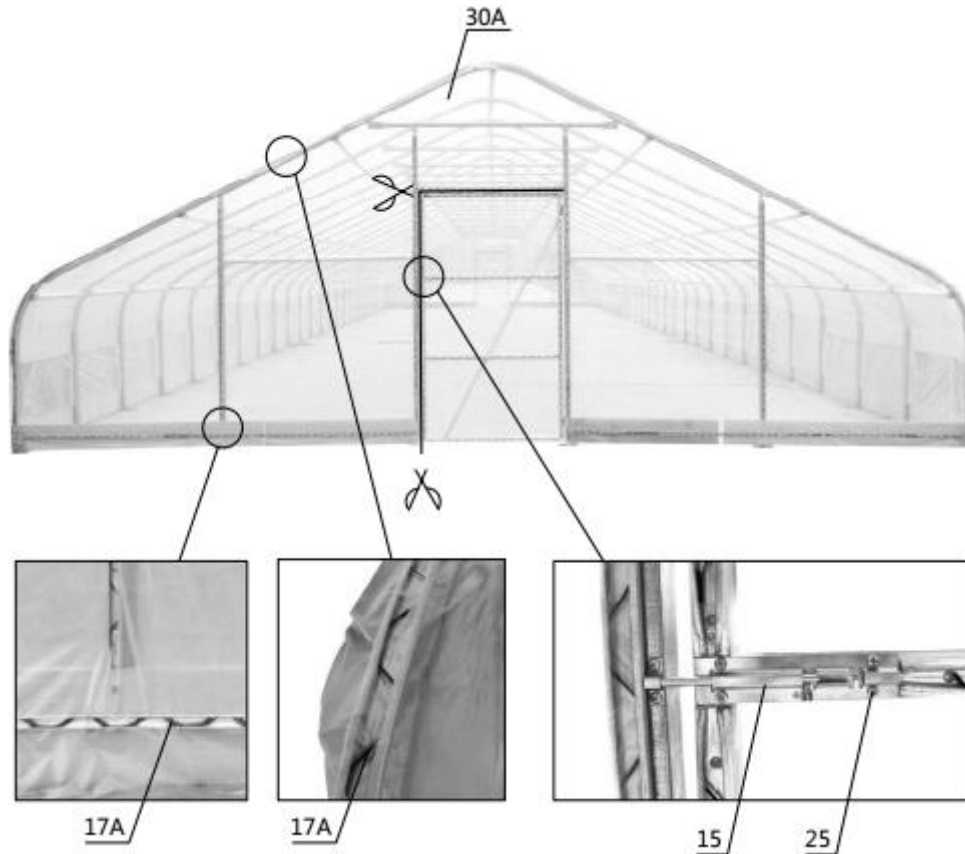



Figure 9

No.	Part	Qty
15		1x2
17A		19x2

No.	Part	Qty
25		6x2
30A		1x2

Step 7: Install top cover film.

- when you are ready to install the roof cover, unpack the cover and position it parallel to the building frame on one side. the cover must be pulled over the top of the truss frame without being snagged or stressed on any frame members. tighten the film evenly to eliminate wrinkles and make the film flat and smooth. Do not over-tighten during the adjustment process, otherwise it will cause unnecessary damage. At this time, you can install a clip spring (#17A) to fix the film.

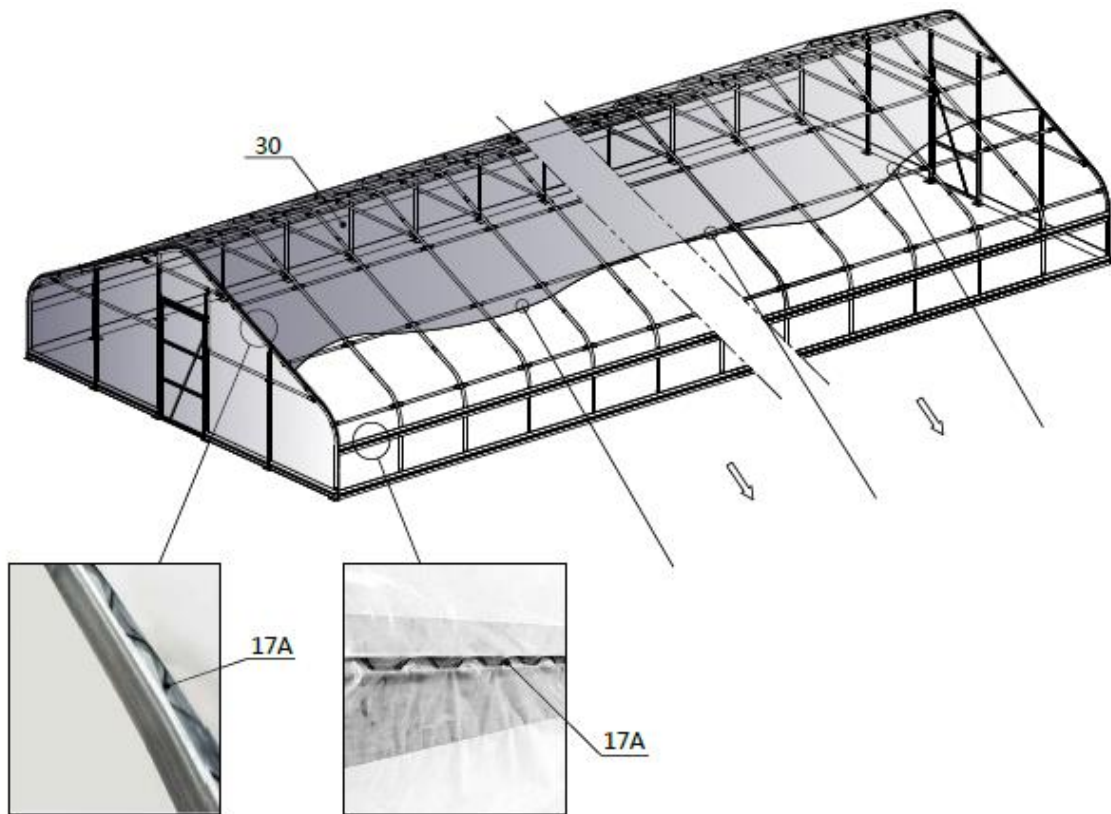



Figure 10

No.	Part	Qty
17A		50
30		1

Step 8 : Install roll film system.

- Install the roll film tube(#14), add a round plug(#28) at the end. the film (# 30) is wound on a roll film tube , and clamped with a pressure film carrier (# 19).

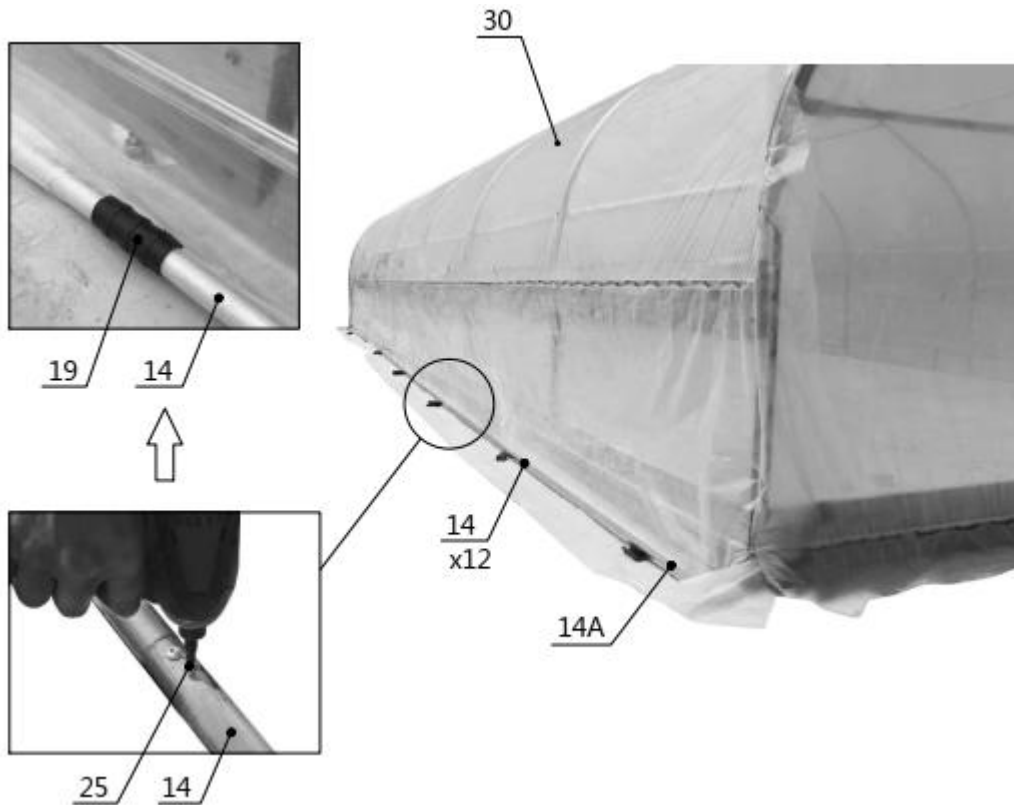

Figure 11

No.	Part	Qty
14		24
14A		2
19		40

No.	Part	Qty
25		48
28		2

- A round plug (# 28) is put on both ends of the film rolling machine guide tube (# 13), and the guide tube is mounted on the frame with a hex bolt (# 24), and it is required to swing freely. The film rolling machine (# 16) drives the roll film tube (# 14) to be raised and lowered horizontally and flexibly without jamming.

- Install the eight clip spring (# 18) and fasten the braided rope (# 29).

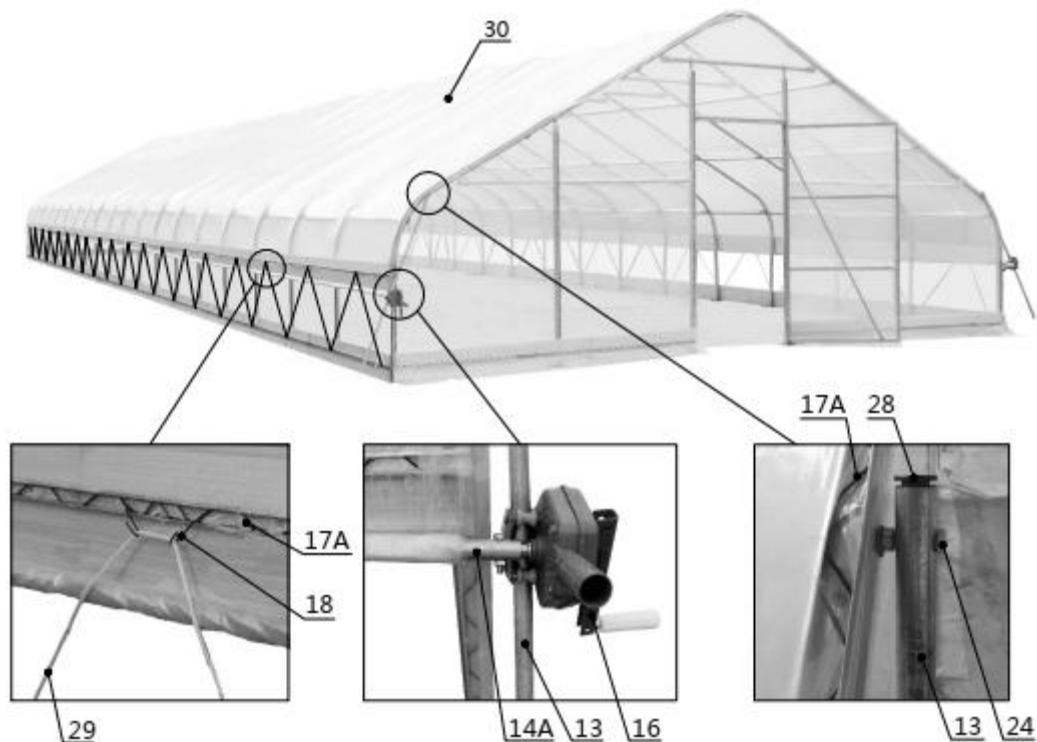







Figure 12

No.	Part	Qty
13		2
16		2
18		78

No.	Part	Qty
24		2
28		4
29		1

After the Installation

Walk around and inspect the shelter periodically to make sure all components are still firmly secured and the whole shelter is well supported. Check all bolts and nuts as well as all connection points to make sure they are all in good position.

We strongly recommend you remove any snow from the roof immediately. Do not leave any snow load on the roof overnight. Keep 3 feet of clearance on all sides at all times. Do not allow snow to accumulate and pile up on the sides of the building. Otherwise the pressure from the sides will push inwards and could lead to a collapse.