

### 10Ft x 20Ft Walk-In Peak Greenhouse

Model: TMG-GH1020P



- Please read the product manual completely before assembly
- Check against the parts list to make sure all parts are received
- Wear proper safety goggles or other protective gears while in assembly

Missing parts or questions on assembly?

Please call: 1-877-761-2819 or email: [cs@tmgindustrial.com](mailto:cs@tmgindustrial.com)

Do not return the product to dealer, they are not equipped to handle your requests

## **Main Specifications :**

- Assembly size : W3 x L6 x H2 (m) / 10 x 20 x 7 (ft)
- Front roll up door : 1.71 x 1 (m) / 5.6 x 3.2 (ft)

## **Prior to assembly**

Please read the instructions carefully before installation. It is important to follow your local safety regulations and industry standards during installation. Regulations may include but are not limited to :

- Safety helmets, protective eyewear, and clothing
- Safety harnesses for all elevated workers
- Proper ladder, cage, and safety operation

Check all components and parts before installation. All parts are marked with a part number, please refer to the parts list to make sure you have all parts.

Choose a day with low or no wind to install, assembly is hard in heavy wind. Do not make any alterations to the structure. Do not hang any weights on the frame during installation, including parts. We are not responsible for any damages or injuries caused by inappropriate installation, unauthorized modifications or extreme weather.

This building is not intended for human occupancy.

It is recommended to tape or add foam/rubber on the frame where joints connect and where it touches the cover. This will help extend the life span of the cover.

Read the following item list carefully and count the number of items to ensure that all parts are included prior to setup.

## **Installation steps**





### **Step 1 : Review the whole structure and choose the proper installation site**





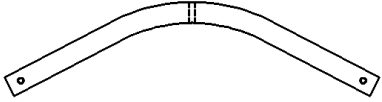
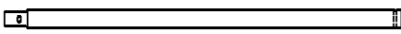

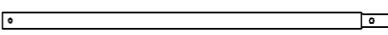

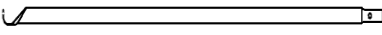
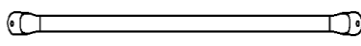
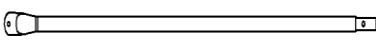
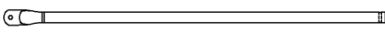
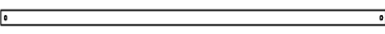

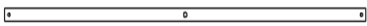

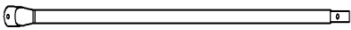
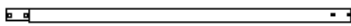
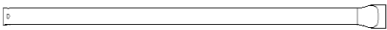
Choose a solid flat level ground area to set up the building. Do not install the building on soft ground, wetland, uneven surfaces, sloped surfaces, or on top of structures that are not rated to hold its weight.

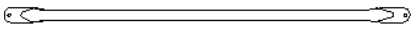
We strongly recommend that you build the structure on a solid foundation such as cement and use anchor bolts on all baseplates.

Be aware of the surrounding area. Do not set up the building near snowdrifts, open flames or exposed electrical wires. Do not keep heat sources near the fabric cover. Keep the building surroundings clear at all times.

### TMG-GH1020P Part List

Parts code	Graphical	Description	Qty	BOX
1		Peak arch tube	7	1/1
2		Middle rafter tube	14	1/1
3		Shoulder tube (middle truss)	10	1/1
3A		Shoulder tube (front and rear truss)	4	1/1
4		Lower rafter tube	14	1/1
5		Roof purlin (horizontal tube)	35	1/1
5A		Roof purlin (horizontal tube)	7	1/1
6		Bottom tension bar (front and rear cover)	4	1/1
6A		Door frame horizontal tube (front truss)	2	1/1
6B		Frame horizontal tube (rear truss)	1	1/1
6C		Frame horizontal tube (rear truss)	1	1/1
7		Door frame lower horizontal tube (front truss)	1	1/1

7A		Bottom tension bar (rear cover)	1	1/1
7B		Ceiling cross bar (front truss)	1	1/1
8		Door frame lower tube (front and rear truss)	3	1/1
8A		Door frame upper tube (front truss)	2	1/1
8B		Upper tube (rear truss)	1	1/1
9		Tube clamp	6	1/1
10		Diagonal bracing bar (1st and last span)	4	1/1
11		Mushroom head hexagon socket head bolt M6x65mm	50	1/1
12		Mushroom head hexagon socket head bolt M6x40mm	35	1/1
13		Mushroom head hexagon socket head bolt M6x30mm	6	1/1
14		Riding clip	16	1/1
15		Cover	1	1/1
16		Expansion bolt M8x100mm	32	1/1
17		Water plug	28	1/1
18		Hexagon wrench	2	1/1

## Step 2 : Assemble all trusses

- The building includes 7 trusses : (1) front truss, (1) rear truss, and (5) middle trusses. The front truss fabric panels and the top fabric (#15) have been connected as a whole.
- Parts used to install the front truss in this step (refer to Figure 1) :
  - (1) Peak arch tube (#1)
  - (2) Middle rafter tube (#2)
  - (2) Shoulder tube (#3A)
  - (2) Lower rafter tube (#4)
  - (4) Mushroom head hexagon socket head bolt (#11)
  - (2) Mushroom head hexagon socket head bolt (#12)

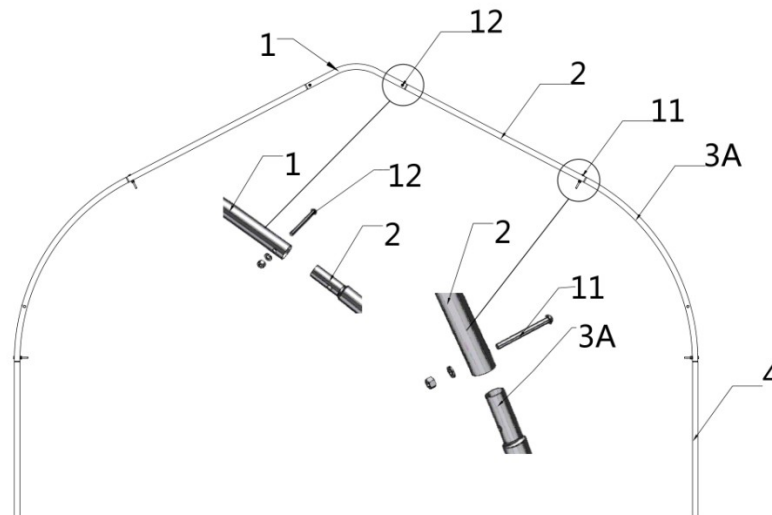

**Figure 1**

- Parts used to install the rear truss in this step (refer to Figure 2) :
  - (1) Peak arch tube (#1)
  - (2) Middle rafter tube (#2)
  - (2) Shoulder tube (#3A)
  - (2) Lower rafter tube (#4)
  - (4) Mushroom head hexagon socket head bolt (#11)
  - (2) Mushroom head hexagon socket head bolt (#12)

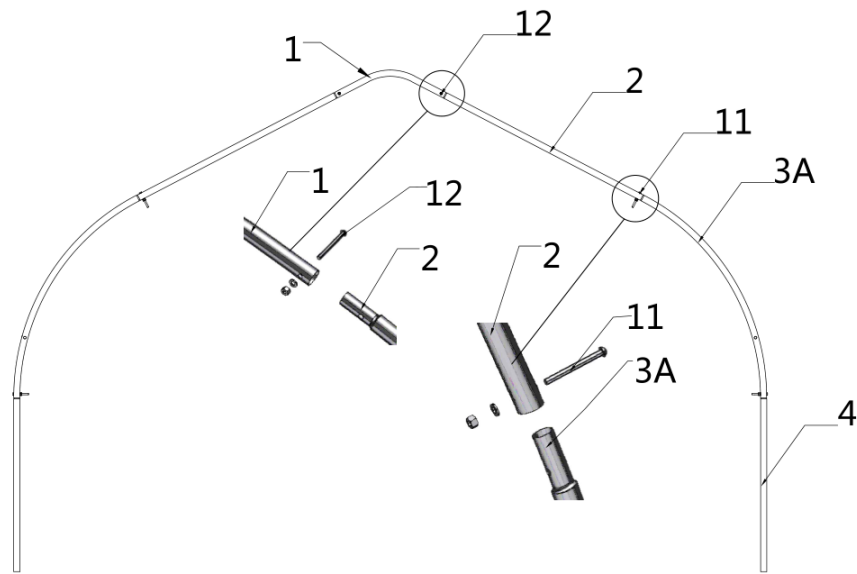

**Figure 2**

- Parts used to install (5) middle trusses in this step (refer to Figure 3).
  - (1x5) Peak arch tube (#1)
  - (2x5) Middle rafter tube (#2)
  - (2x5) Shoulder tube (#3)
  - (2x5) Lower rafter tube (#4)
  - (4x5) Mushroom head hexagon socket head bolt (#11)
  - (2x5) Mushroom head hexagon socket head bolt (#12)

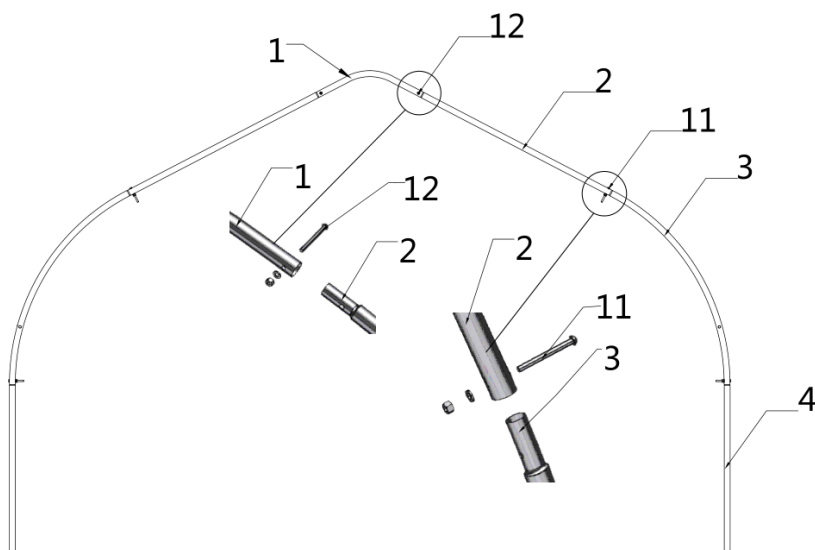

**Figure 3**

- Lay down all (7) trusses on the ground as Figure 4 when the assembly is all completed and before moving to next step.

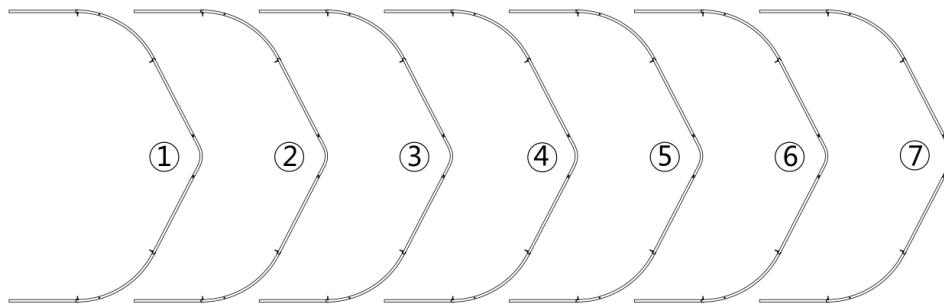

**Figure 4**

### Step 3 : Put up the front (1<sup>st</sup>) truss

- First, erect the front truss. We suggest two or three people. One to two people hold the truss and keep it upright and stable, while the other person installs the roof purlin (#5). Use mushroom head hexagon socket (#11) to link the truss to the roof purlin, and then tighten all bolts. (refer to Figure 5)

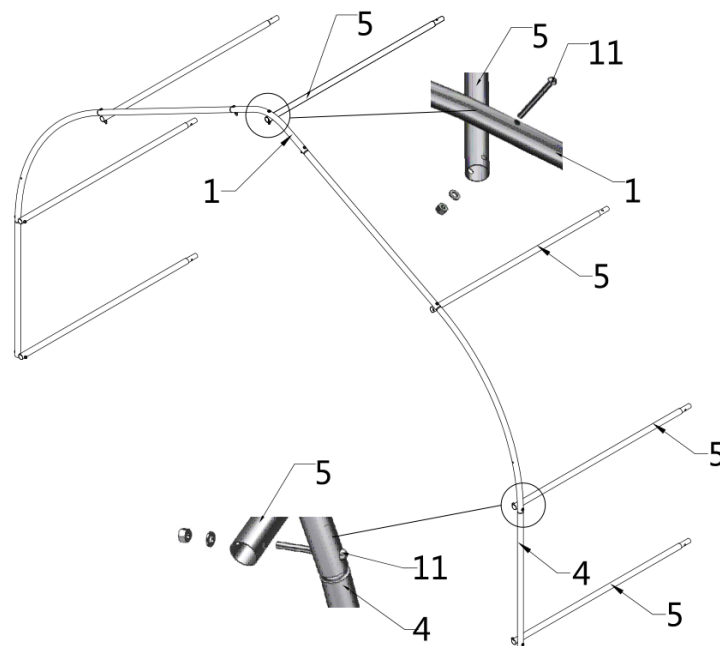

**Figure 5**

#### Step 4 : Put up the rest middle trusses

- Repeat the previous step to erect the second span truss, and then connect the other end of the roof purlin (#5) with the truss use mushroom head hexagon socket (#11), and complete the installation of the second truss to the sixth truss in turn. (refer to Figure 6)

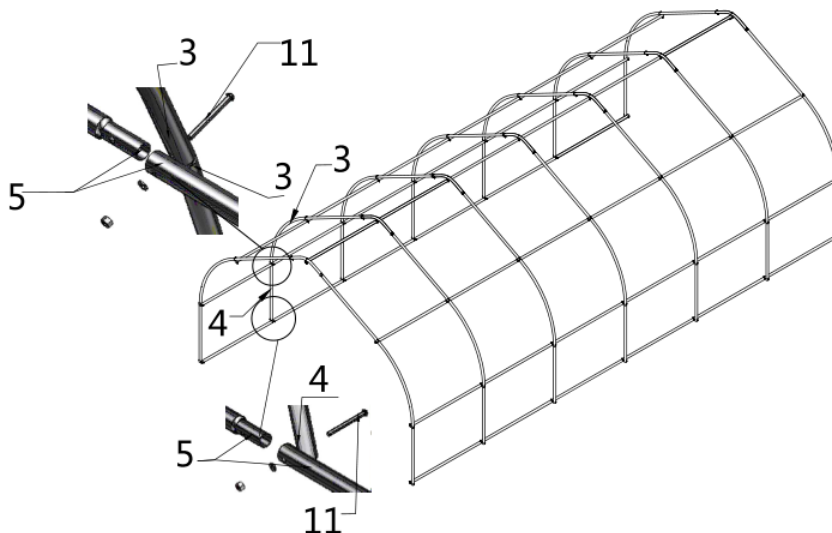

**Figure 6**

#### Step 5 : Put up the rest rear trusses

- Finally, the rear truss (the 7th span truss) is erected, and then the roof purlin (#5A) is connected with the truss with mushroom head hexagon socket (#11). (refer to Figure 7)

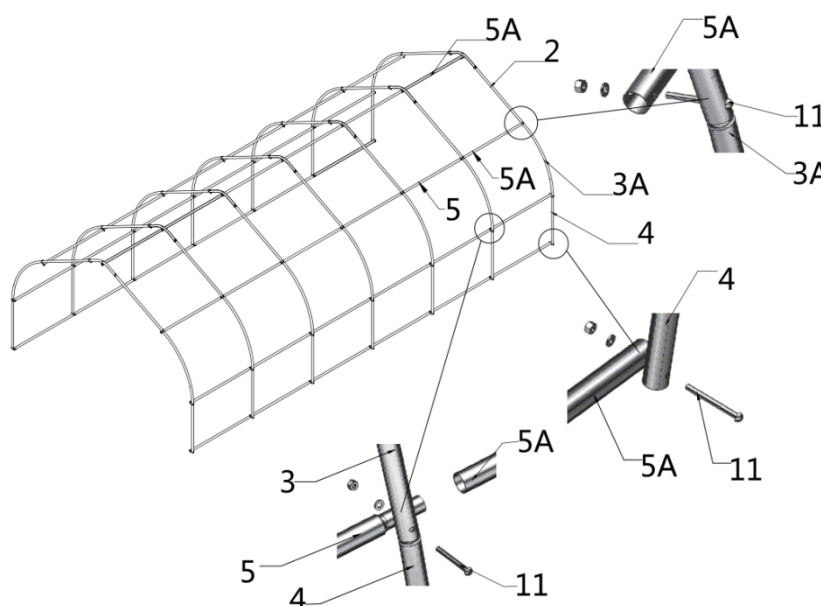
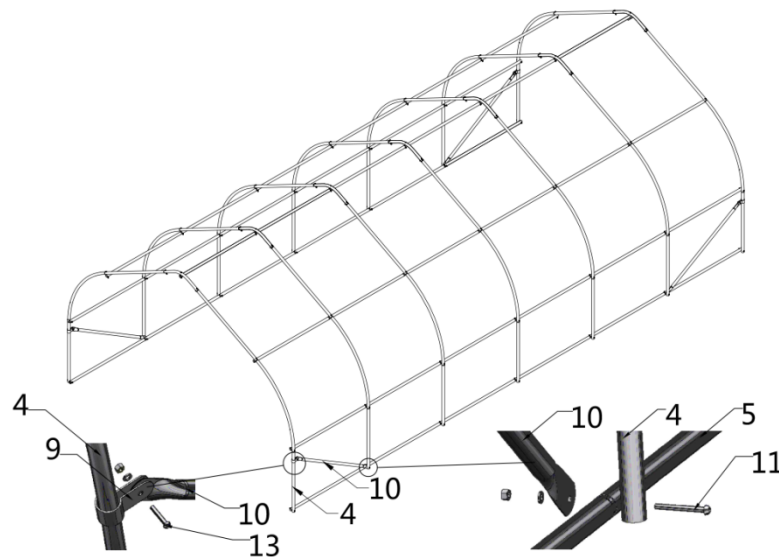

**Figure 7**



## Step 6 : Install the diagonal bracing bars (#10)

- Connect diagonal bracing bar (#10) on the first and last span between the lower rafter tube (#4) with tube clamp (#9), use mushroom head hexagon socket head bolt (#13) and ( #11) (Figure 8)
- Parts used in this step :
  - (4) Diagonal bracing bar (#10)
  - (4) Tube clamp (#9)
  - (4) Mushroom head hexagon socket head bolt (#11)
  - (4) Mushroom head hexagon socket head bolt (#13)



**Figure 8**

## Step 7 : Install the remaining parts on the front truss (Figure 9)

- Parts used in this step :
  - (2) Bottom tension bar (#6)
  - (2) Door frame horizontal tube (#6A)
  - (1) Door frame lower horizontal tube (#7)
  - (1) Ceiling cross bar (#7B)
  - (2) Door frame lower tube (#8)
  - (2) Door frame upper tube (#8A)
  - (2) Tube clamp (#9)
  - (7) Mushroom head hexagon socket head bolt (#11)
  - (6) Mushroom head hexagon socket head bolt (#12)
  - (2) Mushroom head hexagon socket head bolt (#13)

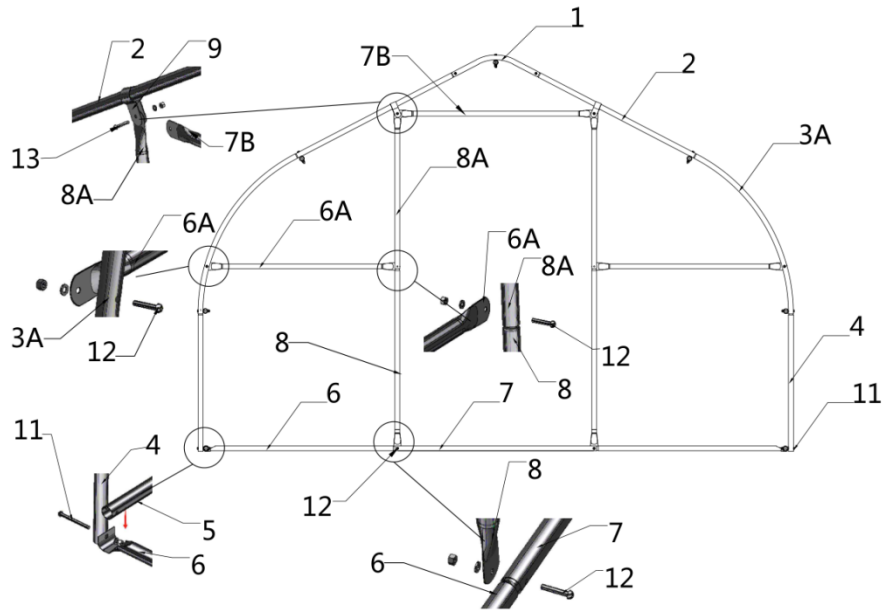

**Figure 9**

**Step 8 : Install the remaining parts on the rear truss (Figure 10)**

- Parts used in this step :
  - (2) Bottom tension bar (#6)
  - (1) Frame horizontal tube (#6B)
  - (1) Frame horizontal tube (#6C)
  - (1) Bottom tension bar (#7A)
  - (1) Door frame lower tube (#8)
  - (1) Upper tube (#8B)
  - (4) Mushroom head hexagon socket head bolt (#11)
  - (5) Mushroom head hexagon socket head bolt (#12)

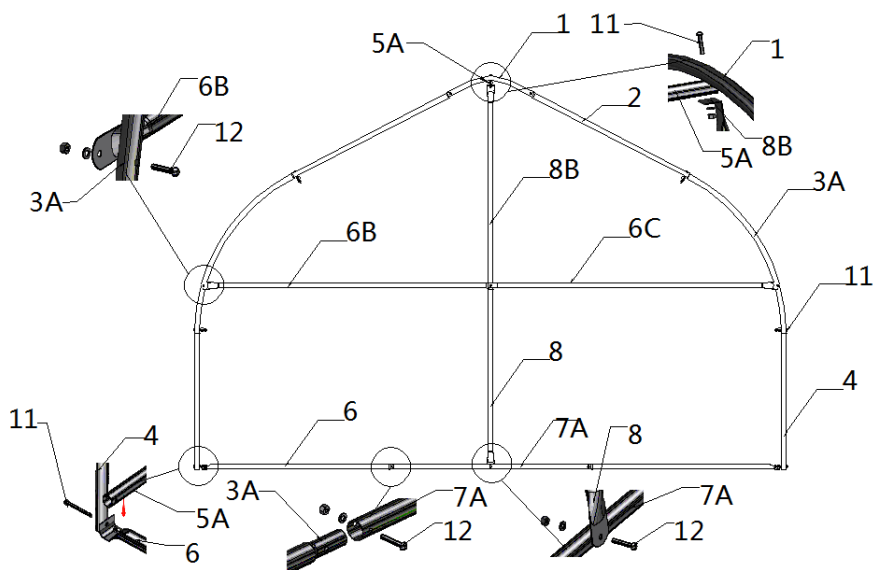

**Figure 10**

### Step 9 : install the waterproof plug and fix the truss

- The ends of lower rafter tube (#4) at the part of the truss, as well as the outer ends of roof purlin (#5) and (#5A) at the front and rear truss, shall be provided with water plug (#17). (refer to Figure 11)

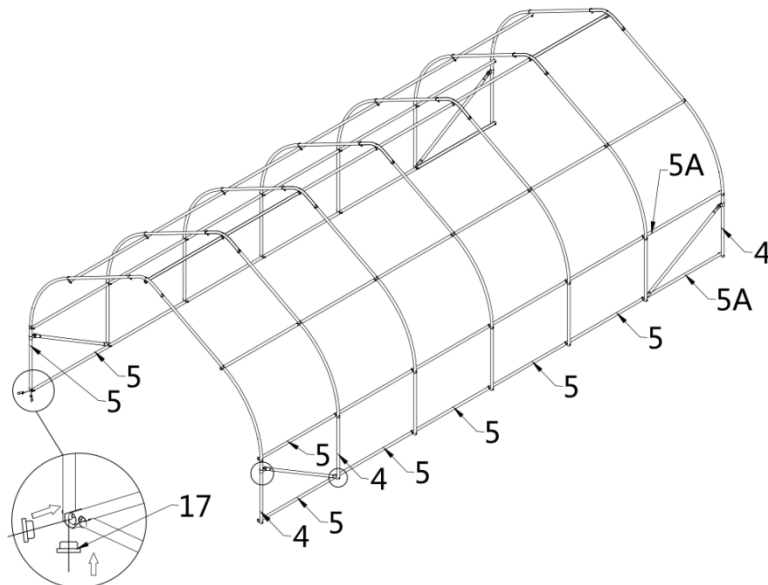

Figure 11

### Step 10 : Installation of riding clamp

- Fix the roof purlin (#5) and (#5A) close to the ground on the concrete ground with riding clip (#13) and expansion bolt (#16). The installation dimension shown in the figure is for reference (refer to Figure 12). If the truss is installed on the earth ground, it needs to be fixed by inserting at least 30cm steel bars (not equipped with this product cloth) into the riding clamp.

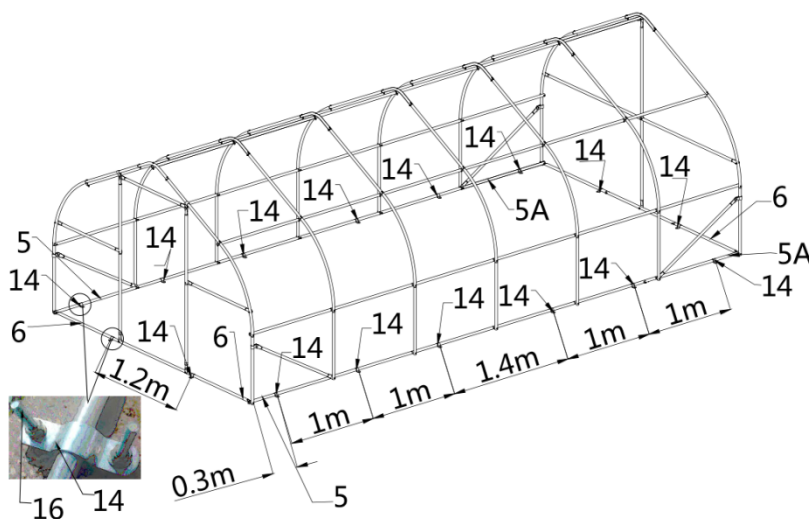

Figure 12

### Step 11 : Installing fabric panel

- Lift the cover (#15) to fully cover the truss, noting that the side with the door needs to be placed on the front door arch. Then adjust the four sides evenly (refer to Figure 13)



Figure 13

### Step 12 : Knitted fabric

- Tie the left and right sides of the fabric and the rear truss to eliminate wrinkles. The fabric is tensioned and tied to the roof purlin (#5) and (#5A) at the lower part of the truss, Bottom tension bar (#6) and (#7A) at the lower part of the rear truss with the Velcro on the fabric. (refer to Figure 14)

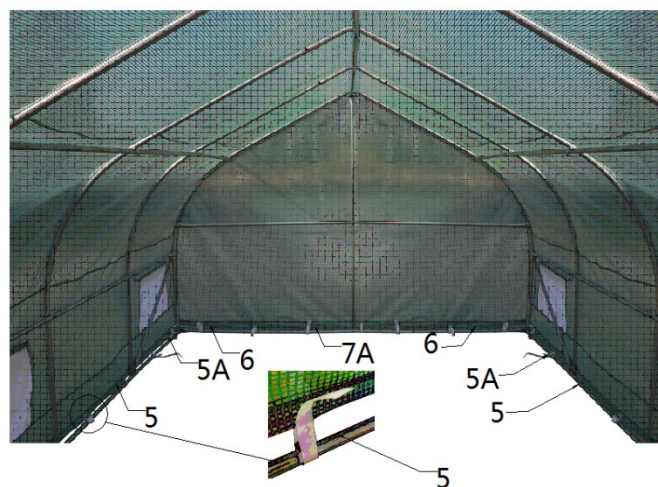
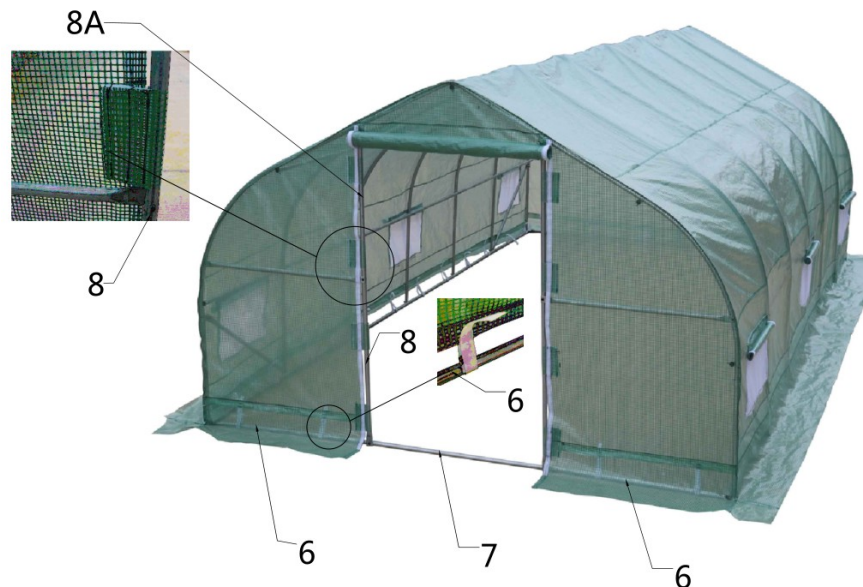

Figure 14

- Fasten the fabric front door. Use the Velcro on the fabric to tie the fabric tightly to the bottom tension bar (#6) at the lower part of the front truss door frame lower tube (#8) and door frame upper tube (#8A).



**Figure 15**

## After the Installation

Inspect the building periodically to make sure the parts are firmly fixed and the whole building is well supported. Check all bolts and hardware connectors to make sure they are in place and tightened. Check the base plates, adjust the ropes if necessary and clean the cover regularly.

Snow accumulating on the fabric cover must be removed as soon as possible. If the snow had become the solid ice on the cover, it would increase the burden of the roof and collapse the building eventually or reduce the life span.

Keep the building on a dry ground condition most of the time. Do not keep the fabric dirt skirt under water all the time, otherwise the fabric will deteriorate easily.

We strongly recommend you remove any snow from the roof immediately. Do not leave any snow load on the roof overnight. Keep 1 meter clearance from both sides and two ends of the ground all the time. Do not allow snow to accumulate and pile up on both sides of the building. Otherwise the pressure from both sides will push toward the building and make it collapse eventually.