

# 40Gallon Two-Stage Air Compressor

Models:TMG-GAC40

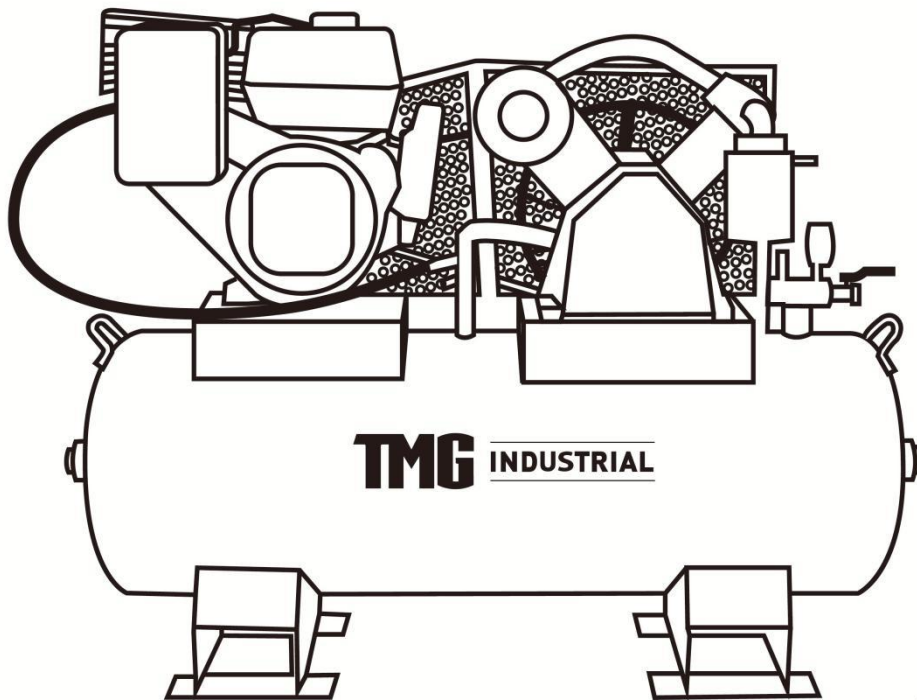

- Please read the product manual completely before assembly
- Check against the parts list to make sure all parts are received
- Wear proper safety goggles or other protective gears while in assembly

Missing parts or questions on assembly?

Please call: 1-877-761-2819 or email: [cs@tmgindustrial.com](mailto:cs@tmgindustrial.com)

Do not return the product to dealer, they are not equipped to handle your requests

# Gasoline Stationary Air Compressor

## (For Outdoor Use only)

This belt-driven compressor has a 2-stage 2-cylinder pump, an engine with cast iron cylinders for long life, and a compact design rated for 175 maximum PSI. Its continuous-duty rating ensures long-lasting performance, and its cast iron pump head ensures superior heat dissipation. Lift eyes are provided for lifting or tying down.

Read and understand this Owner's Manual completely before using and keep this manual for review. Failure to properly set up, operate, and maintain this compressor in accordance to this manual could result in injury or death to operator or bystanders.

### **WARNING: SPECIAL HAZARDS**

- **CO Poisoning:** Exhaust from engine contains carbon monoxide, a poisonous gas that can cause carbon monoxide poisoning and possible death if inhaled. ONLY run air compressor OUTDOORS and at least 20 feet from the home, away from windows, vents and air intakes, to allow proper ventilation. If you start to feel sick, dizzy, or weak while using the air compressor, shut off the engine and get to fresh air RIGHT AWAY.
- **Injection Injury:** High-pressure air stream can pierce skin and underlying tissues, leading to serious injury and possible amputation. Such an injection injury can result in blood poisoning and/or severe tissue damage.
- **Flying Debris:** High-pressure air stream can cause flying debris and possible surface damage.
- **Electric shock:** Operating equipment in wet conditions or near water can cause electric shock.
- **Not For Breathing Air:** compressors are NOT designed, intended, or approved for supplying breathing air. No compressed air should be used for breathing unless air is treated in accordance with applicable standards.
- **Fire/Explosion:** Sparks from air powered tool heads or attachments can ignite fuel or other flammable liquids or vapors in the vicinity. Exceeding the maximum pressure for air tools or attachments could cause them to explode.
- **Burns:** Compressor pump, engine and discharge tubing are hot surfaces that can cause burn injuries. Detailed safety information about these hazards appears throughout this manual.

### Equipment Protection Quick Facts

**Inspect Upon Delivery:** FIRST! Inspect for missing or damaged components. See “*Initial Set-Up*” section for where to report missing or damaged parts.

**Add Engine Oil:** Engine is shipped **without oil**. See engine manual for instructions on capacity and viscosity recommendations.

**Check Pump Oil:** Pump is shipped with oil. Check the pump oil level before starting. See “*Preparing for Operation*” section of this Owner's Manual for capacity and viscosity.

**Use Mechanical Lifting Equipment:** Compressor is shipped on a pallet and is too heavy to handle manually. Use proper lifting equipment for unloading and moving to installation site. Lifting eyes are provided.

**Run Pump Unloaded for Break-in Period:** Before initial use, open ball valve and run compressor for 20 minutes to break in pump parts.

**Follow Maintenance Schedule:** Engine, pump, air filter, and tank require periodic inspection and servicing to keep compressor functioning efficiently. See “*Maintenance Schedule Summary*” for frequency of servicing.

# Table of Contents

<b>EQUIPMENT PROTECTION QUICK FACTS.....</b>	<b>2</b>
<b>TABLE OF CONTENTS.....</b>	<b>3</b>
<b>ABOUT YOUR AIR COMPRESSOR.....</b>	<b>5</b>
<b>SPECIFICATIONS.....</b>	<b>6</b>
<b>COMPONENT IDENTIFICATION.....</b>	<b>7</b>
<b>SAFETY.....</b>	<b>8</b>
Hazard Signal Word Definitions.....	8
<b>SAFETY LABELING.....</b>	<b>9</b>
Safety Decal Locations.....	9
Safety Decals.....	10
<b>INITIAL SET-UP.....</b>	<b>11</b>
<b>Step 1. Inspect &amp; Unpack.....</b>	<b>11</b>
<b>Step 2. Select Suitable Location.....</b>	<b>11</b>
Outdoor Use Only.....	11
<b>Step 3. Mounting.....</b>	<b>12</b>
Mounting on Service Vehicle.....	12
Installing Discharge Piping.....	12
<b>Step 4. Electrical Starting: Battery Procedure.....</b>	<b>12</b>
Battery Connection.....	12
Battery Disconnection.....	13
Install Spark Arrestor(if Required).....	13
<b>OPERATION.....</b>	<b>14</b>
<b>Follow Safety Rules for Operation.....</b>	<b>14</b>
<b>Preparing for Operation.....</b>	<b>14</b>
Check/Add Oil to the Engine and Pump.....	14
Check and Fill Gasoline Tank.....	15
Inspect Fuel System/Check for Leaks.....	15
<b>Start-Up Procedures.....</b>	<b>15</b>
<b>Air Hose and Tool Use.....</b>	<b>16</b>
Attaching Air Hose and Tools.....	16
<b>Using Compressor for Spraying.....</b>	<b>17</b>
Moisture in Compressed Air.....	17
<b>Shutdown Procedures.....</b>	<b>17</b>
<b>STORAGE.....</b>	<b>18</b>
<b>Between-Use Storage.....</b>	<b>18</b>

Drain air receiver tank.....	18
Choose a storage location.....	18
<b>Long term storage preparation.....</b>	<b>18</b>
<b>MAINTENANCE &amp; REPAIR.....</b>	<b>19</b>
<b>MAINTENANCE SCHEDULE SUMMARY.....</b>	<b>19</b>
<b>DETAILED INSTRUCTIONS – MAINTENANCE &amp; REPAIR.....</b>	<b>19</b>
Inspect Safety/Relief Valve.....	19
Inspect Air Filter.....	19
Inspect Compressor for Air Leaks.....	19
Engine Maintenance.....	20
Change Pump Oil.....	20
Drain Receiver Tank and Inspect Tank.....	20
Check Drive Belt for Tension and Alignment.....	20
Inspect & Clean Spark Arrestor (if Equipped).....	21
Keep Compressor Clean.....	21
<b>TROUBLESHOOTING.....</b>	<b>22</b>
<b>PARTS EXPLOSION.....</b>	<b>23</b>
<b>PARTS LIST.....</b>	<b>24</b>
<b>PUMP EXPLOSION.....</b>	<b>25</b>
<b>PUMP PARTS LIST.....</b>	<b>26</b>
<b>PNEUMATIC SCHEMATIC.....</b>	<b>27</b>

## About Your Air Compressor

Thank you for purchasing a air compressor! It is designed for long life, dependability, and top performance.

**Intended Use.** It provides compressed air primarily used for operating air tools and pressurizing other non- tool objects such as tires. Special precautions are necessary when used for cleaning. It is not to be used to supply breathing air.

Note: Do not use for other purposes, as unforeseen hazards or equipment damage may result.

**Power Source.** The air compressor is powered by a gasoline engine.

**Supplies Required.** Normal operation will require you to supply:

- Compressor pump oil
- Gasoline
- Engine oil
- Personal Protection Equipment

See “*Specifications*” section of this manual for more detail.

**Site Location.** Intended for outdoor use only.

**Personal Protection.** Wear safety apparel during operation, including safety glasses with side and top protection. Ear protection is also recommended if working near any operating engine.

**Adult control only.** Only trained adults should set up and operate the air compressor. Do not let children operate.

**Under The Influence.** Never operate, or let anyone else operate, the air compressor while fatigued or under the influence of alcohol, drugs, or medication.

Keep this manual for reference and review.

### **ATTENTION: Rental Companies and Private Owners who loan this**

All persons to whom you rent/loan this air compressor must have access to and read this manual. Keep this owner's manual with the air compressor at all times and advise all persons who will operate the machine to read it. You must also provide personal instruction on how to safely set-up and operate the air compressor and remain available to answer any questions a renter/borrower might have.

## Specifications

<b>MODEL</b>	
Model #	TMG-GAC40
<b>FLOW OUTPUT</b>	
Max. Pressure Rating	175 PSI
Volume Rating @ 90 PSI	24.4 CFM
Receiver Capacity	40 gal.
<b>ENGINE</b>	
Engine	LONCIN G300EA
Engine Displacement (cc)	302 cc
<b>DIMENSIONS / COMPONENTS</b>	
Length	41"
Width	18"
Height	40"
Weight	420 lbs.
Mounting Hole Diameter	0.5"
Suggested Mounting Bolt Diameter	7/16"
<b>SUPPLIES REQUIRED (not included)</b>	
Engine Oil	Refer to engine owner's manual
Pump Oil (shipped with oil, but refills required)	SAE 30 non-detergent pump oil
Pump Oil Capacity	38 oz.

## Component Identification

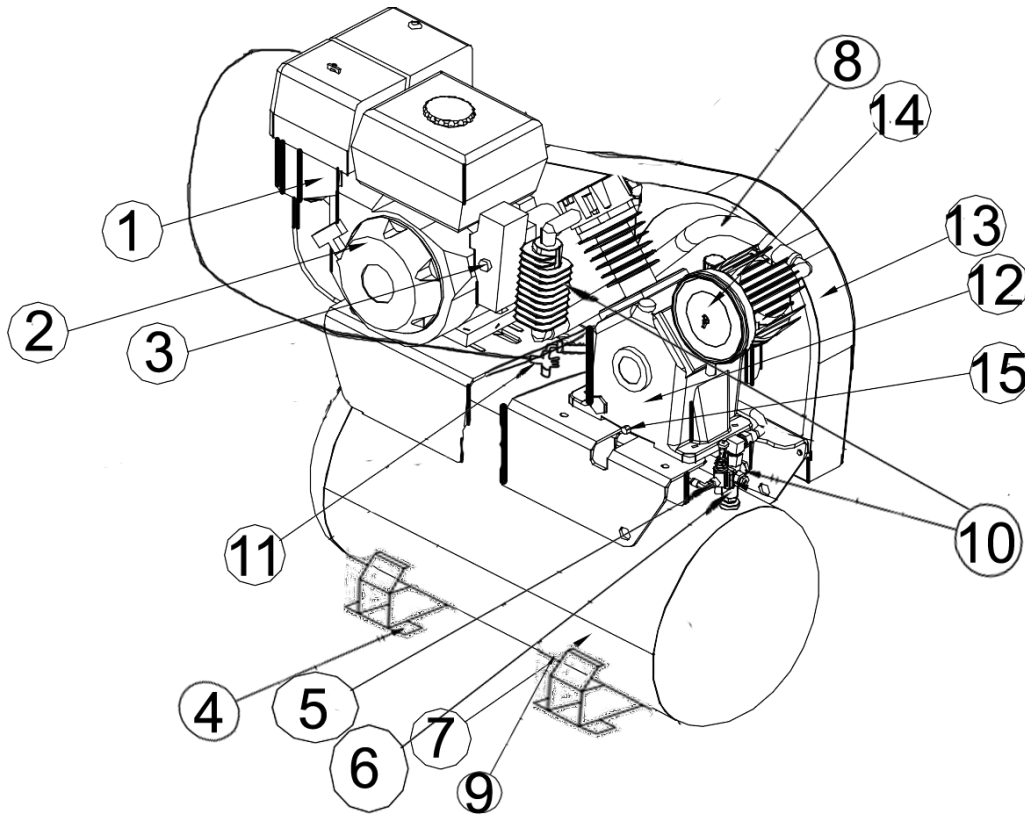

- 1. Engine Controls:** Location of choke, engine speed and fuel valve.
- 2. Engine:** NOT shipped with oil. Refer to engine Owner's Manual for proper oil and capacity.
- 3. Engine On/Off/Start Switch:** Turn switch to "ON" when using recoil to start engine. Turn switch to "START" when using electric start. CAUTION: Unit is not equipped with high temperature "auto shutoff". Do NOT allow to overheat.
- 4. Lifting Eyes:** May also be used as tie down locations.
- 5. Ball Valve:** 1/2" NPT air supply outlet. Compressed air supply point. A pressure regulator and/or quick connect fittings can attach here.
- 6. Pressure Gauge:** Liquid filled gauge. Shows pressure in receiver tank.
- 7. Air Receiver / Storage Tank:** 40 gallon tank.
- 8. Discharge Tube:** Carries compressed air from pump to safety/check valve, and then to the storage tank. It becomes very hot during use and can cause severe burns. Never touch.
- 9. Tank Drain Valve:** Used to remove moisture from air after compressor is shut off and air emptied from tank. Drain moisture daily after each use.
- 10. ASME Safety/Check Valve:** Automatically releases air if tank exceeds preset pressure max. of 180 PSI. A check valve is a pressure release port. Pull valve pin to relieve pressure from receiver tank.
- 11. Unloader:** Vents discharge air to atmosphere in start/stop operation.
- 12. Air Compressor Pump:** Shipped with oil.
- 13. Belt Guard:** Covers belt, engine pulley and flywheel. NEVER operate compressor without belt guard in place.
- 14. Compressor Air Filter:** Keep clean and particle free. See "Pump Explosion and Pump Parts List" for replacement part number.
- 15. Magnetic Oil Drain Plug:** Removal allows for drainage of oil from pump. Attracts metal particles that could damage pump.

# Safety

## Hazard Signal Word Definitions



This is the safety alert symbol. It is used to alert you to potential personal injury hazards. Obey all safety messages that follow this symbol to avoid possible injury or death.



DANGER (red) indicates a hazardous situation, which if not avoided, will result in death or serious injury.



WARNING (orange) indicates a hazardous situation, which if not avoided, could result in death or serious injury.



CAUTION (yellow), used with the safety alert symbol, indicates a hazardous situation, which if not avoided, could result in minor or moderate injury.



CAUTION (yellow), without the safety alert symbol, is used to address practices not related to personal injury.



NOTICE is used to address practices not related to personal injury.



# Safety Labeling

## Safety Decal Locations

**⚠ WARNING:**

ALWAYS make sure safety labels are in place and in good condition.

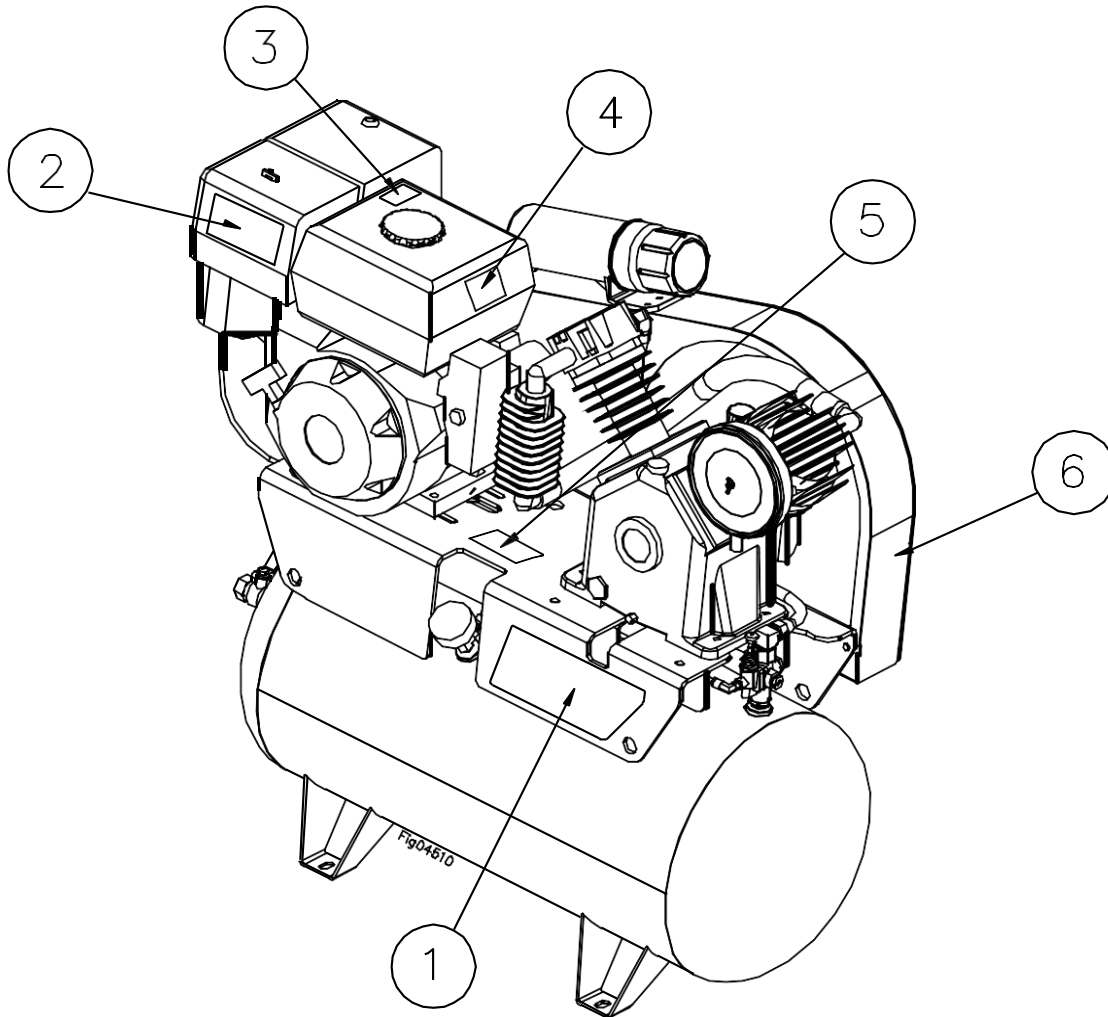

On-Product Warning Labels	
Location	Description
1	Air Compressor Instructions
2	Poisonous Gas
3	Burn Hazard, Hot Muffler
4	Fuel Fire Explosion Hazard
5	Engine Electric Start – Battery Hazard
6	Air Compressor Safety

# Safety Decals

1

<p><b>MAINTENANCE SCHEDULE</b> Read Owner's Manual for details.</p> <p><b>DAILY:</b> 1. Check oil level in pump and engine. 2. Depressurize air tank and drain water.</p> <p><b>WEEKLY:</b> 1. Inspect air filter element; clean if necessary. 2. Clean all external parts. 3. Test safety valve by pulling ring. Replace if valve does not operate freely.</p> <p><b>MONTHLY:</b> 1. Check for air leaks. 2. Inspect bolts and screws; tighten as needed. 3. Check belt for tension and wear; replace as needed.</p> <p><b>Pump Oil:</b> Change first 50 hours, then every 500 hours. <b>Engine Oil:</b> Change every 100 hours.</p> <p><small>For questions, replacement parts or labels contact product support at <a href="http://www.northstarind.com">www.northstarind.com</a> or call 1-800-276-8810.</small></p>	<p><b>OPERATING INSTRUCTIONS</b></p> <p><b>BEFORE STARTING</b> 1. Read Owner's Manual for details. 2. Always wear ear protection and ANSI Z87.1 approved safety glasses with side shields.</p> <p><b>STARTING INSTRUCTIONS</b> 1. Rotate knob to vertical on unloader to unload / relieve air pressure between tank and engine. 2. Move fuel valve lever to ON position. 3. For cold engine, move choke lever to CLOSED position. For warm engine, leave in OPEN position. 4. Turn key to ON and pull recoil, or turn key to START (for battery electric start). 5. When engine starts, gradually move choke lever to OPEN position. 6. Rotate unloader knob back to horizontal to fill air tank.</p>	<p><b>SHUT DOWN</b> 1. Turn key to OFF position. 2. Move fuel valve lever to OFF position. 3. Depressurize air tank by pulling ring on safety valve. 4. Drain water by opening drain on tank.</p>
--	---	---

2

<b>⚠ WARNING</b>	
	<p style="text-align: center;"><b>Poisonous Gas</b></p> <p>This product gives off carbon monoxide, a poisonous gas that can kill you. You CANNOT smell it, see it, or taste it.</p> <ul style="list-style-type: none"> <li>- ONLY use outside &amp; far away from windows, doors, &amp; vents.</li> <li>- NEVER use inside homes, garages, or sheds, EVEN if you run a fan or open doors or windows. See owner's manual for more details.</li> </ul>

3

<b>⚠ WARNING</b>	
	<p style="text-align: center;"><b>Burn Hazard</b></p> <p>Do not touch hot muffler. Muffler may be hot even if the unit is stopped.</p> <p>Allow unit to cool before servicing.</p>

4

<b>⚠ WARNING</b>	
	<p style="text-align: center;"><b>Fuel Fire/Explosion Hazard</b> Fuel is flammable and explosive.</p> <p>Never fuel a running or hot engine. Clean up fuel spills immediately. Ensure there are no fuel leaks before starting. Keep sources of sparks and flames away. Hot exhaust may also ignite spilled fuel. No Smoking. Keep a fire extinguisher nearby.</p>
	
	

5

<b>⚠ WARNING</b>	
<b>Engine Electric Start - Battery Hazard</b>	
<ul style="list-style-type: none"> <li>- Electric start requires a 12 volt battery to be supplied by purchaser.</li> <li>- ALWAYS follow the battery connection &amp; use procedures in the equipment or engine owner's manual.</li> <li>- A battery can explode if the correct connection &amp; use procedures are not followed, resulting in serious injuries.</li> </ul>	

6

<b>⚠ WARNING</b>	
	<p style="text-align: center;"><b>Burn Hazard</b></p> <p>Hot pump - Do not touch. Pump may be hot even if the unit is stopped. Allow unit to cool before servicing.</p>



<b>⚠ WARNING</b>	
	<p style="text-align: center;"><b>Belt Entanglement Hazard</b></p> <p>KEEP belt guard in place while machine is operating.</p>

<b>⚠ WARNING</b>	
	<p style="text-align: center;"><b>Corrosion Bursting Hazard</b></p> <p>Depressurize air tank and drain water daily after use. Rusted air tanks can rupture or explode and cause severe injury or death.</p>

<b>⚠ DANGER</b>	
<b>Breathing Air Hazard</b>	
<p>NorthStar air compressors are NOT designed to supply breathing air. NEVER breathe compressed air. It can contain carbon monoxide (CO) or other contaminants which may cause serious injury or death.</p>	

# Initial Set-Up

## Step 1. Inspect & Unpack

Upon receipt, inspect air compressor for missing or damaged parts. Verify that it is the air compressor you ordered.

See “*Component Identification*” section of this manual for a diagram of the compressor and its components.

## Step 2. Select Suitable Location

### **WARNING: Lifting hazard**

The compressor is heavy. Ensure that proper lifting equipment is available to unload and move compressor to installation site.

### **WARNING: Location hazards**

Choose a suitable site for operating your compressor to prevent possible death from carbon monoxide poisoning or injury from fire/explosion, hot surfaces or equipment tip-over.

## Outdoor Use Only

Select a suitable outdoor location:

- Where it will NOT be exposed to rain, snow, or direct sunlight.
- Where no flammable vapors, dusts, and gases are present.
- At least 7 feet away from combustible materials
- At least 20 feet from the home, away from windows, vents and air intakes, to allow proper ventilation.
- Away from other heat-generating equipment.
- Away from dusty/dirty conditions.

Positioning:

- The compressor should be mounted on a dry, firm, and level surface. It must sit level and be stabilized so it will not slide or shift during operation.
- Situate so there is adequate pulling room for starting the engine using the recoil starter. Attempting to pull at an odd angle could rip off grip cord and/or cause muscular injuries to the operator.

Airflow:

- The location should allow for adequate, unobstructed airflow for cooling and combustion air.
- Do not allow debris to accumulate or block airflow.
- Do not operate with a tarp, blanket, or cover surrounding the machine.
- Do not place any objects against or on top of the unit.

Exhaust:

### **WARNING: Exhaust modification**

Never attempt to attach ductwork to the muffler system to allow for installation inside an enclosure. This could cause heat build-up and increased exhaust back- pressure, resulting in possible exhaust leakage or damage to the compressor.

- Place the unit so that the exhaust fumes will not be directed towards people or building air intakes.
- Keep a fire extinguisher rated “ABC” nearby which is properly charged. Be familiar with its use.
- Provide battery-operated or battery back-up type carbon monoxide alarms in any structure that is in close proximity to the running compressor.
- Do not install in small, enclosed areas without an ample circulation of supply air.

### **DANGER: Carbon monoxide hazard**

Exhaust fumes from the engine contain carbon monoxide (CO), a poisonous gas you cannot see, smell, or taste. The CO generated by the engine can rapidly accumulate, even in areas that appear to be well ventilated, resulting in dangerous and fatal concentrations within minutes. NEVER run air compressor inside any enclosed or semi-enclosed spaces, including homes, garages, basements, sheds, boxes, pick-up truck beds, RVs, or boats. These spaces can trap poisonous gases, EVEN if you run a fan or open windows. If you start to feel sick, dizzy, or weak while using the air compressor, shut off the engine and get to fresh air RIGHT AWAY. See a doctor. You may have carbon monoxide poisoning.

Ideal operating temperatures:

- 40° and 100°F (4° and 37°C).

Operating Limitations:

- 15°F (-9°C) or above 125°F (52°C).

If temperatures consistently drop below 32° F (0°C), store inside a heated building. If this is not possible, protect the safety/relief and drain valves from freezing.

Note: In frequently humid areas, moisture may form in the pump and produce sludge in the oil, causing parts to wear out prematurely. Excessive moisture is likely to occur if unit is stored in an unheated area subject to large temperature changes.

Two signs of excessive humidity are external condensation on the pump when it cools down and a “milky” appearance in pump oil.

### Step 3. Mounting

1. Lift and remove the compressor from the pallet using a hoist and lifting eyes provided.
2. Situate unit in chosen location and bolt in place. Bolt it in place to prevent unit from vibrating excessively. Use metal shims under the “short” feet if necessary.
3. A rubber isolation mat or pads may be used under each mounting foot to reduce vibration.

#### Mounting on Service Vehicle

If installing unit on a service vehicle you must:

- Locate unit in an open-air environment, away from driver and passengers.
- Fasten unit securely without applying excessive stress on the receiver/storage tank. Truck beds have a tendency to flex and could cause damage to the receiver tank if fastened directly to the truck bed. It is the user’s responsibility to provide an adequate means of fastening the unit in these applications.
- Direct exhaust and other hot parts of compressor away from the cab or flammable equipment. Make sure the exhaust clears the side of the bed.
- Securely close (and preferably drain) gas tank to prevent fuel leakage during transportation.

#### Installing Discharge Piping

If installing discharge piping you must:

- Adhere to all local building codes.
- Use discharge piping of the same diameter as the compressor discharge connection.
- Use pipe, tube, hose, or distribution components rated for use with compressed air and maximum pressure of this compressor.
- Use a properly rated flexible connection between the tank and discharge piping.

#### WARNING: Burst hazard

Do not use plastic (PVC) pipe, rubber hose, copper, or lead-tin soldered joints anywhere in the compressed air system.

### Step 4. Electrical Starting: Battery Procedure

In addition to the recoil starter, the engine is capable of electric starting which, if used, will require the purchaser to provide a hook-up to an external 12-volt size battery. Battery should have a minimum rating of 18 amp-hour. You may also choose to use a “jump” from a service

vehicle’s battery or an external battery set on the ground.

See engine Owner’s Manual for more information regarding battery cable size and length recommendations.

Follow instructions below for connecting and disconnecting the battery. After starting engine, a battery is not required, but can remain connected without damaging the compressor.

#### WARNING: Battery hazards

Batteries contain caustic acid, can emit explosive gases, and can cause electric shock. Caution must be exercised when making connections to a battery to avoid shock, contact with acid, and prevent any sparking that could lead to an explosion.

**Eye/skin protection.** Always wear eye protection and protective clothing when connecting or disconnecting battery.

**Electric shock Prevention.** Never touch both battery terminals at the same time with your hand or any non- insulated tools.

**Acid/skin contact.** If battery acid contacts skin or clothing, flush immediately with water and neutralize with baking soda.

#### Battery Connection

Always connect the cables in the following sequence to avoid possible shock.

1. Connect one end of the **red** (+) cable to compressor engine’s starter solenoid terminal.

Note: Access to the solenoid terminal is from the top may require reaching between the gasoline tank and shroud covering the compressor’s cooling fan.

2. Connect one end of the **black** (-) cable to compressor engine’s mounting bolt, frame bolt, or other good engine ground connection.
3. Connect other end of the **red** (+) cable to battery positive (+) terminal.
4. Connect other end of the **black** (-) cable to battery negative (-) terminal as shown.
5. Coat terminals and cable ends with grease if they are to remain permanently connected.

#### CAUTION: Battery connection

Be careful not to connect the battery in reverse polarity, as this will short circuit the battery charging system. Since the engine has not yet been grounded to the battery ground, your uninsulated tool handles can cause a short circuit if they also touch a grounded part while tightening the positive battery cable end.

## Battery Disconnection

Once operating, the compressor will continue to run whether the battery is connected or not. It can be disconnected while the compressor is running. The battery should be disconnected from the engine when the compressor is not going to be used for a long period of time. Always disconnect cables in this reverse sequence to the above connection sequence .

1. First, disconnect the **black** (-) cable from the battery negative (-) terminal.
2. Next, disconnect the **red** cable from the battery positive (+) terminal.
3. Disconnect the **black** (-) cable from the grounding connection.
4. Disconnect the **red** (+) cable from the starter solenoid terminal.

## Install Spark Arrestor (if Required)

Equip engine with spark arrestor if machine will be used near any ignitable forest, brush, or grassy land. (See engine Owner's Manual provided to determine if the engine is already equipped.) Make sure you comply with applicable local, state, and federal codes.

# Operation

## Follow Safety Rules for Operation

Before starting the compressor, review the safety rules found below and throughout the manual.

### **⚠ WARNING**

Failure to follow safety rules may result in serious injury or death to the operator or bystanders.

**Instruct operators.** Owner must instruct all operators in safe set-up and operation. Do not allow anyone to operate the compressor who has not read the Owner's Manual and been instructed on its safe use.

**Safety equipment/controls.** Always operate with all safety covers, guards, and barriers in place and in good working order, and all controls properly adjusted for safe operation.

**Moving parts.** Keep hands, feet, hair and apparel away from moving parts. Air vents may cover moving parts and should be avoided as well. Never remove any guards while the unit is operating.

**Ear Protection.** Hearing can be damaged from prolonged, close-range exposure to the type of noise produced by this compressor. The use of ear plugs or other hearing protection device is recommended for persons working within 15-20 feet of the running compressor for an extended period of time.

**Eye Protection.** Wear ANSI/OSHA required "Z87.1" safety glasses when operating or servicing the compressor. Pressurized air spray from this unit can cause severe injury to the eyes. Small objects can become airborne as the air spray contacts them.

**Respirator.** Always wear a respirator when spraying and spray in a well-ventilated area to prevent health and fire hazards.

## Preparing for Operation

Make sure that any regular maintenance has been performed as prescribed in "Maintenance & Repair" section.

1. Refer to the engine Owner's Manual for engine maintenance instructions.
2. Drain receiver tank of any moisture.
3. Inspect for oil leaks.
4. Check for any unusual noise/vibration.
5. Ensure the area around compressor is free from rags, tools, debris and flammable or explosive materials.

6. Ensure belt guards and covers are securely in place.

### **⚠ WARNING: Entanglement hazard**

Do NOT operate with protective covers or guards removed. Doing so could expose high speed moving components which could allow for the operator or bystanders to become entangled. Entanglement in this equipment may result in serious injury, amputation or death.

## Check/Add Oil to the Engine and Pump

Check the oil levels in the engine and pump. Use dipstick for engine oil level and sight glass for pump oil level. Add oil as needed. A low oil shutdown feature prevents the engine from starting without sufficient oil.

Engine: See engine Owner's Manual for capacity and recommended oil type for your expected ambient conditions.

### **⚠ WARNING: Burn hazard**

Never open oil port while compressor is running. Hot oil can spray over face and body.

### **⚠ CAUTION: Inadequate lubrication**

Never operate compressor with inadequate lubricant. This will cause overheating and severe damage to the engine and pump.

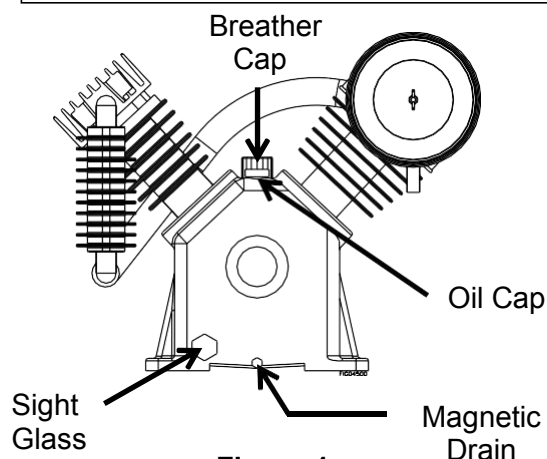

Figure 1

Pump: The compressor pump capacity is 38 oz. Use SAE 30 non-detergent pump oil prior to break-in. You may use synthetic lubricants after 50 hour break-in. See "Appendix A: Lubricants and Compatibility" for a list of suitable and alternative lubricants.

### CAUTION: Synthetic lubrication hazard

If you will be using a synthetic lubricant, all downstream piping material and system components must be compatible.

## Check and Fill Gasoline Tank

- Check the gasoline level in the engine's tank.
- Fill tank outdoors with fresh unleaded gasoline from a portable container.
- Never pump fuel directly into engine at gas station. Static charge can build and ignite fuel.
- Use a UL approved fuel container to transfer gas to the engine.
- Always place container on ground to be filled. Keep nozzle in contact with container while adding fuel.

### ⚠ WARNING: Fire/Explosion hazard

Gasoline is highly flammable and explosive. Heat, sparks, and flames can ignite gasoline vapors, which can become widespread during fueling. A flash fire and/or explosion could result and cause serious injury or death. Use extreme care when handling gasoline. Carefully follow all the instructions in this section to avoid the following conditions which could result in gasoline ignition:

- gas vapor collection inside enclosures
- static electric sparks
- sparks from electric wiring, batteries, or running engines
- sources of heat (such as a hot engine or exhaust)
- open flames, including pilot lights
- smoking

## To Fill Gas Tank:

1. Before removing fuel cap, make sure compressor has been off and allowed to cool for at least 2 minutes.

### ⚠ WARNING: Hot engine hazard

A running engine is hot enough to ignite fuel. Never add fuel or remove gas cap if engine is running or still hot. Let cool at least 2 minutes.

2. Remove fuel cap.
3. Add gas through the fill opening. Do not overfill. Allow at least ½" of empty space below fill neck to allow for gas expansion.
4. Replace fuel cap securely before starting engine.
5. Clean up fuel spills/splashes immediately.
  - If possible, move machine away from spilled gas on the ground.
  - Wipe up spilled gas and wait 5 minutes for excess gas to evaporate before starting engine.
  - Gas-soaked rags are flammable and should be disposed of properly.

- If gas is spilled on your skin or clothes, change clothes and wash skin immediately.
6. Store extra gas in a cool, dry place in a UL- approved, tightly sealed container.



## Inspect Fuel System/Check for Leaks

Inspect fuel system for leaks BEFORE starting compressor. Look for:

- Signs of leaks or deterioration
- Chafed or spongy fuel hose
- Loose connections
- Loose or missing fuel hose clamps
- Damaged gasoline tank
- Selective gasoline shut-off valve

Do not start compressor until all needed repairs have been completed.

## Start-Up Procedures

### CAUTION: Break-in period

Before initial use, open the ball valve and run the compressor for 20 minutes to

1. Before Starting:
  - Drain storage tank and close drain valve.
2. Turn the unloader to the engine START position. (Figure 2)

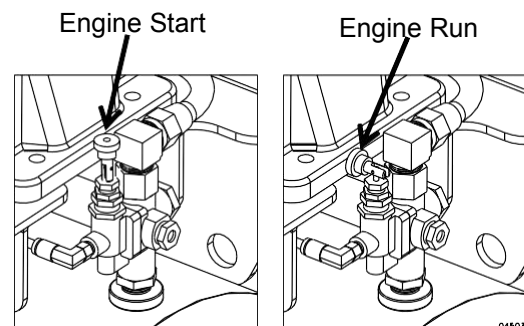

Figure2

3. Starting engine. (See the engine manual for more details.)
  - a. Move fuel valve lever to the ON position.
  - b. For a cold engine, move choke lever to the CLOSED position. For a warm engine, leave in OPEN position.
  - c. Turn engine switch to ON position.
  - d. Grab the recoil starter grip and rapidly pull out the starter cord. Allow starter cord to return slowly.
4. When engine starts, gradually move choke lever to OPEN position.
5. After engine has started, move the unloader to the engine RUN position.
6. The compressor is now ready to use.
7. The unloader will maintain pressure in the tank between 145 to 175 PSI.
8. Under long, continuous-run operating conditions, be prepared to:
  - Check and refuel on a regular basis. See engine Owner's Manual for more detail.
  - Check engine oil level each time you refuel.

**⚠ WARNING: Overheating**

This compressor is not equipped with "auto shut off". Do not allow to overheat. Failure to allow adequate ventilation or restrict the air flow may cause the machine to overheat.

**⚠ WARNING: Inflatables/Low PSI tire**

Never use compressor to inflate small low-pressure objects, i.e., balloons/inflatables, small or low volume PSI tires. It is easy to over-pressurize them, causing them to rupture. Use a gauge to check the pressure regularly. Observe the inflation capacity of the object prior to filling with air.

**⚠ WARNING: Bursting hazard**

Too much air pressure causes a hazardous risk of bursting. Check the manufacturer's maximum pressure rating for air tools and accessories. The outlet pressure must never exceed the maximum pressure rating.

## Air Hose and Tool Use

**Pressure control related devices.** Never remove, adjust, bypass, change, modify or make substitutions for safety/relief valves, pressure switches or other pressure control related devices. Over-pressurization of the compressor could result and cause explosion.

**⚠ WARNING**

NEVER over-pressurize the receiver tank or air tools beyond nameplate capacity. Do not operate the unit at pressures, temperatures or rotational speeds in excess of manufacturer's recommendations. Be sure all accessory equipment and system components meets or exceeds the pressures and temperatures developed by the unit. Exceeding the pressure rating could cause them to explode or fly apart.

- Compressor and any tools must be sized properly- consider the maximum pressure requirements and air volume of each. (Maximum operating pressure of your compressor and volume rating is listed in "Specifications" section of this manual.)
- Inspect hoses for holes or rupture points.
- Ensure the switch is in the OFF position and tank pressure gauge reads zero before changing air tools or disconnecting hose from air outlet. Failure to do so could result in personal injury.
- NEVER use air tools or attachments without first determining the maximum pressure recommended for that equipment.

**⚠ CAUTION: Incompatible component hazard**

Do not operate this unit with any components rated less than the maximum operating pressure of the unit (175 PSI) unless a regulator limiting pressure is used.

Note: Many tools are rated for only 90 PSI. It is acceptable to use a tool rated for 90 PSI when max. pressure of compressor is 175 ONLY if a regulator is used and the regulated pressure is 90 PSI or less.

- When using high-pressure tools, make sure the tool is properly coupled, user is wearing protective equipment, and there are no persons nearby.

## Attaching Air Hose and Tools

**⚠ CAUTION: Air tools hazard**

Do not attach air tools to open end of the hose until start-up is completed and the unit checks out OK.

1. Connect air hose to ball valve outlet.
2. Connect tool to other end of the hose.
3. Keep fingers off trigger of tool until ready to use. A tool has power when compressor has air.
4. Ensure connections are tight/secure. Firmly grasp hose in hand when connecting or disconnecting to prevent hose whip. An improperly seated coupler can blow off the machine when started.



**⚠ WARNING: High pressure stream**

Never direct air stream at people or animals. A high- pressure stream produced by this compressor could pierce the skin and underlying tissues, leading to a serious injury or amputation. **DO NOT TREAT AN INJECTION INJURY AS A SIMPLE CUT!** In case of skin injection, see a physician immediately.

Note: To change tools or attachments, change out the tools on the end of the hose. There is a check valve built into the hose coupler so that air does not escape when tools are removed.

**⚠ WARNING: Projectile hazard**

Never disconnect threaded joints with pressure in the tank. Removing threaded connections with pressure in the tank may cause the removed component to become a projectile.

- Do not string hoses across floors or aisles where they are liable to cause personnel to trip and fall. Suspend air supply hoses overhead, or otherwise locate to provide sufficient access and protection against damage.

## Using Compressor for Spraying

**Spraying flammable materials.** Always follow precautions on container labels or MSDS' before spraying flammable materials such as paint.

### Moisture in Compressed Air

Moisture in compressed air will form into droplets as it leaves air compressor pump. When humidity is high or when a compressor is in continuous use for an extended period of time, this moisture will collect in the tank.

When using a paint spray or sandblast gun, this water will be carried from the tank through the hose, and out of the gun as droplets mixed with the spray material. If this is not acceptable for your application, an external air dryer must be added to the system.

## Shutdown Procedures

### Normal Shutdown

1. Move the pressure switch lever to OFF and close the ball valve to stop/shut off air flow.
2. Turn engine switch to OFF position.

3. Turn fuel valve lever to OFF position.
4. Drain air from the tank by releasing pressure. Disconnect hoses and open the ball valve or pull the ring on the safety relief valve.

Note: Lifting the unloader knob will not release pressure from the tank.

5. Once the air tank pressure gauge registers under 10 PSI, open the drain valve on the foot ring of the tank to drain any moisture.
6. Remove spark plug to prevent accidental starting of engine.
7. Cool engine at least 5 minutes before storing. A hot engine is a fire hazard. (See "Storage" section for more information.)

### Malfunction during operation.

Immediately turn off the compressor if any of the following conditions arise during operation:

- Excessive change in motor speed, slow or fast
- Overheating
- Excessive vibration
- Unusual noise
- Flame or smoke
- Air leakage

To stop the compressor in an emergency:

1. Move the pressure switch lever to OFF and close the ball valve to stop/shut off air flow.
2. Turn engine switch to OFF position.
3. Turn fuel valve lever to OFF position.
4. Pull the safety relief valve to quickly release pressure from the tank.
5. Remove spark plug to prevent accidental starting of engine.
6. Ensure compressor will not be re-started until problem is remedied.

**⚠ WARNING: Shutdown hazards**

Do not leave an operating machine unattended. Always shut the machine OFF and relieve the pressure before leaving the machine. **NEVER** disconnect the high- pressure hose from the unit while the tank and air line is pressurized.

# Storage

When you are finished using the compressor, you must:

- Make sure the compressor is shut down and all tools are disconnected. (See “Shutdown” section.)
- Drain air receiver tank.
- Store the compressor properly.

Detailed instructions are provided below.

## Between-Use Storage

Before storing, let engine cool for at least 5 minutes, as a hot engine is a fire hazard. When machine is not in use, remove spark plug to prevent unintentional starting or operation by untrained persons.

## Drain air receiver tank

### **WARNING: Risk of bursting**

Drain air receiver tank daily or after each use to prevent moisture buildup in the air tank. Serious injury or death may occur from a tank explosion if air tanks are not properly maintained.

To prevent tank corrosion, drain the receiver tank after each days use.

Draining the tank will:

- Dry out any moisture that has accumulated in the tank. Leftover moisture can cause tank corrosion and premature failure.
- Ensure that the unit is operating properly should it be needed in an emergency.

To drain the tank:

1. Reduce tank pressure below 10 PSI by disconnecting the hoses and opening the ball valve, or pulling the ring on the safety relief valve.

Note: Lifting the unloader knob will NOT release pressure from the tank.

2. Drain moisture from tank by opening the drain valve located at the bottom of the tank.

## Choose a storage location

An appropriate storage location is:

- Clean and dry
- Away from sources of heat, open flames, sparks, or pilot lights, even if gas tank is empty. Residual gasoline could ignite.
- Away from extreme high or low temperatures.

## Long term storage preparation

Prepare engine for long-term storage if you will not be using machine again for more than 30 days. Fuel can become stale when stored over 30 days. Stale fuel causes acid and gum deposits to form in the fuel system which can cause engine malfunction. You have two options:

a. Remove all gasoline from the tank and carburetor

**OR**

b. Add fuel stabilizer to the gasoline following manufacturer's instructions:

1. Ensure gas tank is full.
2. Add fuel stabilizer to fuel tank.
3. Run engine outdoors at least 10 minutes after adding stabilizer to allow it to enter the fuel system.
4. Shut off engine.
5. Disconnect spark plug wire and remove spark plug.
6. Add one teaspoon of oil through spark plug hole.
7. Place rag over spark plug hole and pull the recoil a few times to lubricate the combustion chamber.
8. Replace spark plug, but do not reconnect the spark plug wire.
9. Pull the recoil slowly until resistance is felt and the notch on the recoil aligns with the hole at the top of the recoil starter cover. This will close the valves so moisture cannot enter the engine cylinder. Return the recoil gently.

# Maintenance & Repair

## **WARNING: Maintenance hazards**

ALWAYS shut off the engine, disconnect the spark plug wire from spark plug and release air pressure from the receiver tank before cleaning, adjusting, or servicing the compressor. Make sure all guards and shields are replaced before re-starting.

## Maintenance Schedule Summary

Item	Frequency
Inspect safety/relief valves	Weekly
Check pump oil level	Weekly
Inspect air filter	<ul style="list-style-type: none"><li>• Weekly</li><li>• Replace every 12 months or 1000 hours of use</li></ul>
Inspect for air leaks	Monthly
Engine maintenance	See engine Owner's Manual <ul style="list-style-type: none"><li>• Change oil: after first 20 hours of use</li><li>• Every 100 hours of use after that</li></ul>
Change pump oil/ Clean magnetic drain plug	<ul style="list-style-type: none"><li>• After first 50 hours of use</li><li>• Every 3 months or 500 hours of use after that</li></ul>
Inspect & drain receiver tank	Daily
Check drive belt tension and alignment	Monthly
Inspect & clean spark arrestor (if equipped)	See manufacturer's instructions
Dust/debris removal	Monthly

See detailed instructions for each maintenance item below.

## Detailed Instructions – Maintenance &

### NOTICE

Dispose of used motor and pump oil in a manner that is compatible with the environment and in accordance with local, state, and federal laws and regulations.

- Take used oil in a sealed container to your local recycling center or service station for reclamation.
- Do not throw it in the trash, pour it on the ground, or pour it down a drain.

**No modifications.** Never modify or alter the compressor in any way. Modifications can create serious safety hazards and will also void the warranty.

### Inspect Safety/Relief Valve

This valve should be inspected on a weekly basis if used regularly or the first time it is being used after a prolonged period of storage. The safety valve automatically releases air if the tank pressure exceeds the preset maximum.

- Check the safety/relief valve by pulling the rings.
- Replace safety/relief valve that do not operate freely.

### **WARNING: Safety/Relief valve**

If the safety/relief valve does not work properly, over-pressurization may occur causing air tank rupture or explosion. Occasionally pull the ring on the safety valve to make sure the safety valve operates freely. If the valve is stuck or does not operate smoothly, it must be replaced with a valve having the same pressure rating.

### Inspect Air Filter

Inspect the compressor's air filter element on a weekly basis if used regularly or the first time it is being used after a prolonged period of no use. A dirty air filter will not allow the air compressor to operate at full capacity.

- Clean air filter when necessary.
- Every 12 months or 1000 hours, replace the air filter.

Note: Keep the air filter clean. Do not operate with the air filter removed.

### Inspect Compressor for Air Leaks

Inspect system for air leaks on a monthly basis, or again, at the first use after a prolonged period of storage.

- Squirt soapy water around joints during compressor operation and watch for bubbles. Developing bubbles indicate a leak is present.
- Tighten fittings if necessary.

### Engine Maintenance

Perform engine maintenance as specified in the engine Owner's Manual. Items include:

- Change oil after the first 20 operating hours, and at least every 100 operating hours thereafter and oil filter, as directed in engine Owner's Manual.

#### **⚠ WARNING: Burn hazard**

Never open oil port while engine is running. Hot oil can spray over face and body.

- Air filter check/replacement
- Spark plug cleaning/replacement
- Fuel filter check/replacement
- Fuel tank cleaning

### Change Pump Oil

After the first 50 hours of use then every 3 months or 500 hours, change pump oil while crankcase is still warm. (See "Appendix A: Lubricants" for suitable alternatives.)

1. Remove the oil fill and drain plugs. Collect the oil in a suitable container.
2. Replace the oil drain plug and refill compressor crankcase with clean oil.
3. Replace the oil fill plug.
4. Start the unit and run for several minutes. Shut down the air compressor and recheck the oil level. If necessary, add more oil. (Figure 3)

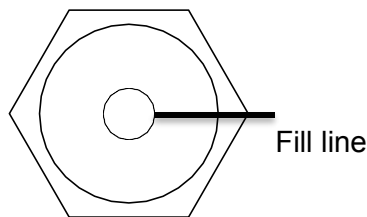

**Figure 3**

### Drain Receiver Tank and Inspect Tank

Drain water from the receiver tank daily. Water left in the tank can cause the tank to weaken and corrode, increasing the risk of tank rupture. Badly rusted receiver tanks must be replaced.

Recommends a tank inspection after every 2 years of service. See "Inspection of Unfired Pressure Vessels," volumes 2-9, August 2001, Bill McStraw (available on-line at NTIS)."

#### **⚠ WARNING: Air tank hazards**

Failure to replace a rusted air receiver tank could result in tank rupture or explosion, which could cause substantial property damage, severe personal injury, or death. Never modify or repair a tank.

### Check Drive Belt for Tension and Alignment

#### **⚠ CAUTION: Pulley/sheave hazard**

Improper pulley/sheave alignment and belt tension can result in motor overload, excessive vibration, and premature belt and/or bearing failure. To prevent this from happening, check the pulley/sheave alignment and belt tension on a regular basis.

Belts will stretch from normal use. When properly adjusted, a 5 lb. force applied to the belt between the engine pulley and the pump will deflect the about 1/2".

To align and adjust drive belt tension:

1. Remove the belt guard cover.
2. Loosen the four fasteners holding the engine to the compressor.
3. Shift the engine in the proper direction. The belt must be properly aligned when adjustment is made.
4. To align belt, lay a straight edge against the face of the flywheel touching the rim at two places. (Figure 4)

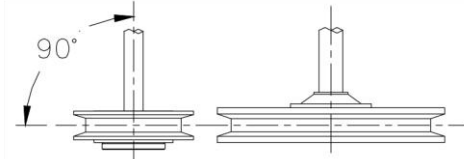

**Figure 4**

5. Adjust flywheel or engine pulley so that the belt runs parallel to the straight edge.
6. If necessary, use a gear puller to move the pulley on the motor shaft. Tighten set screw after pulley is positioned.
7. Check for proper belt tension. (Figure 5)

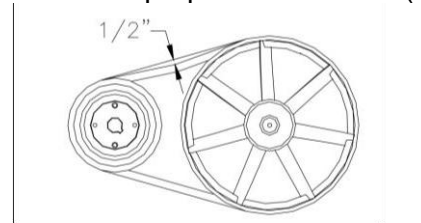

00882

**Figure 5**

8. Tighten the four fasteners holding the engine to the top plate while tension and alignment is maintained.

9. Attach the belt guard cover.

**Inspect & Clean Spark Arrestor (if Equipped)** Equip engine with spark arrestor if machine will be used near any ignitable forest, brush, or grassy land. (See engine Owner's Manual provided to determine if the engine is already equipped.) Make sure you comply with applicable local, state, and federal codes.

If the engine is equipped with a spark arrester, clean and inspect it regularly following manufacturer's service instructions. Replace if damaged.

## Keep Compressor Clean

Do not allow air intakes to become blocked. If dust or debris accumulates in the compressor, clean the compressor with a damp cloth or soft bristle brush.

Note: Do not spray compressor with a garden hose or pressure washer. Water may enter the compressor and cause damage to the engine and pump.

### IMPORTANT

If a part needs replacement, only use parts that meet the manufacturer's part number specifications.

Replacement parts that do not meet specifications may result in a safety hazard or poor operation of the compressor. Major service, including installation or replacement of parts, should be made by a qualified electrical service technician.

# Troubleshooting

This section provides a list of the more frequently encountered compressor malfunctions, their causes and corrective actions. Some corrective actions can be performed by the operator or maintenance personnel, and others may require assistance of a Service Center.

PROBLEM	POSSIBLE CAUSE
Engine does not start.	A,B,C,D,E
Air delivery drops off.	H, I, J, L, M, N, P
Compressor does not come up to speed.	F, G, J, K
Compressor is slow to come up to speed.	F, G, J, K, L
Compressor will not unload cycle.	H, L, N, P
Compressor will not unload when stopped.	H, L, N, P
Excessive starting or stopping.	N, Q, S
Moisture in crankcase, "milky" substance in oil.	R
Oil in discharge air.	T
Safety/relief valve "pops".	L, M, N
Low interstage pressure.	W
High interstage pressure.	V

POSSIBLE CAUSE	POSSIBLE SOLUTION
A.) Low Oil Shutdown	Fill engine with the adequate amount of oil.
B.) Cold Engine	Choke engine to start.
C.) No Fuel	Add gas to engine. Make sure fuel shutoff valve is open.
D.) Engine not turned ON	Place ON/OFF switch in the ON position.
E.) Spark plug wire not attached	Attach spark plug wire to spark plug.
F.) Compressor viscosity too high for ambient temperature	Drain existing lubricant and refill with proper lubricant.
G.) Belt tension too tight or sheaves not aligned	Check tension/ alignment.
H.) Air leaks in discharge piping	Check tubing connections, Tighten joints or replace as required.
I.) Compressor components leaky, broken, loose	Inspect components. Clean or replace as required.
J.) Loose flywheel or engine pulley, excessive end play in engine shaft or loose drive belts	Check flywheel, engine pulley, crankshaft drive belt tension/alignment. Replace or repair as required.
K.) Leaking check valve or check valve seat blown out	Replace check valve.
L.) Clogged or dirty inlet and/or discharge line	Clean or replace.
M.) Defective safety/relief valve	Replace.
N.) Unloader leaks or does not work	Realign stem or replace.
O.) Inadequate ventilation around flywheel	Relocate compressor for better air flow.
P.) Leaking, broken or worn inlet unloader parts at check valve	Inspect parts and replace as required.
Q.) Excessive condensation in receiver tank	Drain receiver tank.
R.) Detergent lubricant in crankcase.	Replace with proper lubricant.
S.) Light duty cycle	Increase duty cycle.
T.) Lubricant level too high	Drain excess lubricant.
U.) Worn cylinder finish	Deglaze cylinder with 180 grit flex-hone.
V.) Low pressure inlet valve leaking	Inspect, clean or repair as required.
W.) High pressure inlet valve leaking	Inspect, clean or repair as required.

# Parts Explosion

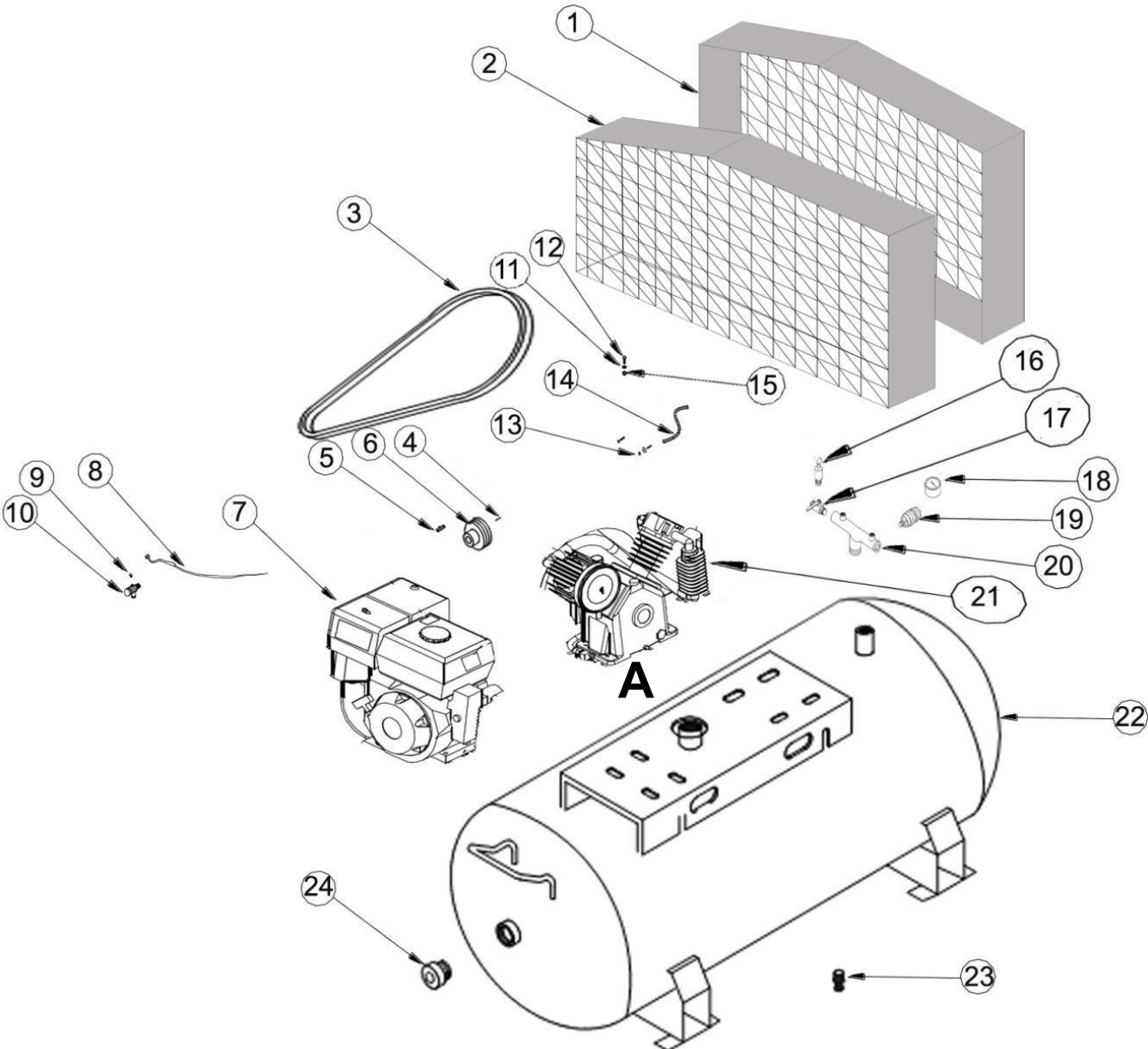

## Parts List

Ref#	Description	Qty
1	Belt Guard Cover	1
2	Belt Guard	1
3	Belt, B69	2
4	M6X30 Screw	1
5	Shaft Pin	1
6	Sheave	1
7	Gas Engine	1
8	Unloader Tube	1
9	1/2" NPT Elbow	1
10	Check valve	1
11	Washer	1
12	Bolt M10X60	1
13	Spring Washer	1
14	High Pressure Pipe	1
15	Nuts	1
16	Safety Valve, ASME 180PSI	2
17	1/2" Ball Valve	1
18	Pressure Gauge	1
19	1/4" NPT Quick Connector	1
20	5-Way Connector	1
21	Pump (A)	1
22	40 Gallon Tank	1
23	Tank Drain Valve	1
24	Plug	2



# Pump Explosion--(A)

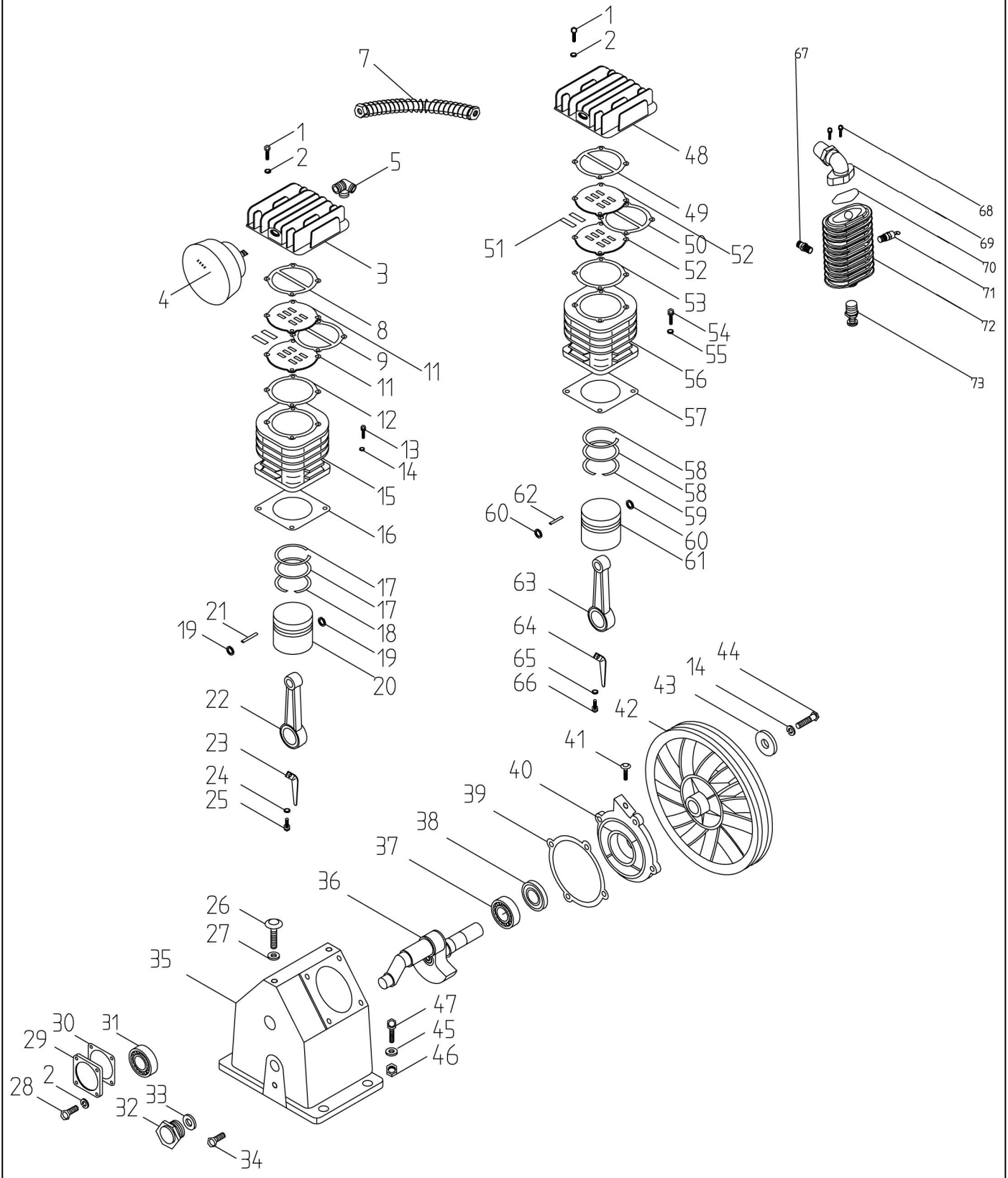

## Pump Parts List--(A)

Ref#	Description	Qty	Ref#	Description	Qty
A-1	Bolt	6	A-38	Oil Seal	1
A-2	Washer	10	A-39	Rear Bearing Seat Gasket	1
A-3	Cylinder	1	A-40	Rear Bearing Seat	1
A-4	Air Filter	1	A-41	Bolt	6
A-5	Exhaust Elbow	2	A-42	Balanced Pulley	1
A-6	Cooler	1	A-43	Plate Washer	1
A-7	Exhaust Tube	1	A-44	Bolt	1
A-8	Cylinder Head Gasket	1	A-45	Washer	4
A-9	Valve Assembly	1	A-46	Nuts	4
A-10	Valve Block	1	A-47	Bolt	4
A-11	Valve Seat Gasket	2	A-48	Cylinder Head	1
A-12	Paper Washer	1	A-49	Cylinder Head Gasket	1
A-13	Bolt	4	A-50	Valve Assembly	1
A-14	Washer	5	A-51	Valve Block	1
A-15	Cylinder	1	A-52	Valve Seat Gasket	2
A-16	Paper Washer	1	A-53	Paper Washer	1
A-17	Piston Aie Ring	1	A-54	Bolt	4
A-18	Piston Oil Ring	2	A-55	Washer	5
A-19	Clip Spring	1	A-56	Cylinder	1
A-20	Piston	1	A-57	Paper Washer	1
A-21	Piston Pin	1	A-58	Piston Aie Ring	1
A-22	Rod	1	A-59	Piston Oil Ring	2
A-23	Grease Needle	1	A-60	Clip Spring	1
A-24	Washer	1	A-61	Piston	1
A-25	Bolt	1	A-62	Piston Pin	1
A-26	Oil Filling Plug	1	A-63	Rod	1
A-27	O-Ring	1	A-64	Grease Needle	1
A-28	Bolt	1	A-65	Washer	1
A-29	Front Cover	1	A-66	Bolt	1
A-30	Front Bearing Seat	1	A-67	Double Connect	1
A-31	Gasket	1	A-68	Bolt	2
A-32	Bearing	1	A-69	Elbow	1
A-33	Oil Grass	1	A-70	Paper Washer	1
A-34	Washer	1	A-71	Safety Valve, 1/4,ASME 180PSI	1
A-35	Crankcase	1	A-72	Cooler	1
A-36	Crank Shaft	1	A-73	Drain Valve for Cooler	1
A-37	Bearing	1			

# Pneumatic Schematic

