

70' X 100' DUAL TRUSS PRO SERIES STORAGE SHELTER

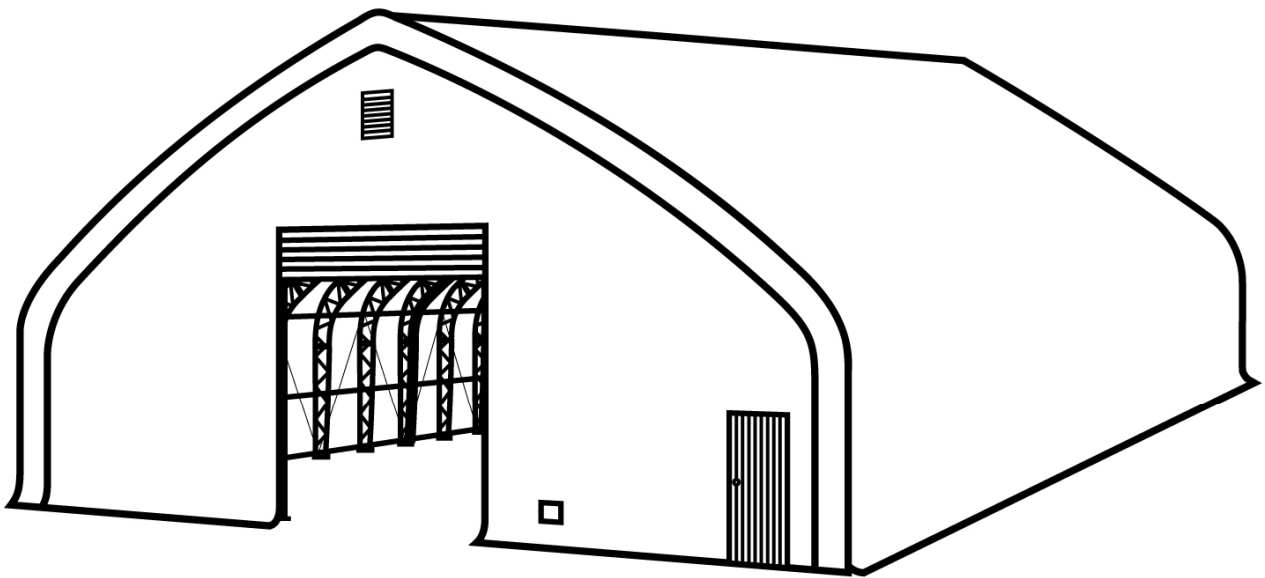

This structure is intended for temporary outdoor storage use only. It is not designed to withstand heavy snow and wind loads and does not come with engineering drawings. To ensure suitability for your specific weather needs, it is your responsibility to verify their appropriateness for your intended use and local weather conditions, especially in areas prone to severe weather.

- Please read and understand the product manual completely before assembly
- Check against the parts list to make sure all parts are received
- Wear proper safety goggles or other protective gears while in assembly
- Do not return the product to dealer. They are not equipped to handle your requests.

Missing parts or have questions on assembly?

Please call: 1-877-761-2819 or email: cs@tmgindustrial.com

MAIN SPECIFICATIONS :

- Assembly size : W21.35 x L30 x H8.5 (m) / 69.9ft x 98.4ft x 27.9ft
- Outside width : 21.35m / 70ft, inside width : 20.3m / 66.6ft, length : 30m / 98.4ft
- Ridge peak height : 8.5m / 27.9ft
- Peak clearance height : 8m / 26.2ft
- Roll up door : 5.5 x 4.88 (m) / 18ft x 16ft
- Shoulder wall clearance height : 3.6m / 11.8ft

CONCRETE FOUNDATION SIZE SEE BELOW FIGURE.

- The layout of foundation (one).

Depth of cement

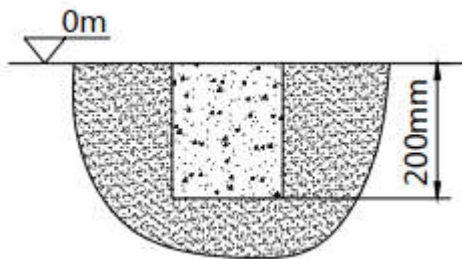

Unit: mm (ft)

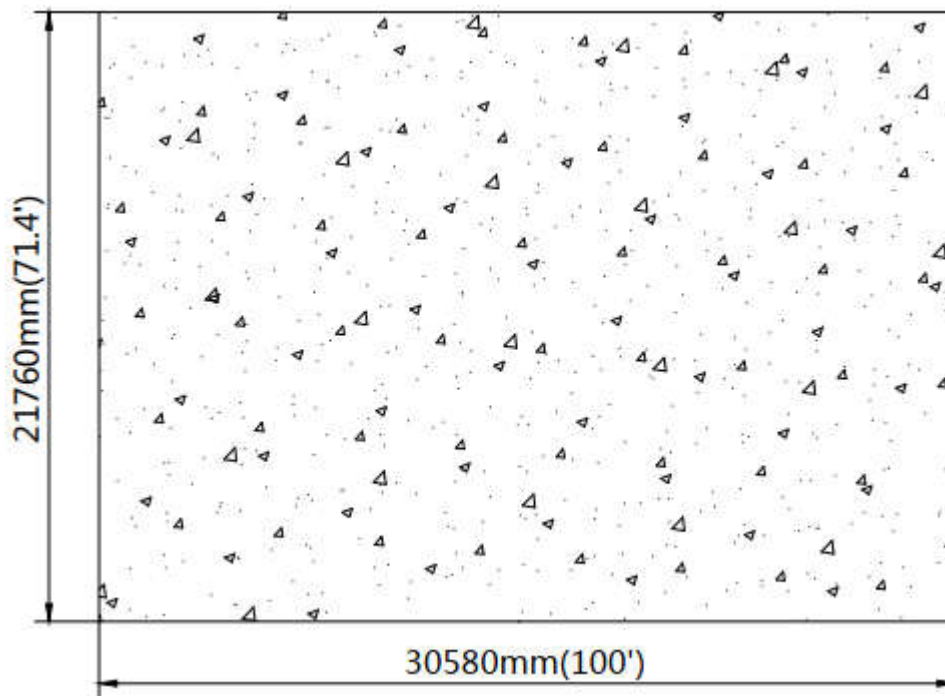

- The layout of foundation (two).

Note : the ground anchor is installed on the cement block.

Depth of cement

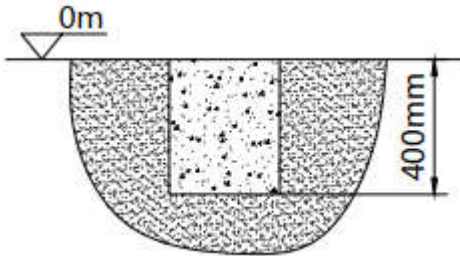

Unit: mm (ft)

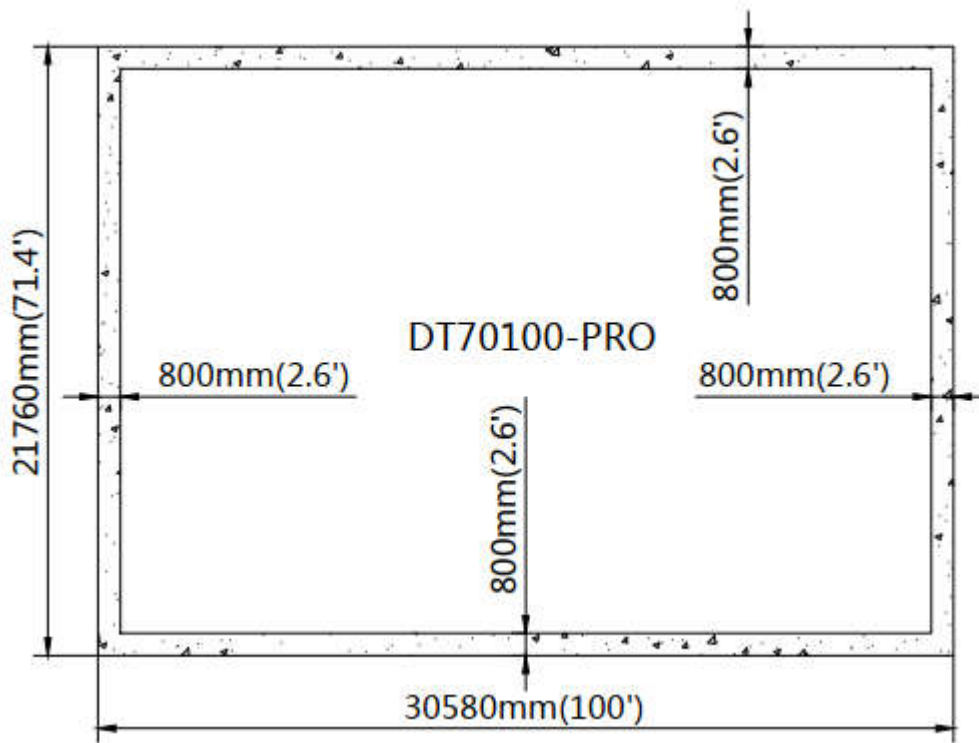

- Baseplate layout.

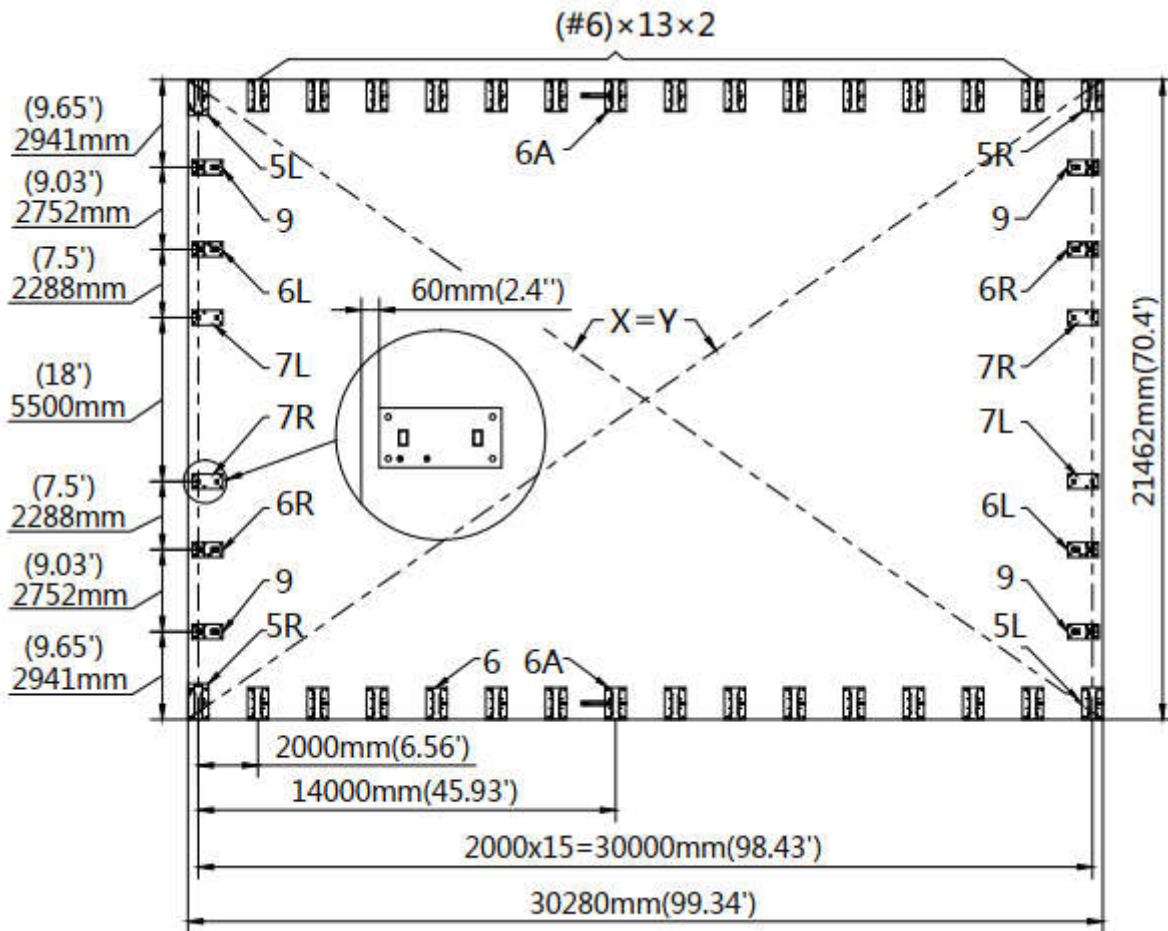

PRIOR TO ASSEMBLY

Please go through the whole instruction manual completely. It is very important to follow your local safety regulations and industry standards during installation. Regulations may include but are not limited to :

- Safety helmets, protective eyewear, and clothing.
- Safety harnesses for all elevated workers.
- Proper ladder, cage, and safety operation.

Check all components and parts before installation. All parts are marked with a part number, please refer to the parts list to ensure you have all parts.

Choose a day with low or no wind to install, it is hard to assemble with heavy wind. Do not make any alterations to the structure. Do not hang any weight on the frame during installation, including parts. We are not responsible for any damages or injuries caused by inappropriate installation, unauthorized modifications or extreme weather.



This building is not intended for human occupancy.



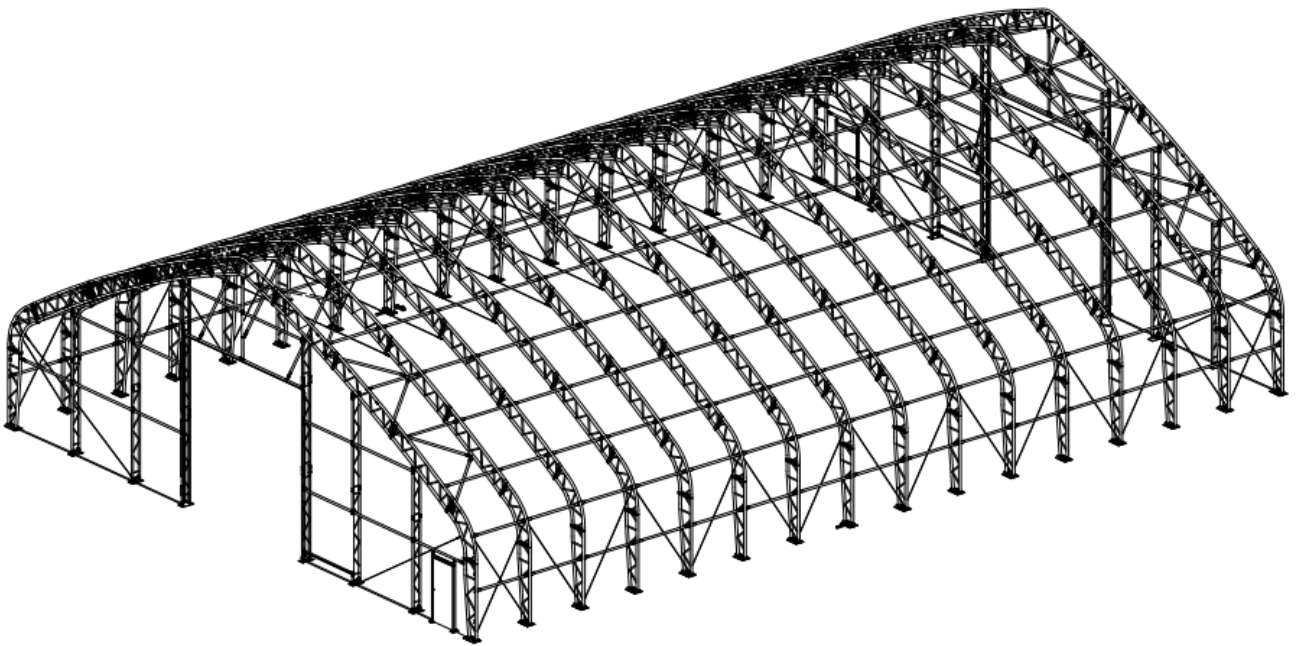



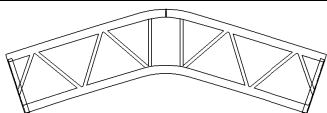
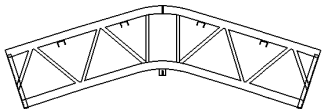
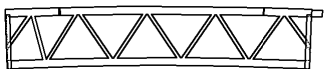

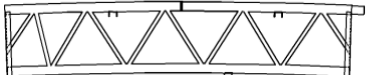
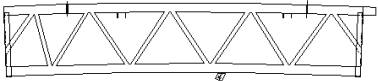
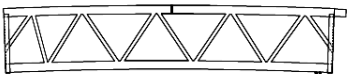
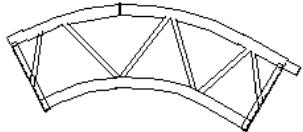
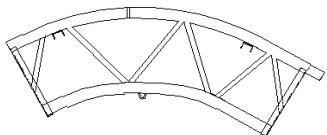
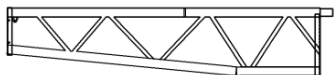
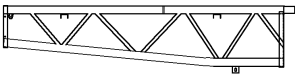
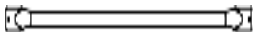
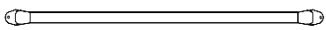
It is recommended to use heavy duty duct tapes to tape the tube connection joint spots to protect the cover from damage and worn. It will help to extend the cover life span.

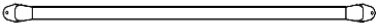

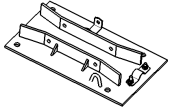
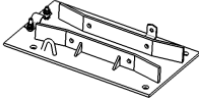
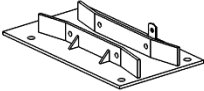
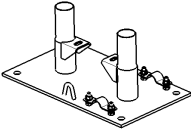
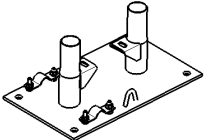
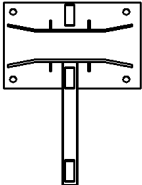

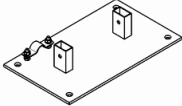
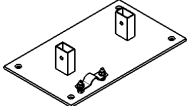



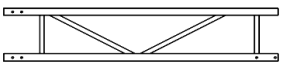
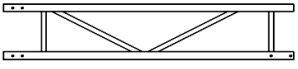
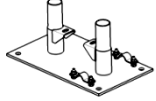
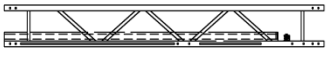
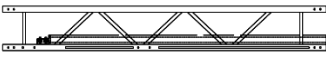

FRAME STRUCTURE DIAGRAM.

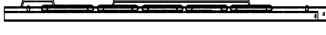

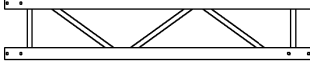
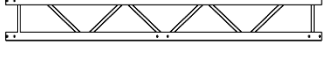
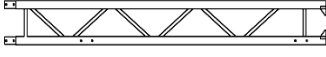
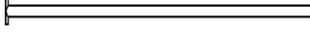

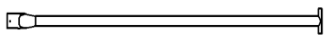

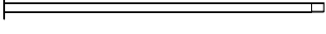



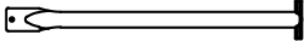

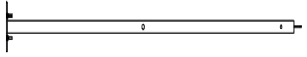
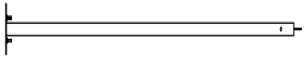

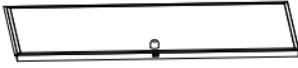









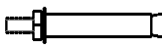



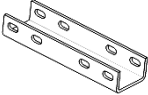
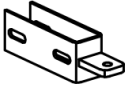

TMG-DT70100-PRO PART LIST



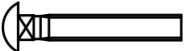
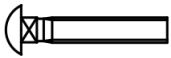

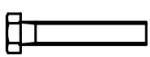
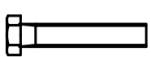

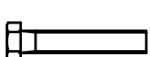
PARTS CODE	GRAPHICAL	DESCRIPTION	LENGTH	QTY	BOX
1		Peak arch tube (for middle trusses)	L3193mm	14	A
1A		Peak arch tube (for front and rear trusses)	L3193mm	2	A
2		Upper and down rafter tube (for middle trusses)	L3104mm	56	Cx20 Dx20 Ex16
2A		Upper rafter tube (for front and rear trusses)	L3104mm	4	F
2B		Middle rafter tube (for front and rear trusses)	L3104mm	4	F
2C		Down rafter tube (for front and rear trusses)	L3104mm	4	E
2D		Middle rafter tube (for middle trusses)	L3104mm	28	Bx20 Fx8
3		Shoulder tube (for middle trusses)	L2094mm	28	Ix13 Jx15
3A		Shoulder tube (front and rear trusses)	L2094mm	4	Ix4
4		Sidewall tube (middle trusses)	L2514mm	28	Gx28
4A		Sidewall tube (for front and rear trusses)	L2514mm	4	Hx4
5		Roof purlin (horizontal tube)	L2040mm	225	H
5A		Diagonal bracing tube	L2540mm	24	C

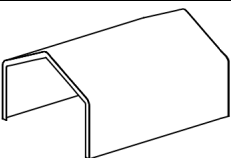
5B		Support tube	L2820mm	2	B
5C		Support tube	L2820mm	4	B
5L		Baseplate for front and rear truss left corners	W280xL480mm	2	A
5R		Baseplate for front and rear truss right corners	W280xL480mm	2	A
6		Baseplates	W280xL430mm	26	A
6L		Left column baseplate	W200xL410mm	2	A
6R		Right column baseplate	W200xL410mm	2	A
6A		Baseplates	W280xL430mm	2	A
7		Ratchets	3T	132	A
7B		Clip		6	A
7L		Left baseplate of door frame	W200xL410mm	2	A
7R		Right baseplate of door frame	W200xL410mm	2	A
8		Top cover tension tube (for both bottom sides)	L1993mm	30	D
8A		Top cover tension tube (for both bottom sides)	L650mm	2	D
8B		Top cover tension tube (for both bottom sides)	L570mm	2	D

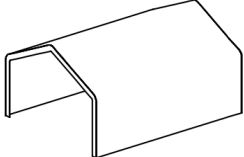
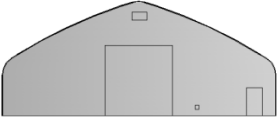
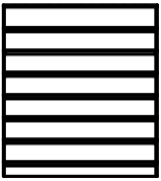
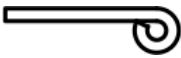
8L		Front and rear vertical door rail (left side upper part)	L1300mm	2	D
8R		Front and rear vertical door rail (right side upper part)	L1300mm	2	D
9		Column baseplate	W200xL410mm	4	A
9L		Front and rear vertical door rail (left side middle part)	L2800mm	2	D
9R		Front and rear vertical door rail (right side middle part)	L2800mm	2	D
10L		Front and rear vertical door rail (left side lower part)	L2795mm	2	D
10R		Front and rear vertical door rail (right side lower part)	L2795mm	2	D
11		Lower vertical tubes	L2880mm	6	E
11A		Upper vertical tubes	L1563mm	4	H
11B		Upper vertical tubes	L3008mm	4	B
11C		Lower vertical tubes	L2880mm	2	B
12		Door cross tubes (left and right)	L2723mm	4	B
12A		Door cross tubes (left and right)	L2244mm	8	H
12B		Door cross tubes (left)	L2325mm	2	H
12C		Door cross tubes (right)	L2325mm	2	B
13		Door cross beam (left)	L2684mm	2	B
13A		Door cross beam (right)	L2854mm	2	B

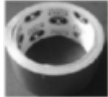
13B		Door center vertical supporting rod for cross beam	L2564mm	2	B
13C		Upper cross tubes (left and right)	L2702mm	8	B
14		Door hand winch crossing tube	L2244mm	2	B
14A		Side door left tube	L2200mm	2	H
14B		Side door right tube	L2200mm	2	H
14C		Side door upper tube	L920mm	2	H
14D		Side door	W925xL2005mm	2	J
15		Bottom tension bar (front and rear truss)	L2460mm	2	E
15A		Bottom tension bar (front and rear truss)	L2650mm	4	E
15B		Bottom tension bar (front and rear truss)	L2200mm	4	E
15C		Bottom tension bar (front and rear truss)	L820mm	2	E
15D		Bottom tension bar (front and rear truss)	L590mm	2	E
16		Roll up door dropping tubes (to connect #16A)	L2810mm	16	D
16A		Roll up door dropping tubes (to connect #16)	L2775mm	16	D
17		Front and rear truss left and right steel cables	L5700mm	4	A
18		Sidewall frame steel tension cables	L4000mm	34	A
19		Middle truss crossing steel tension cables	L8460mm	14	A
20		Expansion bolts	φ16x150mm	184	A
21		Tie down straps (for #7)	W38xL1000mm	130	A
22		Cable connection plate	L91mm	20	A

23		Roll up door hand winch	3T	2	A
23A		Wire rope for front and rear door hand winch	L25m	2	A
24		Front and rear vertical door rail connection plate	L240mm	16	A
24A		Front and rear vertical door rail end plate (floatable to keep door rail straight)	L215mm	12	A
24B		Tube clamps	φ76mm	28	A
24D		Tube clamps	φ58mm	12	A
25		Tension tube end water plug	φ32mm	36	A
26		Self locking bolt and nuts	M10x100	240	A
27		Self locking bolt and nuts	M8x80	36	A
28		Strengthened bolt and nuts	M14x30	768	A
29		Hex bolt and nuts	M10x100	154	A
29A		Hex bolt and nuts	M10x70	12	A
30		Hex bolt and nuts	M10x30	22	A
30A		Hex bolt and nuts	M12x30	16	A
30B		Hex bolt and nuts	M10x50	40	A
31		Braided rope	L180m	2	A
32		Top cover A	W14.3xL31.2m	1	F

33		Top cover B	W17xL31.2m	1	F
34		Front and rear truss cover panel	W8.9xL21.3m	2	H
34A		Front and rear roll up door cover panel	W5.4xL5.5m	2	H
35		Front and rear fabric tarp secure pin	L150mm	4	A
36		Plastic hose	φ25mmxL4m	32	C
36A		Connector (for connection #36)	φ25mm	28	A
37		Scratch resistant tape	L10m	8	A
38		Pressing plate	L2000mm	12	D
38A		Pressing plate	L1000mm	6	D
39		Tapping screw	#12x25mm	136	A

STEP 1 : BASEPLATE POSITIONING AND INSTALLATION.

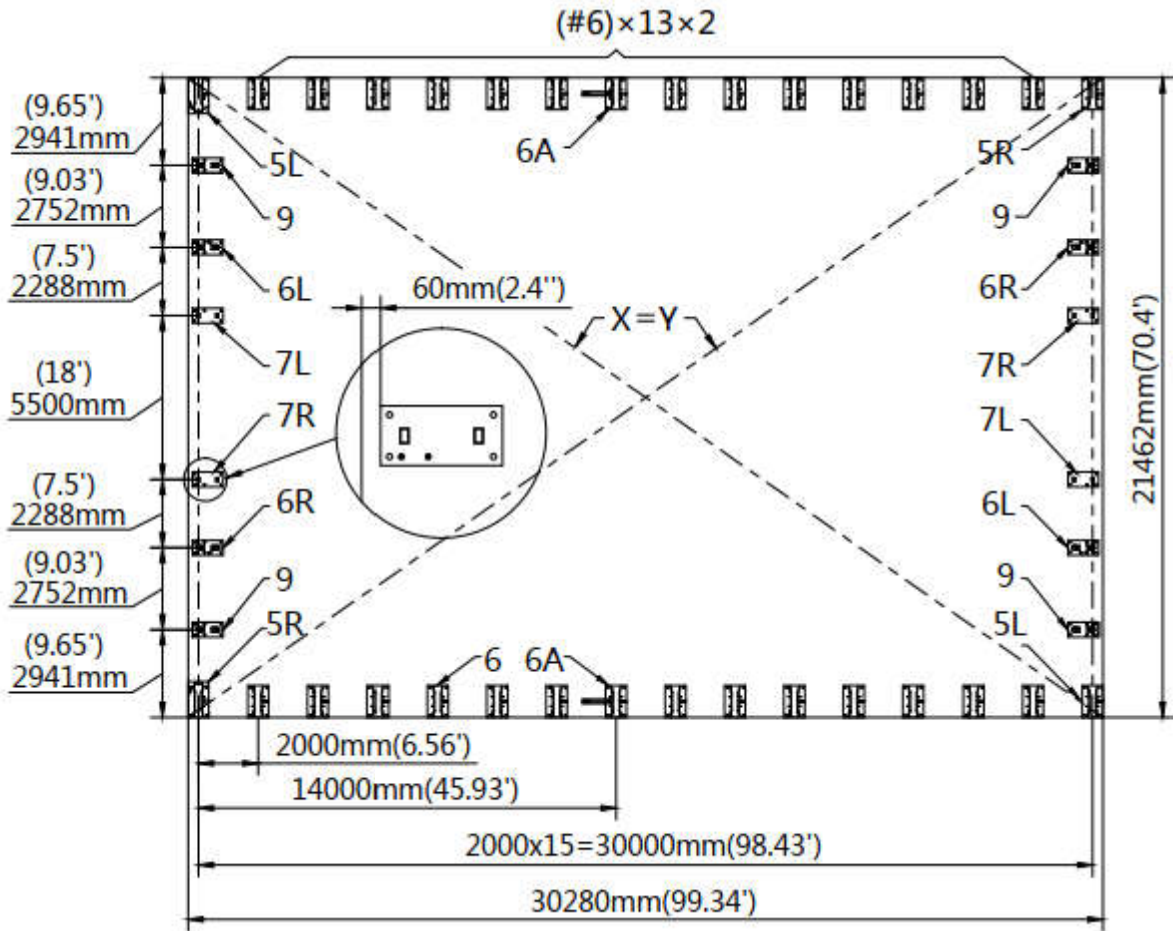

- Installation diagram of expansion bolt.

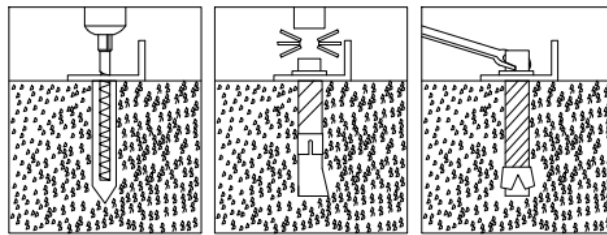



NO.	PART	QTY
5L		2
5R		2
6		26
6A		2
6L		2

NO.	PART	QTY
6R		2
7L		2
7R		2
9		4
20		176

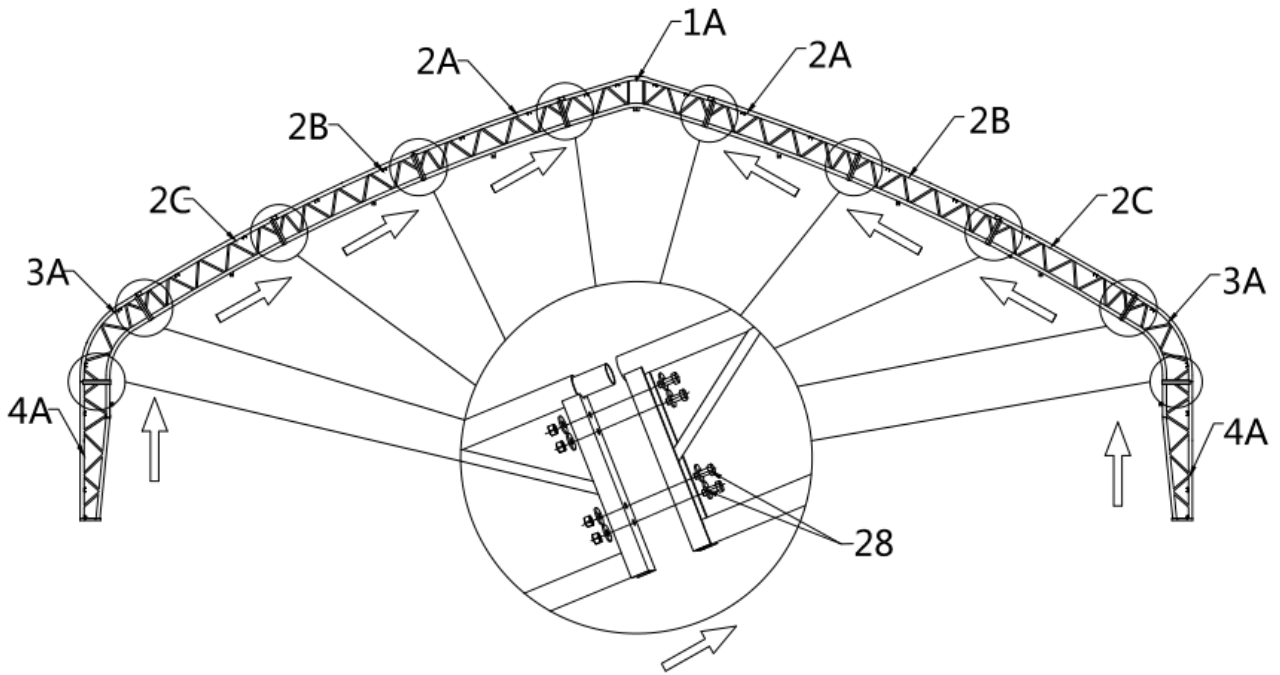
STEP 2 : INSTALLATION OF FRONT AND REAR 2 GROUP TRUSSES.

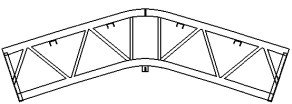
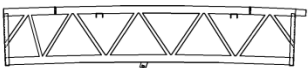

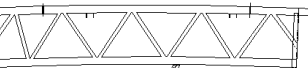
NO.	PART	QTY
1A		1x2
2A		2x2
2B		2x2
2C		2x2

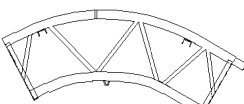
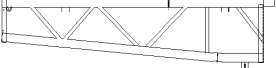
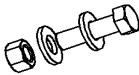
NO.	PART	QTY
3A		2x2
4A		2x2
28		40x2

STEP 3 : INSTALLATION OF MIDDLE 14 GROUP TRUSS.

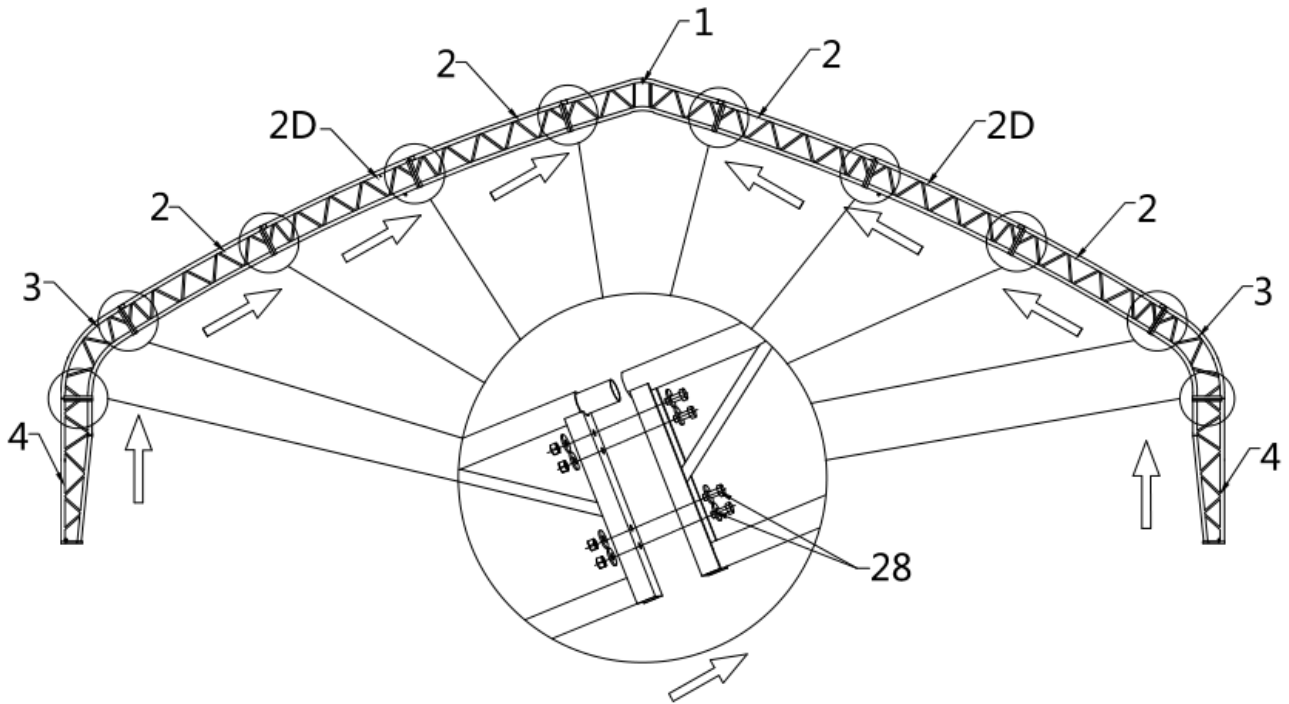

NO.	PART	QTY
1		1x14
2		4x14
2D		2x14

NO.	PART	QTY
3		2x14
4		2x14
28		40x14

STEP 4 : WRAP (#37) AROUND THE SHARP POINTS OF THE JOINT TO AVOID FRICTION BETWEEN THE FABRIC AND THE INTERFACE.

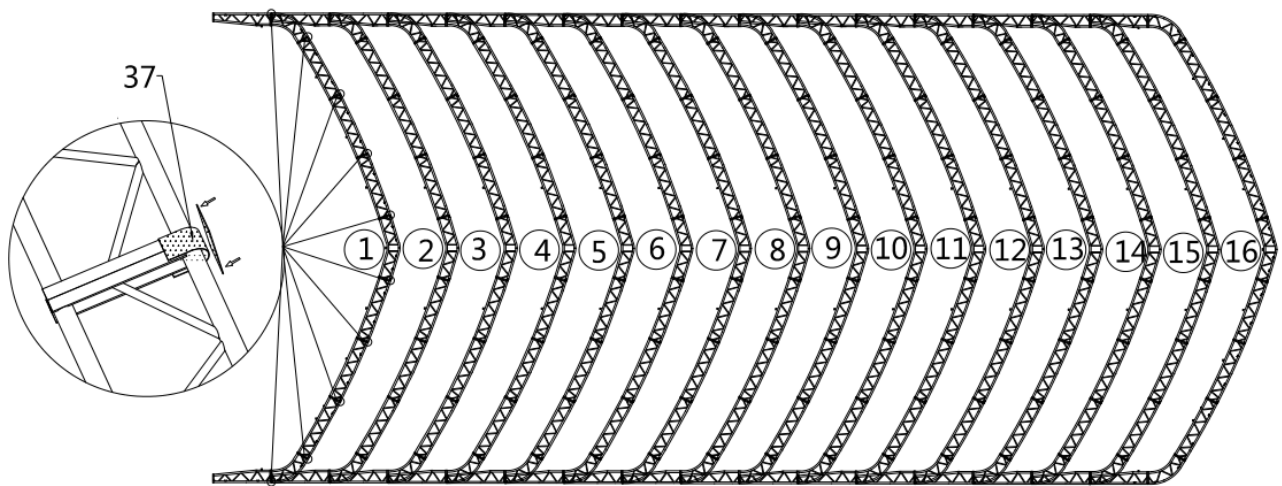

NO.	PART	QTY
37		8

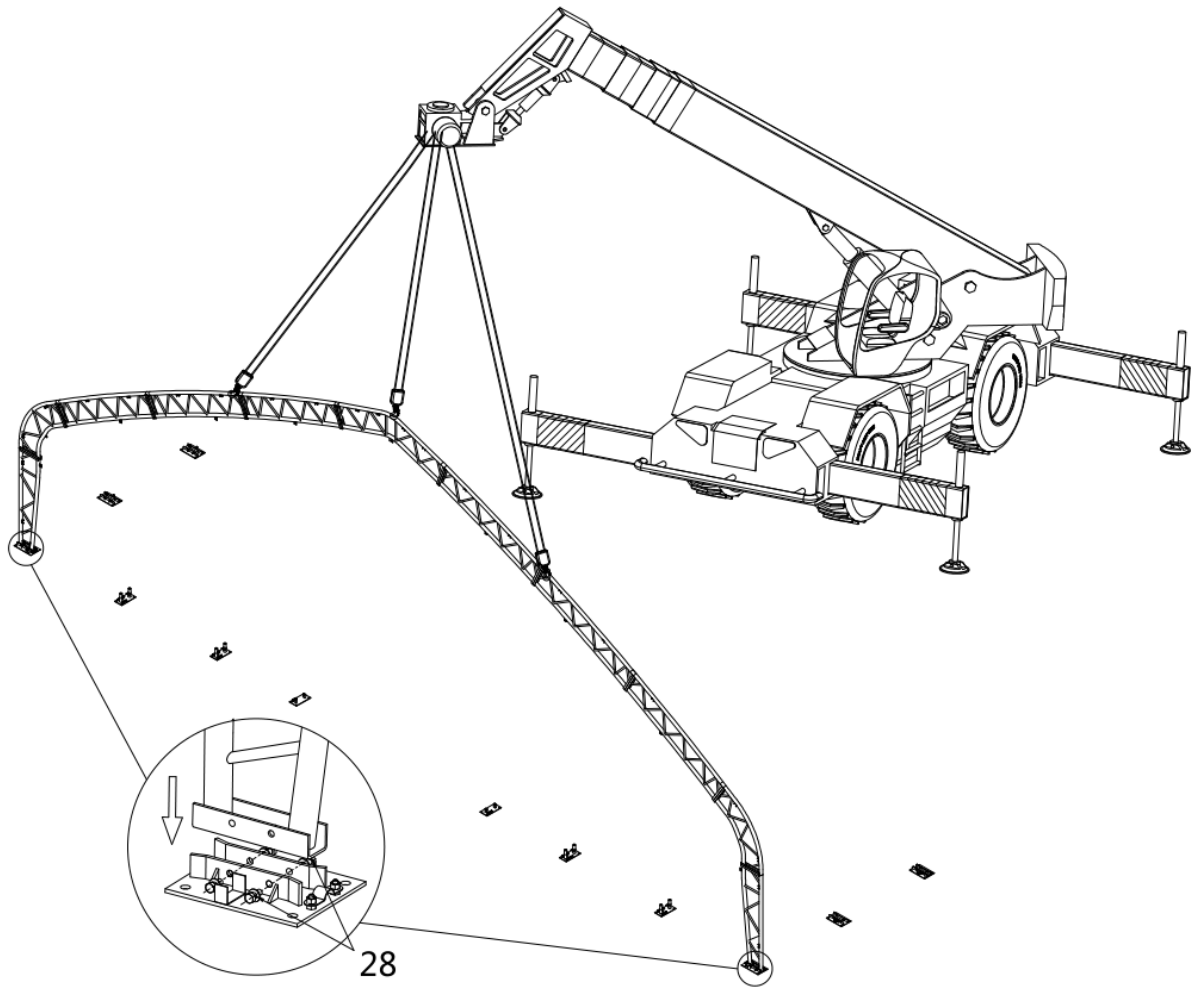

STEP 5 : PUT UP THE FRONT TRUSS (IT IS SUGGESTED TO USE CRANE FOR HOISTING).

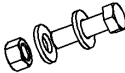

NO.	PART	QTY
28		8

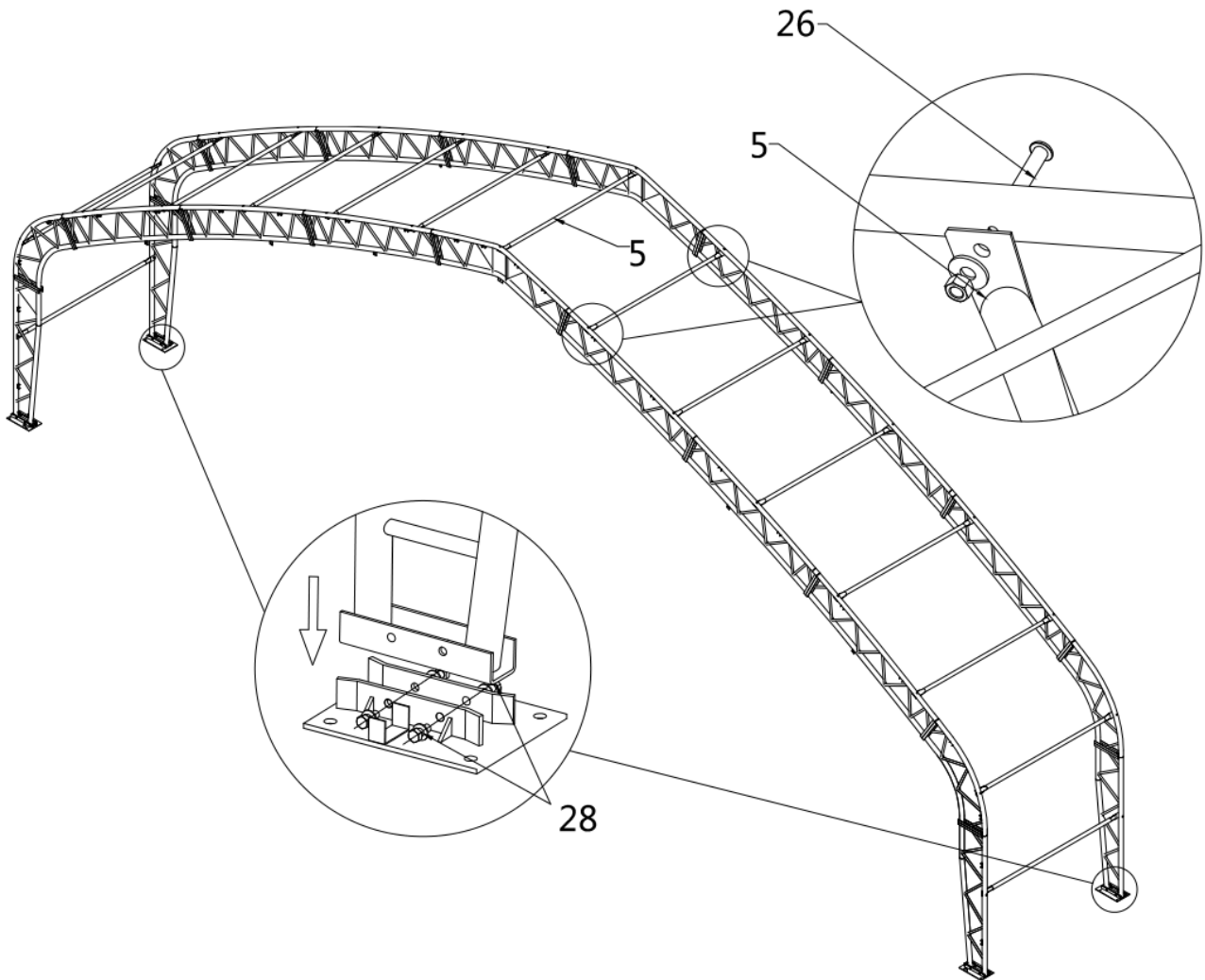
STEP 6 : PUT UP THE 2ND TRUSS, AND CONNECT ALL PURLINS (#5) BETWEEN 1ST AND 2ND.

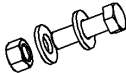

NO.	PART	QTY
5		15
26		30
28		8

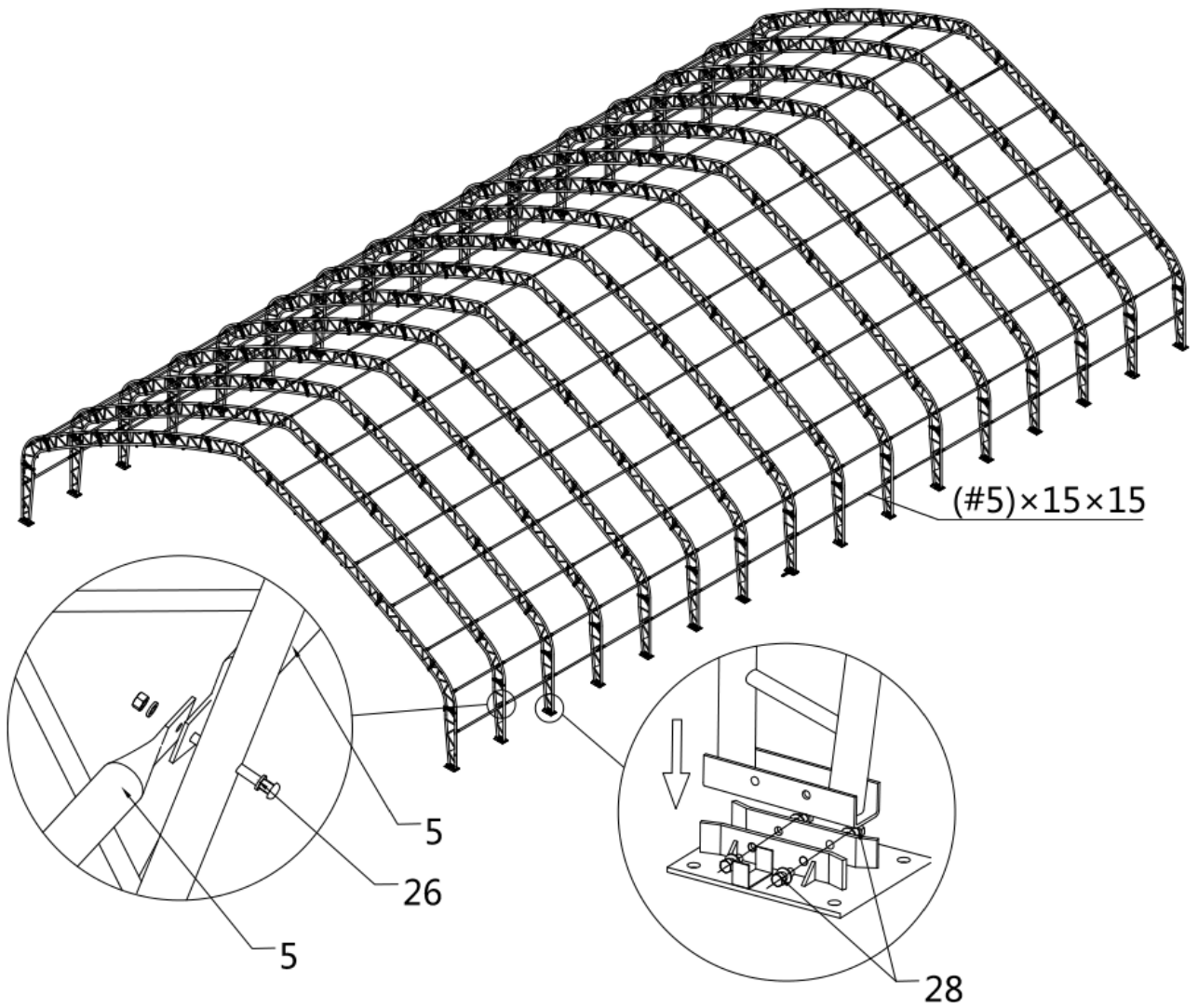

STEP 7 : REPEAT ABOVE STEP TO PUT UP ALL OTHER TRUSSES, AND CONNECT ALL PURLINS.

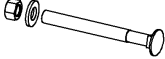
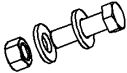

NO.	PART	QTY
5		210
26		210
28		112

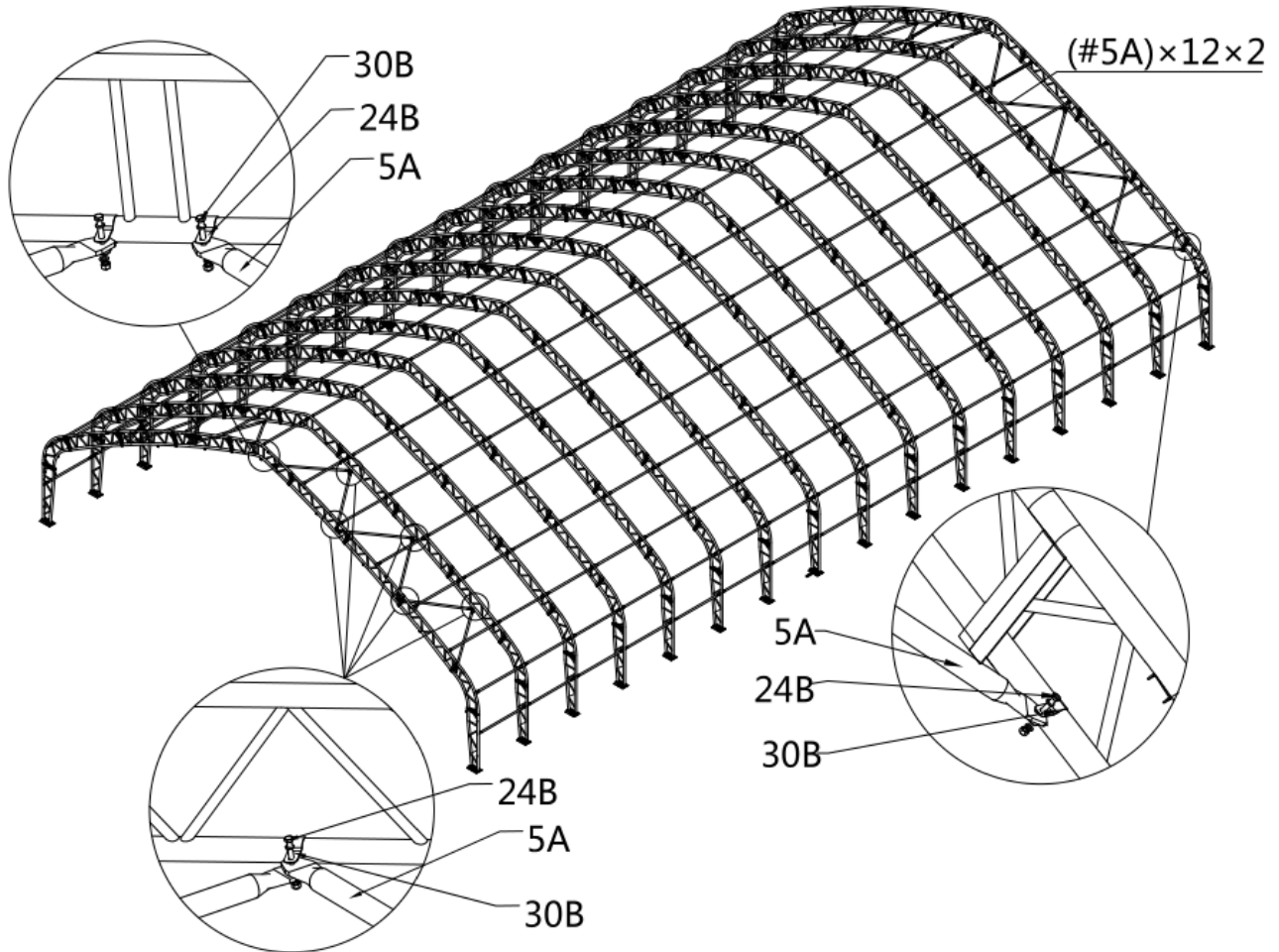

STEP 8 : INSTALLATION OF DIAGONAL PURLINS (THE FRONT AND REAR MOUNTING METHODS ARE THE SAME).

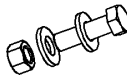

NO.	PART	QTY
5A		24
24B		28
30B		28

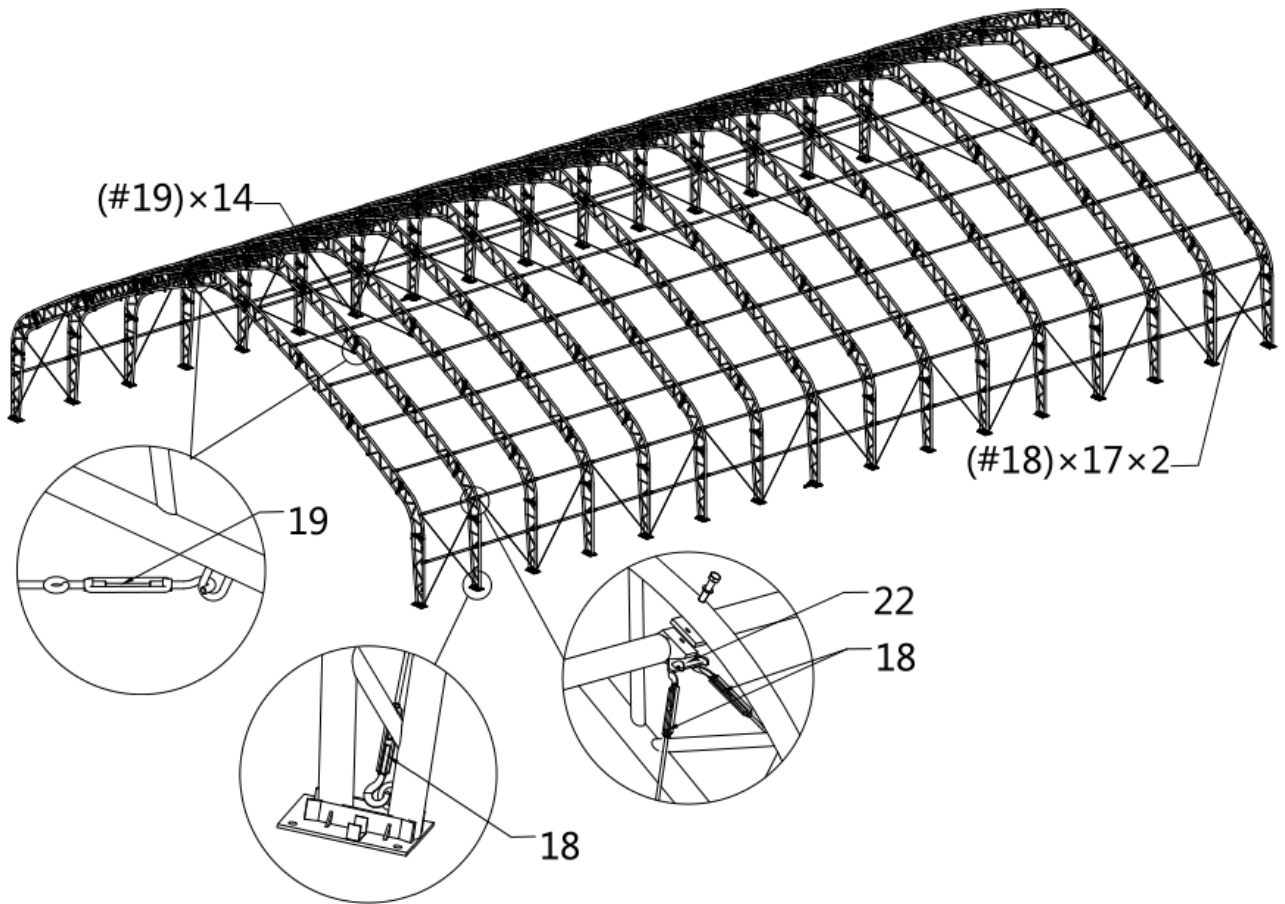
STEP 9 : TENSION CABLE INSTALLATION, ALL CABLES ARE DIAGONALLY INSTALLED ON EACH.



NO.	PART	QTY
18		34
19		14
22		20

STEP 10 : DOOR COLUMN INSTALLATION (THE FRONT AND REAR MOUNTING METHODS ARE THE SAME).

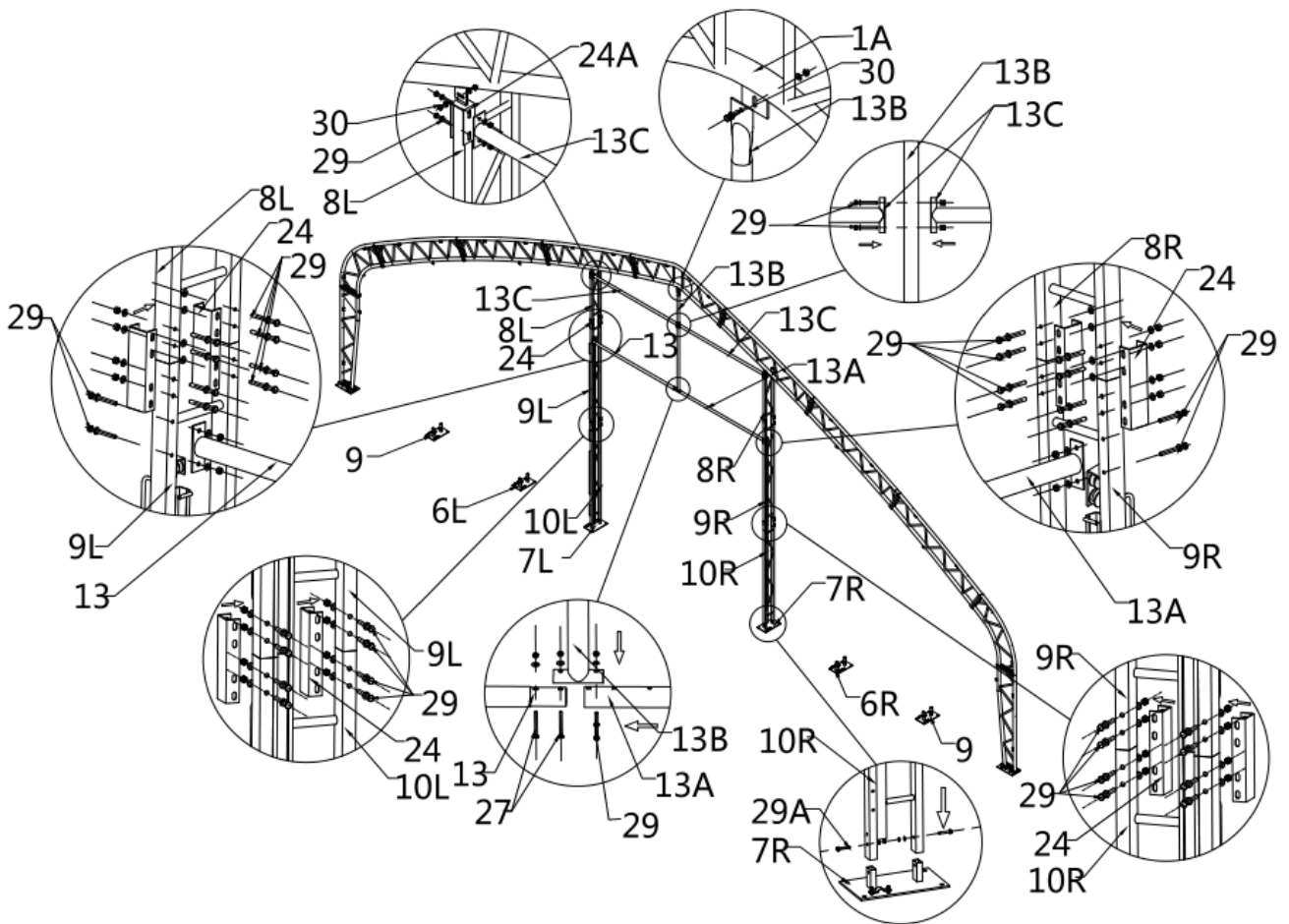

NO.	PART	QTY
8L		2
8R		2
9L		2
9R		2
10L		2
10R		2
13		2
13A		2

NO.	PART	QTY
13B		2
13C		4
24		16
24A		4
27		4
29		86
29A		8
30		6

STEP 11-1 : DOOR SUPPORT PIPE INSTALLATION (THE FRONT AND REAR MOUNTING METHODS ARE THE SAME).

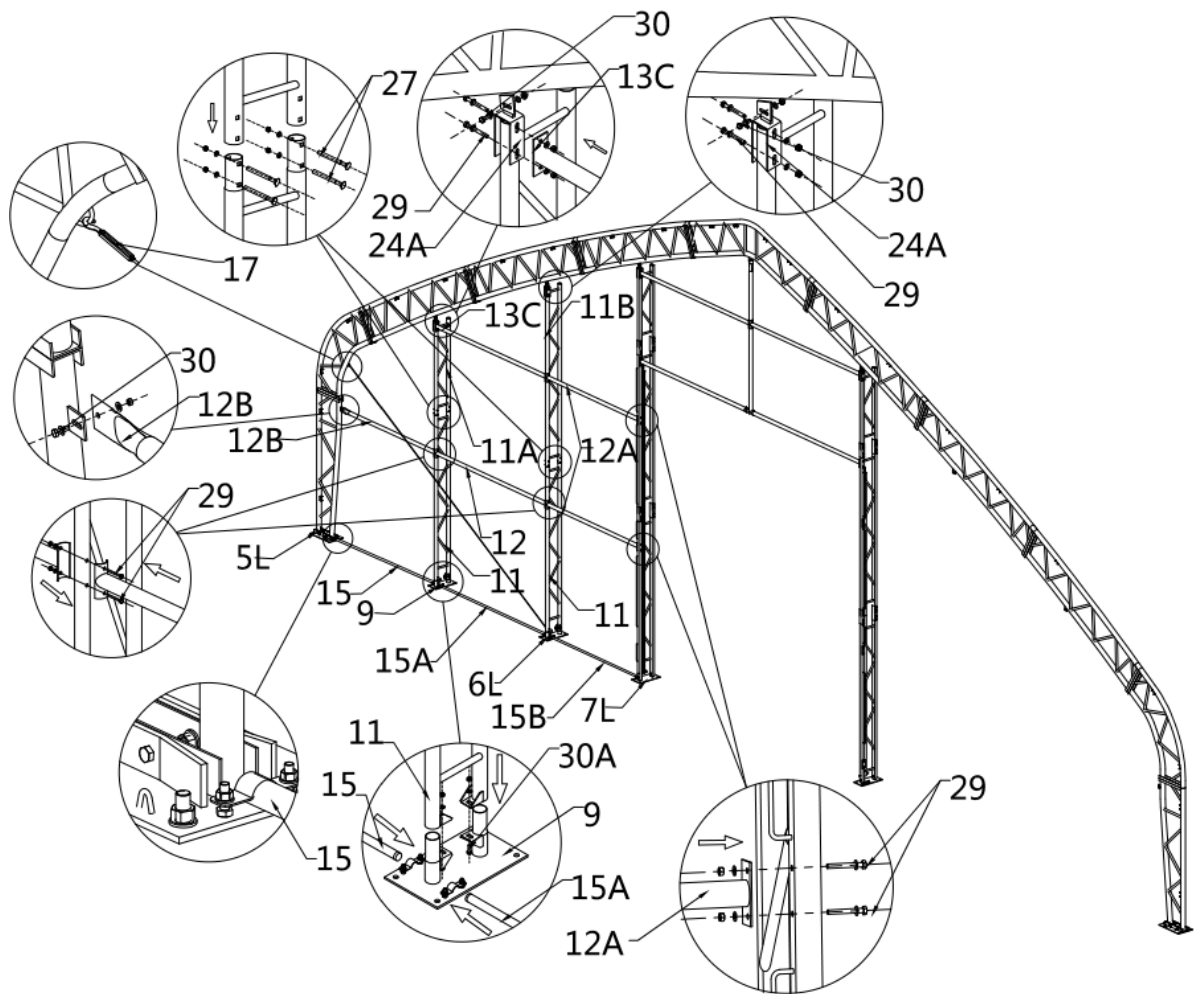

NO.	PART	QTY
11		4
11A		2
11B		2
12		2
12A		4
12B		2
13C		2
15		2

NO.	PART	QTY
15A		2
15B		2
17		2
24A		4
27		16
29		28
30		6
30A		8

STEP 11-2 : DOOR SUPPORT PIPE INSTALLATION (THE FRONT AND REAR MOUNTING METHODS ARE THE SAME).

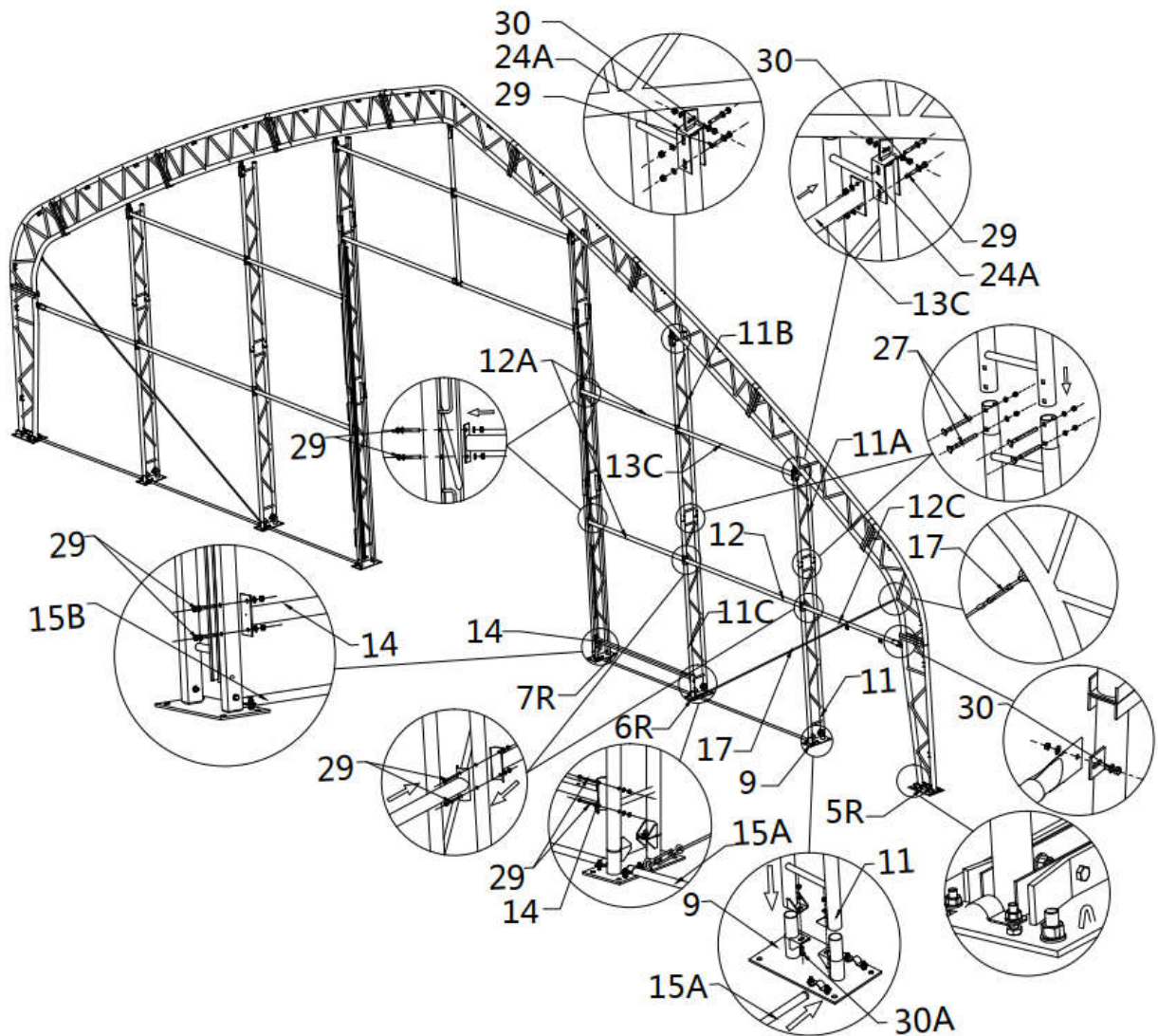

NO.	PART	QTY
11		2
11A		2
11B		2
11C		2
12		2
12A		4

NO.	PART	QTY
12C		2
13C		2
14		2
15A		2
15B		2
17		2

NO.	PART	QTY
24A		4
27		16
29		36
30		6
30A		8

STEP 11-3 : SIDE DOOR INSTALLATION (THE FRONT AND REAR MOUNTING METHODS ARE THE SAME).

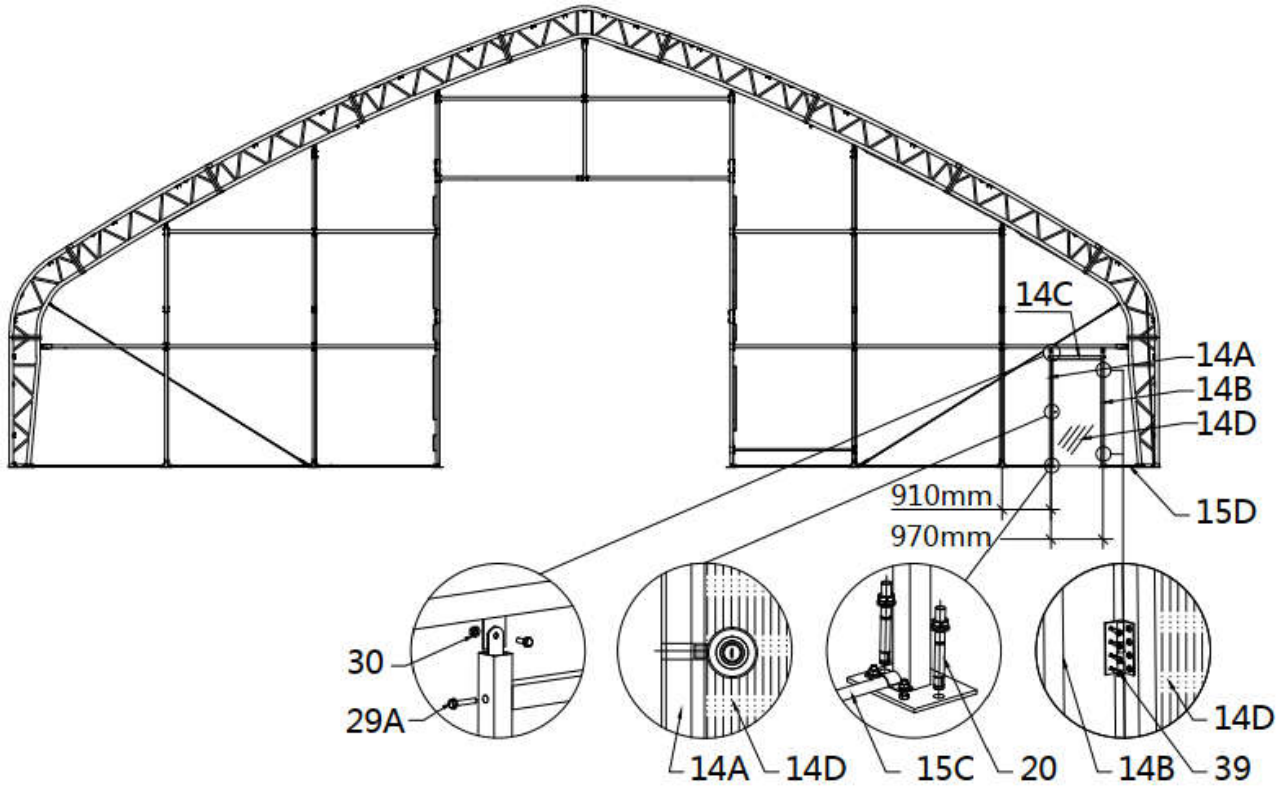

NO.	PART	QTY
14A		2
14B		2
14C		2
14D		2
15C		2

NO.	PART	QTY
15D		2
20		8
29A		4
30		4
39		16

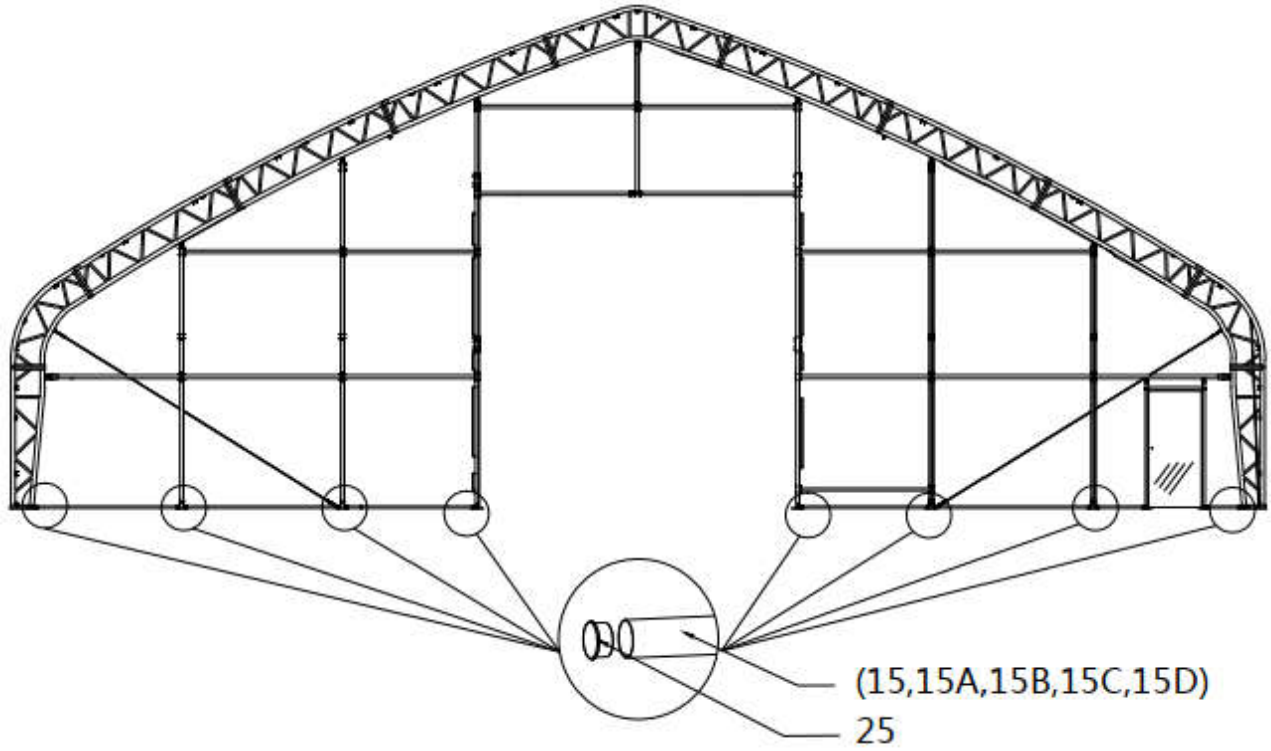

STEP 12 : INSTALL THE WATERPROOF PLUG (THE FRONT AND REAR MOUNTING METHODS ARE THE SAME).

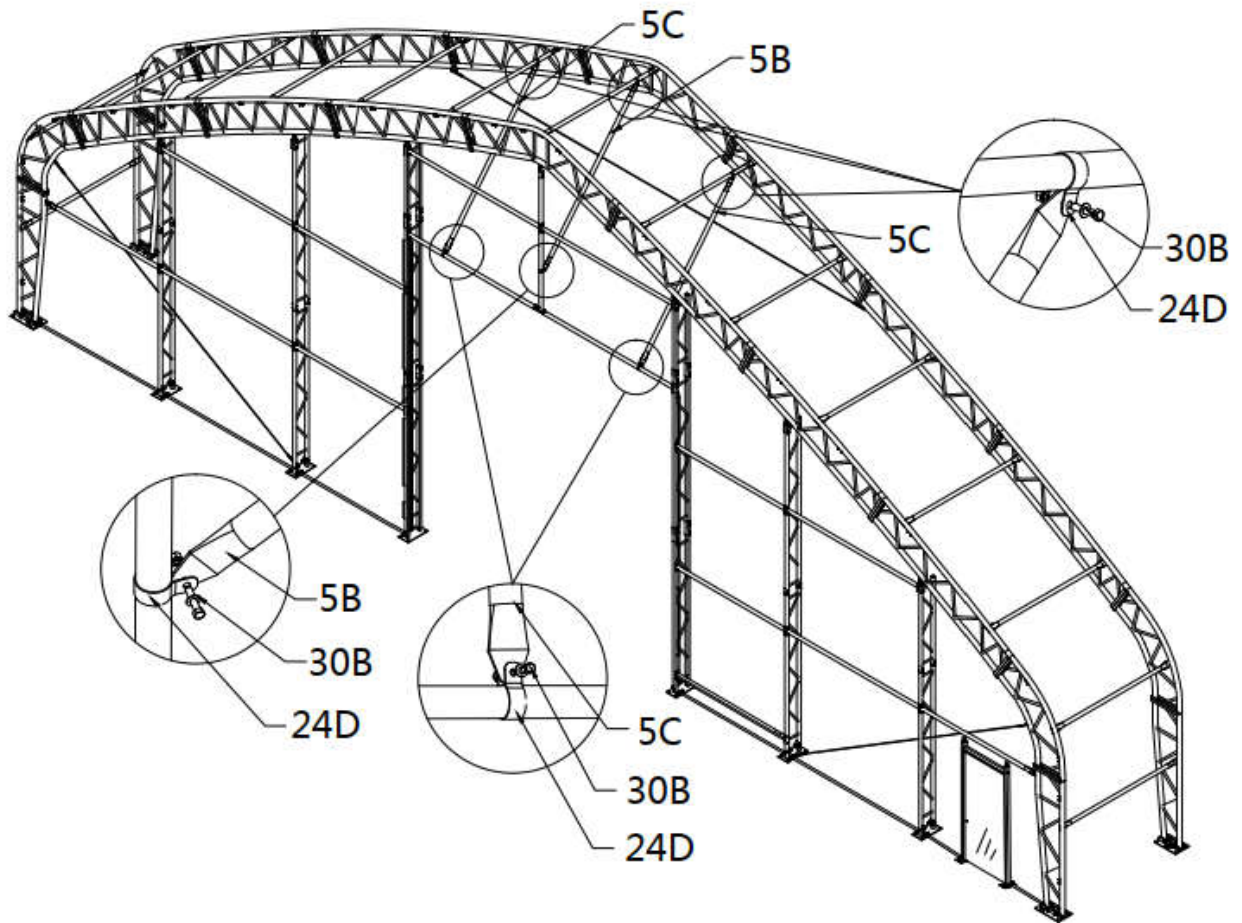

NO.	PART	QTY
25		28

STEP 13 : INSTALL VERTICAL DIAGONAL SUPPORT PIPE (#5B, #5C) (THE FRONT AND REAR MOUNTING METHODS ARE THE SAME).

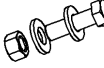

NO.	PART	QTY
5B		2
5C		4
24D		12
30B		12

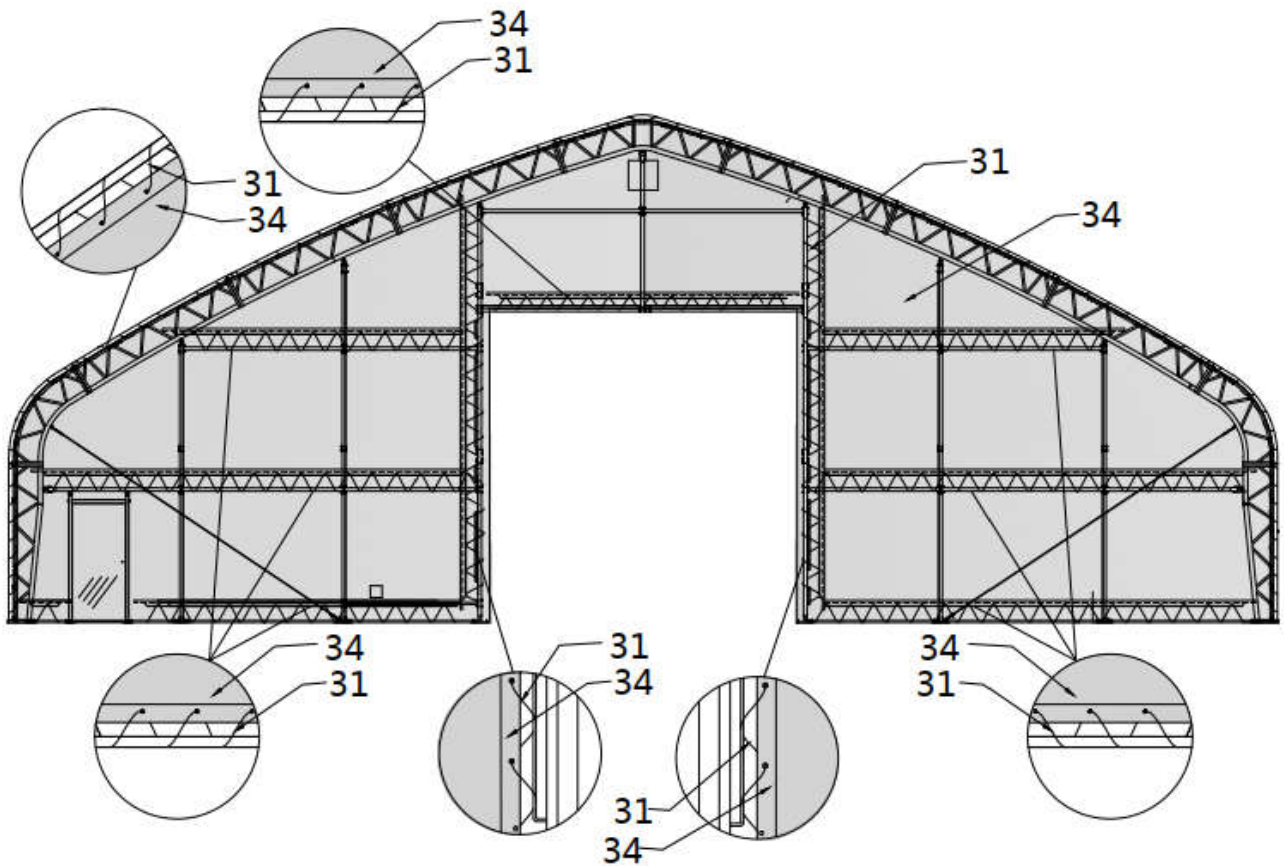

STEP 14 : INSTALL THE DOOR COVERING CLOTH (THE FRONT AND REAR MOUNTING METHODS ARE THE SAME).

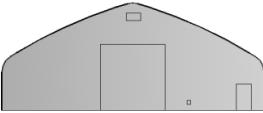

NO.	PART	QTY
31		1
34		2

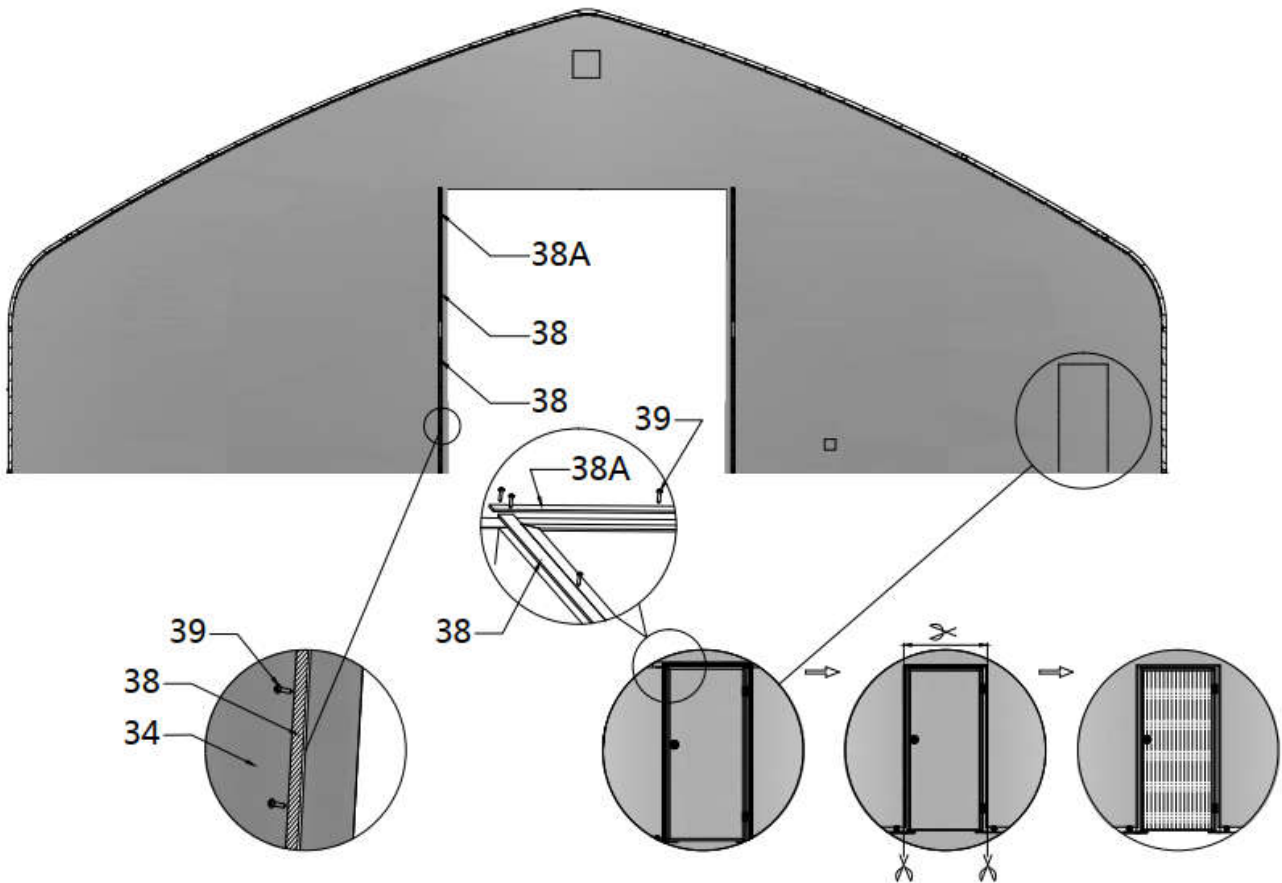
STEP 15 : INSTALL THE FRONT DOOR METAL STRIP (THE FRONT AND REAR MOUNTING METHODS ARE THE SAME).





NO.	PART	QTY
38		12
38A		6
39		120

STEP 16 :

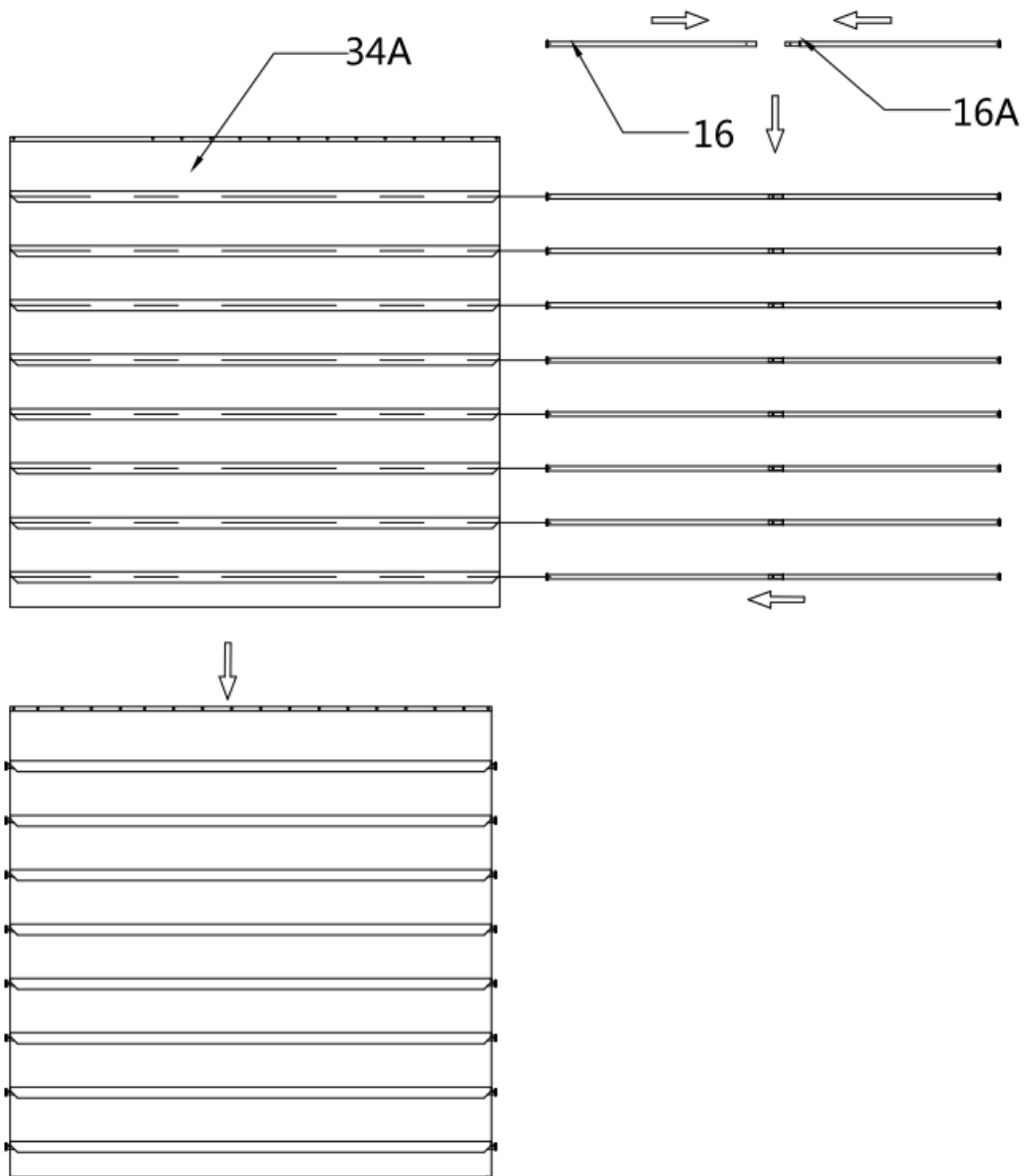
1. DOOR CURTAIN INSTALLATION (THE FRONT AND REAR MOUNTING METHODS ARE THE SAME).



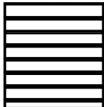

NO.	PART	QTY
16		16
16A		16
34A		2

STEP 16 :

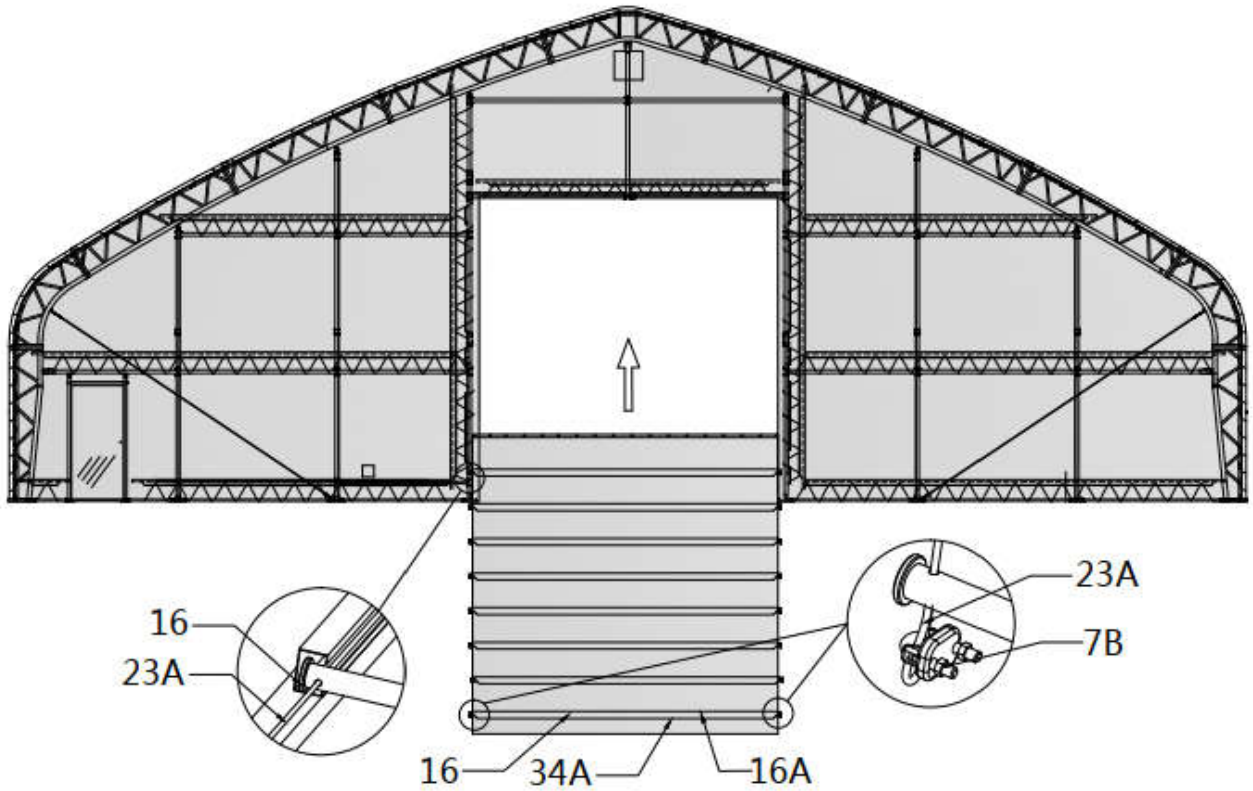
2. DOOR CURTAIN INSTALLATION (THE FRONT AND REAR MOUNTING METHODS ARE THE SAME).





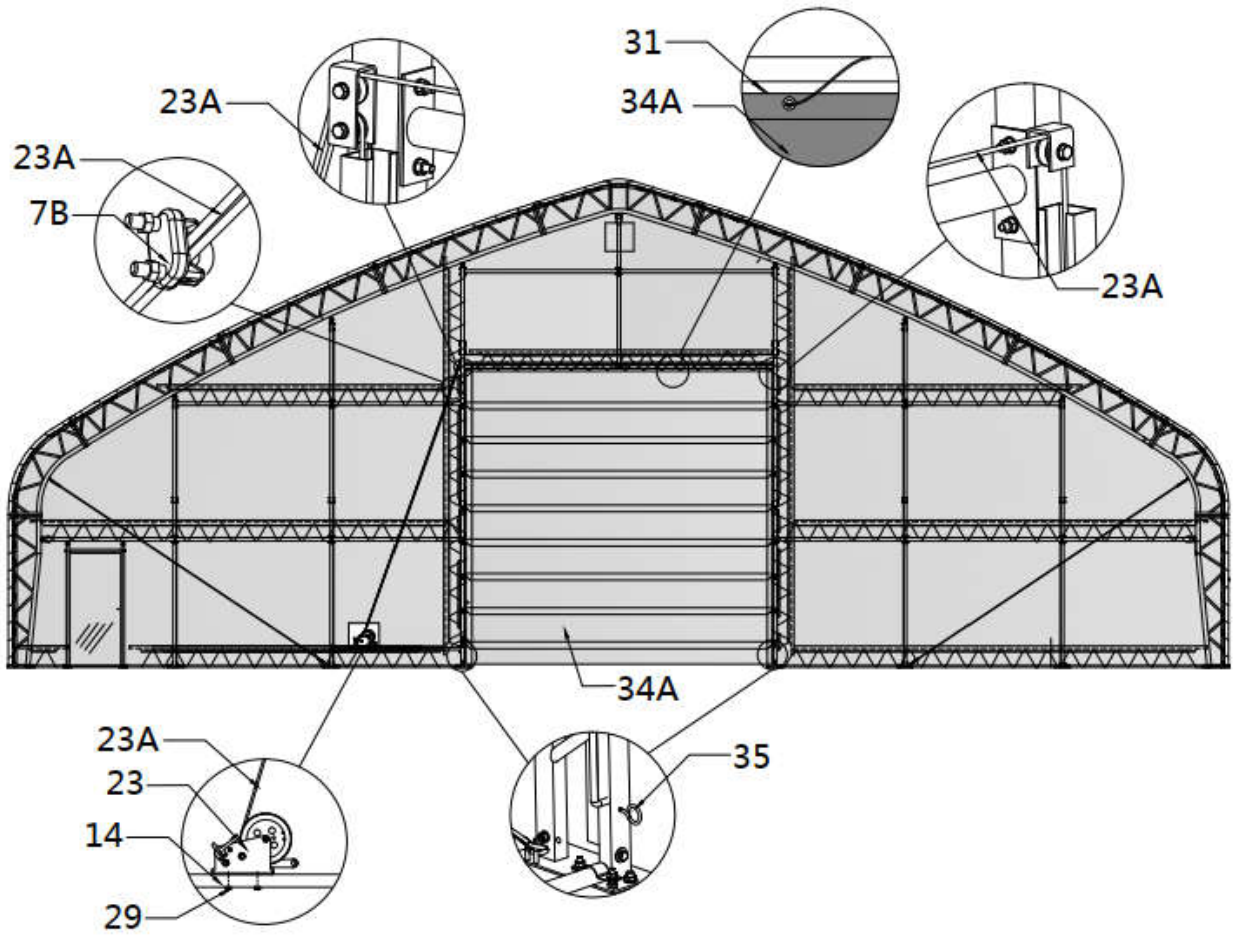

NO.	PART	QTY
7B		4
23A		2

STEP 16 :

3. DOOR CURTAIN INSTALLATION (THE FRONT AND REAR MOUNTING METHODS ARE THE SAME).

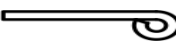

NO.	PART	QTY
7B		2
23		2
29		4
31		1
35		4

STEP 17 :

- 1. INSTALL THE TOP COVER A (#32).**

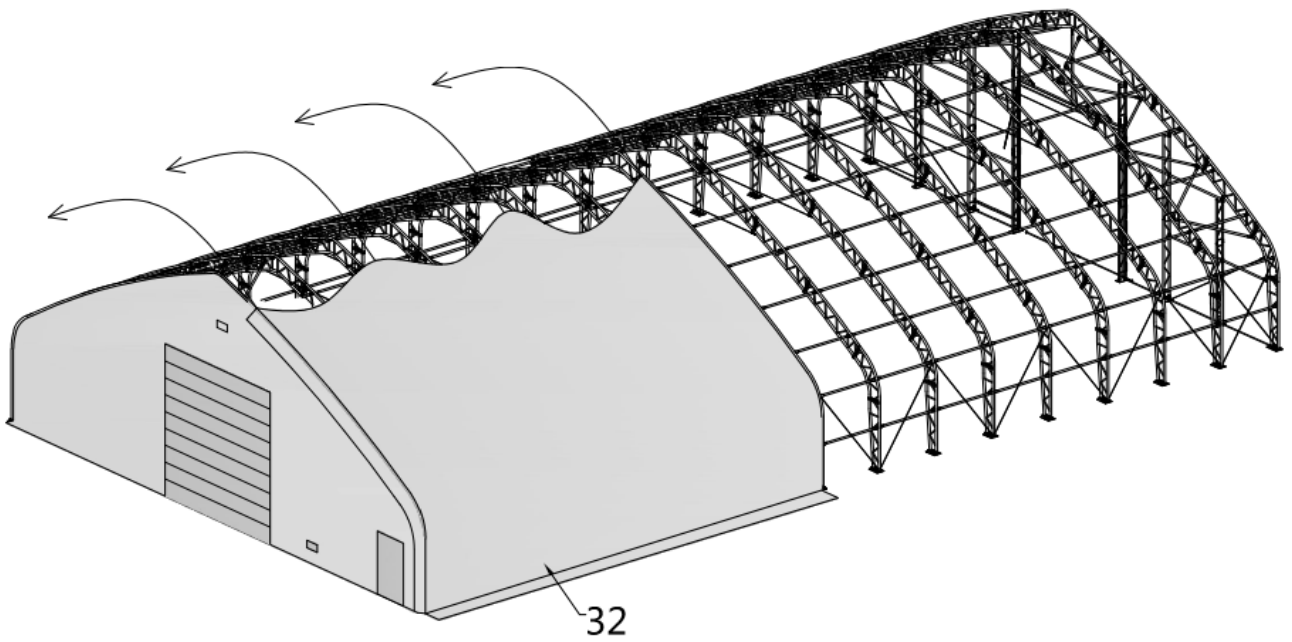

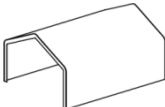

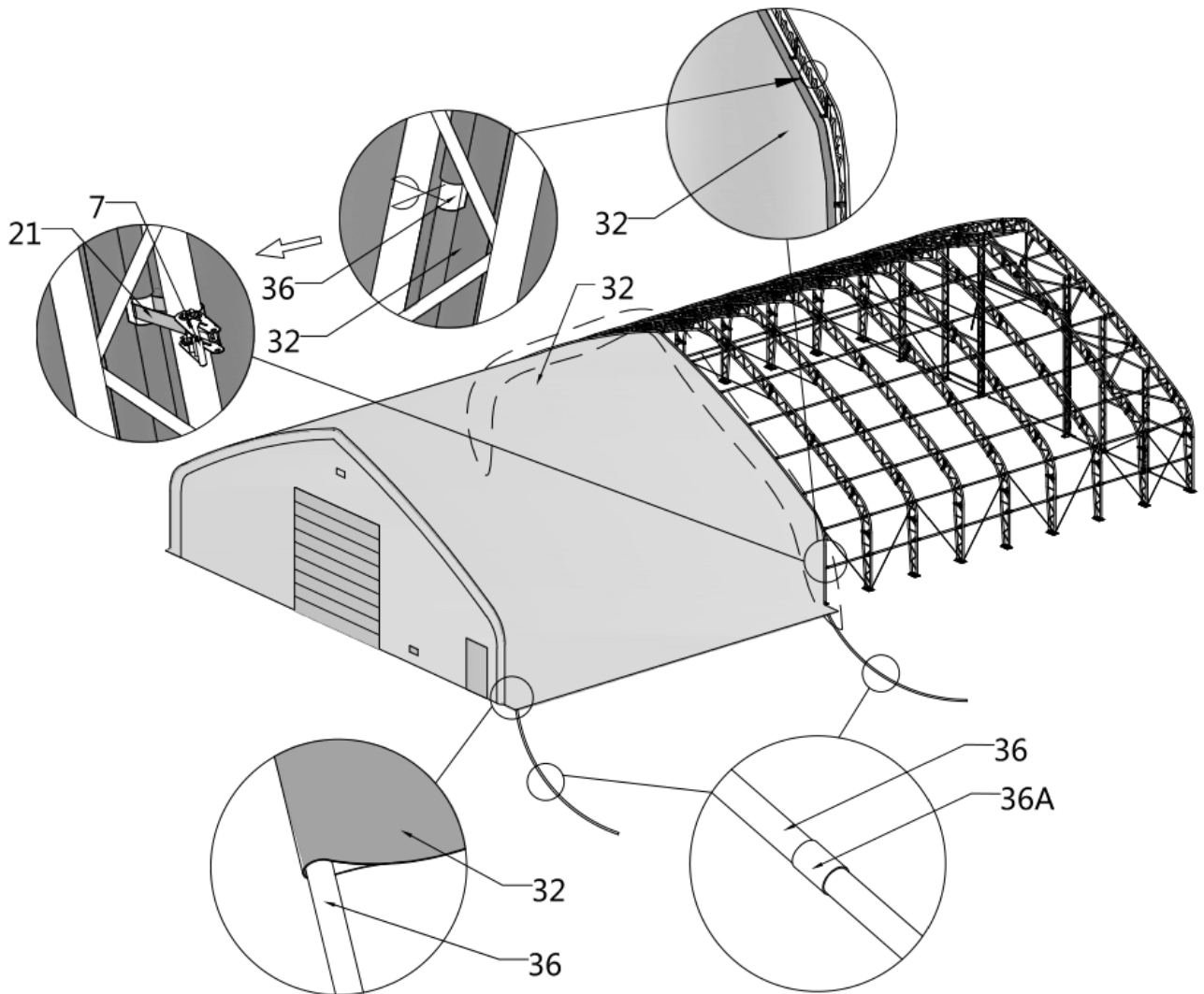

NO.	PART	QTY
32		1

STEP 17 :

2. INSTALL THE TOP COVER A (#32).





NO.	PART	QTY
7		24
21		24
36		16
36A		14

STEP 17 :

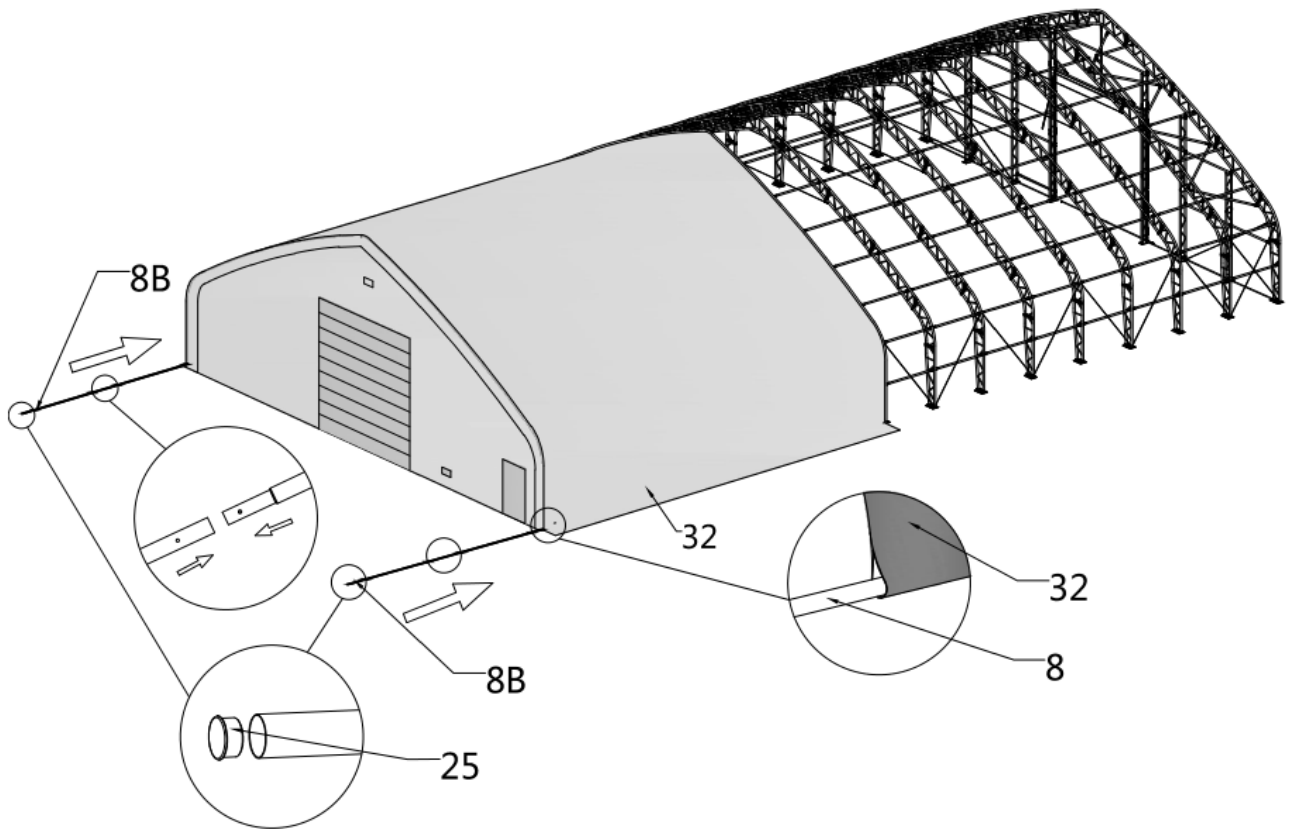
3. INSTALL THE TOP COVER A (#32).

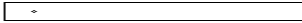



NO.	PART	QTY
8		14
8B		2
25		4

STEP 17 :

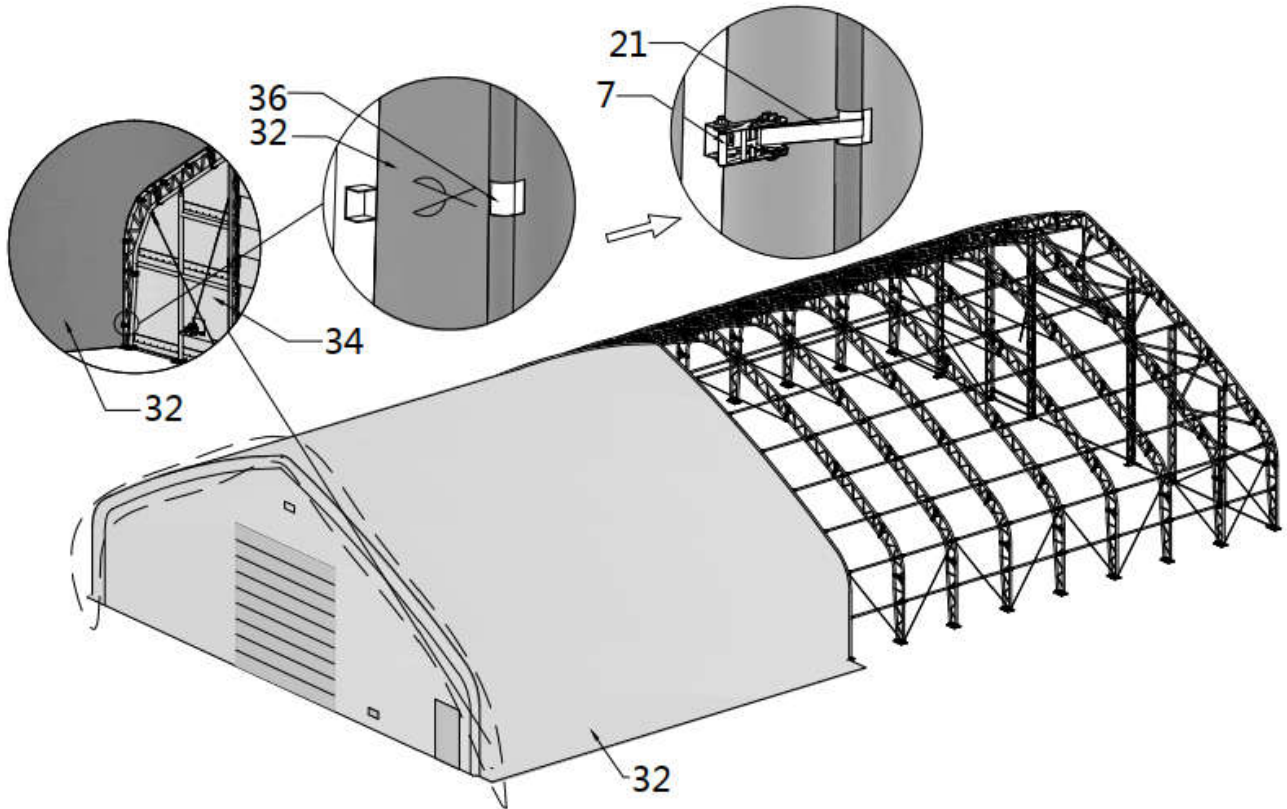
4. INSTALL THE TOP COVER A (#32).



NO.	PART	QTY
7		24
21		24

STEP 18 :

- 1. INSTALL THE TOP COVER B (#33).**

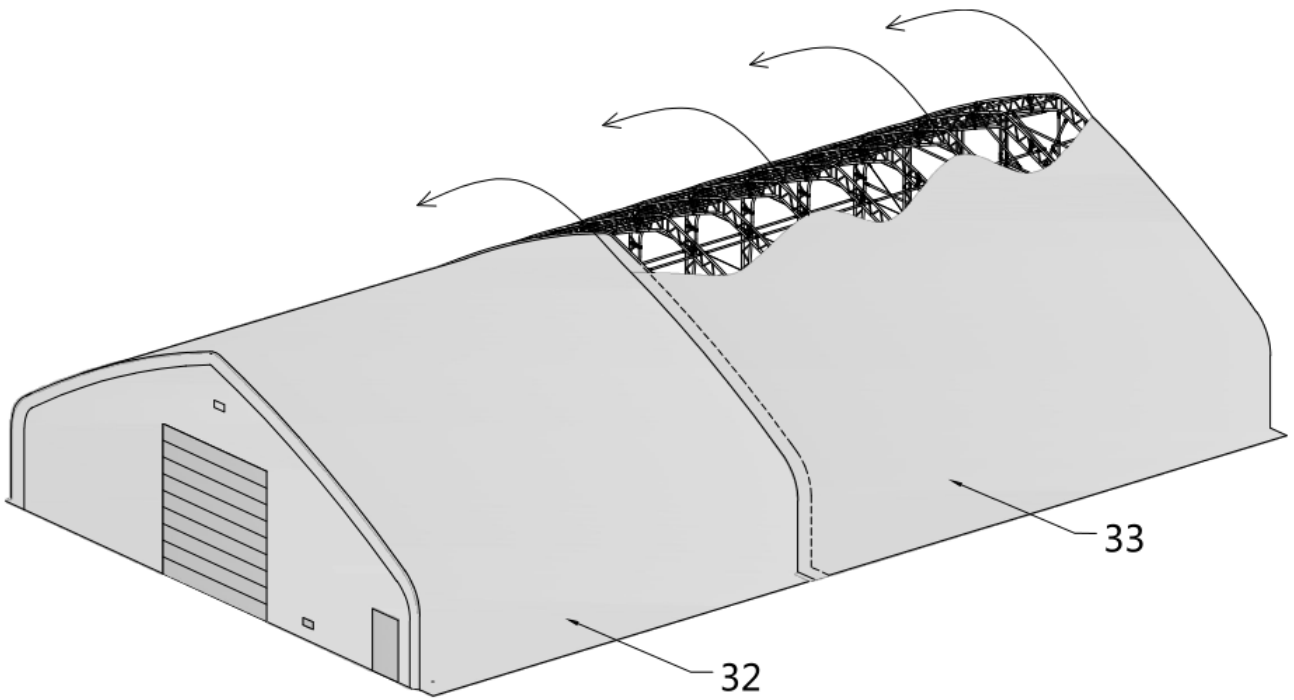

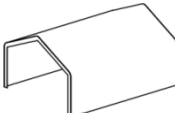

NO.	PART	QTY
33		1

STEP 18 :

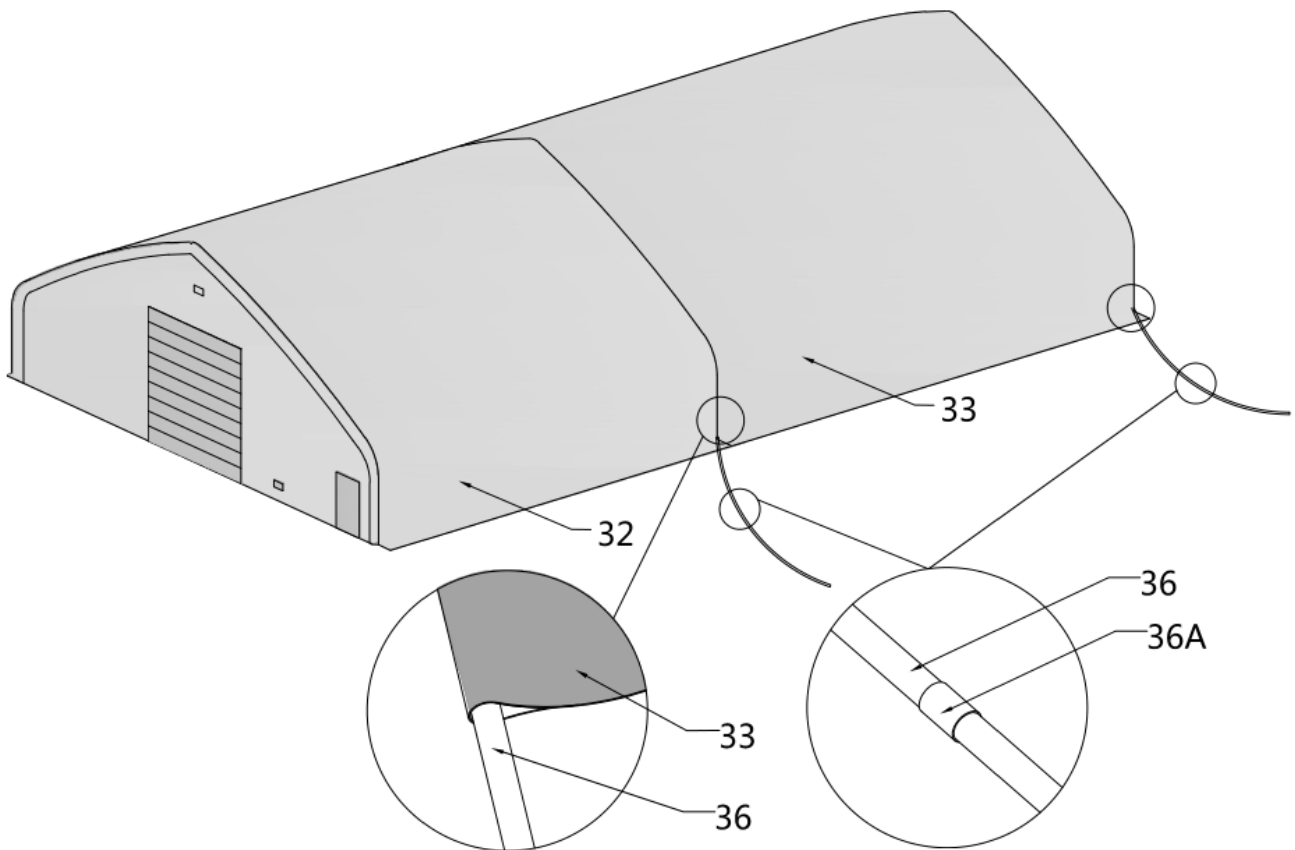
2. INSTALL THE TOP COVER B (#33).





NO.	PART	QTY
36		16
36A		14

STEP 18 :

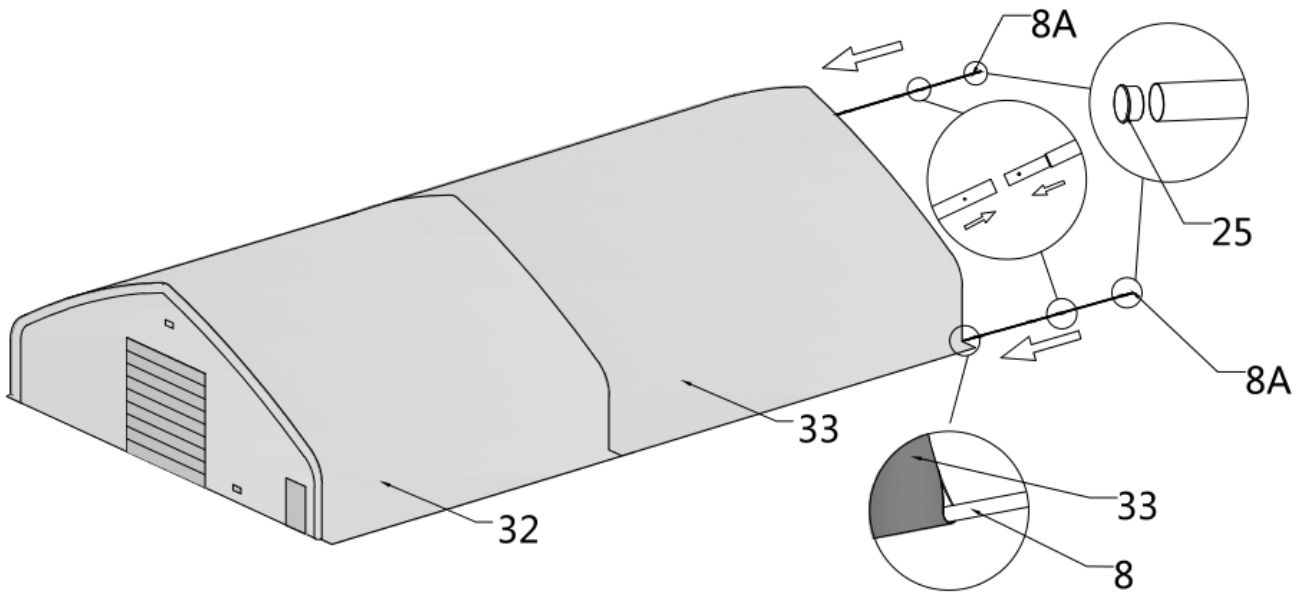
3. INSTALL THE TOP COVER B (#33).

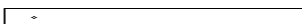



NO.	PART	QTY
8		16
8A		2
25		4

STEP 18 :

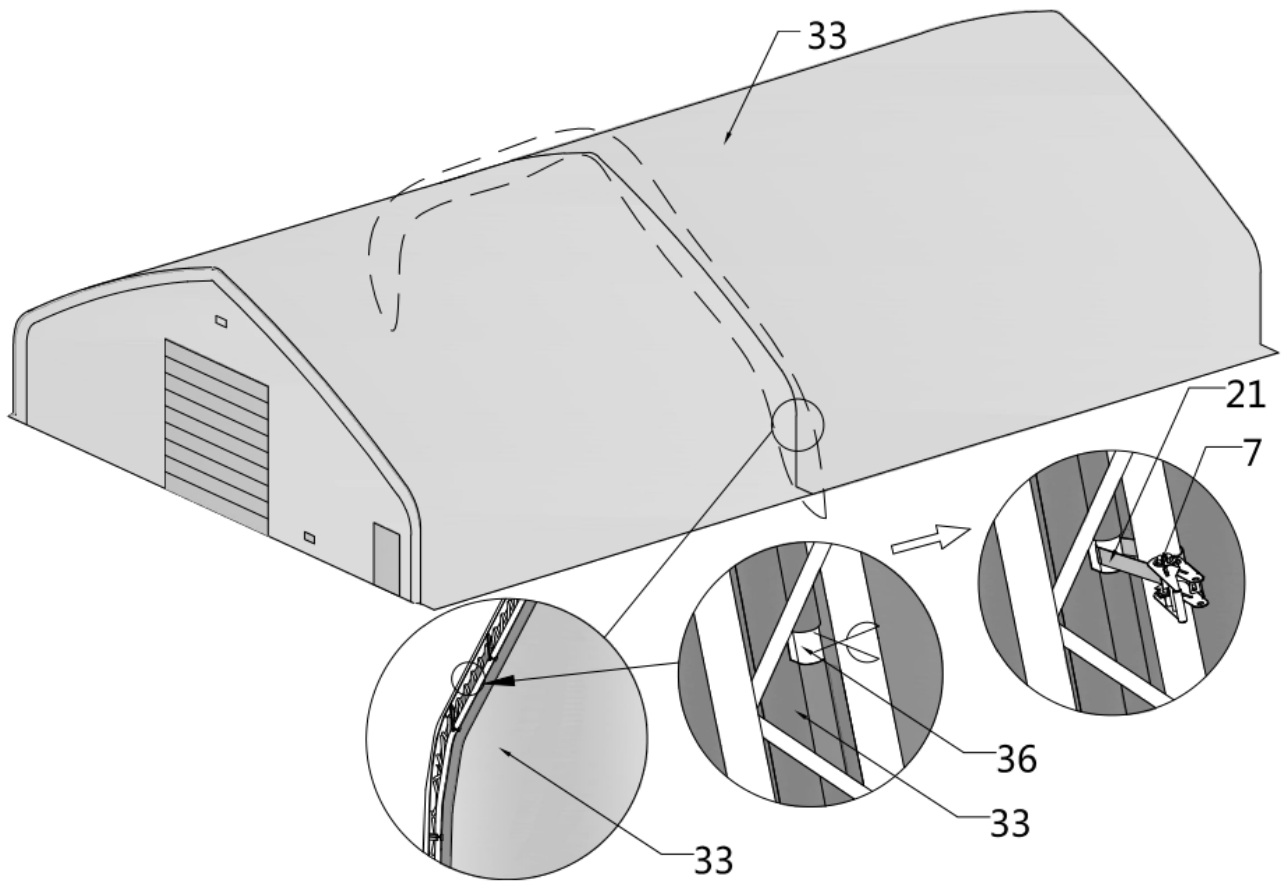
4. INSTALL THE TOP COVER B (#33).





NO.	PART	QTY
7		24
21		24

STEP 18 :

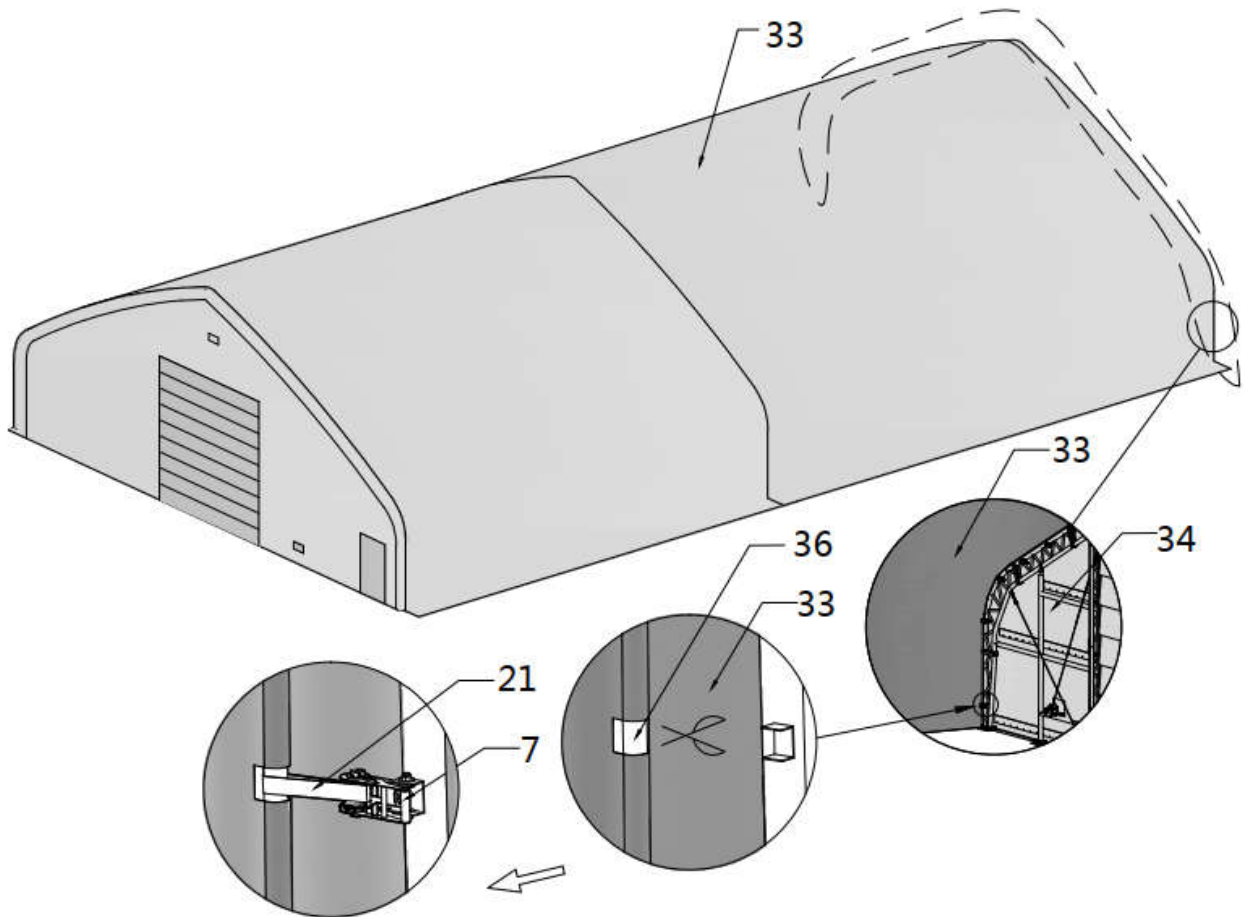

5. INSTALL THE TOP COVER B (#33).

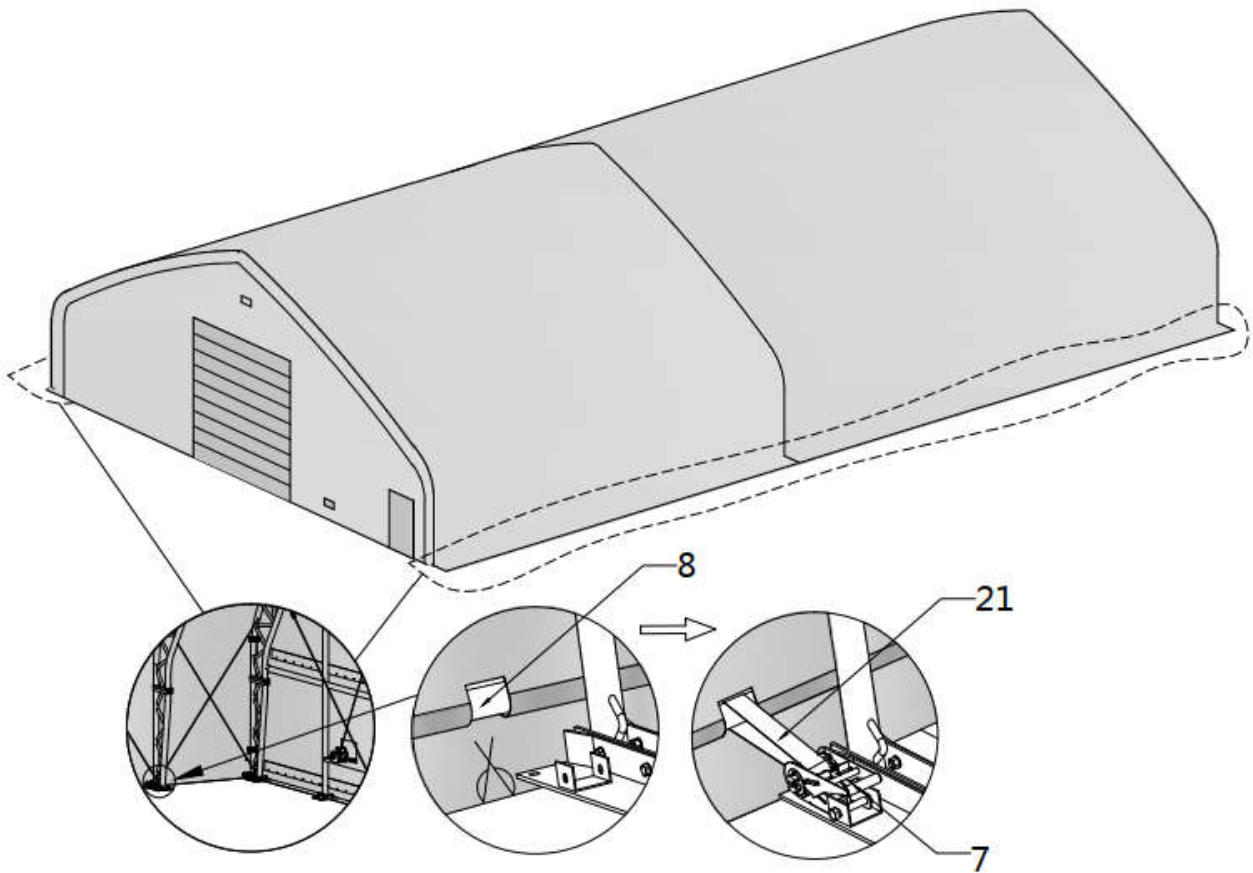

NO.	PART	QTY
7		24
21		24

STEP 19 : TENSION BOTH SIDES OF THE TOP CLOTH WITH THE TENSION DEVICE.



NO.	PART	QTY
7		34
21		34

STEP 20 : TIE THE ROPE.

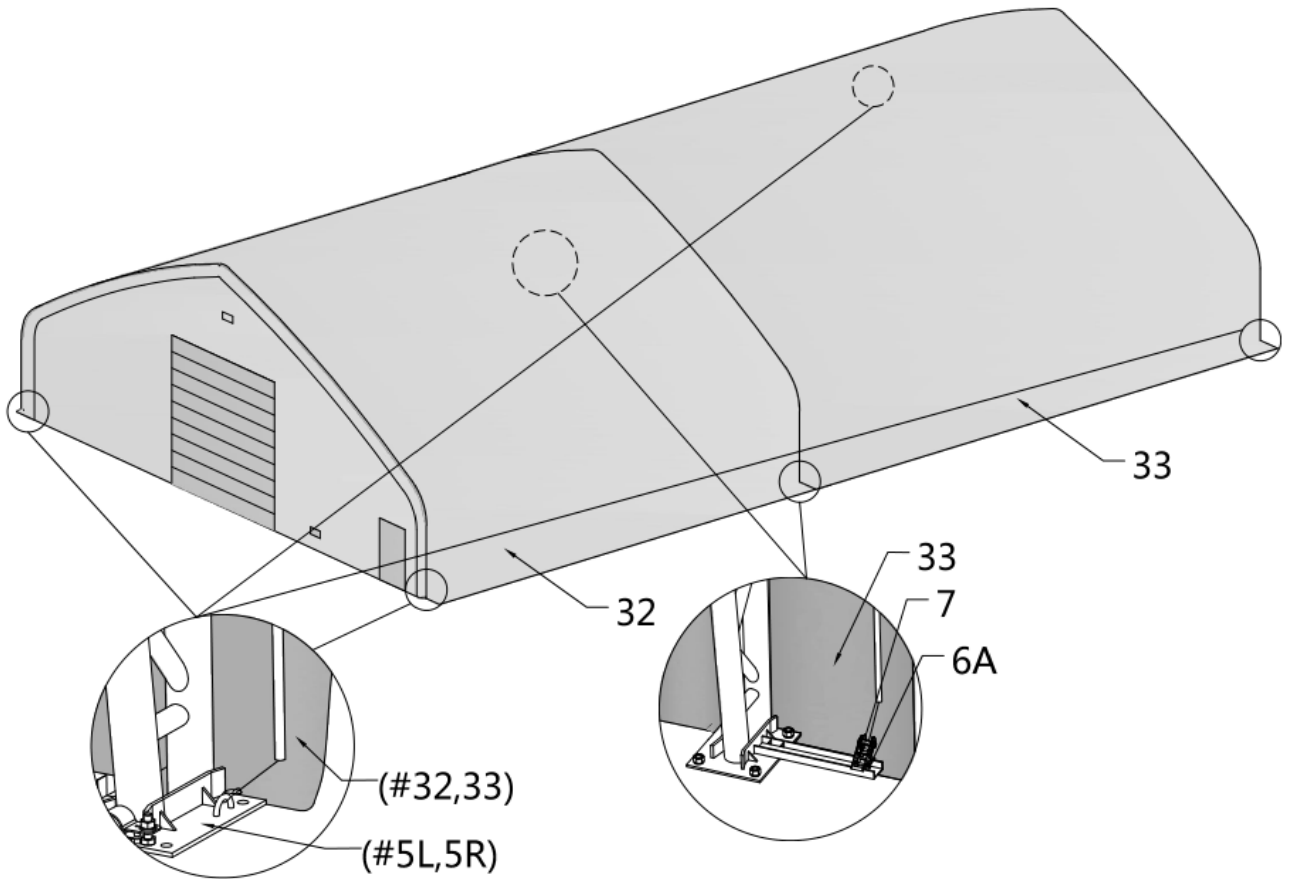

NO.	PART	QTY
7		2

AFTER THE INSTALLATION

Walk around and inspect the building periodically to make sure all components are still firmly secured and the whole building is well supported. Check all bolts and nuts as well as all connection points to make sure they are all in good position. Check the base plates, adjust the ropes and tie downs if required and clean the cover regularly.

Snow accumulating on the fabric cover must be removed as soon as possible. If snow becomes solid ice on the cover, it will increase the weight on the roof and collapses the building or reduce the life span eventually.

Keep the building on a dry ground most of the time. Do not keep the fabric dirt skirt under water all the time, otherwise the fabric will deteriorate.

We strongly recommend you remove any snow from the roof immediately. Do not leave any snow load on the roof overnight. Keep 3 feet of clearance on all sides at all times. Do not allow snow to accumulate and pile up on the sides of the building. Otherwise the push from the sides toward inside will make the building collapsed at some point.

WARRANTY INFORMATION:

Please refer to our website for detailed warranty conditions and coverage.
For the most up-to-date and comprehensive warranty information, visit www.tmgindustrial.com