

# 50' X 40' DUAL TRUSS CONTAINER HOOP SHELTER

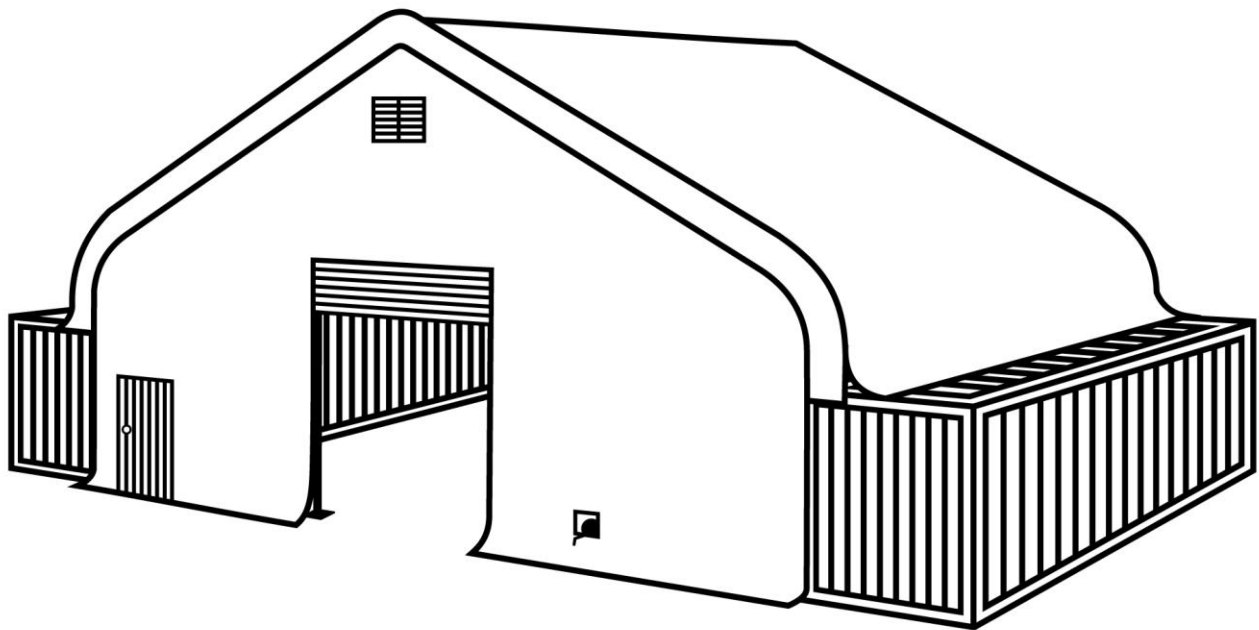

## ⚠ WARNING



- Please read and understand the product manual completely before assembly
- Check against the parts list to make sure all parts are received
- Wear proper safety goggles or other protective gears while in assembly
- Do not return the product to dealer. They are not equipped to handle your requests.

Missing parts or have questions on assembly?  
Please call: 1-877-761-2819 or email: [cs@tmgindustrial.com](mailto:cs@tmgindustrial.com)

## MAIN SPECIFICATIONS :

- Assembly size : W15.24 x L12 x H7.8 (m) / 50 x 40 x 25.6 (ft)
- Outside width : 15.24 m / 50ft, inside width : 14.4 m / 47.4 ft, length : 12 m / 40 ft
- Ridge peak height : 7.8 m / 25.6 ft
- Peak clearance height : 7.2 m / 23.6 ft

It is your option to pick and call the smaller door side as front or rear, then the wider door side will be called in an opposite way.

## PRIOR TO ASSEMBLY

Please go through the whole instruction manual completely. It is very important to follow your local safety regulations and industry standards during installation. Regulations may include but are not limited to:

- Safety helmets, protective eyewear, and clothing
- Safety harnesses for all elevated workers
- Proper ladder, cage, and safety operation

Check all components and parts before installation. All parts are marked with a part number, please refer to the parts list to ensure you have all parts.

Choose a day with low or no wind to install, it is hard to assemble with heavy wind. Do not make any alterations to the structure. Do not hang any weight on the frame during installation, including parts. We are not responsible for any damages or injuries caused by inappropriate installation, unauthorized modifications or extreme weather.

This building is not intended for human occupancy.





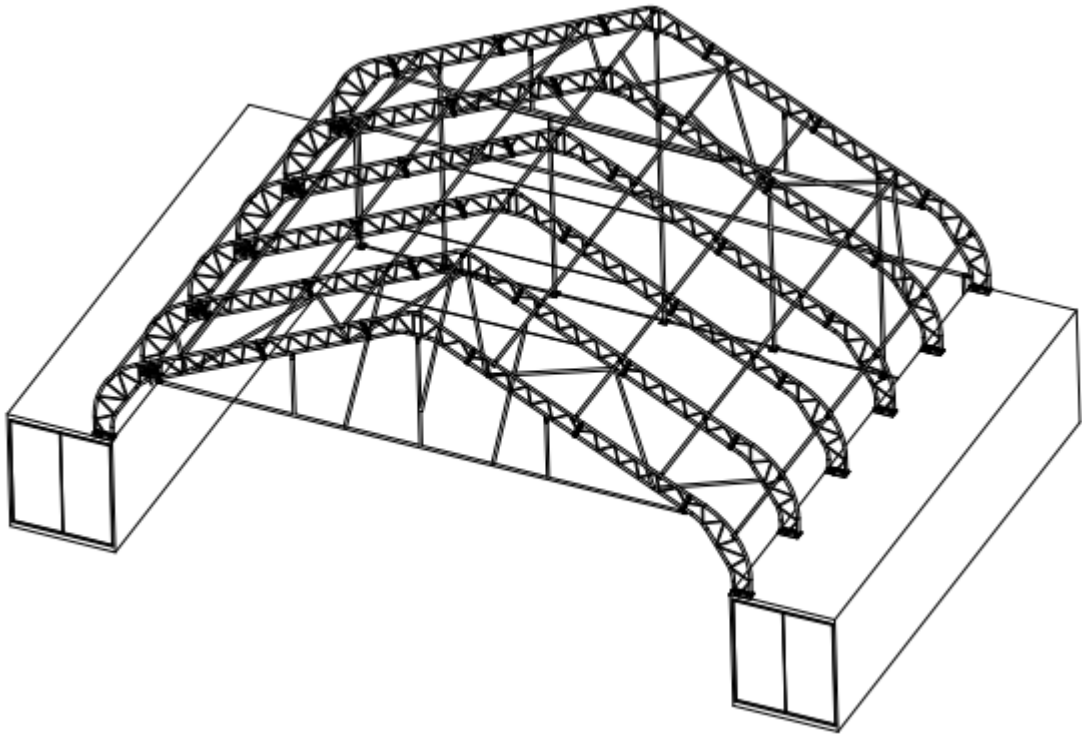

It is recommended to use heavy duty duct tapes to tape the tube connection joint spots to protect the cover from damage and worn. It will help to extend the cover life span.





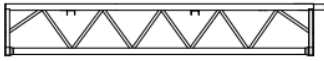
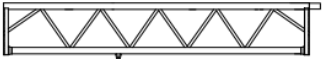
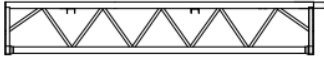
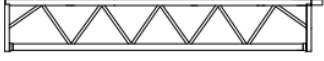
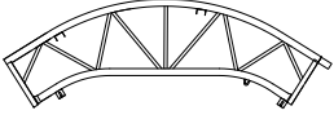
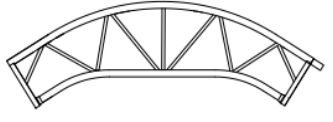



Check the parts list below to make sure all parts are received prior to assembly.

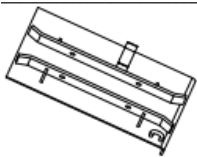
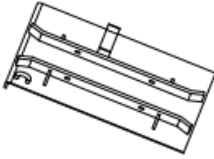
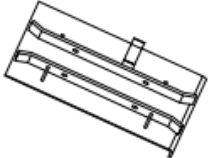

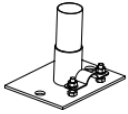
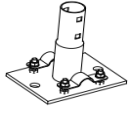







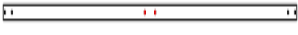
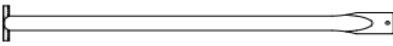
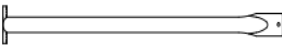

**FRAME STRUCTURE DIAGRAM.**

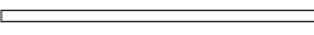





TMG-DT5040CF-PRO Part List

PARTS CODE	GRAPHICAL	DESCRIPTION	LENGTH	QTY	BOX
1A		Peak arch tube (for front and rear truss)	L2646mm	2	B
1		Peak arch tube (for 4 middle trusses )	L2646mm	4	A
2A		Upper rafter tube (for front and rear truss)	L2855mm	4	A
2		Upper rafter tube (for middle truss)	L2855mm	8	A
3A		Lower rafter tube (for front and rear truss)	L2855mm	4	A
3		Lower rafter tube (for middle truss)	L2855mm	8	A
4A		Shoulder tube (front and rear truss)	L2613mm	4	B
4		Shoulder tube (for middle truss)	L2613mm	8	B
5B		Roof purl in (horizontal tube)	φ58xL2440mm	45	A
5C		Front and rear wall and front and rear span tube	φ58xL2890mm	18	A
5D		Front and rear wall tube	φ58xL2840mm	4	B

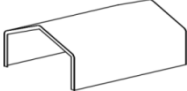
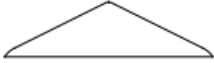
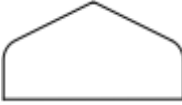
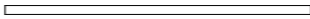
5L		Base plate for front and rear truss left corners	W230xL479mm	2	B
5R		Base plate for front and rear truss right corners	W230xL479mm	2	B
6		Base plates for middle truss	W230xL479mm	8	B
6A		Ratchets	3T	44	B
6B		Tie down straps (for #7A and front and rear arches)	W38x800mm	44	B
7		Baseplate	W150xL200mm	2	B
7A		Baseplate	W150xL200mm	5	B
8		Lower vertical tube (rear wall)	φ58xL2703mm	5	A
8A		Lower vertical tube (rear wall left and right)	φ58xL2693mm	2	A
9		Upper vertical tube (rear wall)	φ58xL1990mm	4	A
9A		Middle vertical tube (rear wall middle)	φ58xL2022mm	1	A
10		Lower transverse tube (rear wall middle)	φ58xL2270mm	2	B
10A		Lower transverse tube (rear wall left and right)	φ58xL2367mm	2	B

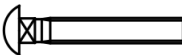
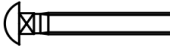
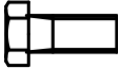
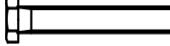
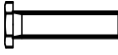
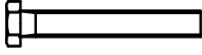
10B		Lower transverse tube (rear wall left and right)	φ58xL2461mm	2	A
11		Upper transverse tube (rear wall left and right)	φ58xL2890mm	4	A
11A		Upper transverse tube (rear wall left and right)	φ58xL2020mm	4	A
12		Upper transverse tube (rear wall middle)	φ58xL2890mm	2	A
13		Upper vertical tube (rear wall middle)	φ58xL2828mm	2	B
14		Upper vertical tube (rear wall left and right)	φ58xL1565mm	4	A
15		Bottom tension bar (rear wall)	φ58xL2310mm	4	B
15A		Bottom tension bar (rear wall)	φ58xL2215mm	2	B
15B		Rear door cloth fixing tube	φ58xL2400mm	2	B
15C		Fixings (for #15B)	W50xL50mm	4	B
16B		Ridge steel tension cables (middle trusses)	φ6xL5400mm	4	B
17		Top cover tension tube (for both bottom sides)	φ32xL1993mm	12	B
17A		Top cover tension tube (for both bottom sides)	φ32xL500mm	2	B
18		Tube clamps	φ58mm	42	B
19		Tension tube end water plug	φ32mm	20	B
20		Braided rope (tie to front and back doors)	φ8xL200m	1	B

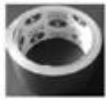
21		Roof fabric tarp cover		1	B
22		Front truss fabric cover panel		1	B
22A		Rear truss fabric cover panel		1	B
23		Plastic hose (in grooves at both ends of #24)	φ25xL4000mm	10	B
24		Connector (for connection #23)	φ25mm	8	B
25		Expansion bolts	φ16x150mm	14	B
26		Self locking bolt and nuts	M10x80mm	54	B
27		Self locking bolt and nuts	M8x70mm	40	B
28		Hex bolt and nuts	M12x30mm	192	B
29		Hex bolt and nuts	M10x80mm	10	B
30		Hex bolt and nuts	M10x50mm	50	B
31		Hex bolt and nuts	M10x100mm	12	B
32		Tapping screw	#12x25mm	12	B
32		Scratch resistant tape	L10m	3	B

**STEP 1 : BASEPLATE POSITIONING AND INSTALLATION.**

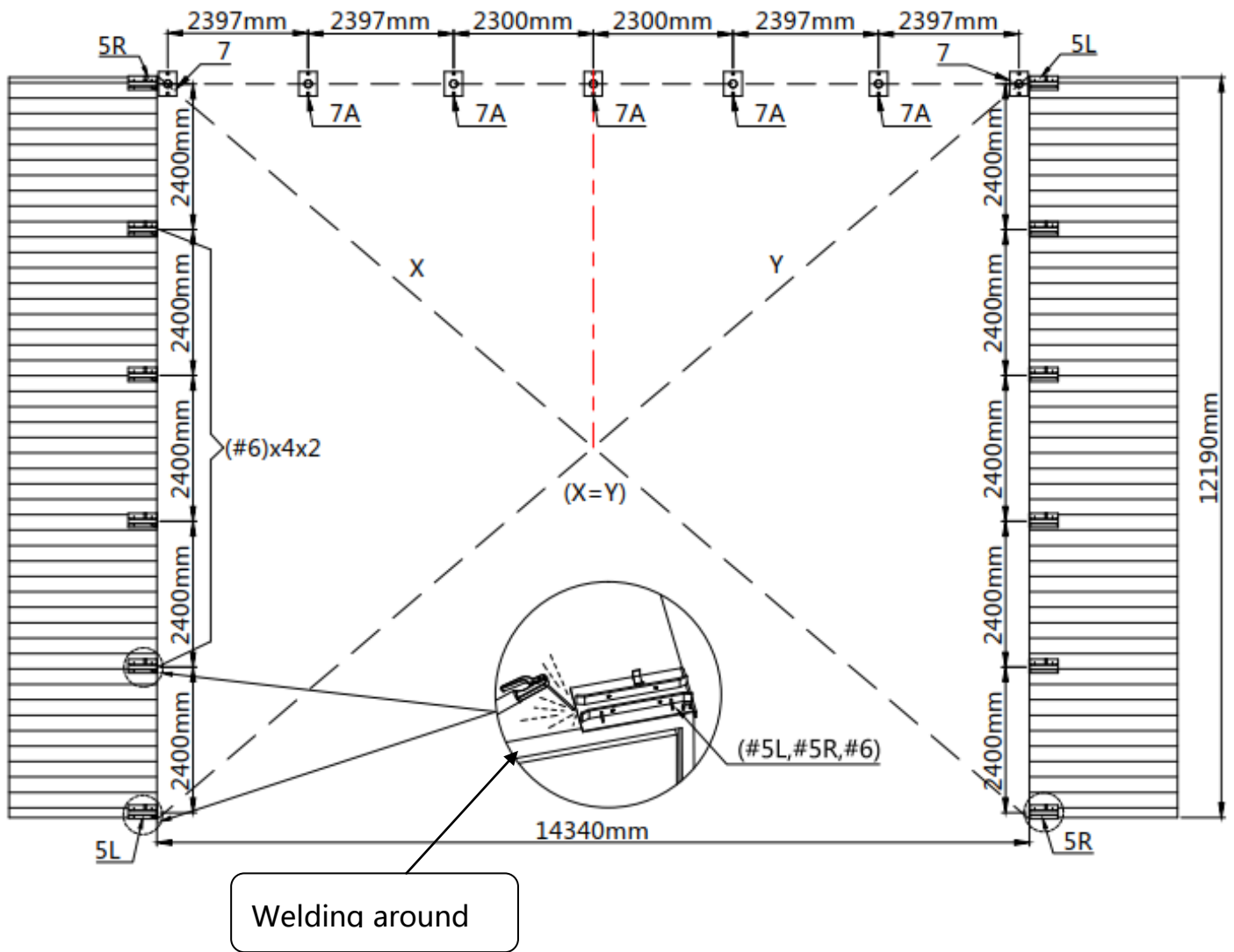





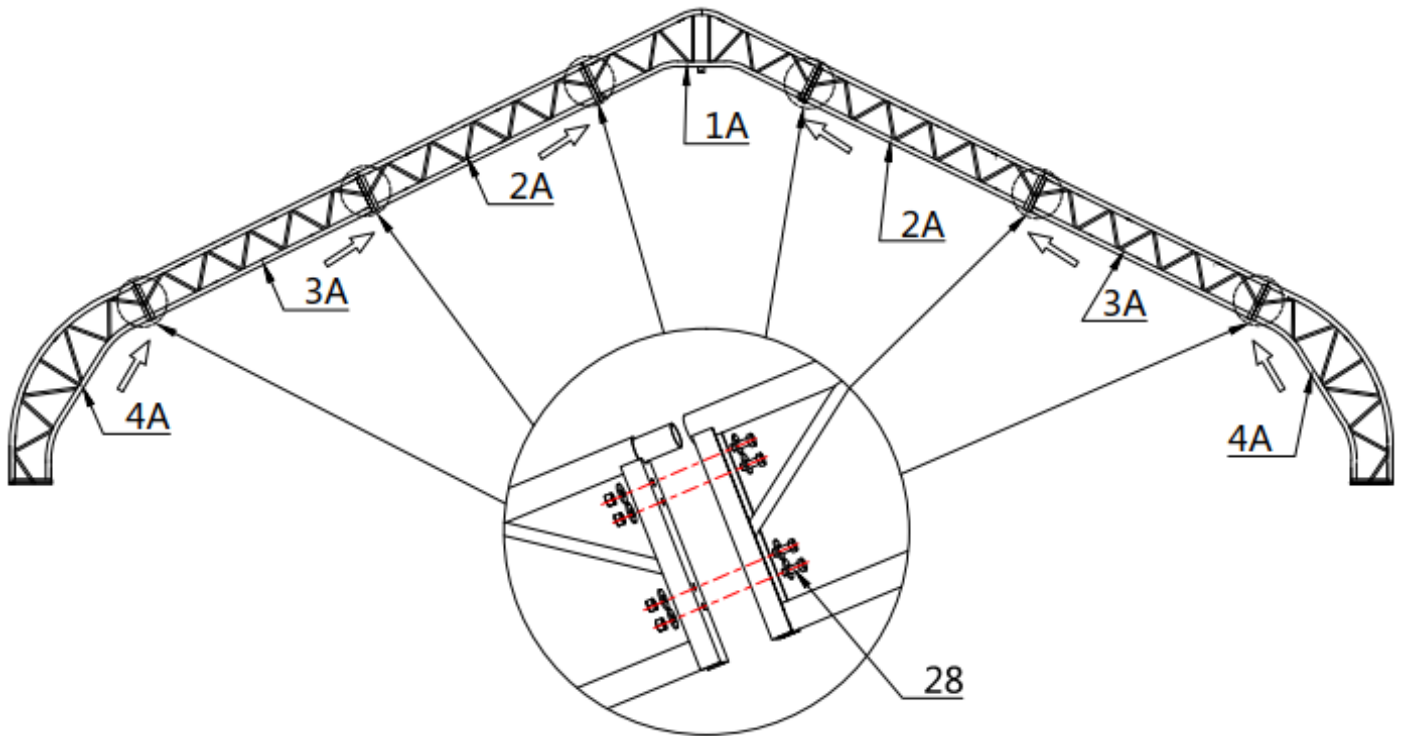

PARTS CODE	PART	QTY
5L		2
5R		2
6		8

PARTS CODE	PART	QTY
7		2
7A		5
25		14









**STEP 2 : INSTALLATION OF FRONT AND REAR 2 GROUP TRUSSES.**

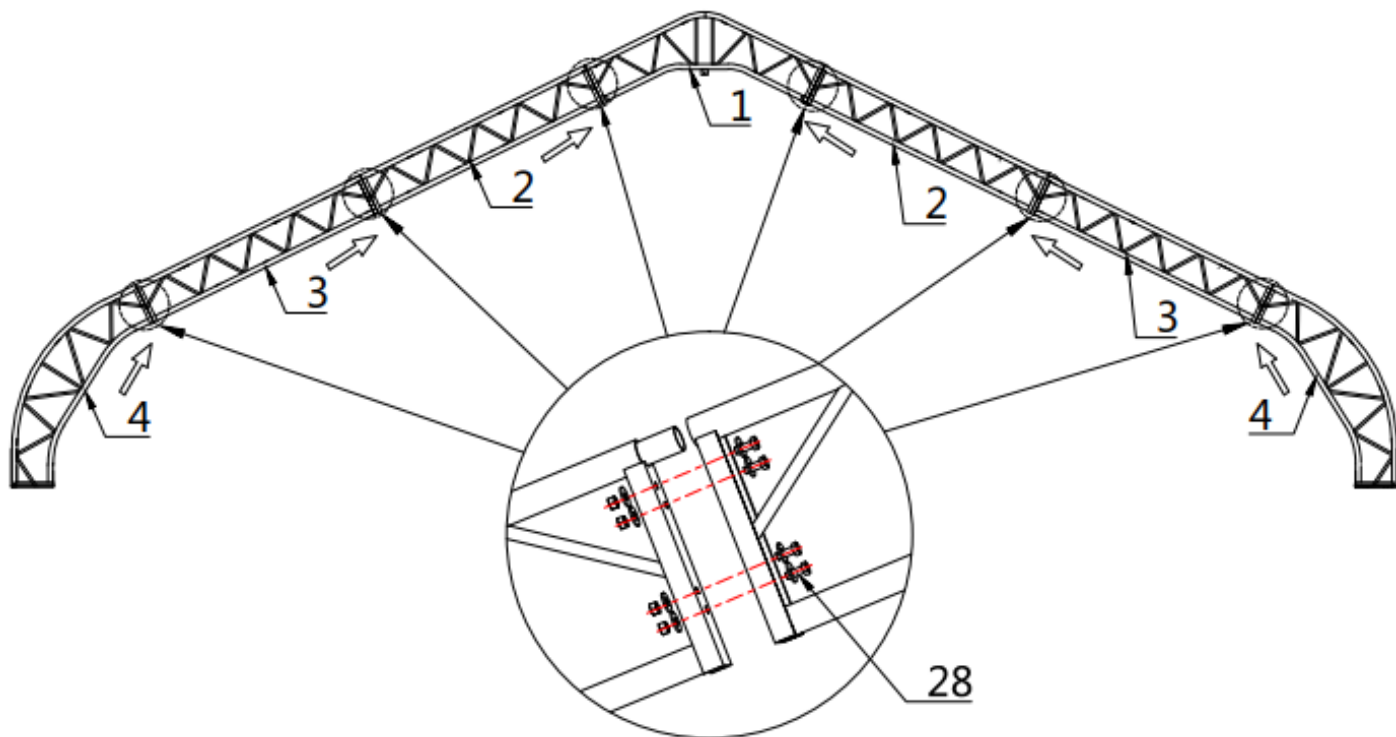

PARTS CODE	PART	QTY
1A		1x2
2A		2x2
3A		2x2
4A		2x2
28		24x2

**STEP 3 : INSTALLATION OF MIDDLE 4GROUP TRUSS.**



PARTS CODE	PART	QTY
1		1x4
2		2x4
3		2x4
4		2x4
28		24x4

**STEP 4 : WRAP (#23) AROUND THE SHARP POINTS OF THE JOINT TO AVOID FRICTION BETWEEN THE FABRIC AND THE INTERFACE.**

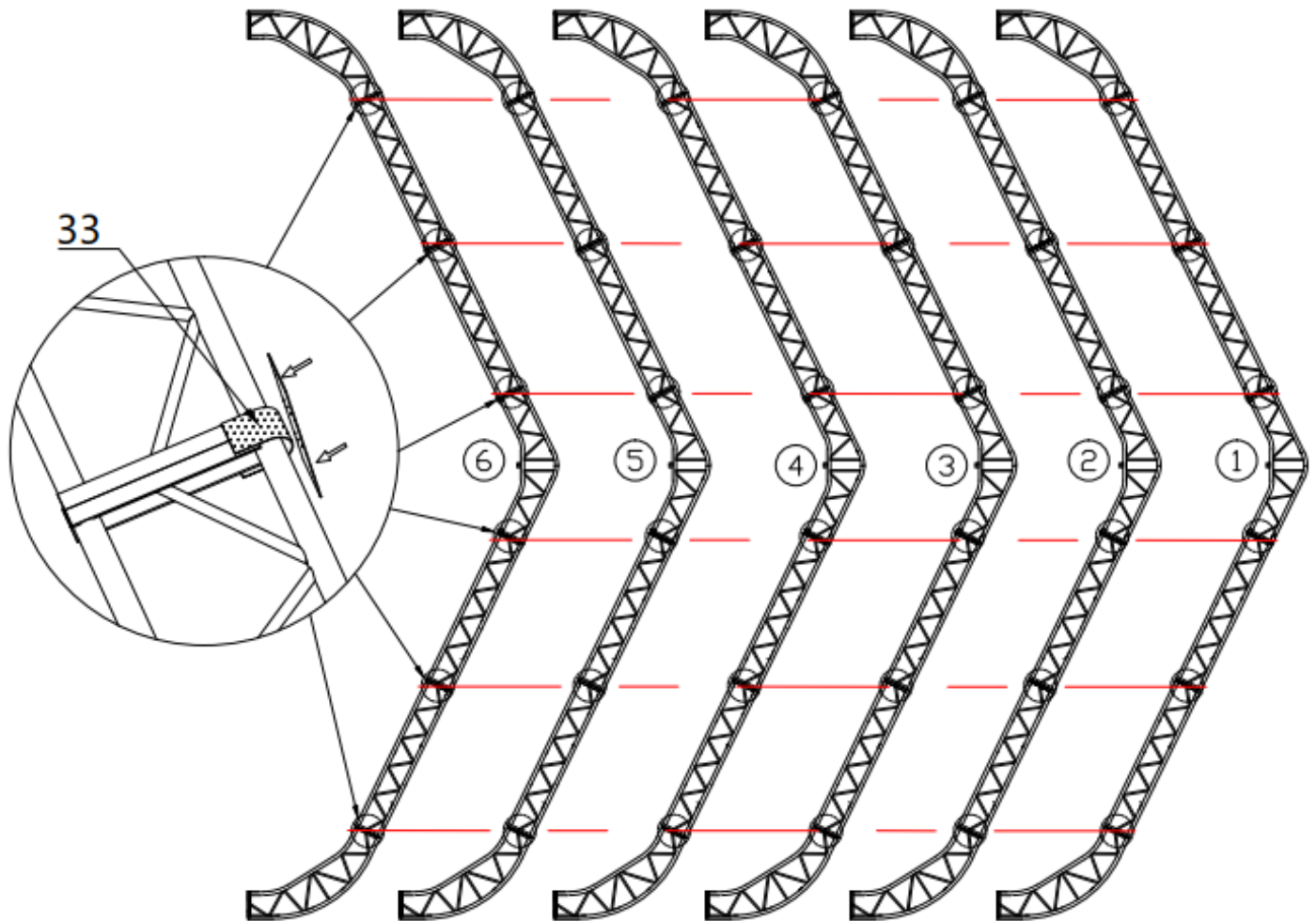

PARTS CODE	PART	QTY
33		3

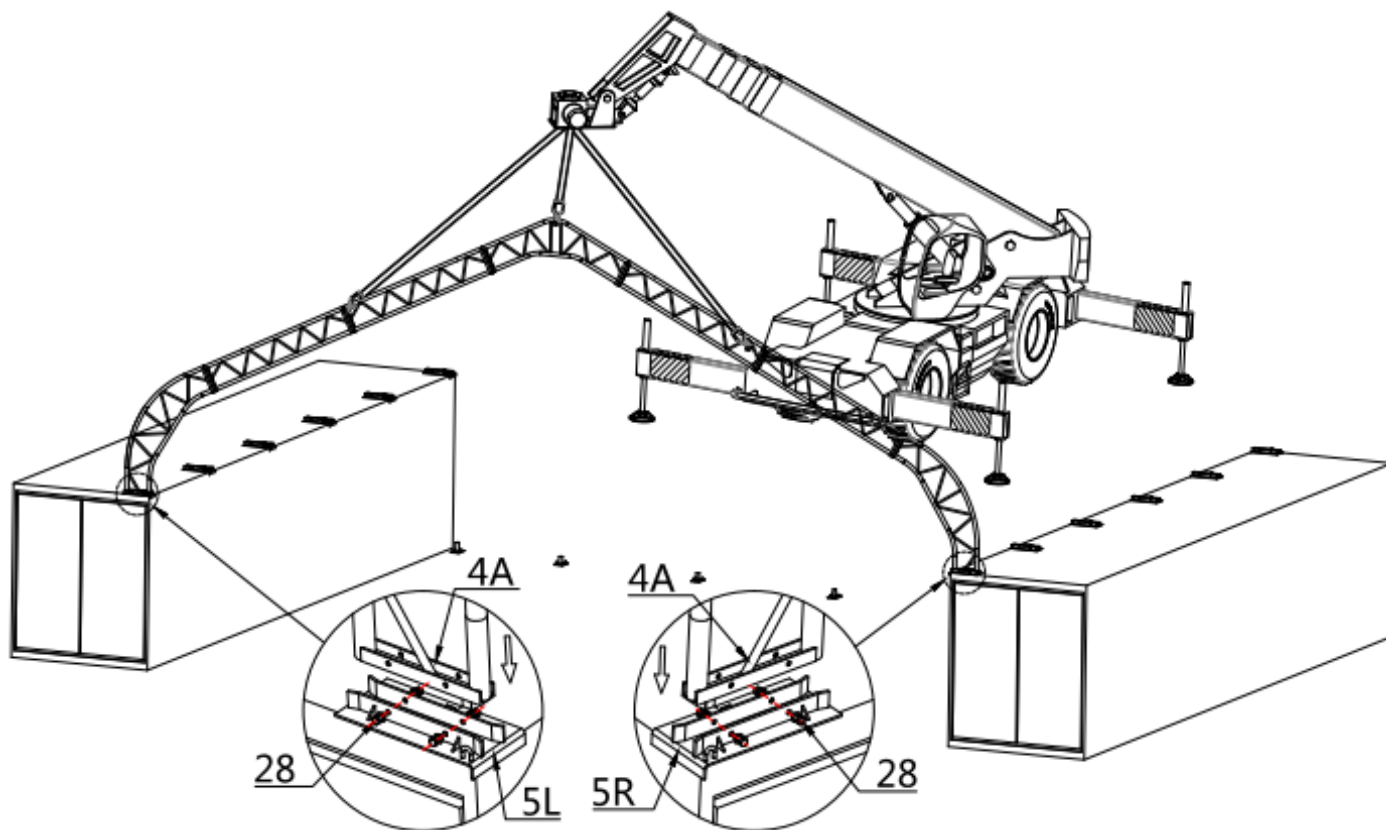

STEP 5 : PUT UP THE FRONT TRUSS(IT IS SUGGESTED TO USE CRANE FOR HOISTING).

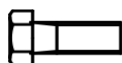

PARTS CODE	PART	QTY
28		8

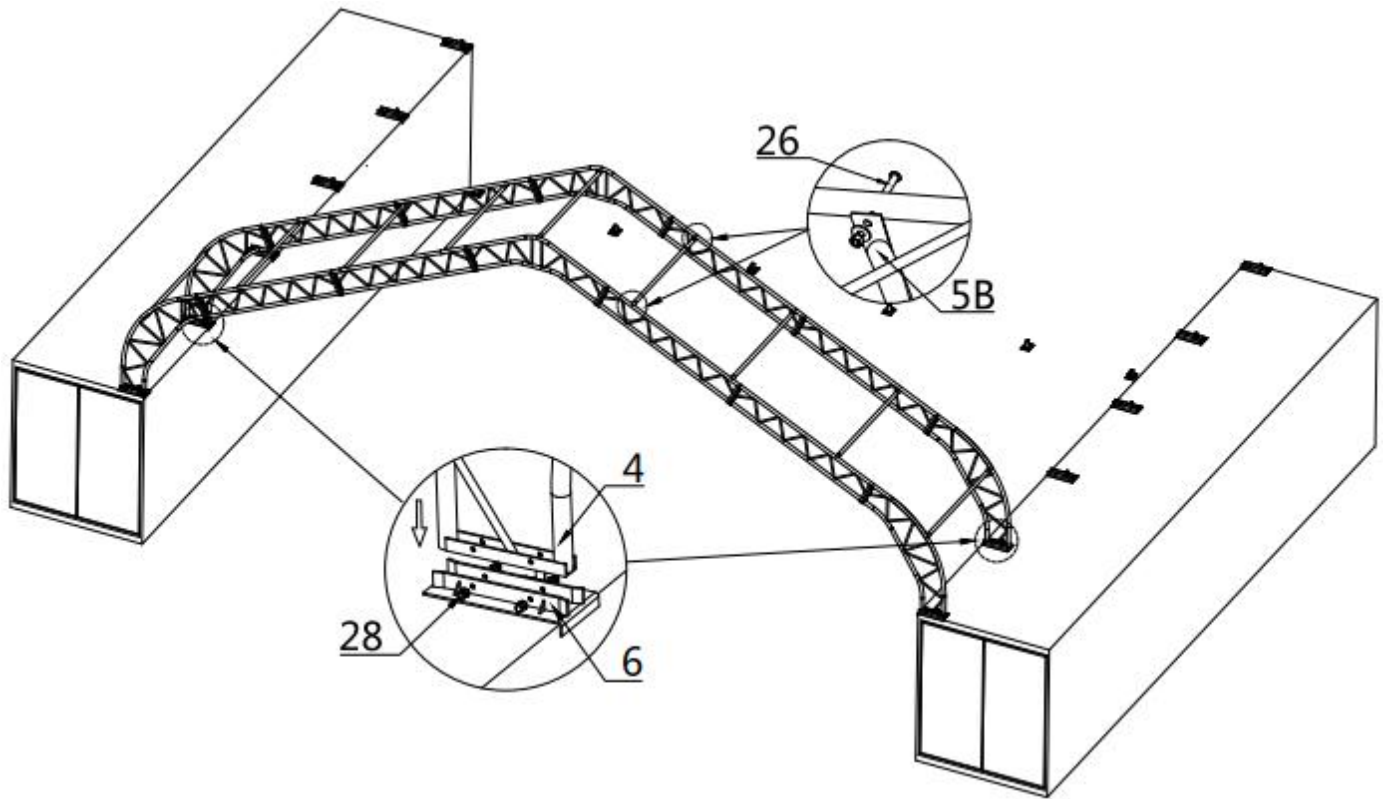

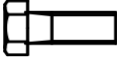
**STEP 6 : PUT UP THE 2ND TRUSS, AND CONNECT ALL PURLINS (#5B) BETWEEN 1ST AND 2ND.**



PARTS CODE	PART	QTY
5B		9
28		8
26		18

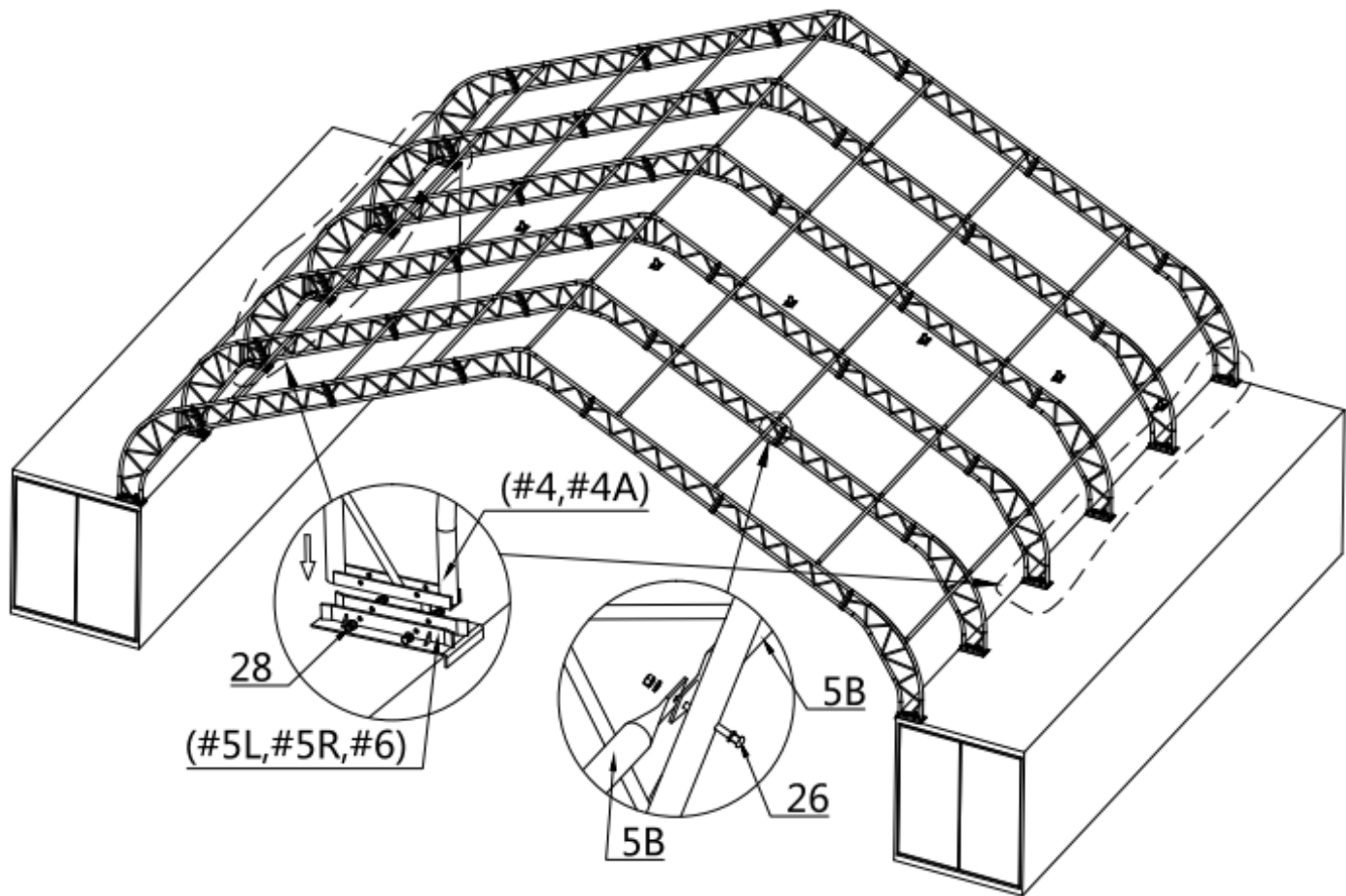

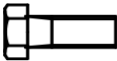
STEP 7 : REPEAT ABOVE STEP TO PUT UP ALL OTHER TRUSSES , AND CONNECT ALL PURLINS.



PARTS CODE	PART	QTY
5B		36
28		32
26		36

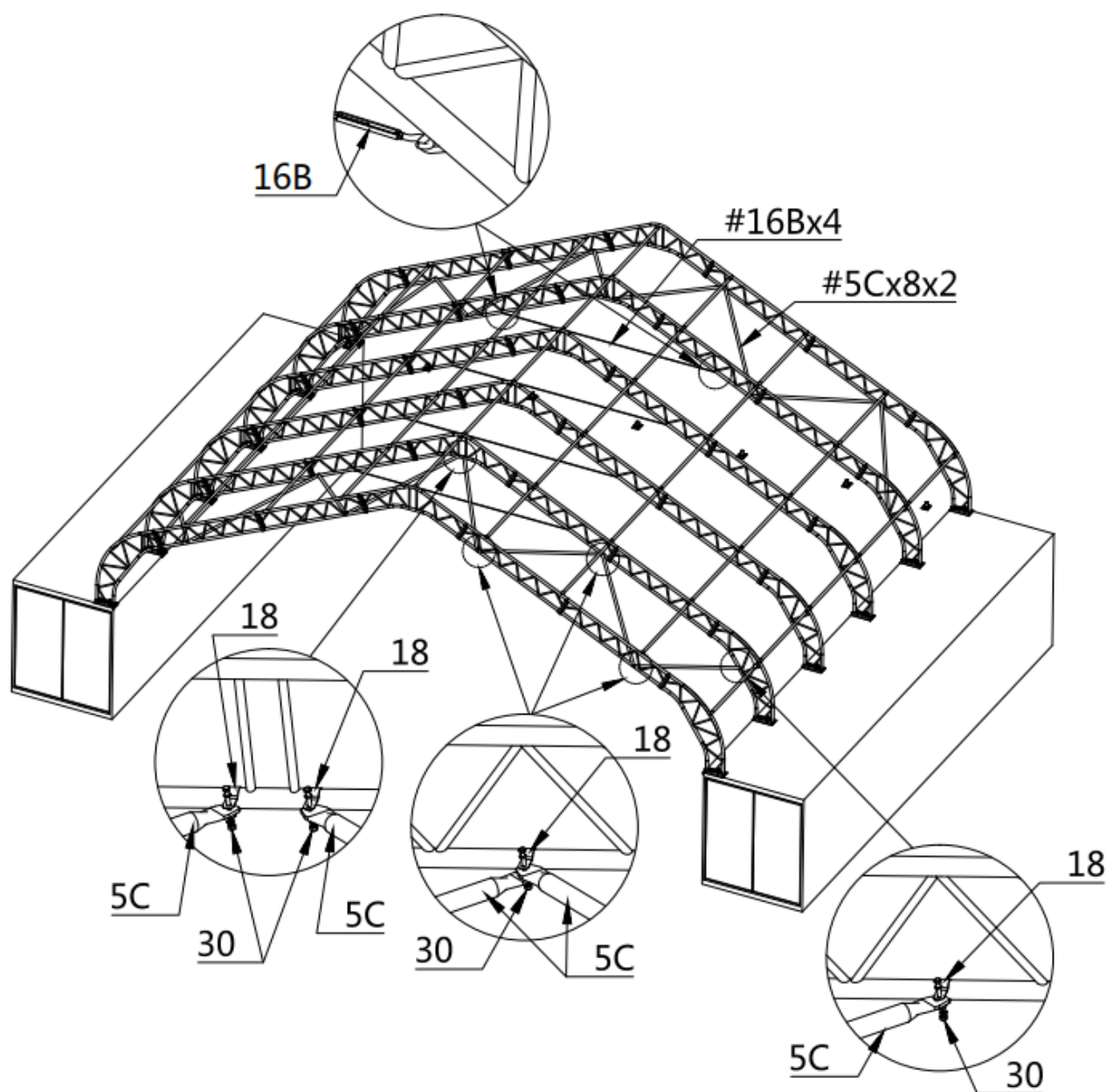



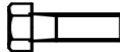

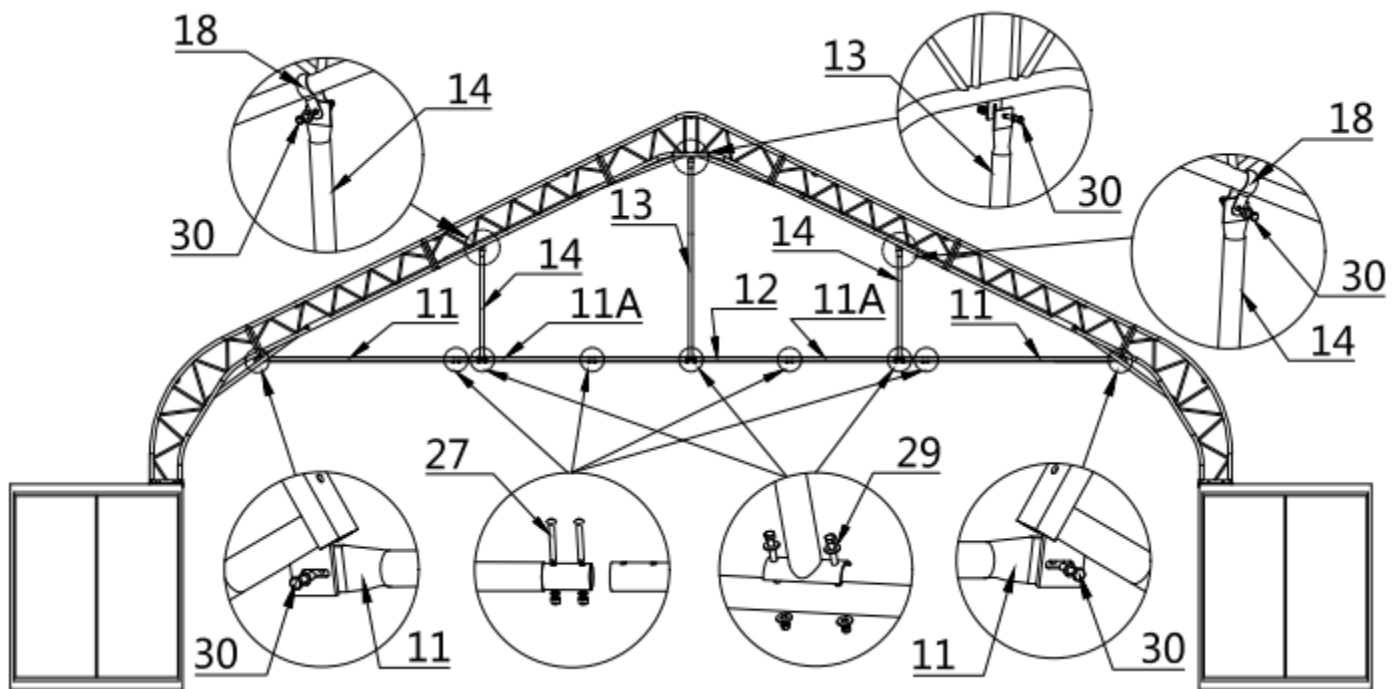

**STEP 8 : INSTALLATION OF INCLINED PURLIN INSTALLATION AND TENSION CABLE.**

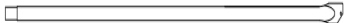

PARTS CODE	PART	QTY
5C		16
16B		4
18		20
30		20

**STEP 9 : INSTALL THE UPPER SUPPORT TUBE OF THE FRONT TRUSS.**









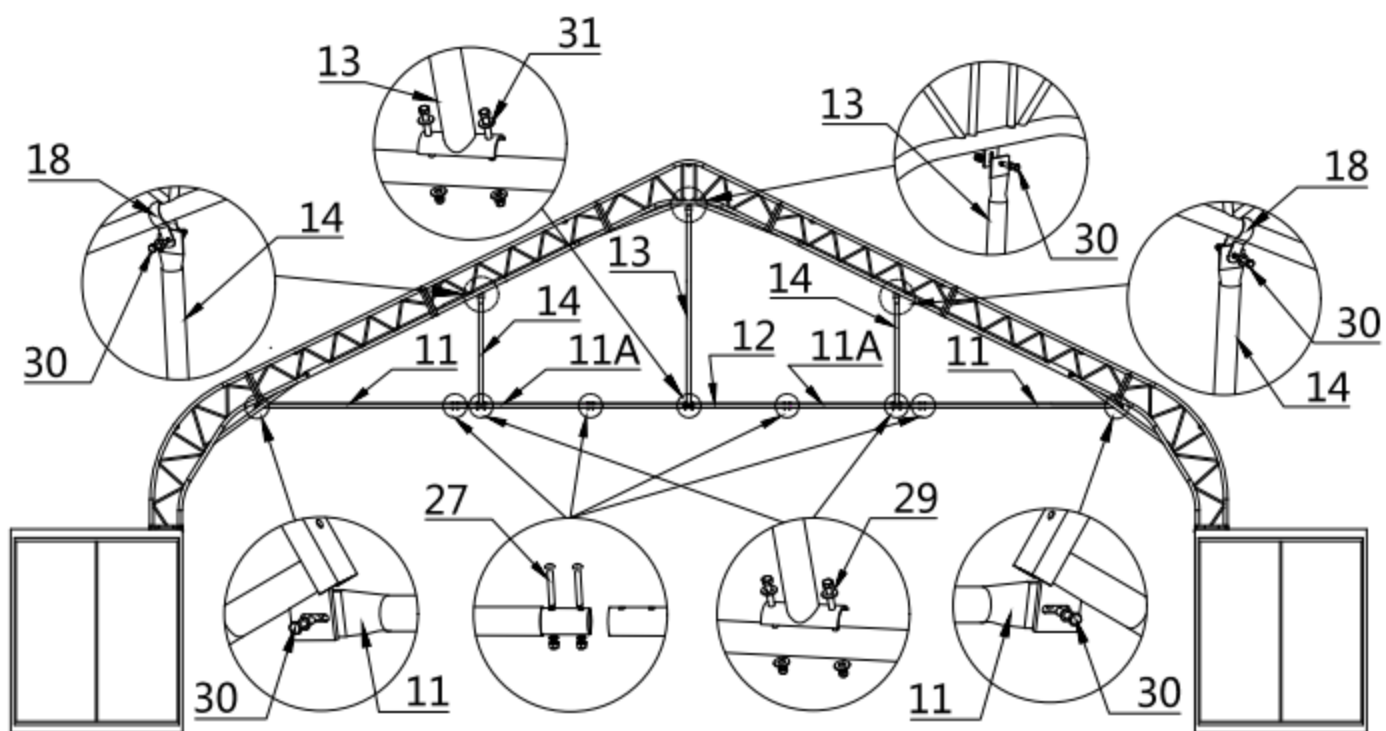

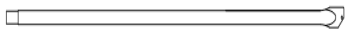

PARTS CODE	PART	QTY
11		2
11A		2
12		1
13		1
14		2
18		2
27		8
29		6
30		5



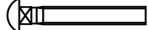

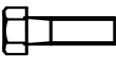

**STEP 10 : INSTALL THE UPPER SUPPORT TUBE OF THE REAR TRUSS.**

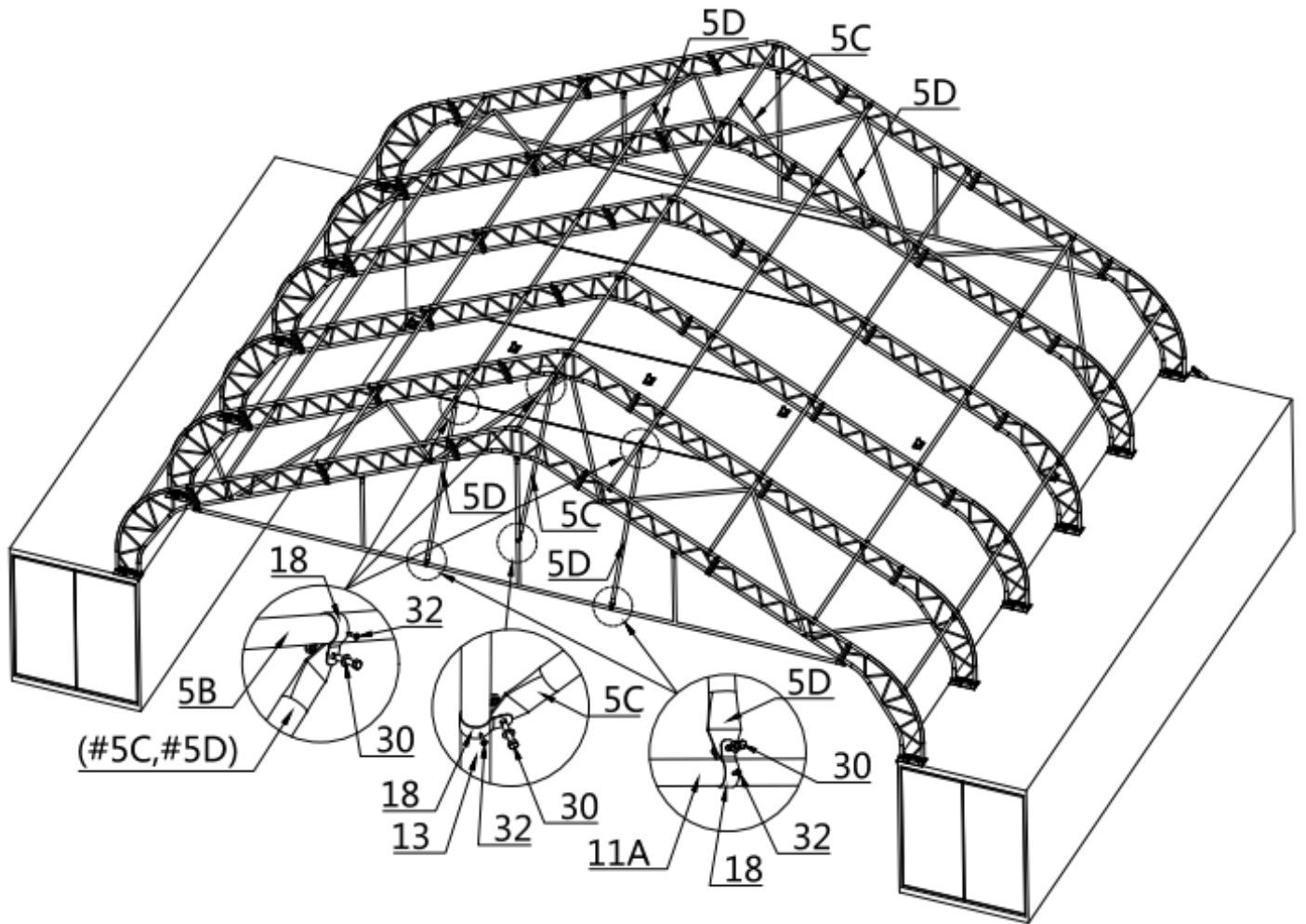

PARTS CODE	PART	QTY
11		2
11A		2
12		1
13		1
14		2
18		2
27		8
29		4
30		5
31		2

**STEP 11 : INSTALL VERTICAL DIAGONAL SUPPORT PIPE (#5C, #5D) (THE FRONT AND REAR MOUNTING METHODS ARE THE SAME).**



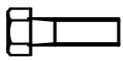
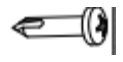



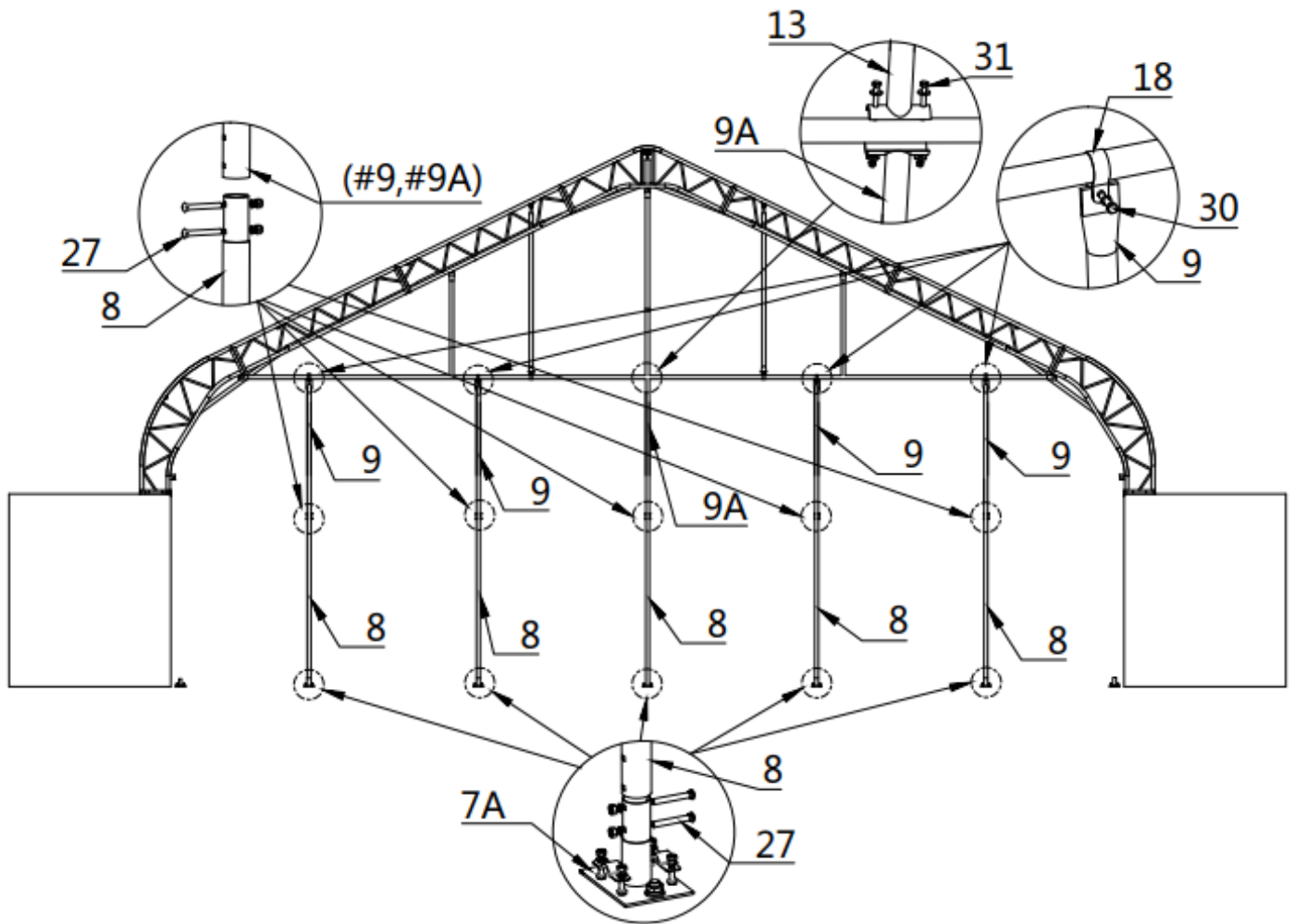

PARTS CODE	PART	QTY
5C		1x2
5D		2x2
18		6x2
30		6x2
32		6x2

**STEP 12 :**

**1. INSTALL THE REAR LOWER SUPPORT PIPE.**



PARTS CODE	PART	QTY
8		5
9		4
9A		1
18		4

PARTS CODE	PART	QTY
27		20
30		4
31		2

**STEP 12 :**

**2. INSTALL THE REAR LOWER SUPPORT PIPE.**

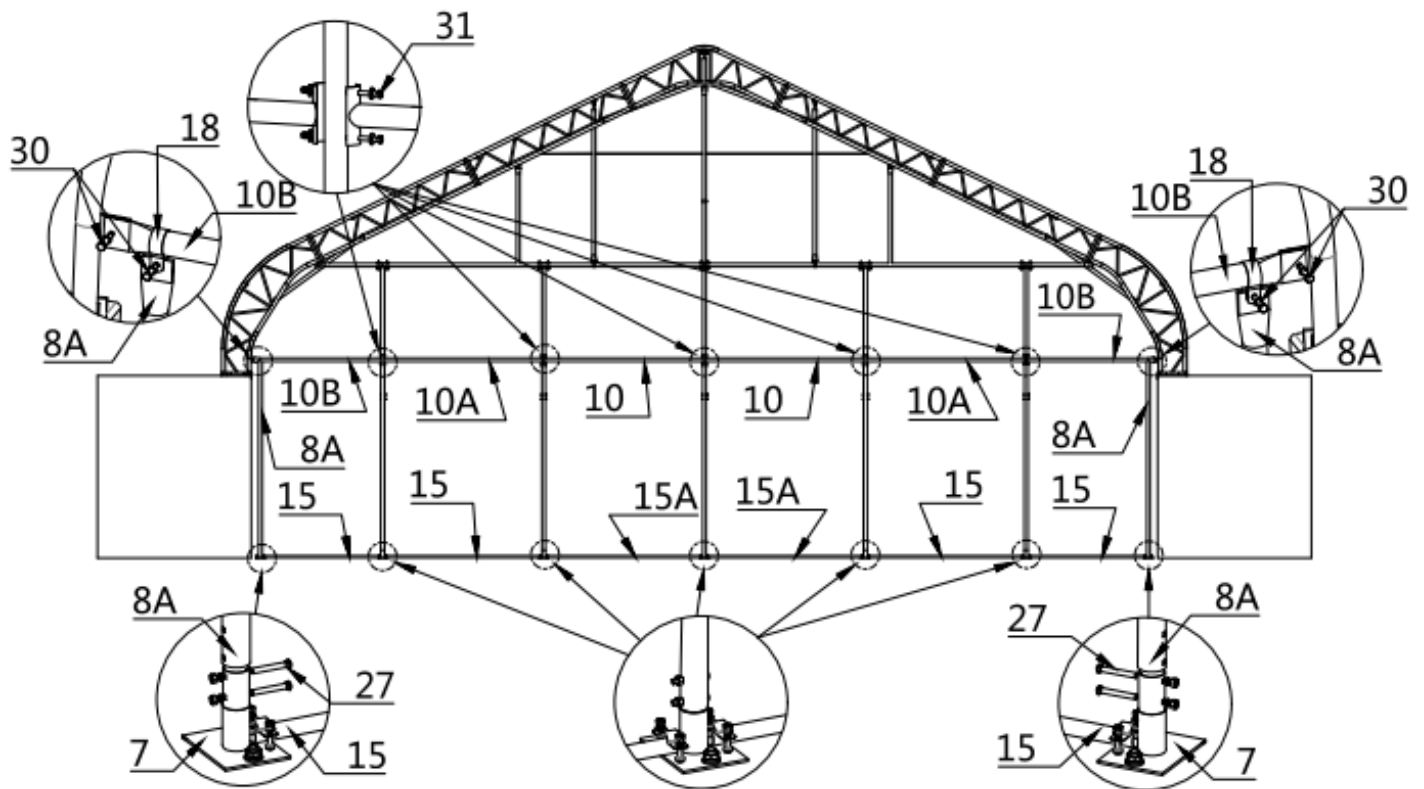





PARTS CODE	PART	Qty
8A		2
10		2
10A		2
10B		2

PARTS CODE	PART	QTY
15		4
15A		2
18		2
27		4

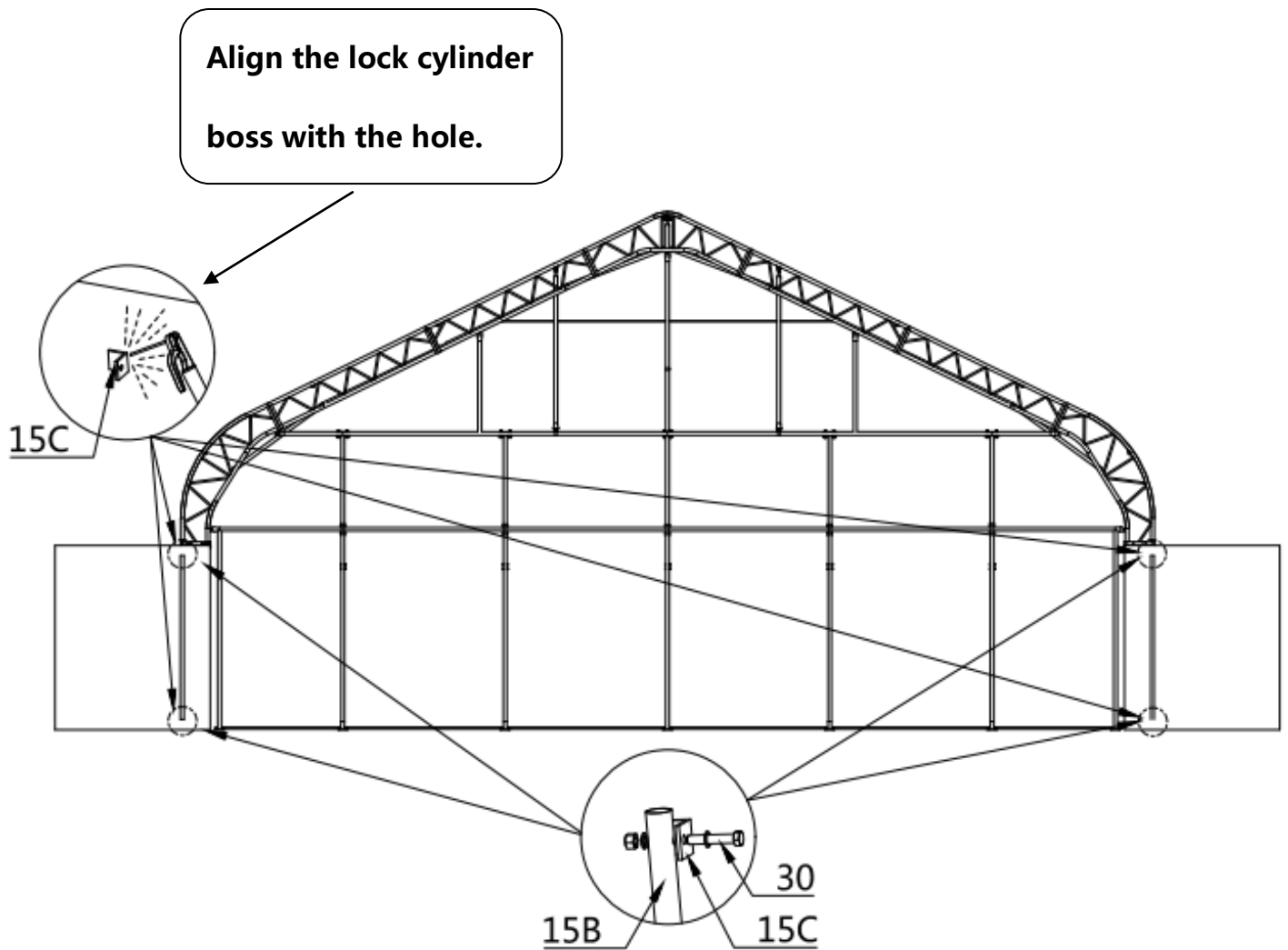
PARTS CODE	PART	QTY
30		4
31		10

**STEP 13 : INSTALL (#15B).**



PARTS CODE	PART	QTY
15B		2
15C		4
30		4

**STEP 14 : INSTALL THE WATERPROOF PLUG.**

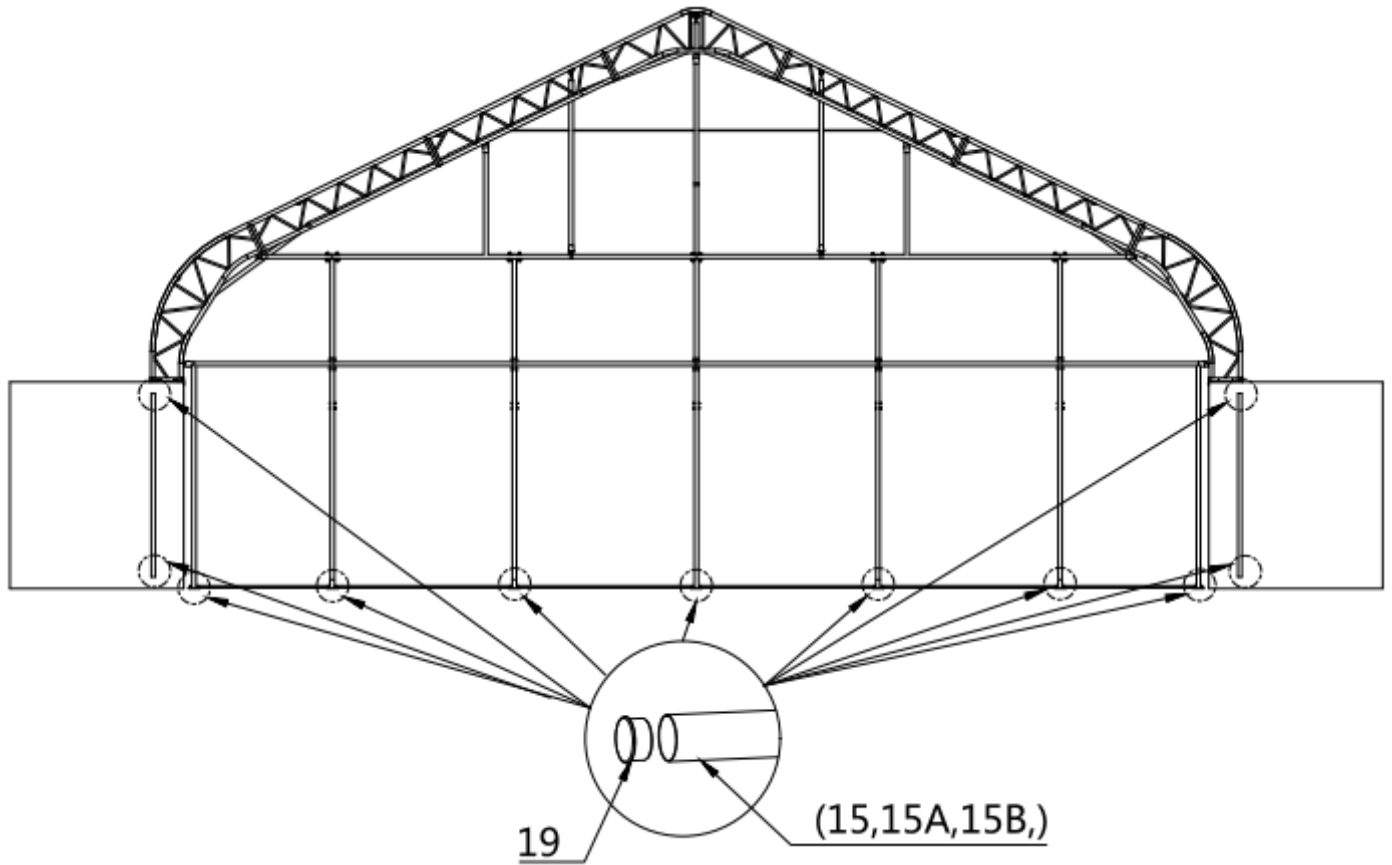

PARTS CODE	PART	QTY
19		16

**STEP 15 : INSTALL FRONT CLOTH.**

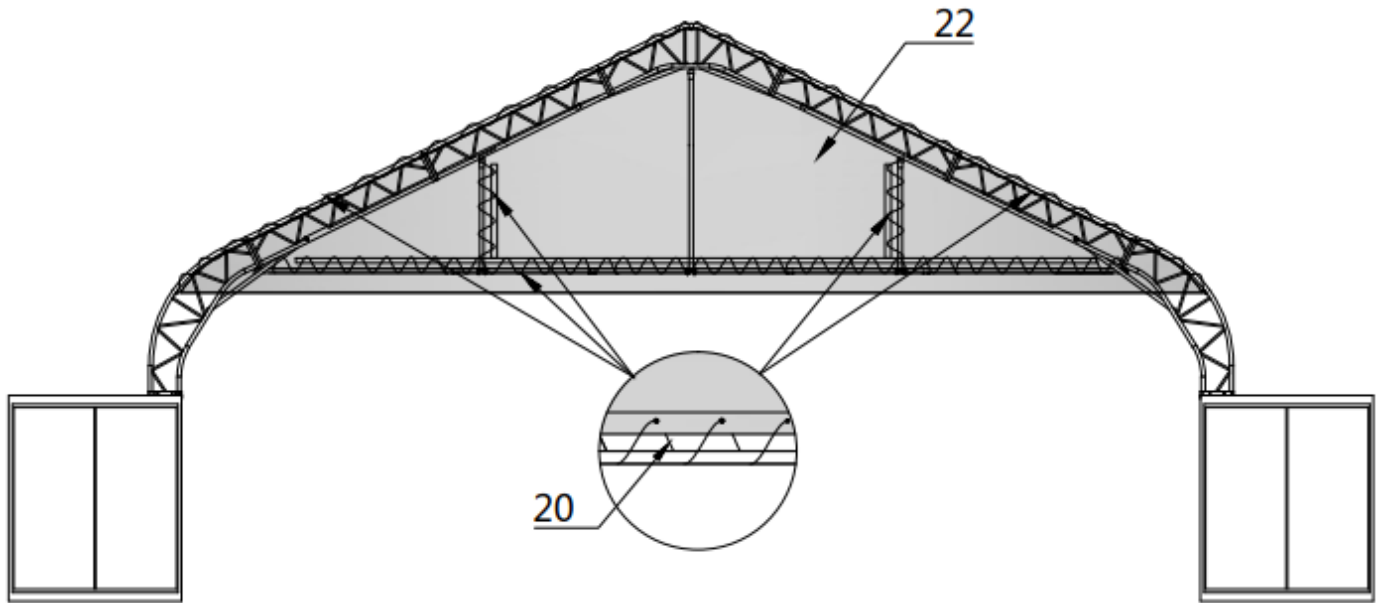

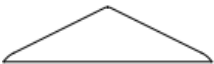
PARTS CODE	PART	QTY
20		1
22		1

**STEP16 : INSTALL THE REAR CLOTH.**

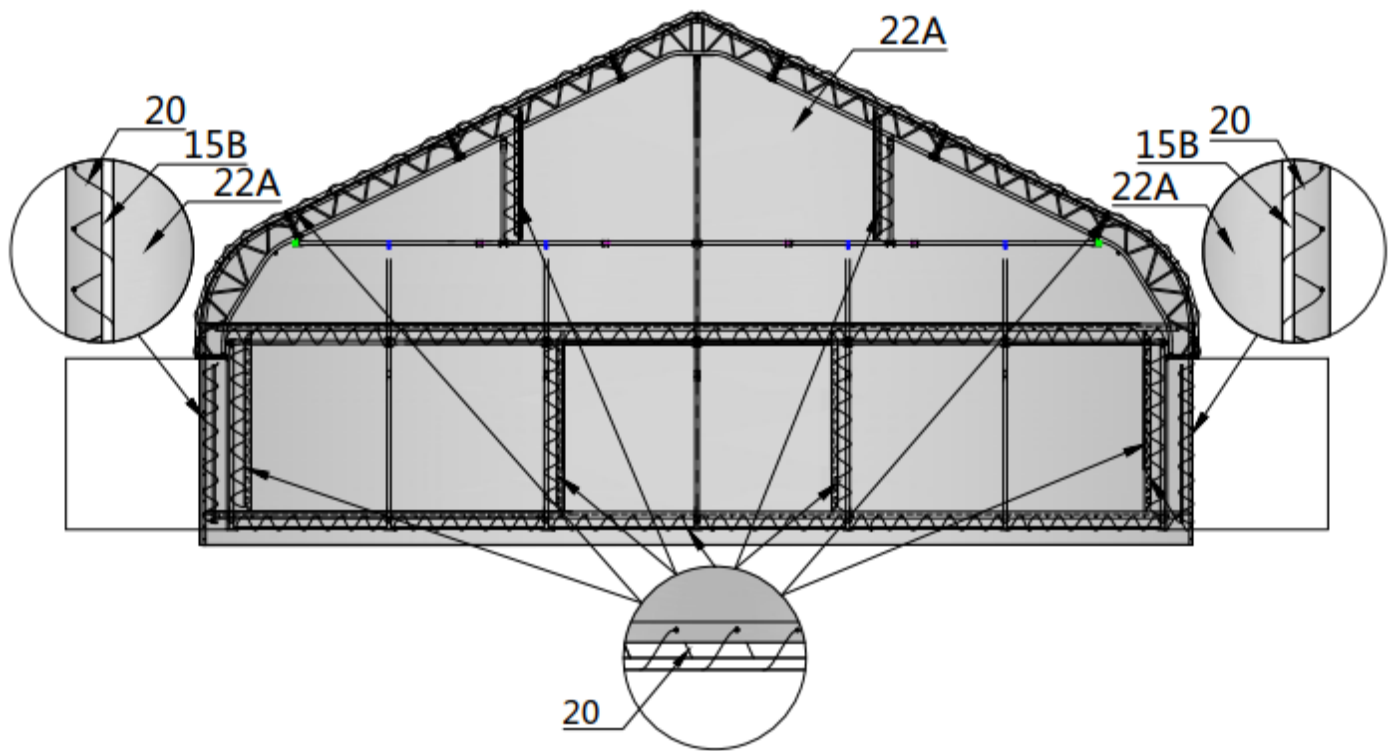

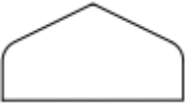
PARTS CODE	PART	QTY
19		1
22A		1



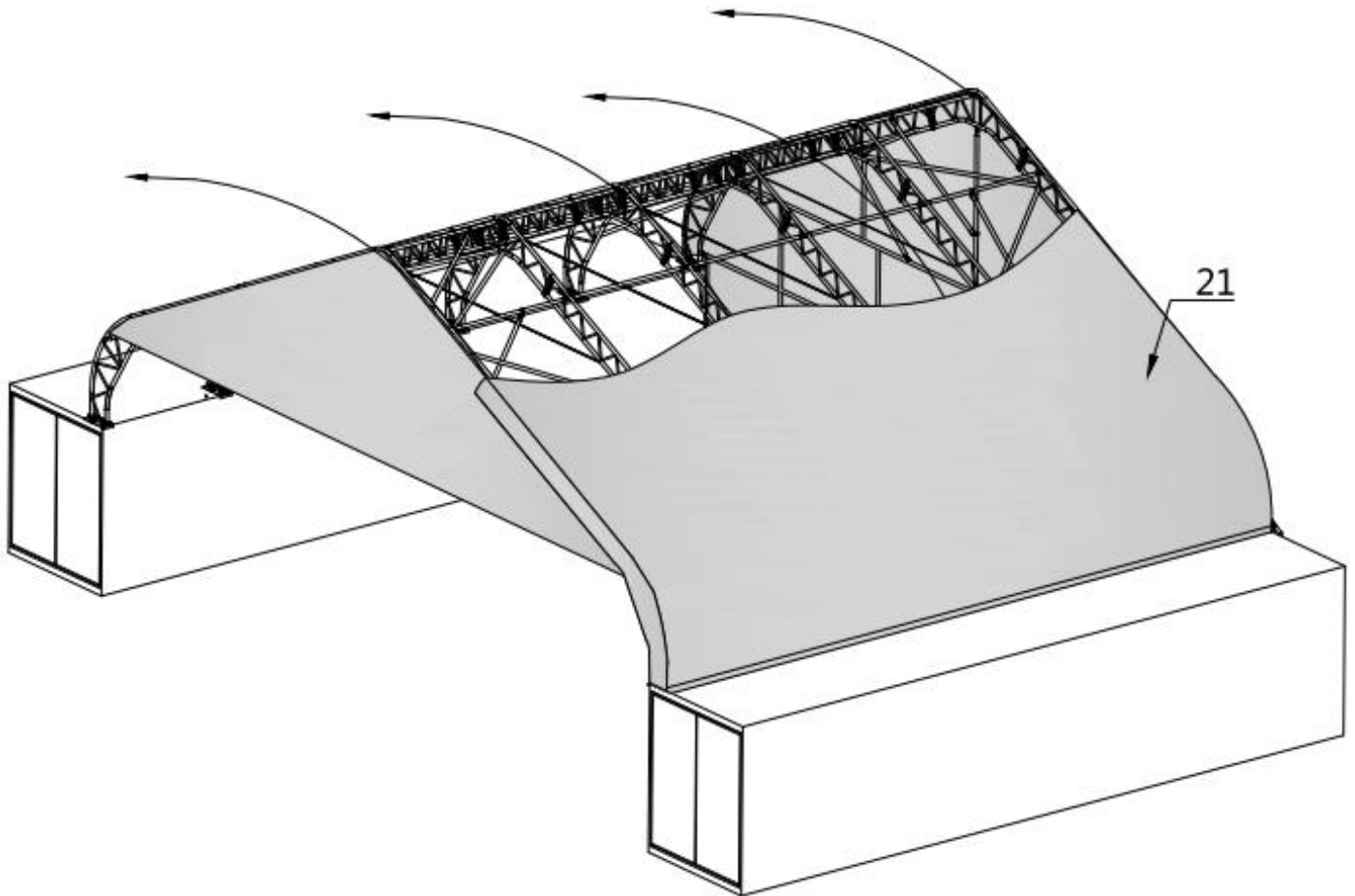

**STEP 17 : INSTALL THE TOP CLOTH.**

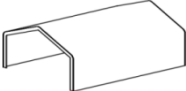

PARTS CODE	PART	QTY
21		1

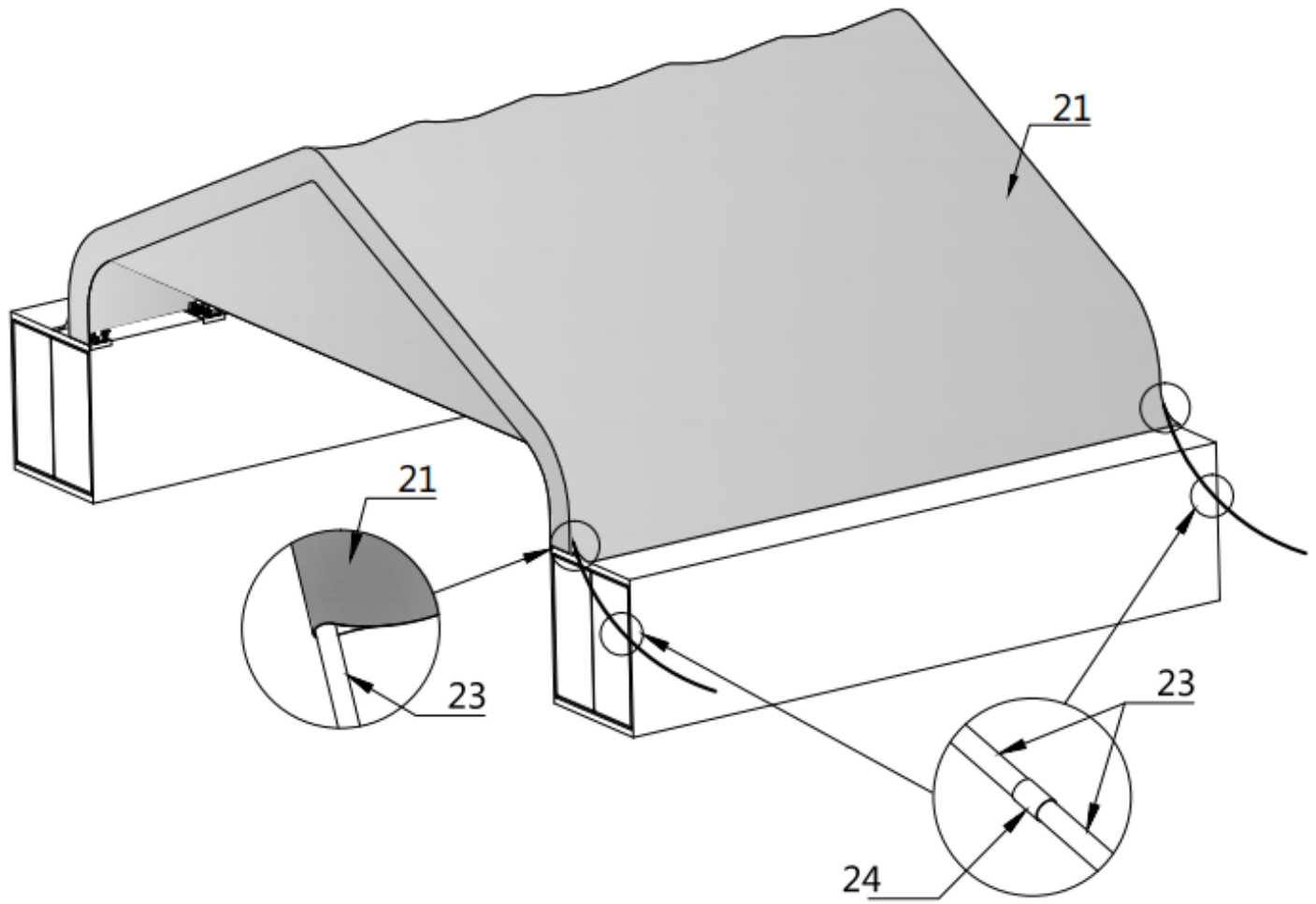

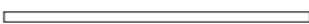
**STEP 18 : INSTALL THE HOSE AT BOTH ENDS OF THE TOP CLOTH.**



PARTS CODE	PART	QTY
23		10
24		8

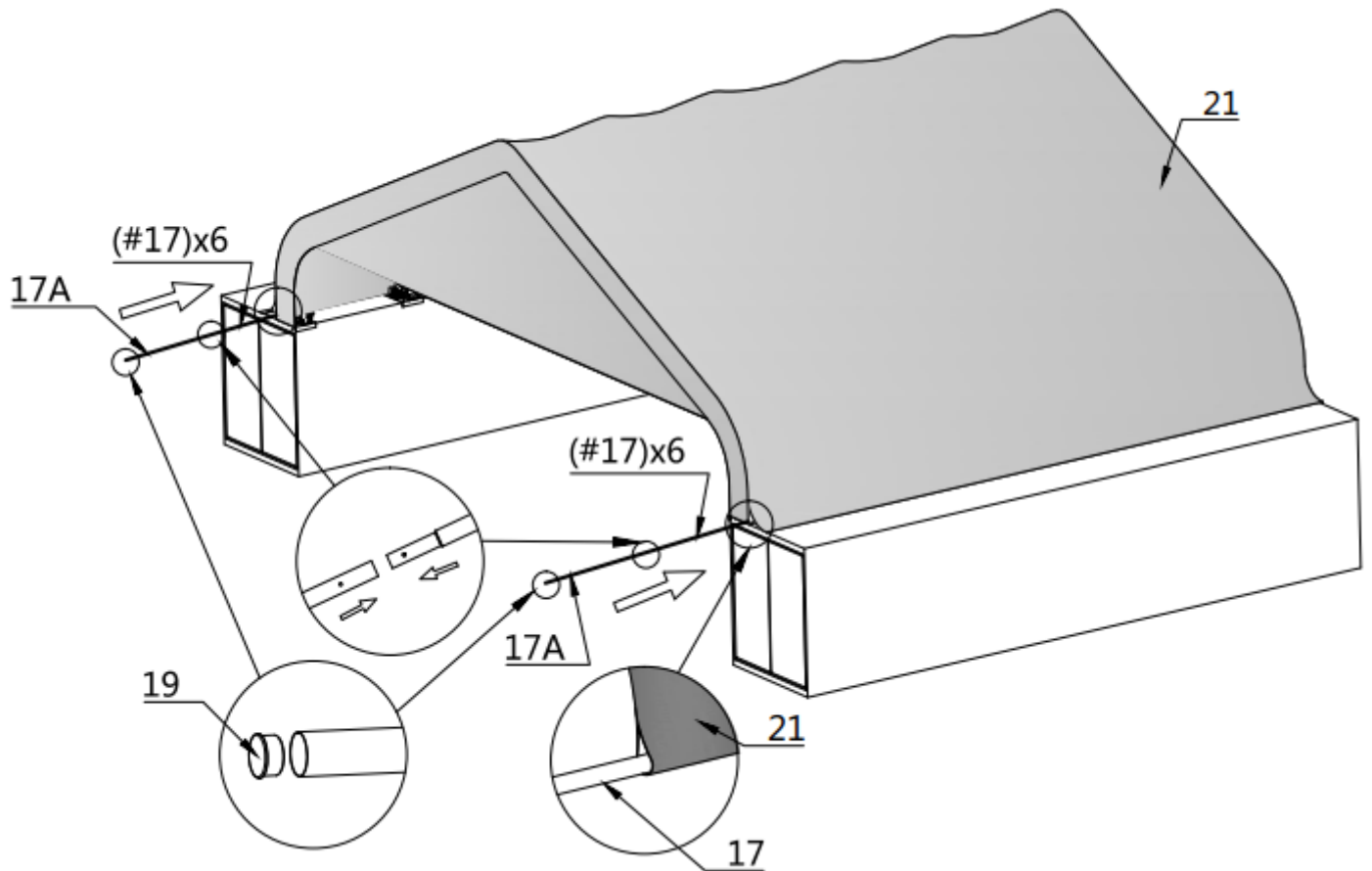

**STEP 19 : INSTALL METAL PIPES ON BOTH SIDES.**



PARTS CODE	PART	QTY
17		12
17A		2
19		4

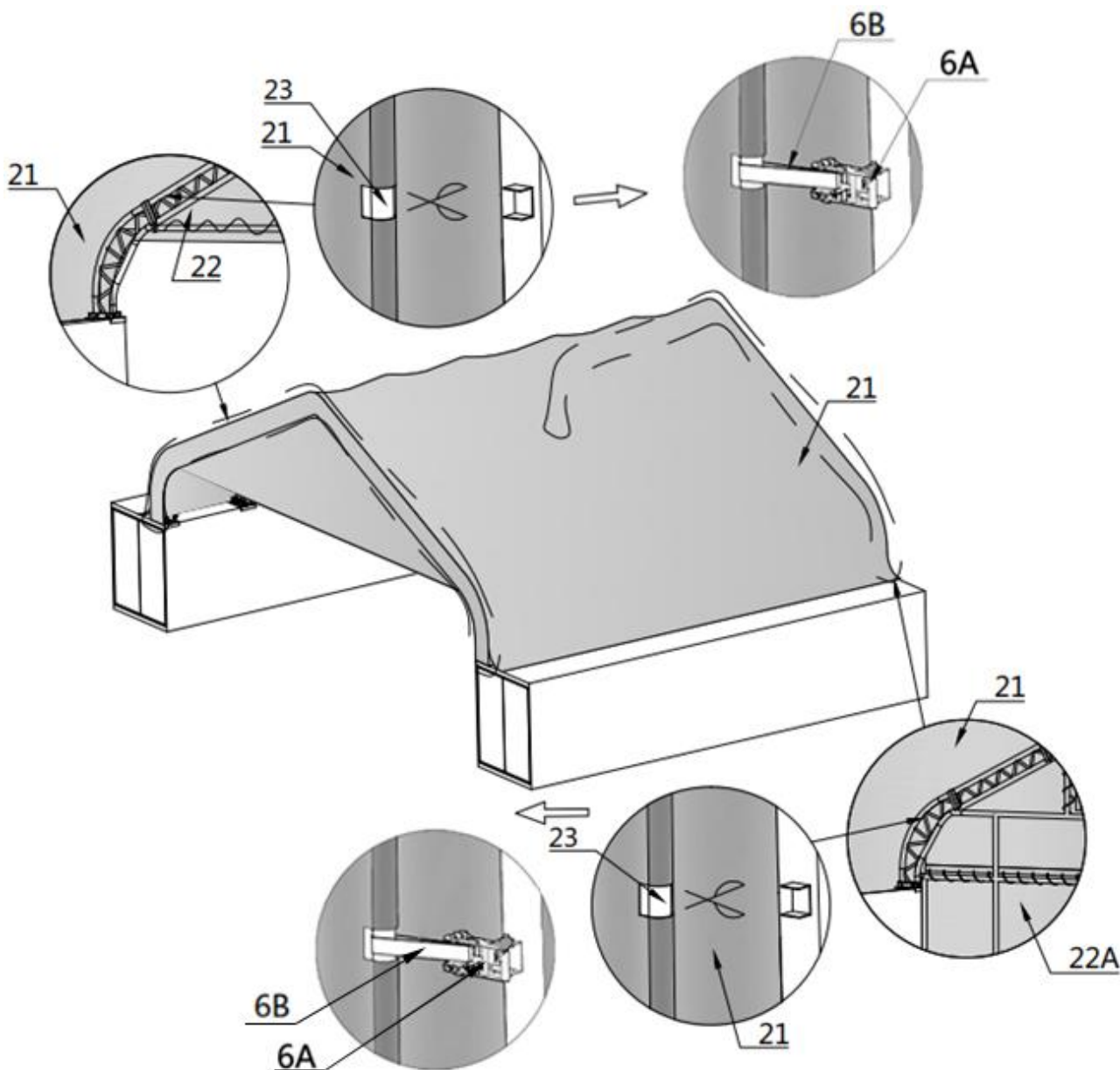

**STEP 20 : TENSION BOTH ENDS OF THE TOP CLOTH WITH THE TENSIONING DEVICE.**

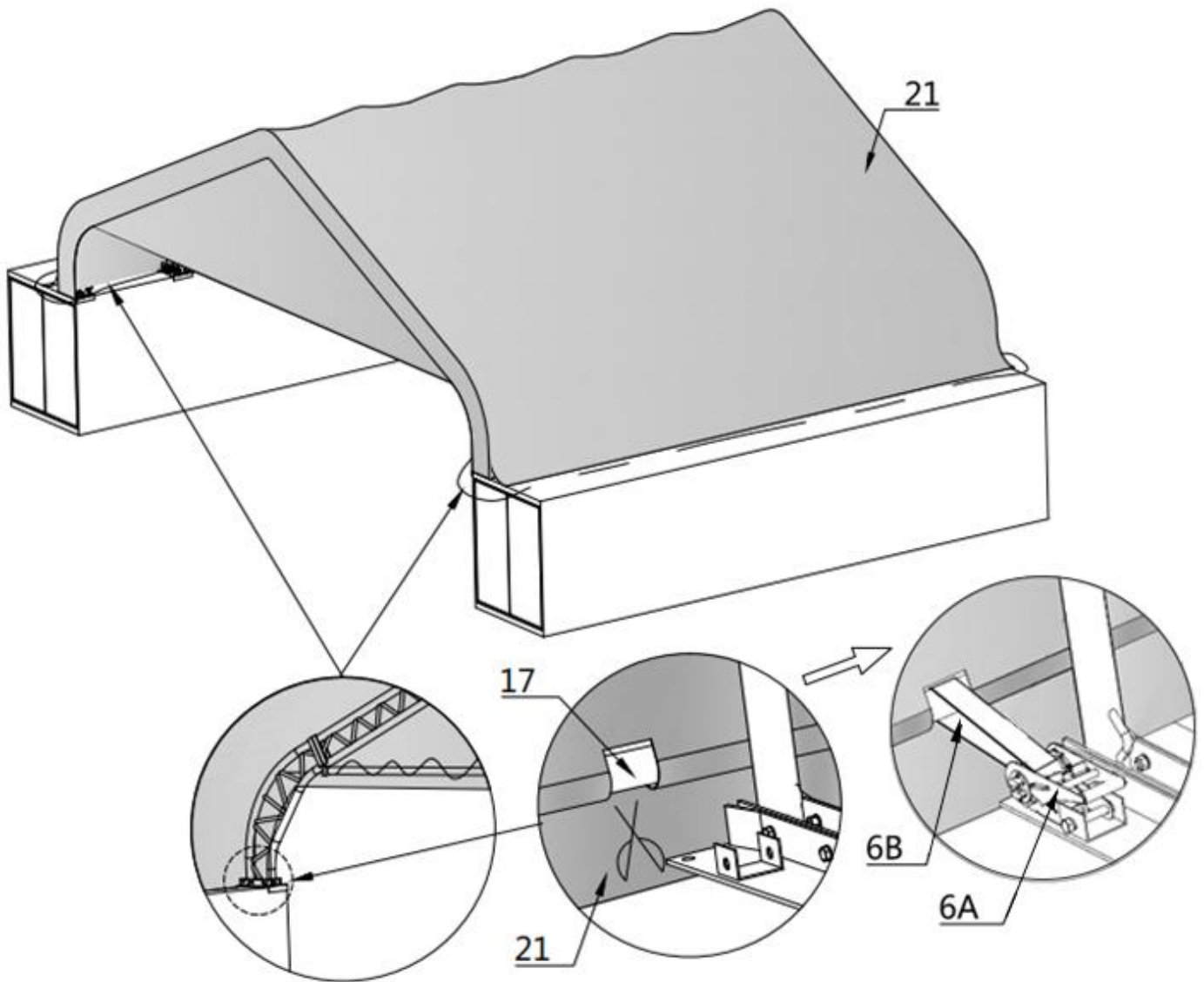

PARTS CODE	PART	QTY
6A		32
6B		32

**STEP 21 : TENSION BOTH SIDES OF THE TOP CLOTH WITH THE TENSION DEVICE.**







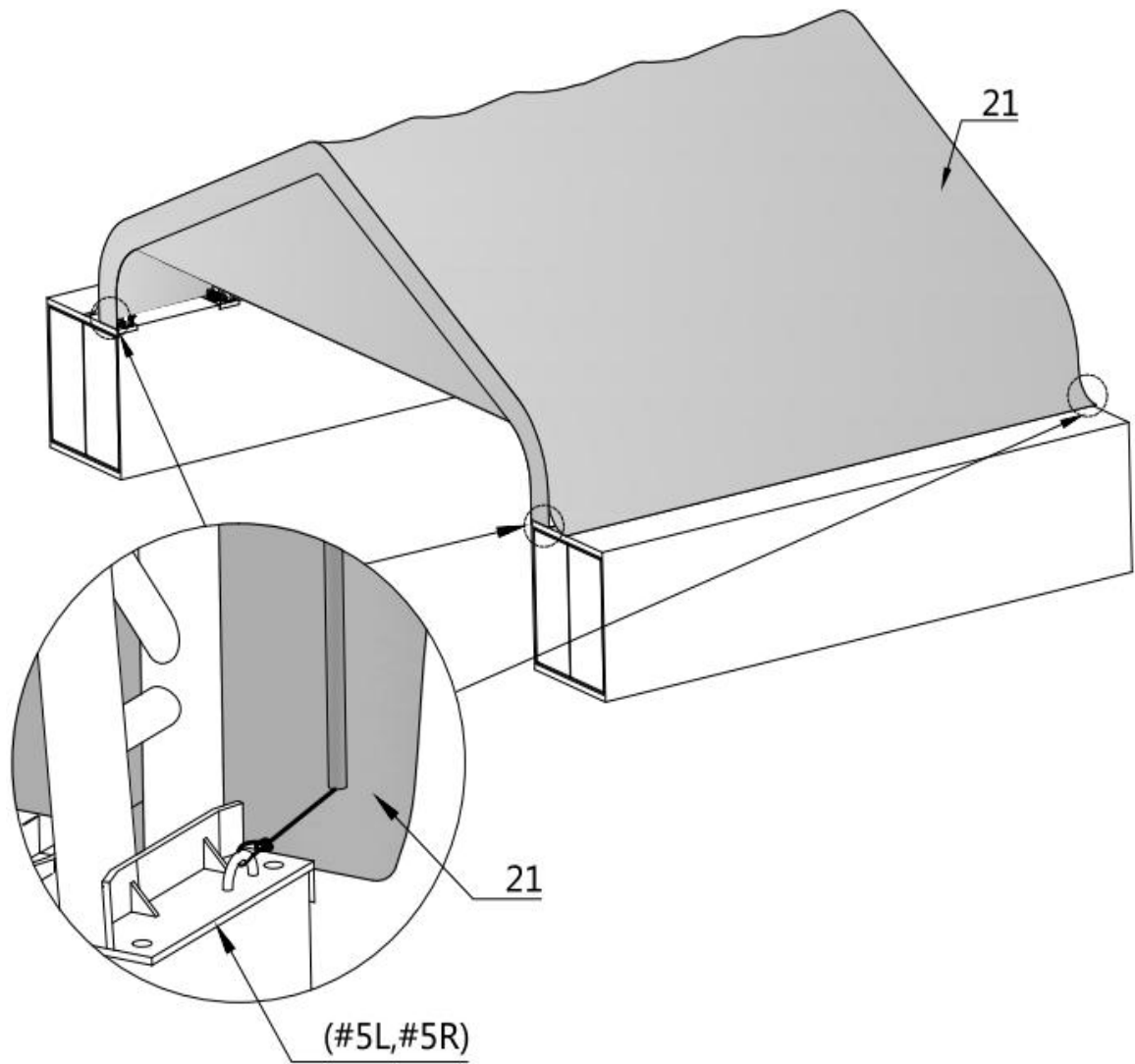



PARTS CODE	PART	QTY
6A		12
6B		12





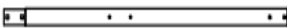

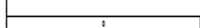
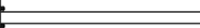



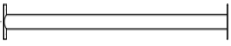





**STEP 22 : TIE THE ROPE.**





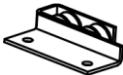





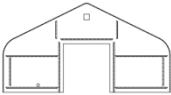

**MAIN SPECIFICATIONS :**

- Overall assembled size : W15.24 x H7.8 (m) / W50x H25.6 (ft)
- Width : 15.24 m / 50ft
- Height : 7.8 m / 25.6ft
- Front door : 4.6x3.85 (m) / 15.1x12.6 (ft)

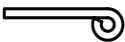
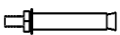
TMG-DT50FW8 PART LIST				
NO.	PICTURE	DESCRIPTION	LENGTH	QTY
7		Baseplate	W150xL200mm	2
7A		Baseplate	W150xL200mm	2
7B		Baseplate of front door frame	W150xL200mm	2
8A		Side vertical tube	L2693mm	1
8B		Lower vertical tube	L2307mm	1
8C		Lower vertical tube	L2307mm	1
8D		Side vertical tube	L2693mm	1
9		Middle vertical tube	L1990mm	2
9B		Side door left tube	L2027mm	1
9C		Side door right tube	L2027mm	1
9D		Side door	W925xL2005mm	1
10B		Transverse tube	L2461mm	2

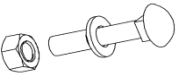
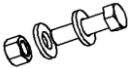
10C		Middle transverse tube	L2362mm	2
10D		Side door upper tube	L2369mm	1
10L		Front vertical door rail (left side lower part)	L2625mm	1
10R		Front vertical door rail (right side lower part)	L2625mm	1
11L		Front vertical door rail (left side upper part)	L1720mm	1
11R		Front vertical door rail (right side upper part)	L1720mm	1
12A		Front roll up door dropping tubes (to connect #12B)	L2356mm	7
12B		Front roll up door dropping tubes (to connect #12A)	L2359mm	7
14A		Front door hand winch crossing tube	L2362mm	1
15		Bottom tension bar	L2310mm	3
15D		Bottom tension bar	L640mm	2
18		Tube clamps	φ 58	6
18A		Front vertical door rail end plate (floatable to keep door rail straight)	L220mm	2
18B		Right pulley system for front door	L150mm	1
18C		Left pulley system for front door	L150mm	1
18D		Front vertical door rail connection plate	L240mm	2
19		Tube end water plug	φ 32	10

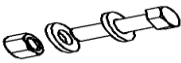

20		Braided rope	100m	1
22		Front truss fabric cover panel	W15.1xL8m	1
22B		Front roll up door cover panel	W4550xL4520mm	1
23A		Roll up door hand winch	(1200 lb)	1
23B		Wire rope for front door hand winch	15m	1
24A		Front fabric tarp secure pin	L200m	1
25		Expansion bolts	φ 16x150mm	16
25A		Pressing plate	L2000mm	6
25B		Pressing plate	L1000mm	1
27		Self locking bolt and nuts	M8x70mm	12
29		Hex bolt and nuts	M10x80mm	32
30		Hex bolt and nuts	M10x50mm	8
31		Hex bolt and nuts	M10x100mm	4
32		Tapping screw	#12x25mm	62

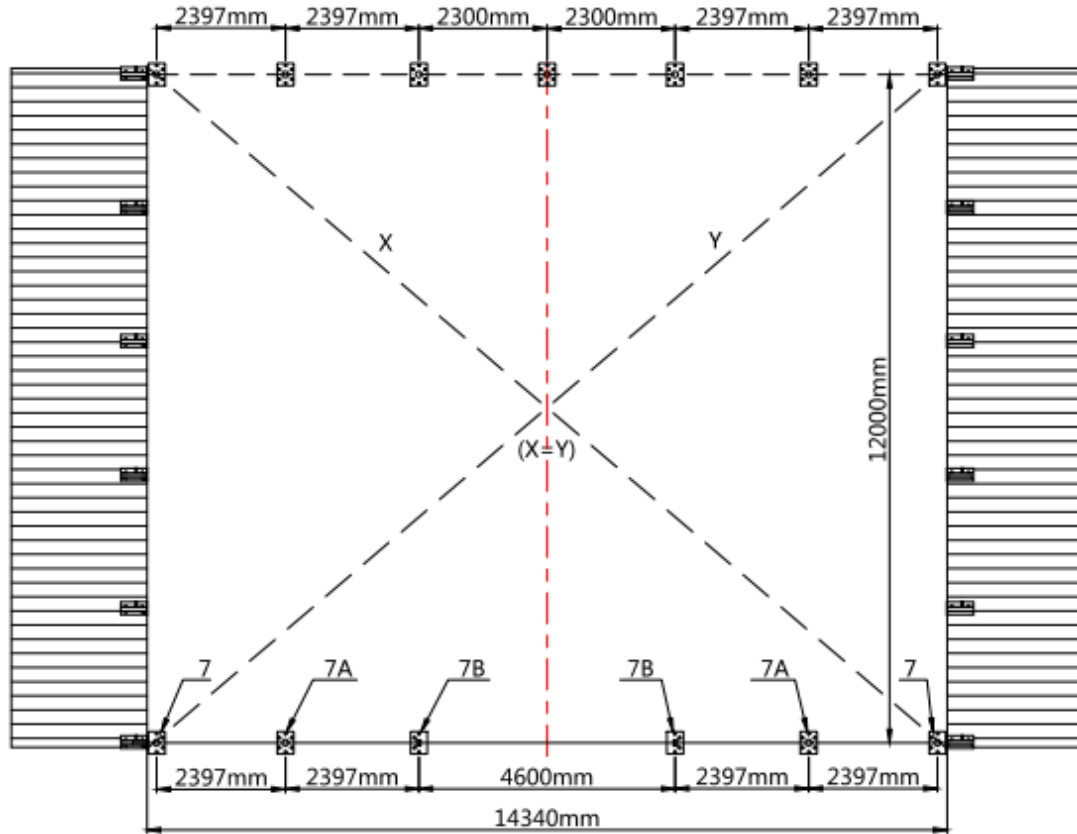

**STEP 1 : REVIEW THE WHOLE STRUCTURE AND CHOOSE THE PROPER INSTALLATION SITE.**

- Place the containers making sure they are parallel and the correct width apart the diagonal X and Y must be equal. Baseplates must be bolted firmly with expansion bolts, It is concrete expansion bolt.

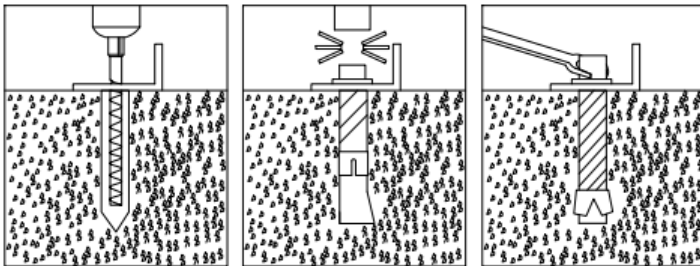

- Installation diagram of expansion bolt.

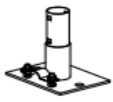



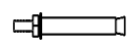



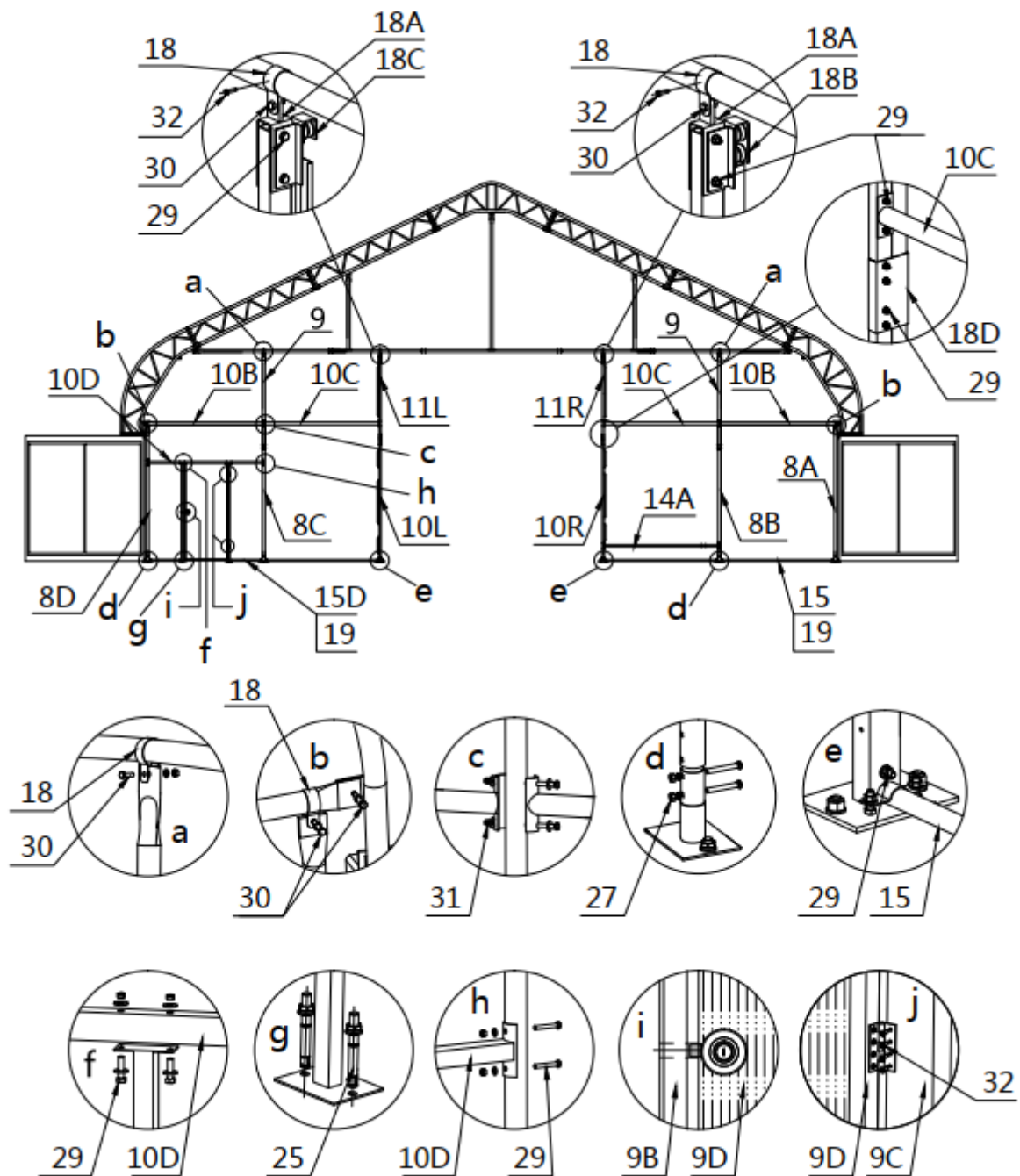



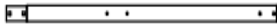

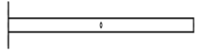
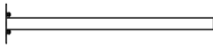

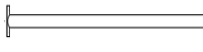







NO.	PART	QTY
7		2
7A		2

NO.	PART	QTY
7B		2
25		12

STEP 2 : FRONT TRUSS TO COMPLETE.



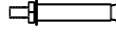
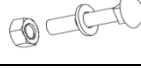
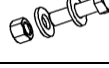
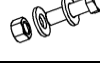
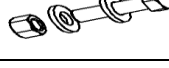

NO.	PART	QTY
8A		1
8B		1
8C		1
8D		1
9		2
9B		1
9C		1
9D		1
10B		2
10C		2
10D		1
10L		1
10R		1
11L		1
11R		1

NO.	PART	QTY
14A		1
15		3
15D		2
18		6
18A		2
18B		1
18C		1
18D		2
19		10
25		4
27		12
29		30
30		8
31		4
32		10

**STEP 3 : INSTALL FRONT COVER PANEL.**

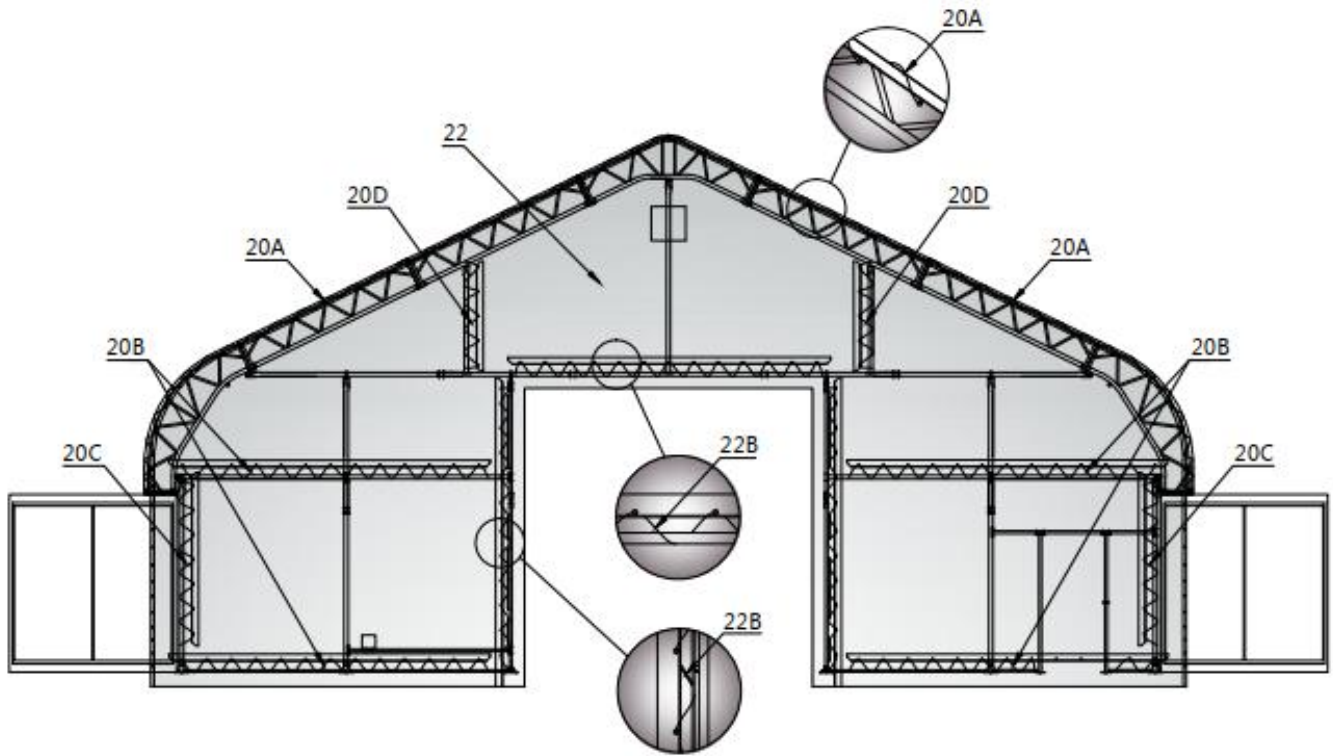
- Lift up (#22) cover panel, starting from the center point of the frame (highest ridge point) use ropes (#20) through the grommets to tie the panel to the truss firmly. All grommets need to be tied to the frame as shown.





NO.	PART	QTY
22		1

ROPE SHEAR SIZE		
20		Qty
A	15m	2
B	7m	7
C	4m	2
D	3m	2

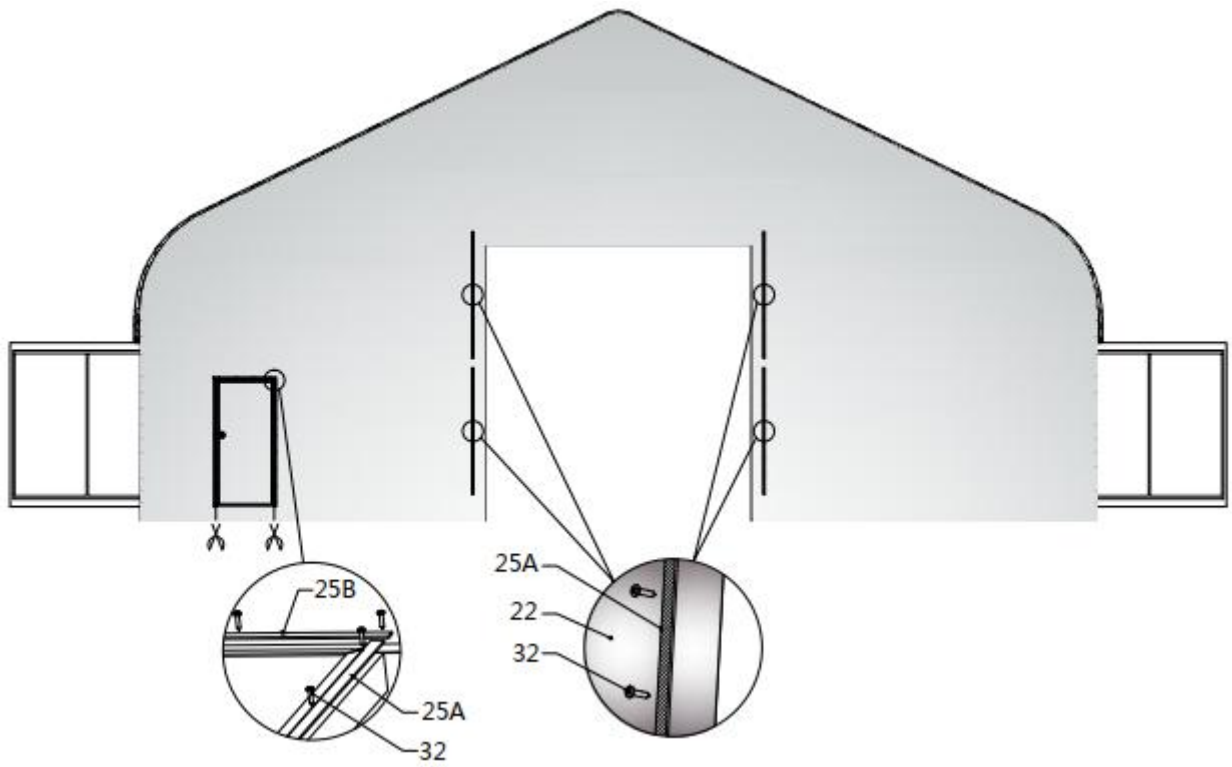
- Install the front door metal strip.





NO.	PART	QTY
25A		6
25B		1

NO.	PART	QTY
32		52

**STEP 4 : INSTALL MECHANICAL ROLL UP DOORS.**

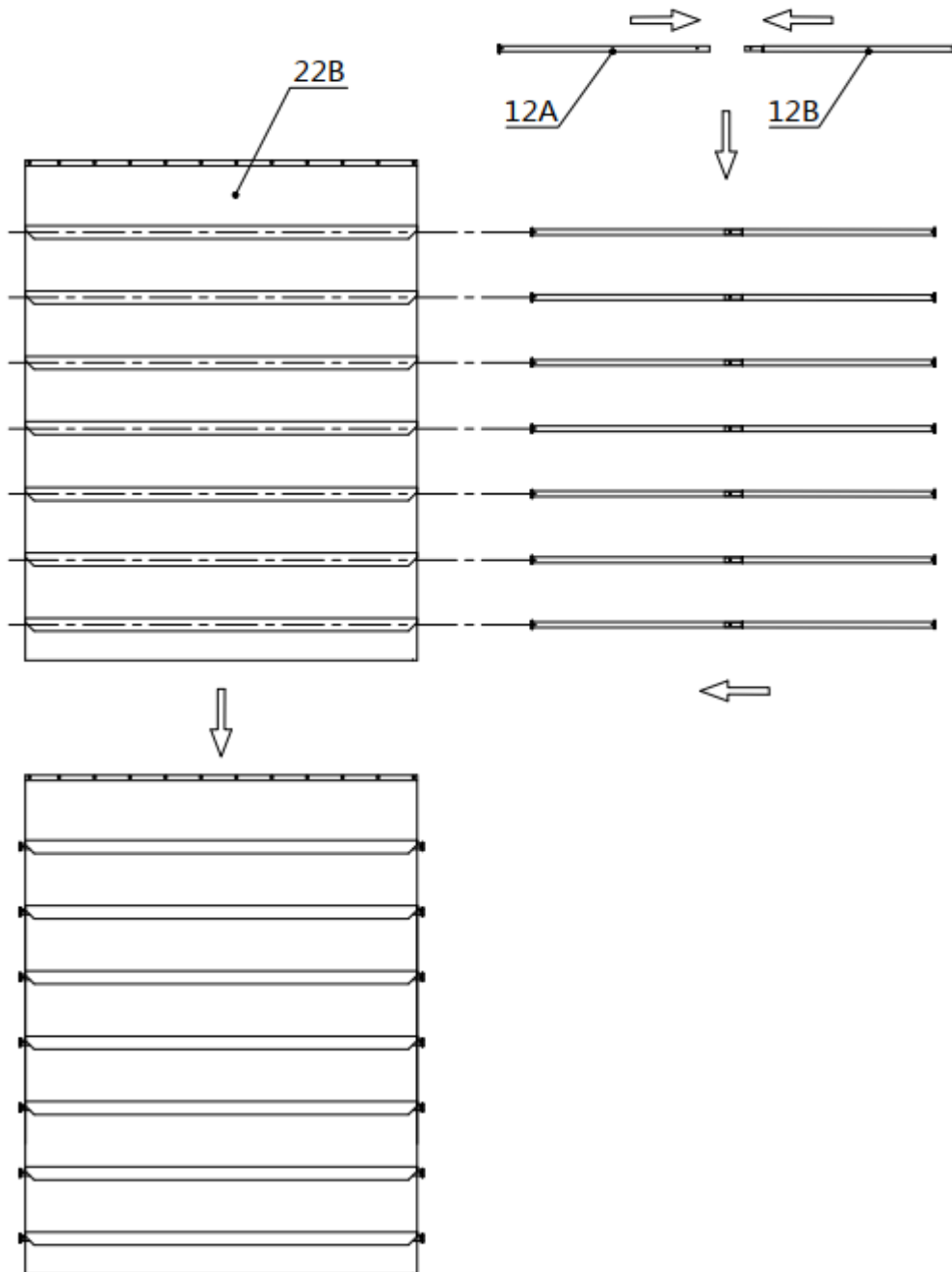
- Door curtain installation.



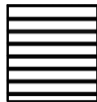

NO.	PART	QTY
12B		7
12A		7

NO.	PART	QTY
22B		1

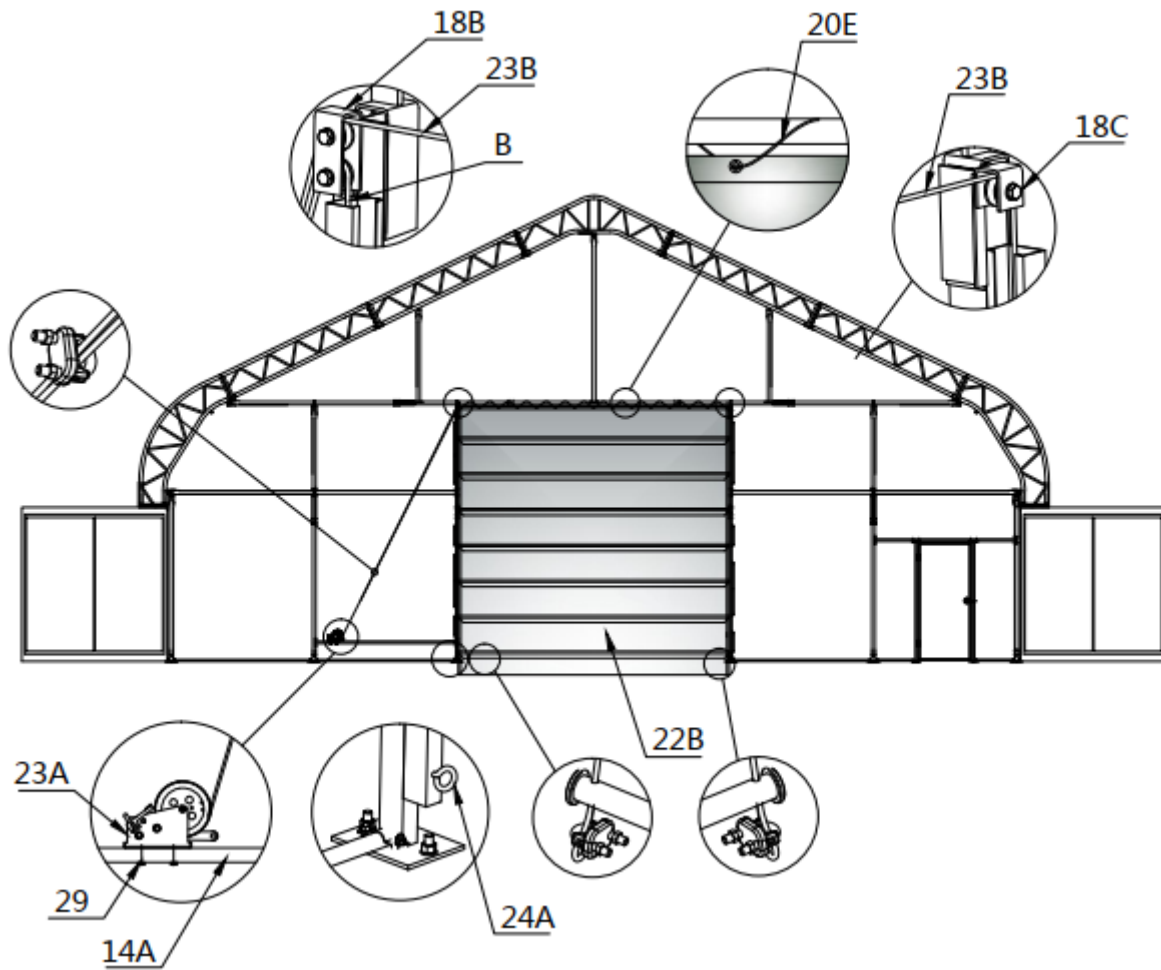
- Front door installation, please look at the door from inside.
- The hand winch (#23A) comes with a shorter cable, we call it cable (#B).

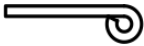
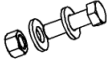

NO.	PART	QTY
23A		1
23B		1
24A		1
29		2

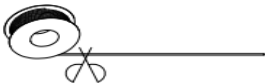
ROPE SHEAR SIZE		
20		Qty
E	7m	1



## **AFTER THE INSTALLATION**

Walk around and inspect the building periodically to make sure all components are still firmly secured and the whole building is well supported. Check all bolts and nuts as well as all connection points to make sure they are all in good position. Check the base plates, adjust the ropes and tie downs if required and clean the cover regularly.

Snow accumulating on the fabric cover must be removed as soon as possible. If snow becomes solid ice on the cover, it will increase the weight on the roof and collapses the building or reduce the life span eventually. Keep the building on a dry ground most of the time. Do not keep the fabric dirt skirt under water all the time, otherwise the fabric will deteriorate.

We strongly recommend you remove any snow from the roof immediately. Do not leave any snow load on the roof overnight. Keep 3 feet of clearance on all sides at all times. Do not allow snow to accumulate and pile up on the sides of the building. Otherwise the push from the sides toward inside will make the building collapsed at some point.