

50Ft x 150Ft Dual Truss Hoop Building

Model:TMG-DT50150-PRO



- Please read the product manual completely before assembly
- Check against the parts list to make sure all parts are received
- Wear proper safety goggles or other protective gears while in assembly

Missing parts or questions on assembly?

Please call: 1-877-761-2819 or email: cs@tmgindustrial.com

Do not return the product to dealer, they are not equipped to handle your requests

Main Specifications :

- Assembly size : W15.24 x L45.6 x H7.0 (m) / 50 x 150 x 23 (ft)
- Outside width : 15.24 m / 50ft, inside width : 14.4 m / 47.4 ft, length : 45.6 m / 150 ft
- Ridge peak height : 7.0 m / 23 ft
- Peak clearance height : 6.4 m / 21 ft
- Roll up door : 4.6 x 4.7 (m) / 15 x 15.4 (ft) (The front and rear doors are the same size).
- Shoulder wall clearance height : 2.8 m / 9 ft

It is your option to pick and call the smaller door side as front or rear, then the wider door side will be called in an opposite way.

Prior to assembly

Please go through the whole instruction manual completely. It is very important to follow your local safety regulations and industry standards during installation. Regulations may include but are not limited to:

- Safety helmets, protective eyewear, and clothing
- Safety harnesses for all elevated workers
- Proper ladder, cage, and safety operation

Check all components and parts before installation. All parts are marked with a part number, please refer to the parts list to ensure you have all parts.

Choose a day with low or no wind to install, it is hard to assemble with heavy wind. Do not make any alterations to the structure. Do not hang any weight on the frame during installation, including parts. We are not responsible for any damages or injuries caused by inappropriate installation, unauthorized modifications or extreme weather.

This building is not intended for human occupancy.





It is recommended to use heavy duty duct tapes to tape the tube connection joint spots to protect the cover from damage and worn. It will help to extend the cover life span.

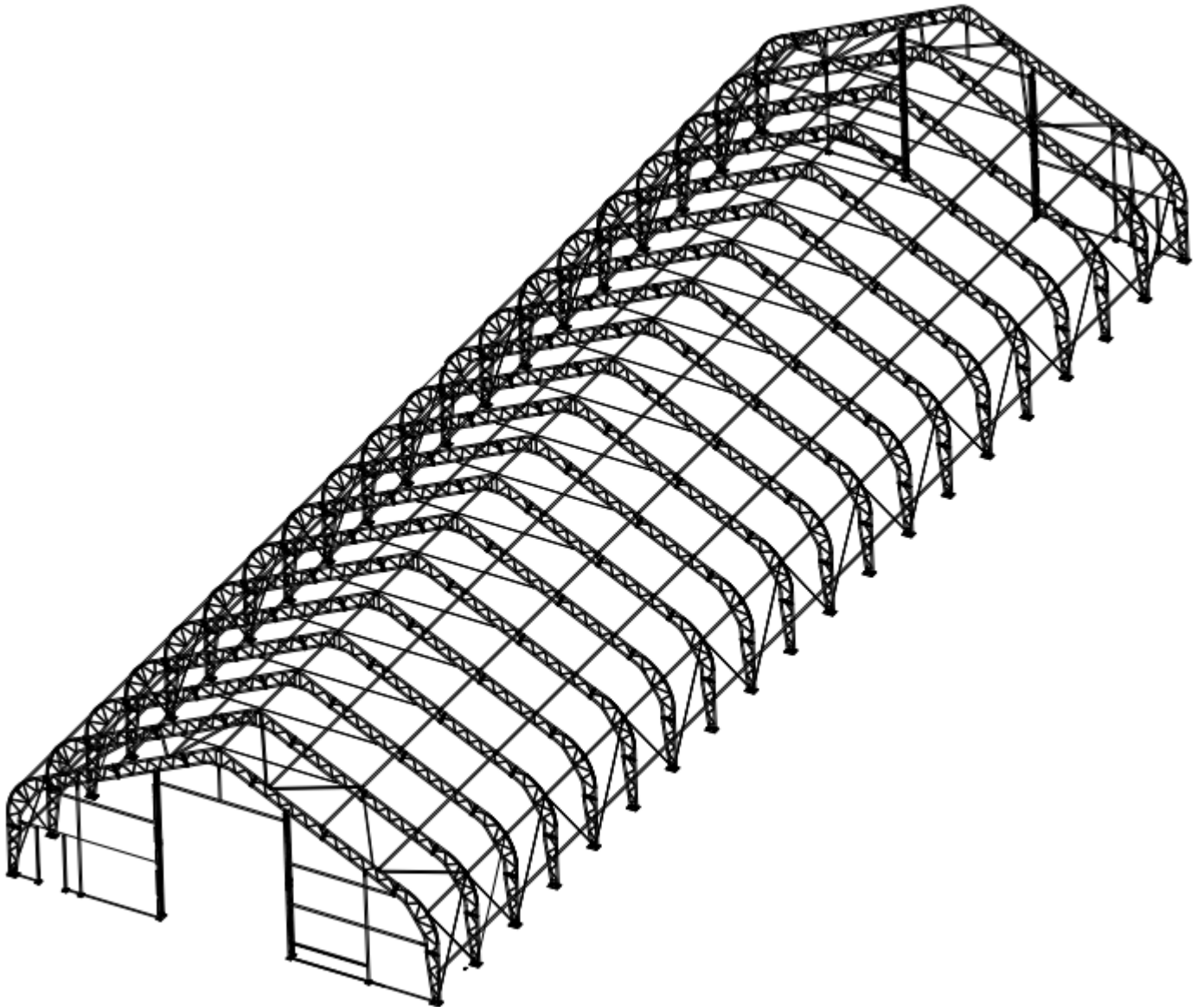





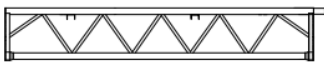
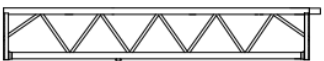
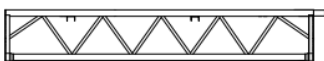
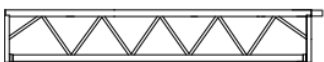
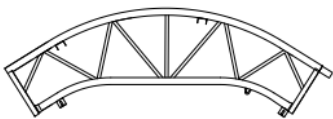
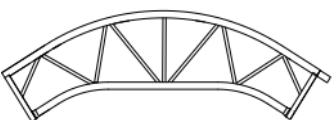
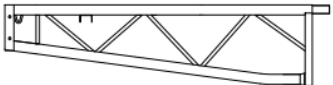
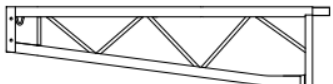

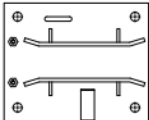

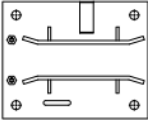
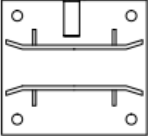
Check the parts list below to make sure all parts are received prior to assembly.

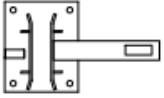

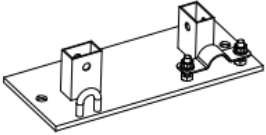
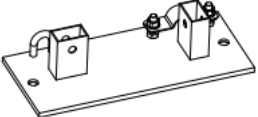
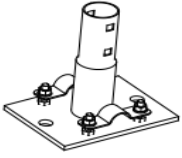







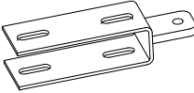





Frame structure diagram.

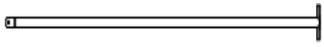

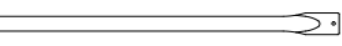





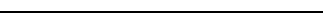











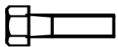

TMG-DT50150-PRO Part List

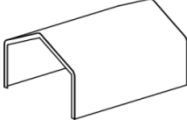
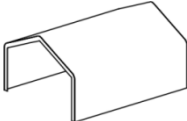
Parts Code	Graphical	Quantity	BOX
1A		2	F
1		18	B
2A		4	G
2		36	F
3A		4	C
3		36	C
4A		4	E
4		36	D/E
5A		4	D
5		36	A/G
5B		209	A
5C		16	C
5L		2	B

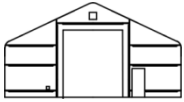
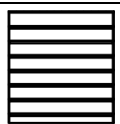
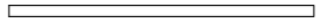
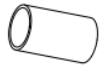
5R		2	B
6		34	B
6A		116	B
6M		2	B
6B		78	B
6C		6	B
7L		2	B
7R		2	B
7A		4	B
8		2	A
8A		2	A
8B		2	E
8C		2	A
8D		12	A

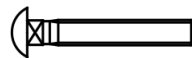
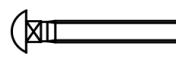
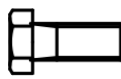
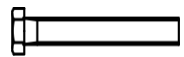
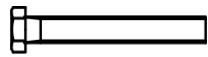
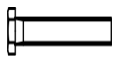
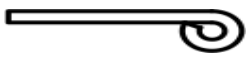
9B		8	B
9C		4	B
9L		2	A
9R		2	A
10L		2	A
10R		2	A
10A		2	A
10B		4	A
10		2	A
11		2	A
12		8	A
12A		2	A
13		2	D
13A		2	D
13B		2	A
14		2	D
15		4	D
15A		2	D
15B		2	D

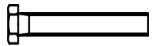

15C		2	D
16		14	D
16A		14	D
16B		22	B
16C		42	B
17		46	D
17A		2	D
17B		2	D
18		28	B
19		26	B
20		2	B
21		2	B
22		36	B
22A	 (M10x30mm)	36	B
23		7	B
24		1	G
24A		1	G

25		2	B
25A		2	B
26		24	B
26A		20	B
27	 (180m)	2	B
28	 (M10x80mm)	220	B
29	 (M8x70mm)	16	B
30	 (M12x30mm)	800	B
31	 (M10x90mm)	92	B
31A	 (M10x100mm)	8	B
32	 (M10x50mm)	34	B
33		4	B
34	 (φ 16x150)	184	B
35		24	B
36	 (M10x60mm)	12	B
37	 (#12x25mm)	104	B
38		36	B

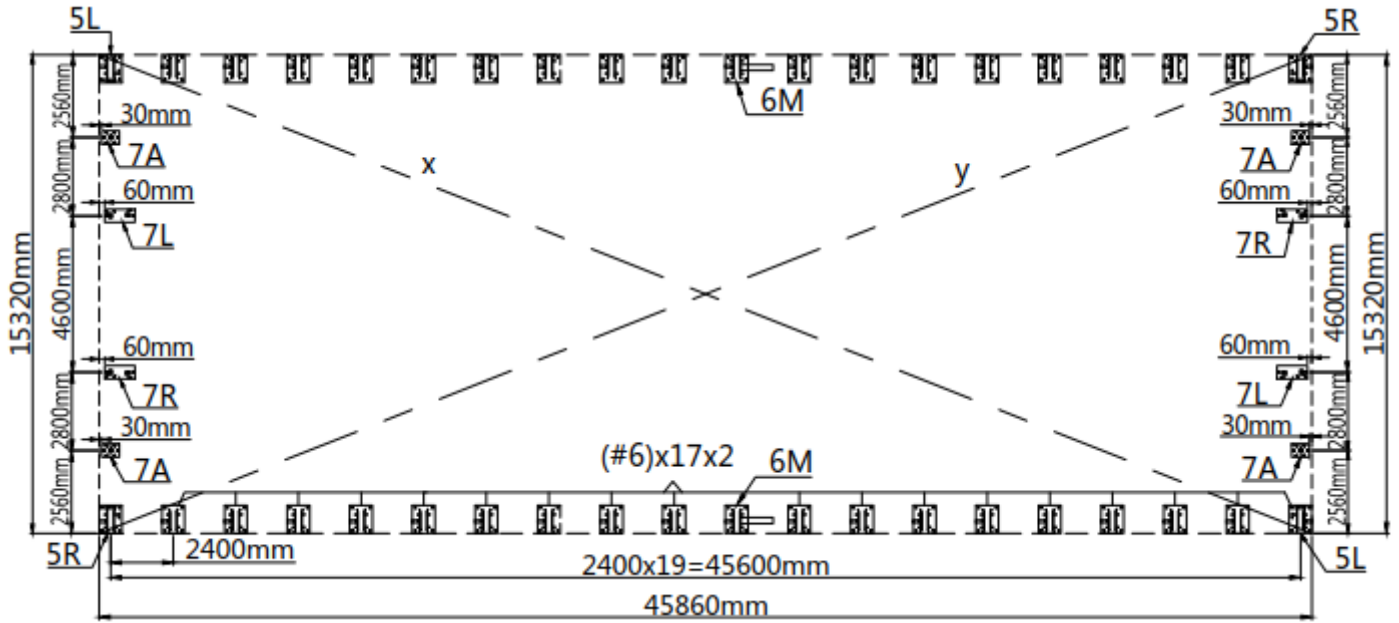
Step 1 : Baseplate positioning and installation.

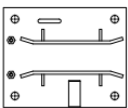
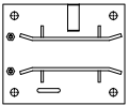
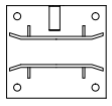
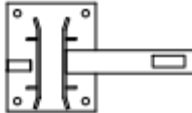

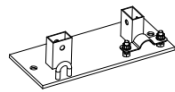
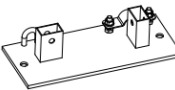
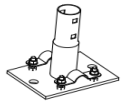

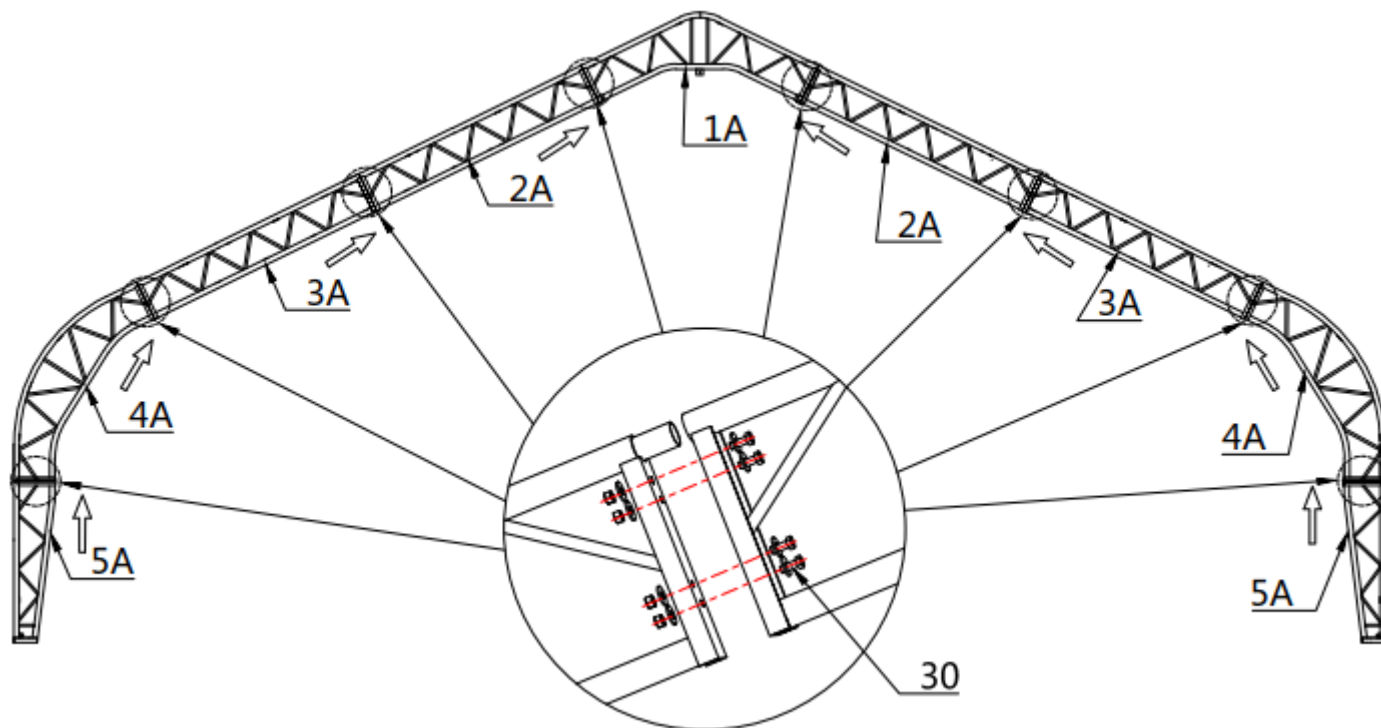

NO.	PART	Qty
5L		2
5R		2
6		34
6M		2

NO.	PART	Qty
7L		2
7R		2
7A		4
34		176

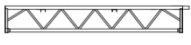
Step 2 : Installation of front and rear 2 group trusses.

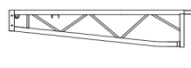

NO.	PART	Qty
1A		1x2
2A		2x2
3A		2x2
4A		2x2

NO.	PART	Qty
5A		2x2
30		32x2

Step 3 : Installation of middle 18 group truss.

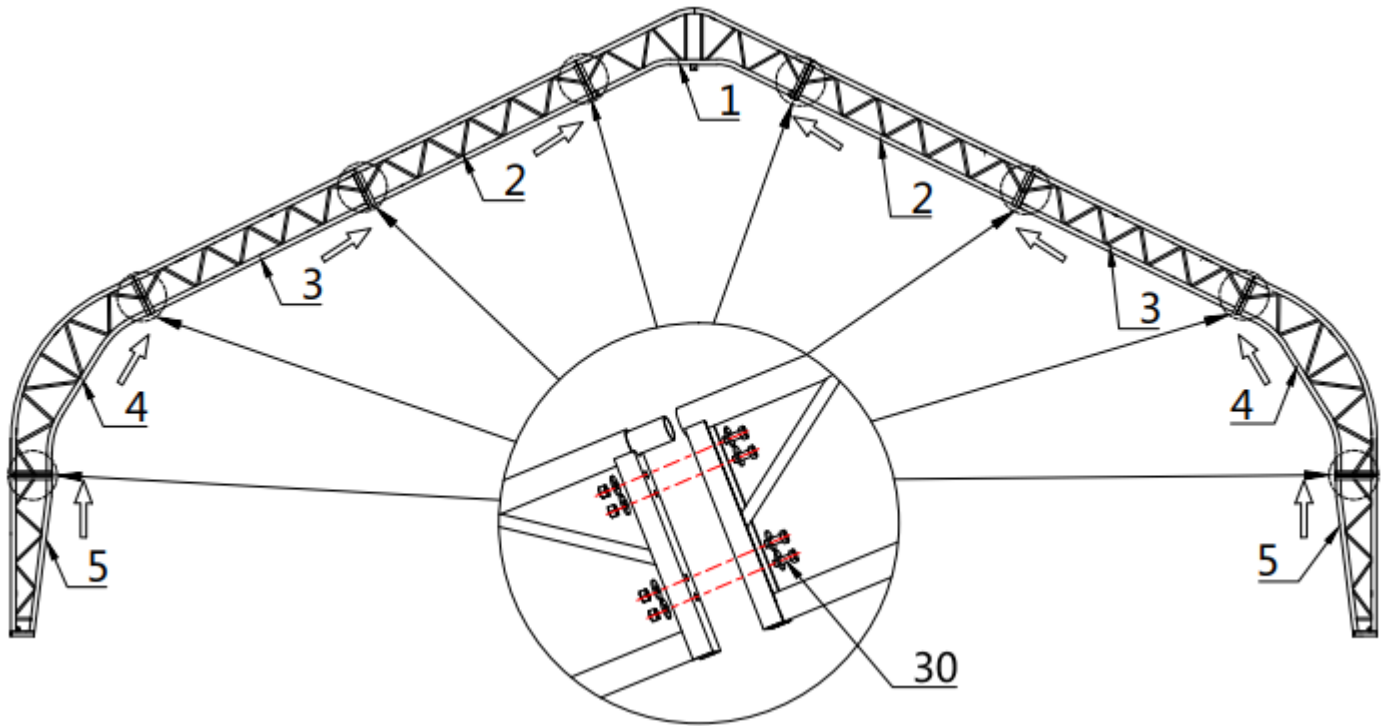

NO.	PART	Qty
1		1x18
2		2x18
3		2x18
4		2x18

NO.	PART	Qty
5		2x18
30		32x18

Step 4 : wrap (#23) around the sharp points of the joint to avoid friction between the fabric and the interface.

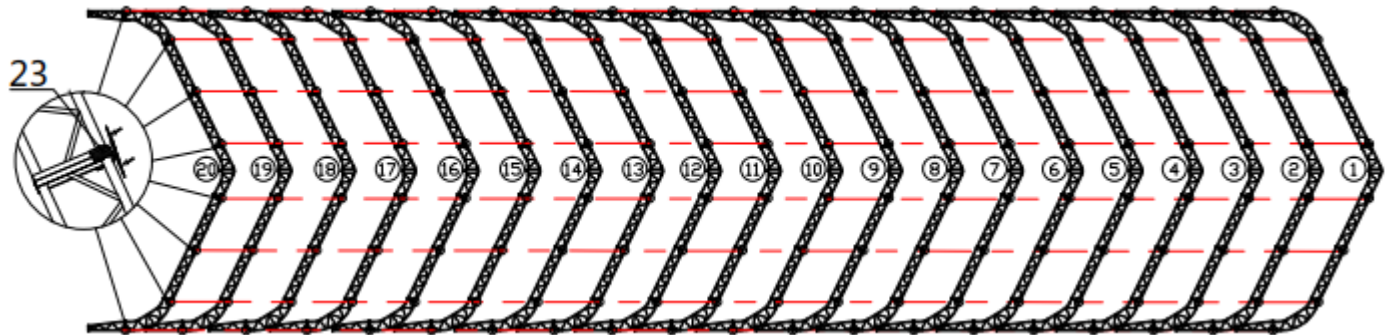

NO.	PART	Qty
23		7

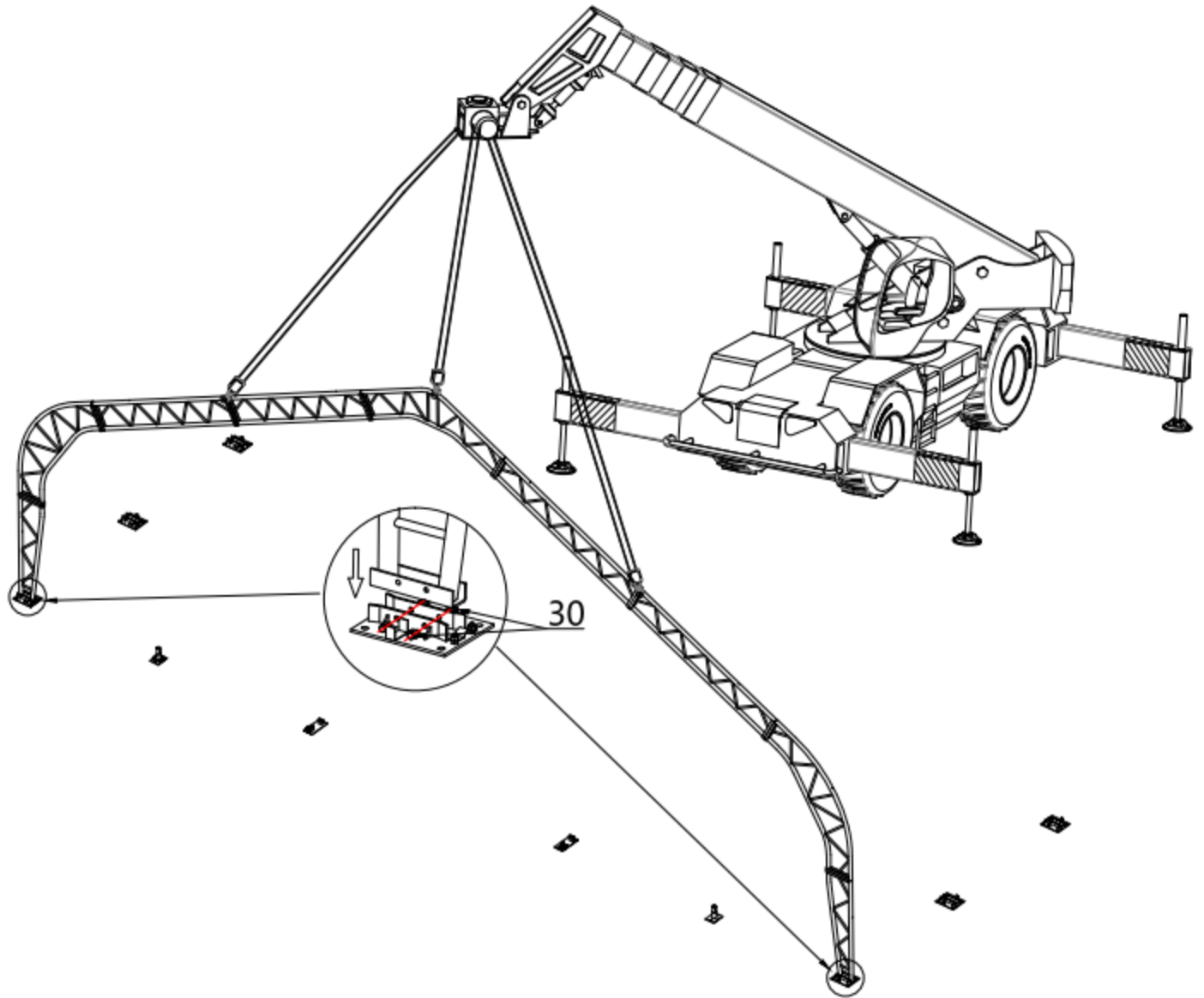

Step 5 : Put up the front truss (it is suggested to use crane for hoisting).

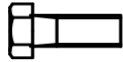

NO.	PART	Qty
30		8

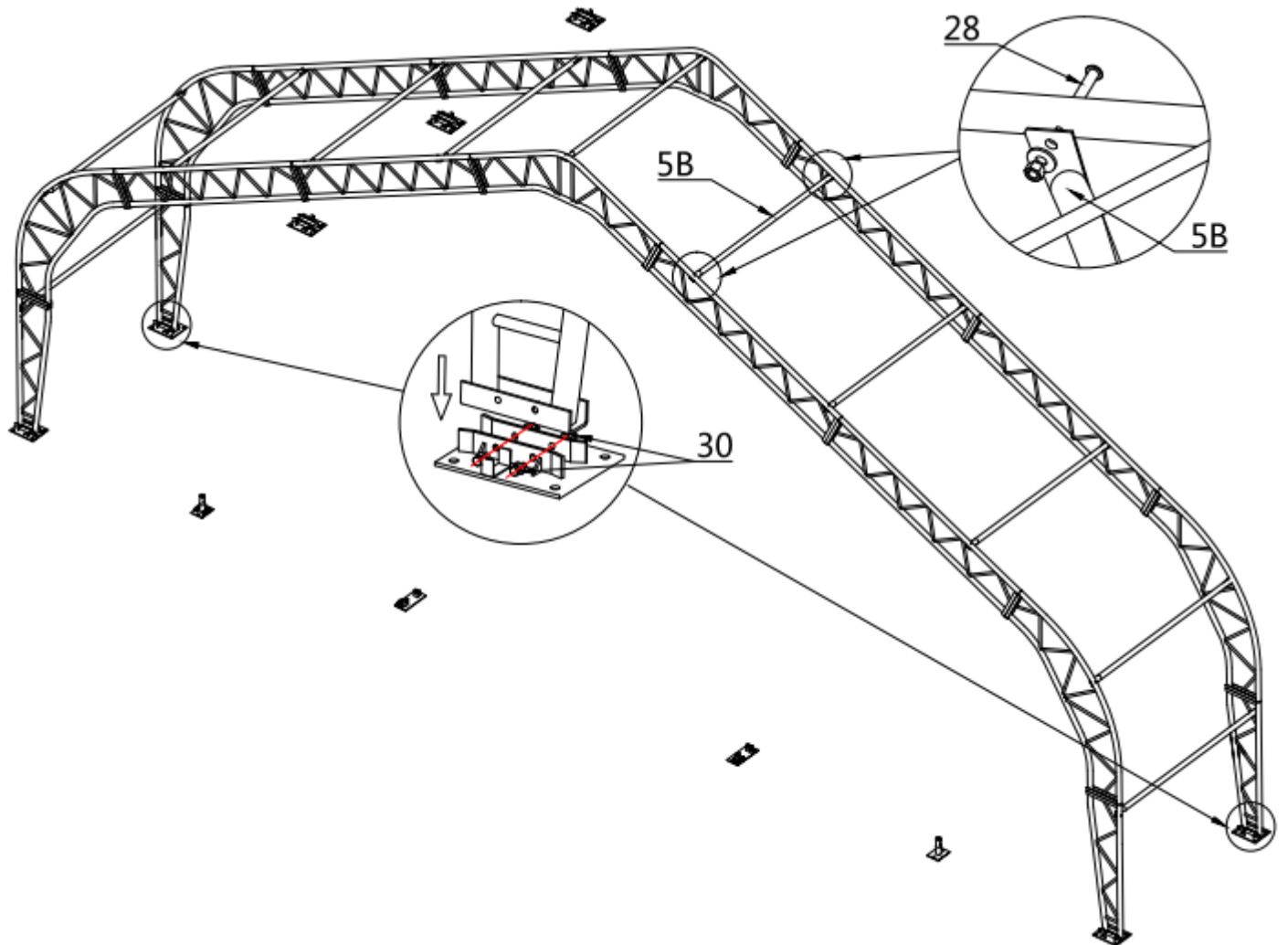
Step 6 : Put up the 2nd truss, and connect all purlins (#5B) between 1st and 2nd.

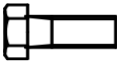

NO.	PART	Qty
5B		11
30		8
28		22

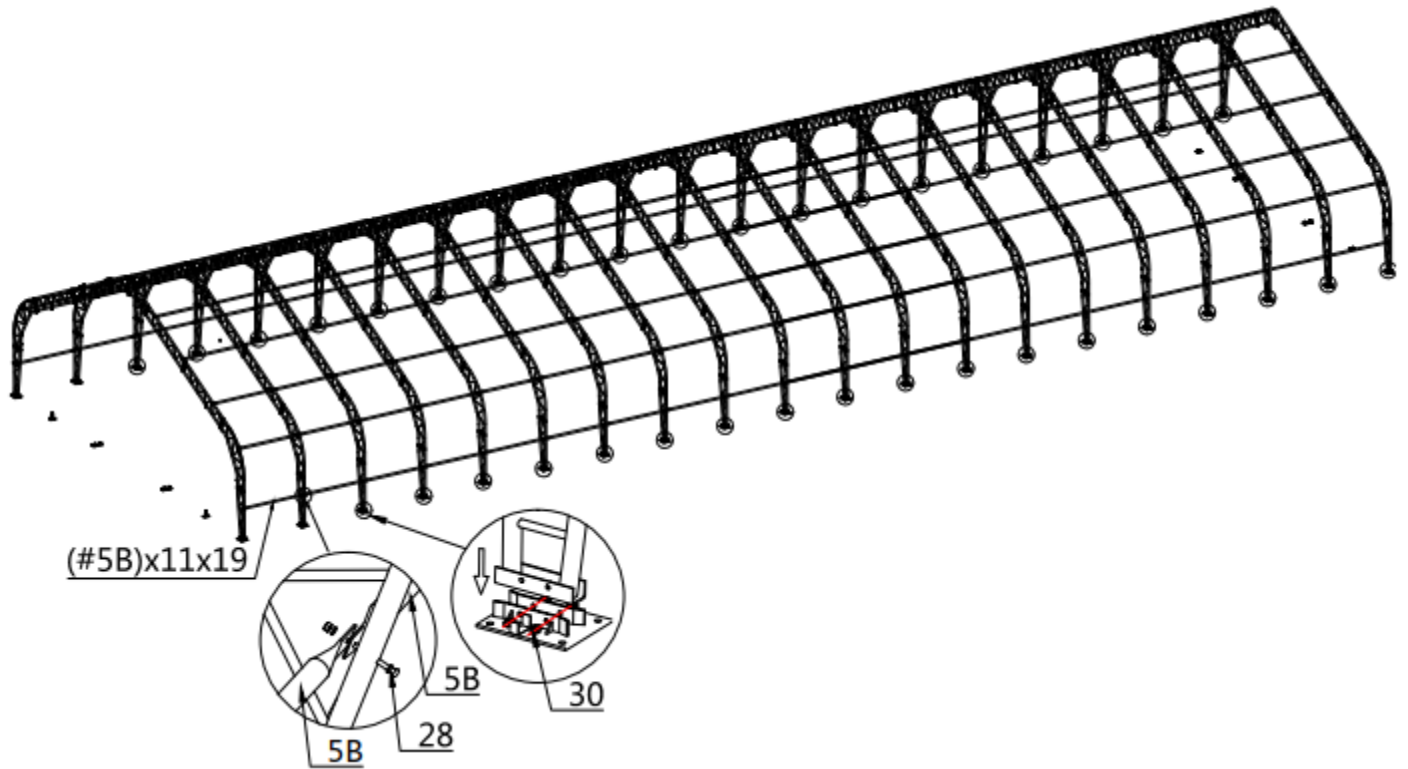

Step 7 : Repeat above step to put up all other trusses, and connect all purlins.

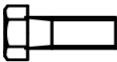
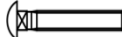

NO.	PART	Qty
5B		198
30		144
28		198

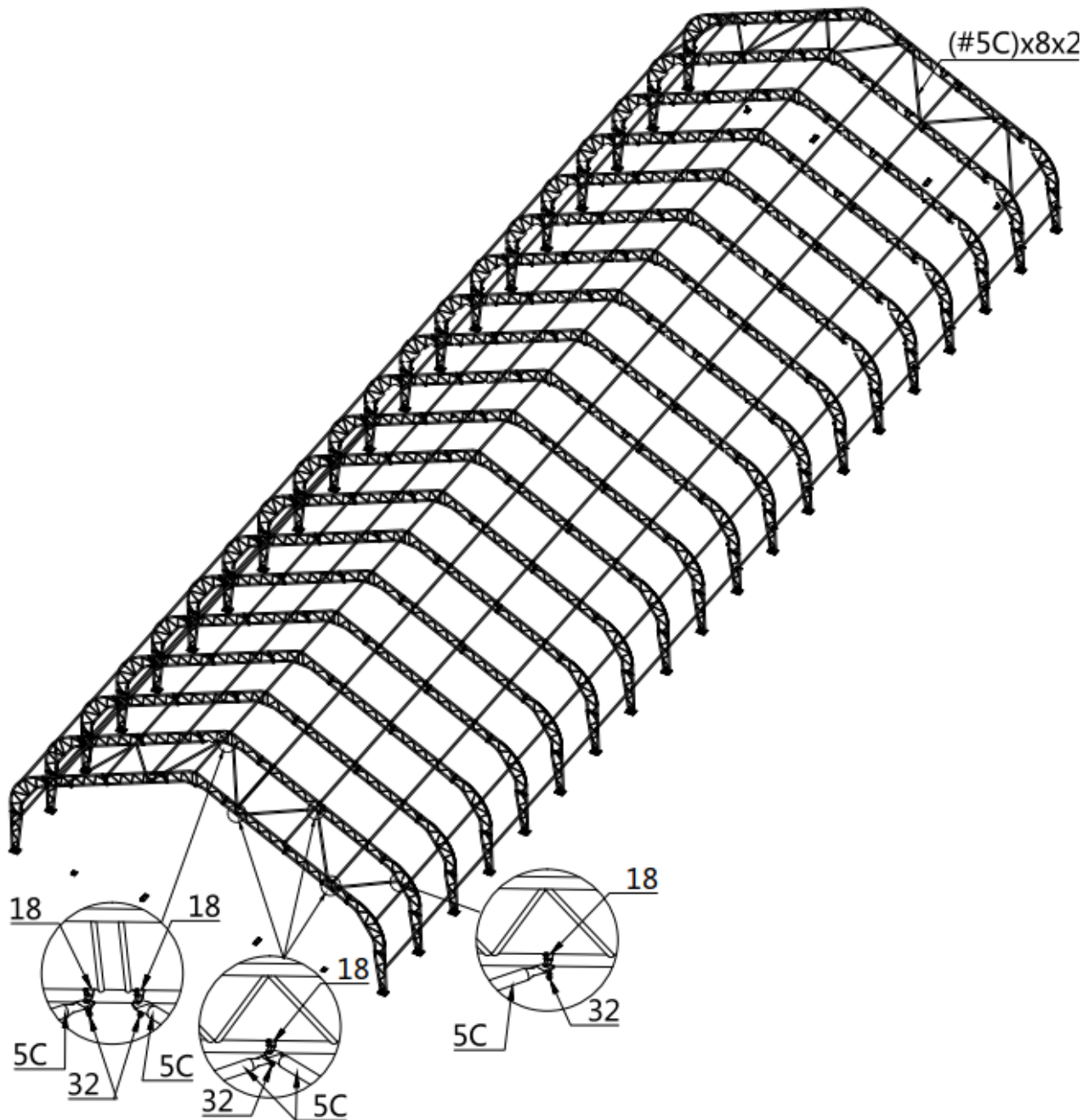

Step 8 : Installation of diagonal Purlins (the front and rear mounting methods are the same).

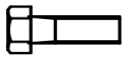

NO.	PART	Qty
5C		16
18		20
32		20

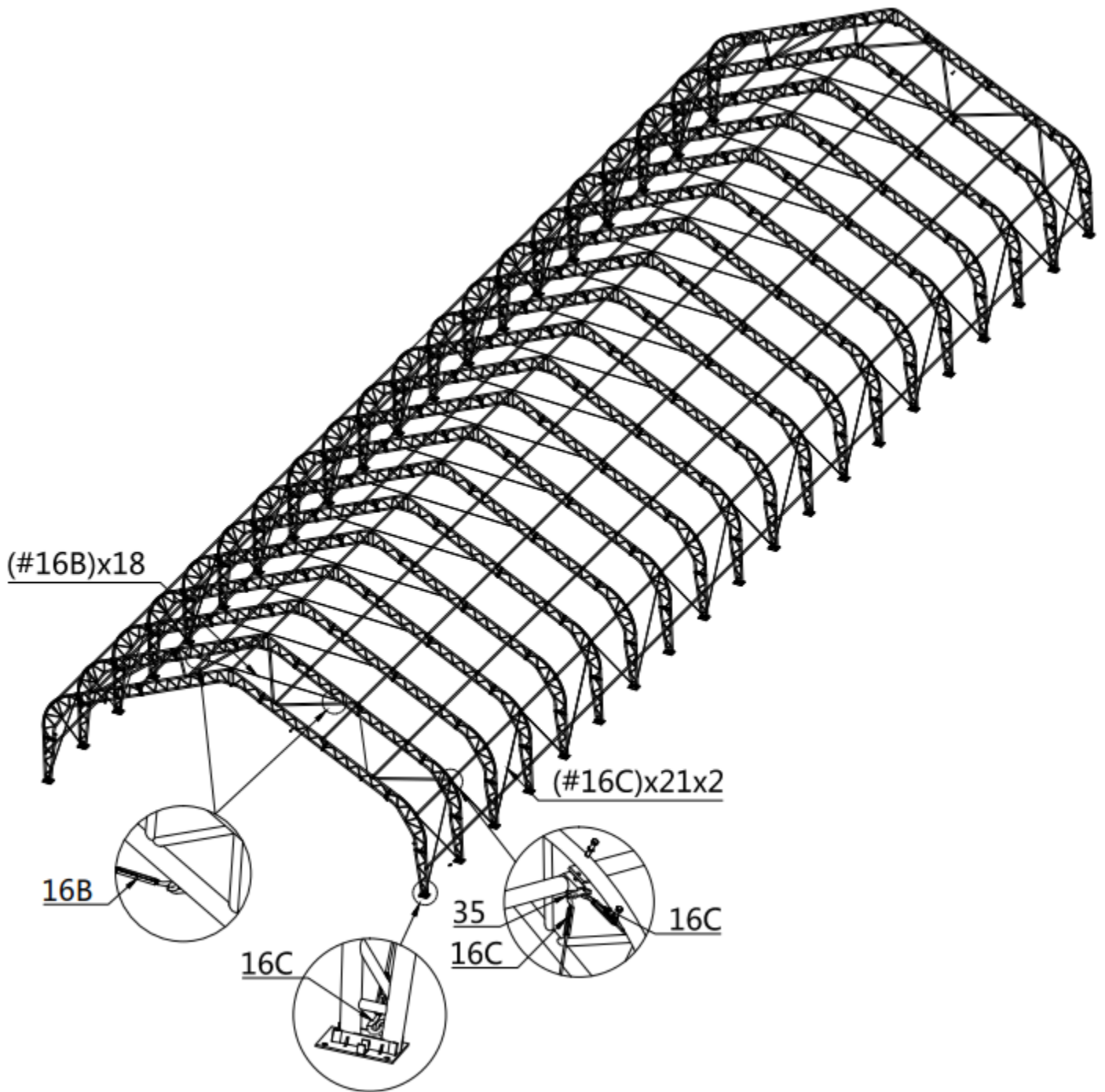
Step 9 : Tension cable installation, All cables are diagonally installed on each.



NO.	PART	Qty
16B		18
16C		42
35		24

Step 10 : Door column installation (the front and rear mounting methods are the same).

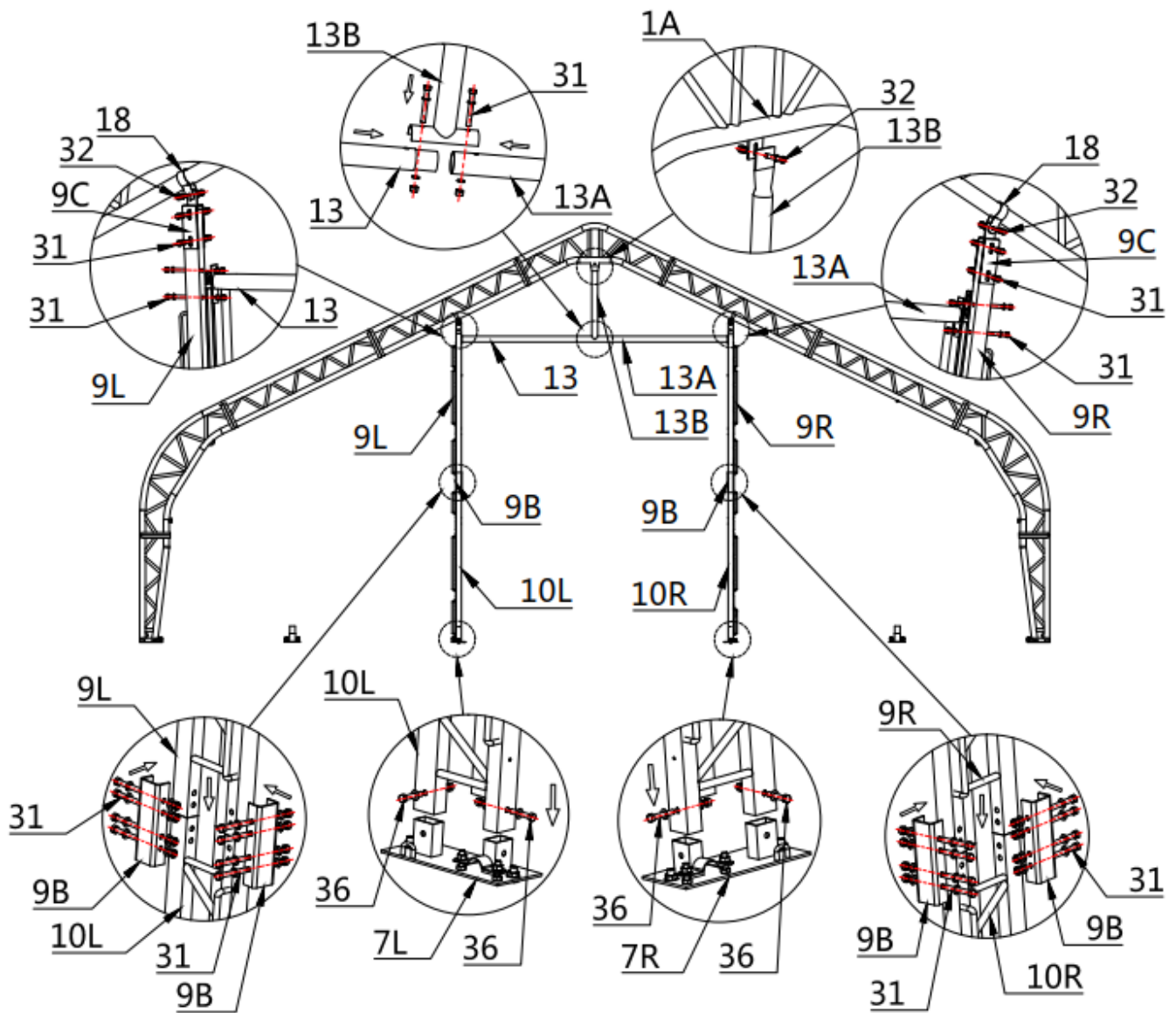

NO.	PART	Qty
9L		1
9R		1
9B		4
9C		2
10L		1

NO.	PART	Qty
10R		1
13		1
13A		1
13B		1
18		2

NO.	PART	Qty
31		26
32		3
36		4

Step 11 :

1. Door support pipe installation (the front and rear mounting methods are the same).

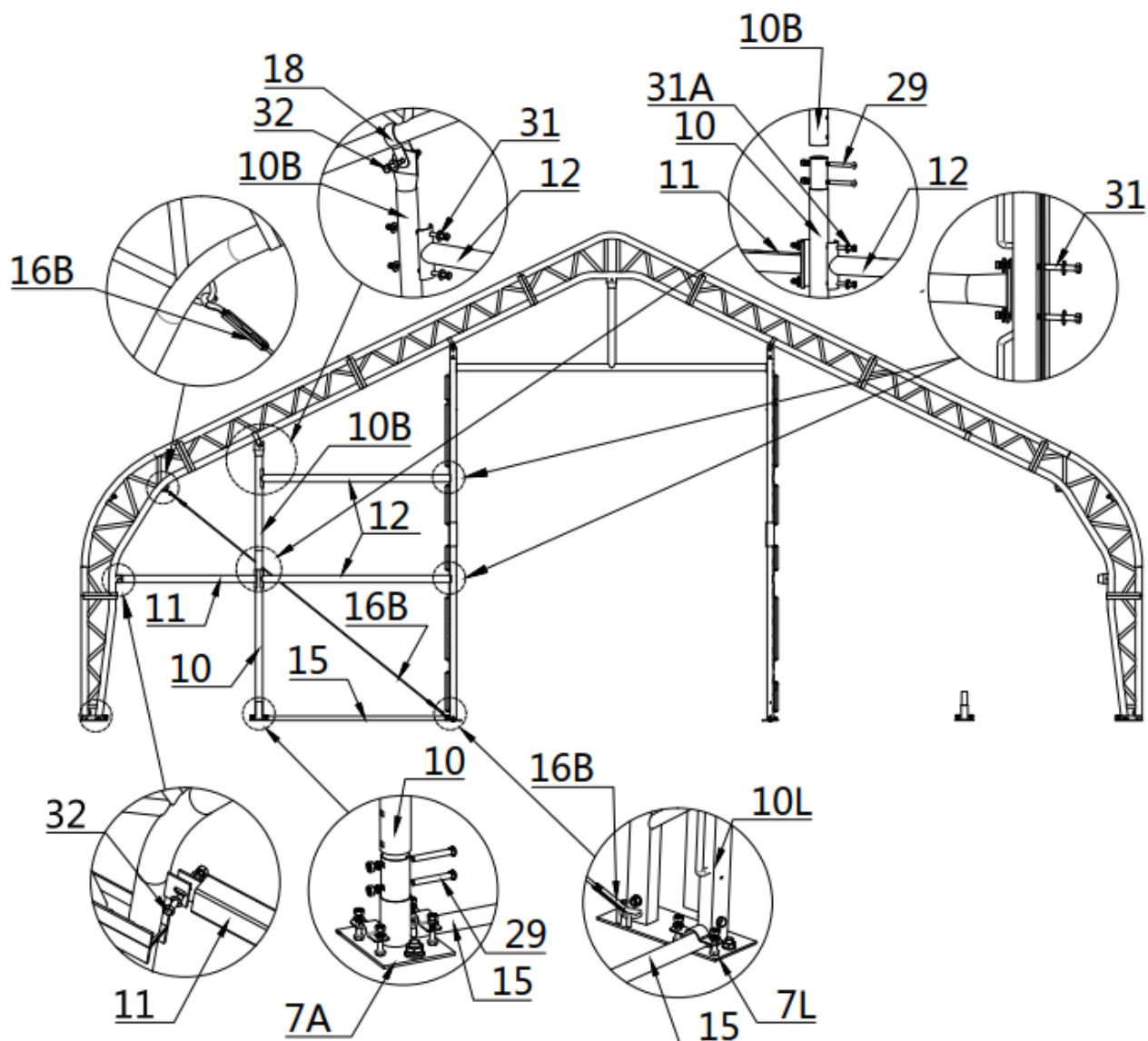

NO.	PART	Qty
10		1
10B		1
11		1
12		2

NO.	PART	Qty
15		1
16B		1
18		1
29		4

NO.	PART	Qty
31		6
31A		2
32		2

Step 11 :

2. Door support pipe installation (the front and rear mounting methods are the same).

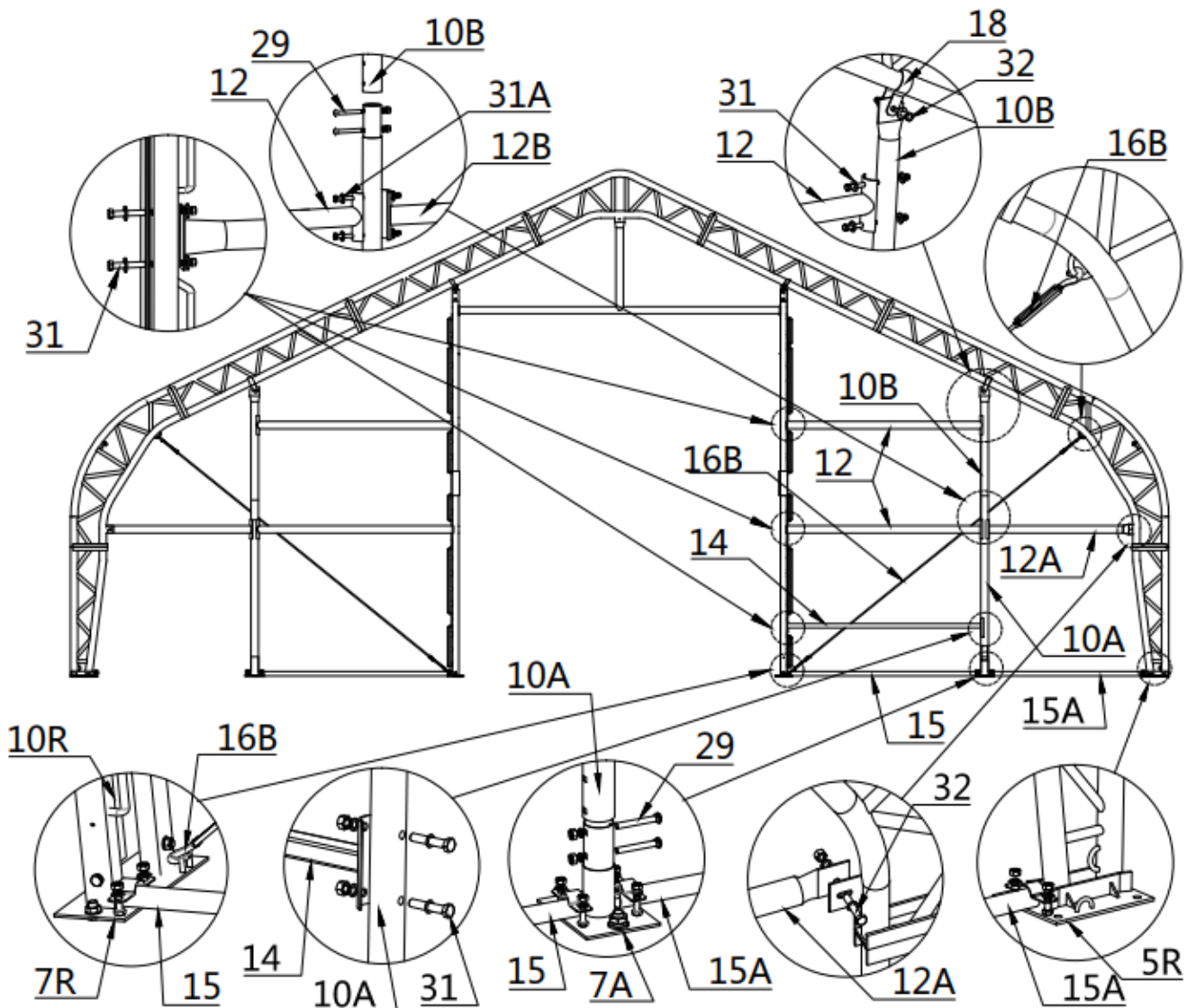

NO.	PART	Qty
10A		1
10B		1
12		2
12A		1

NO.	PART	Qty
14		1
15		1
15A		1
16B		1

NO.	PART	Qty
18		1
29		4
31		10
31A		2
32		2

Step 12 : Installation of side door column (the front and rear mounting methods are the same).

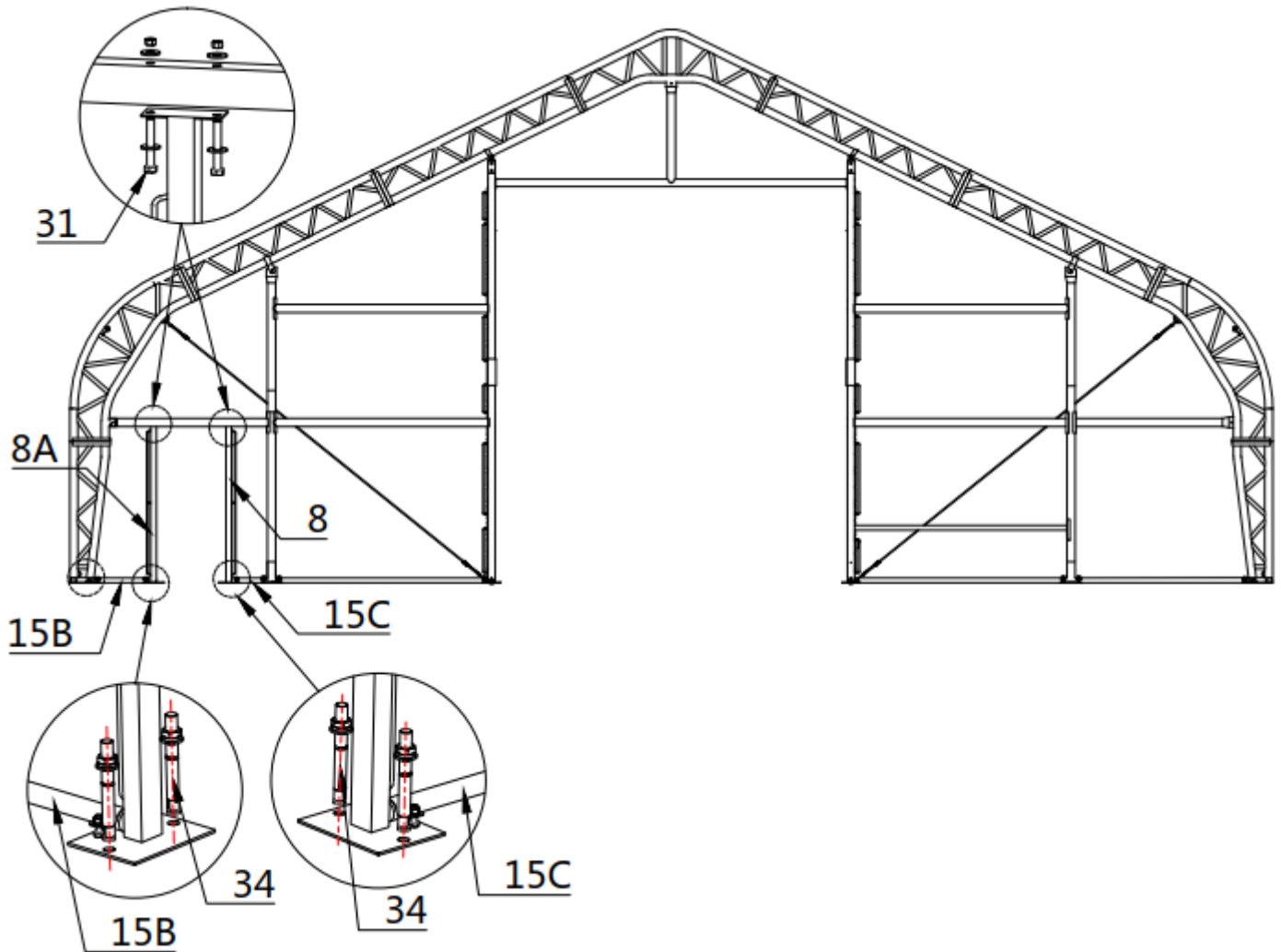



NO.	PART	Qty
8		1
8A		1
15B		1

NO.	PART	Qty
15C		1
31		4
34		4

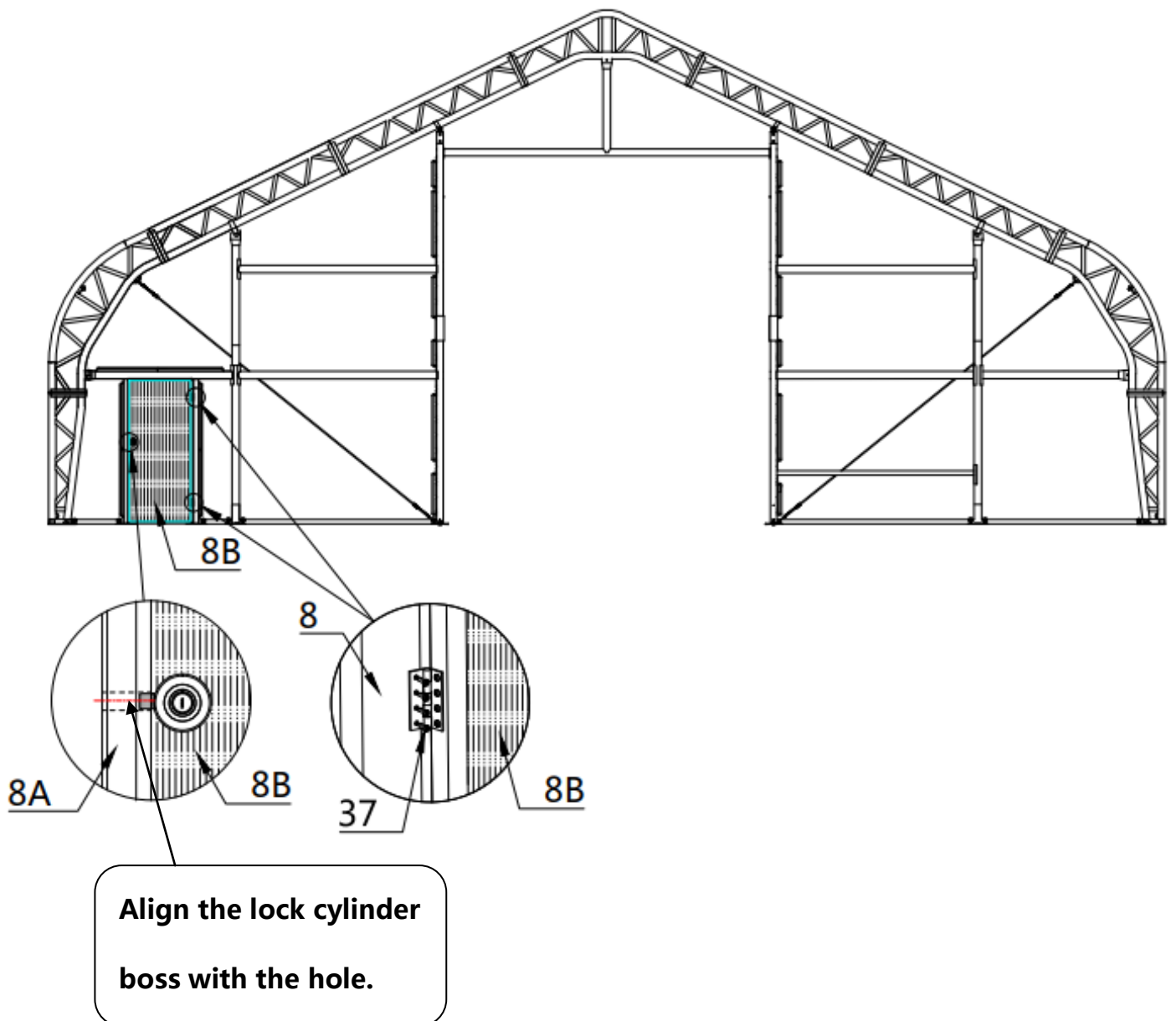
Step 13 : Install the side door (the front and rear mounting methods are the same).

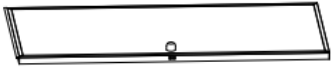

NO.	PART	Qty
8B		1
37		8

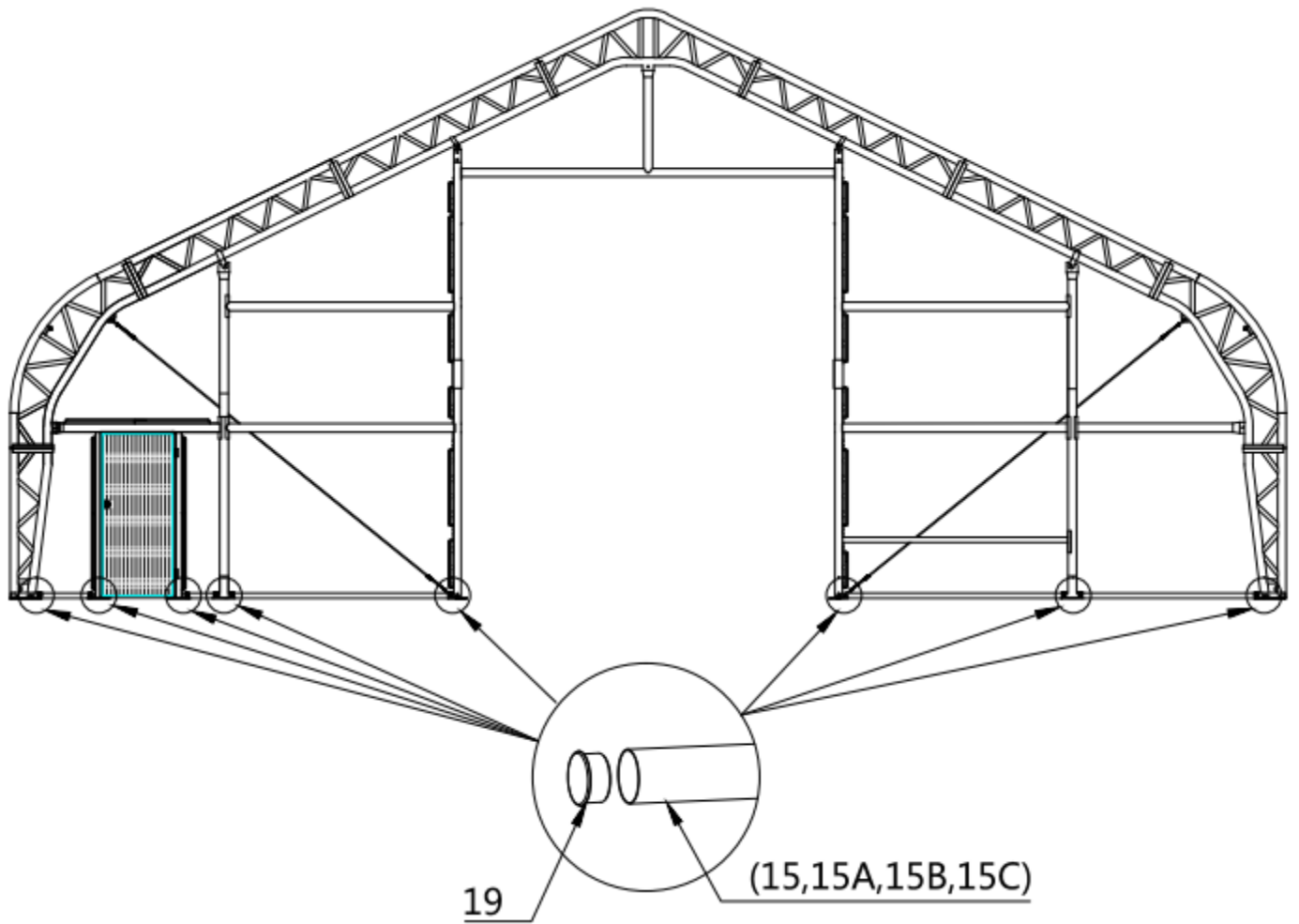

Step 14 : Install the waterproof plug (the front and rear mounting methods are the same).



NO.	PART	Qty
19		10

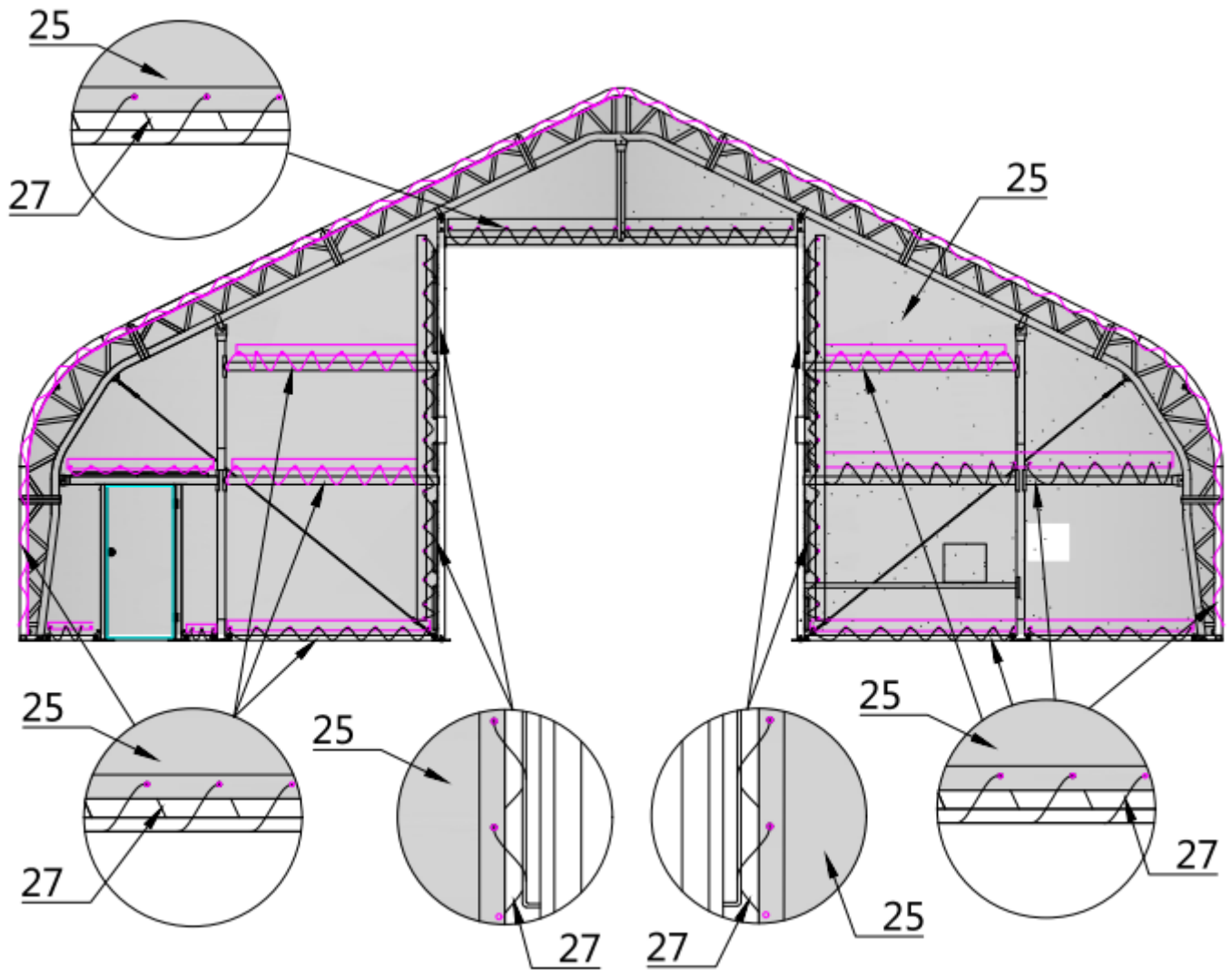

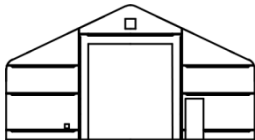
Step 15 : Install the door covering cloth (the front and rear mounting methods are the same).

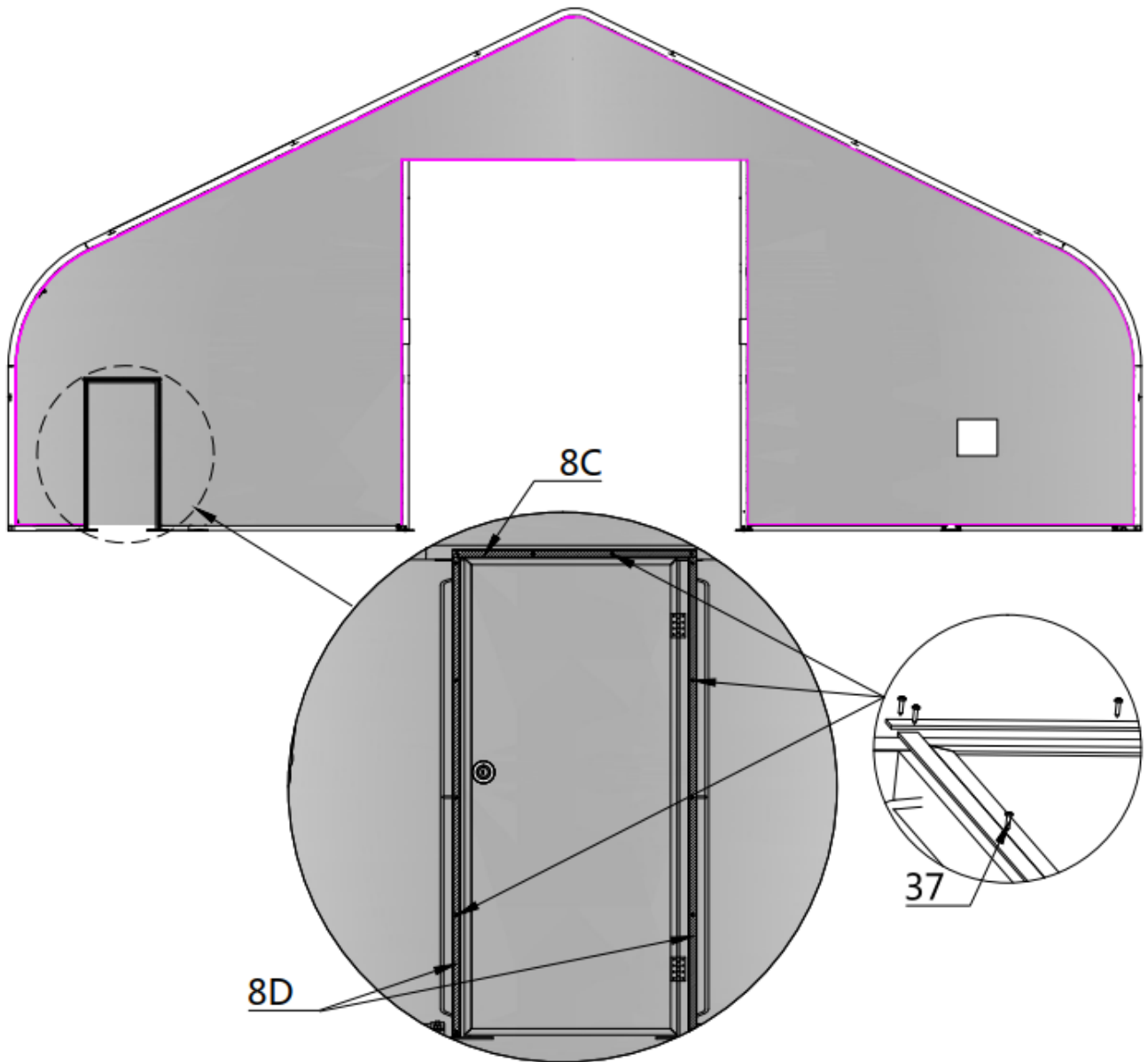

NO.	PART	Qty
25		1
27		1

Step 16 : Install the side door metal strip (the front and rear mounting methods are the same).



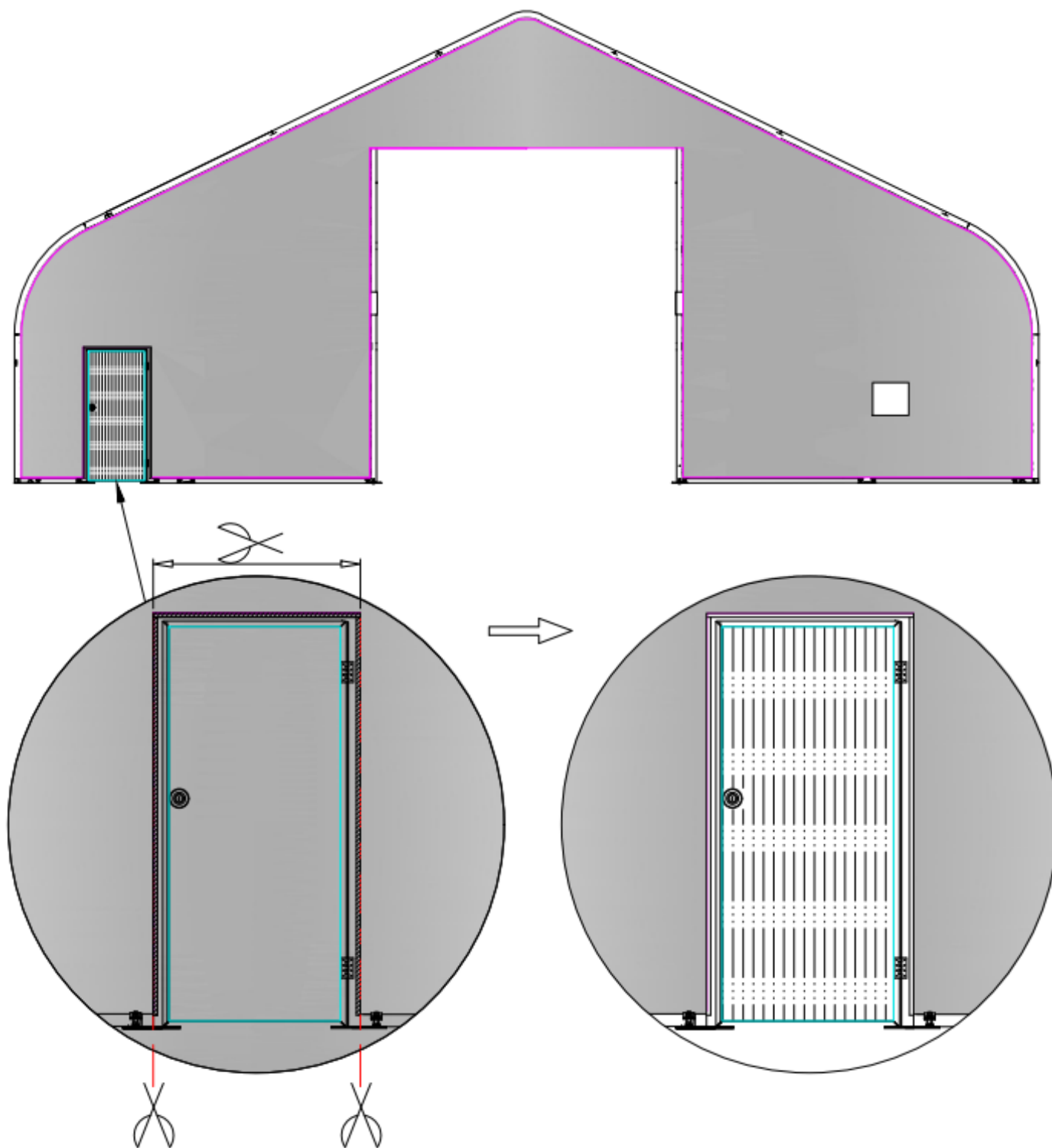

NO.	PART	Qty
8C		1
8D		2
37		20

Step17 : Cut open side door openings (the front and rear mounting methods are the same).

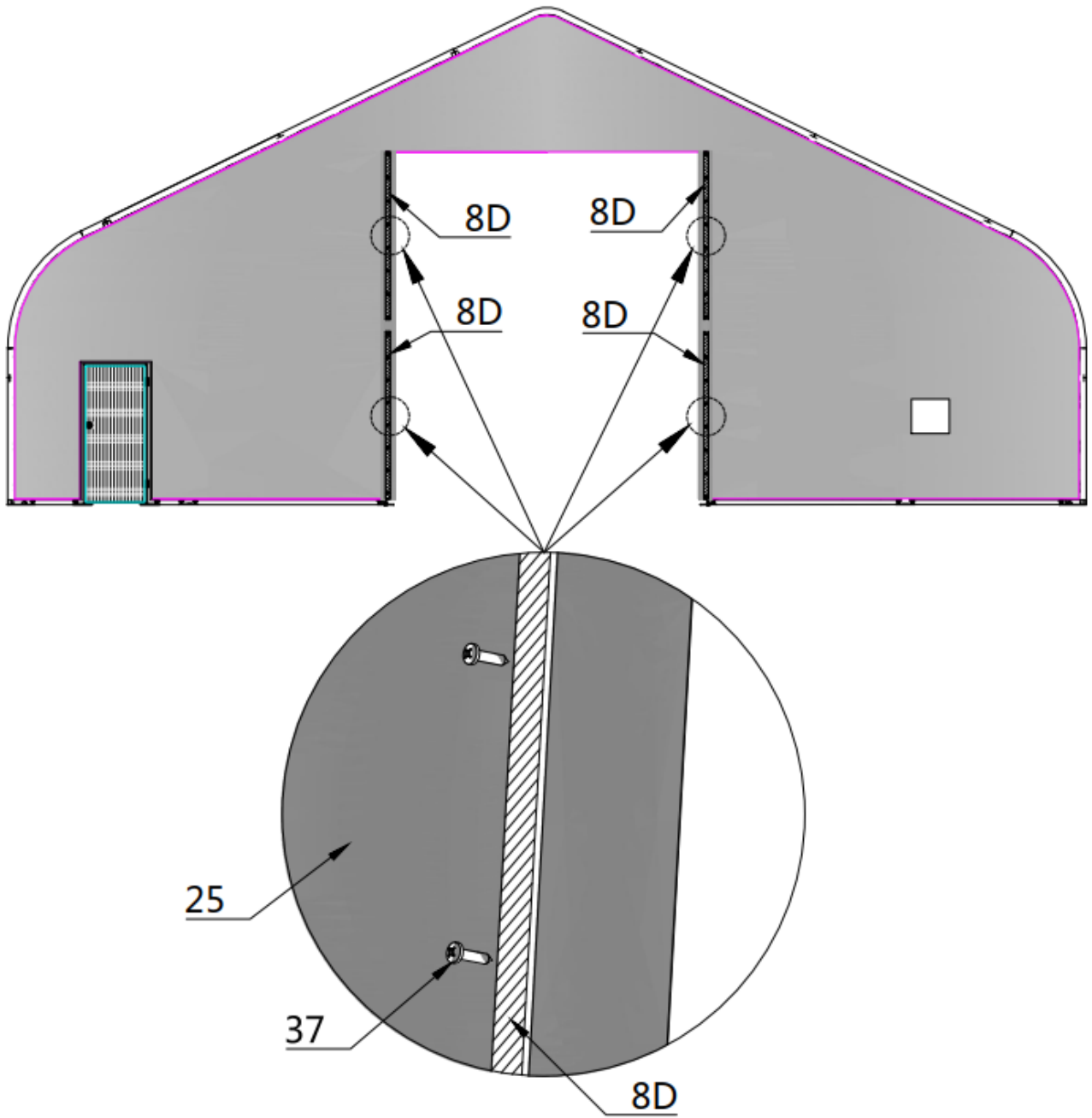

Step 18: Install the front door metal strip (the front and rear mounting methods are the same).





NO.	PART	Qty
8D		4
37		32

Step 19 :

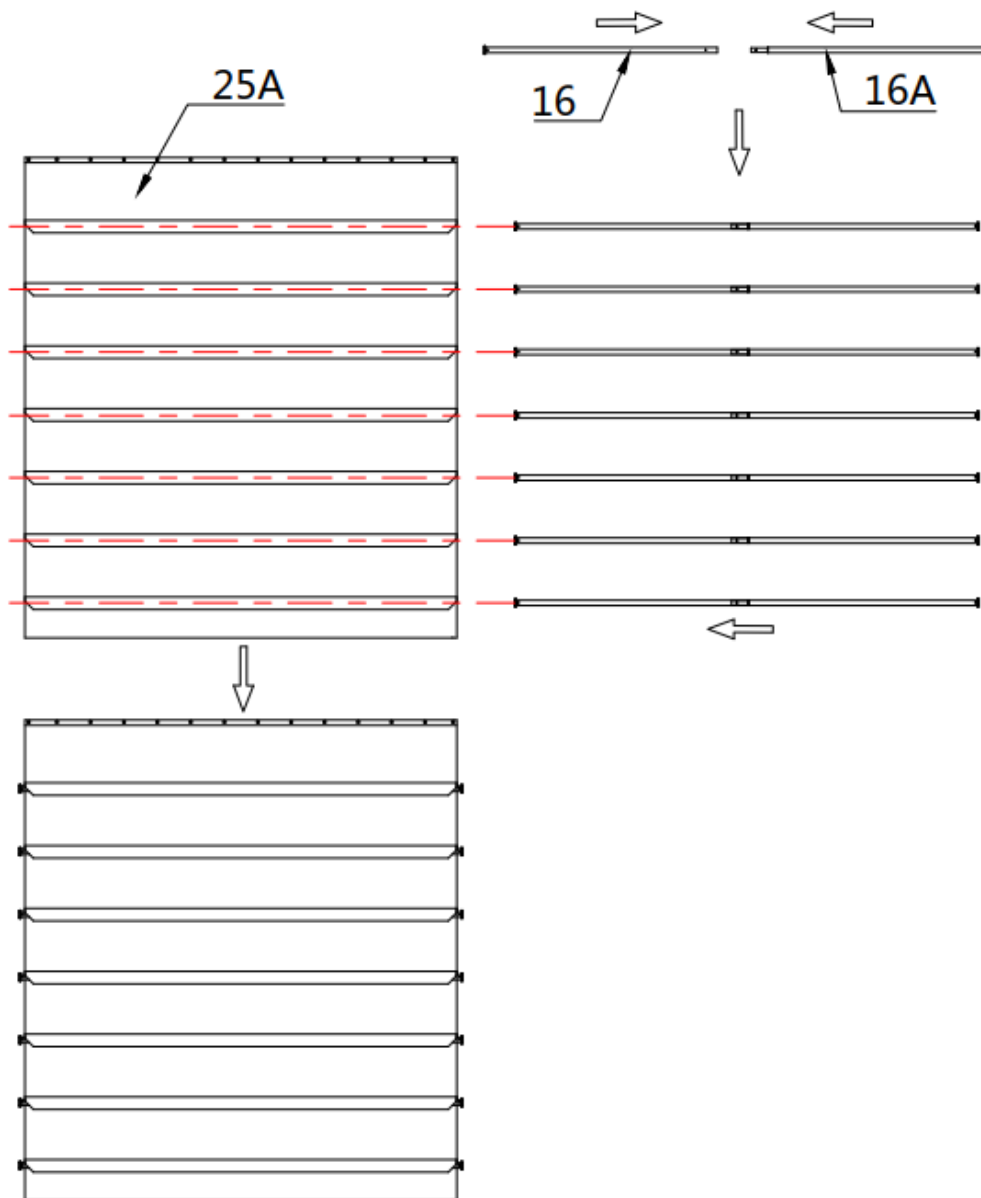
1. Door curtain installation (the front and rear mounting methods are the same).



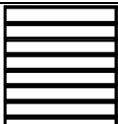

NO.	PART	Qty
16		7
16A		7
25A		1

Step 19 :

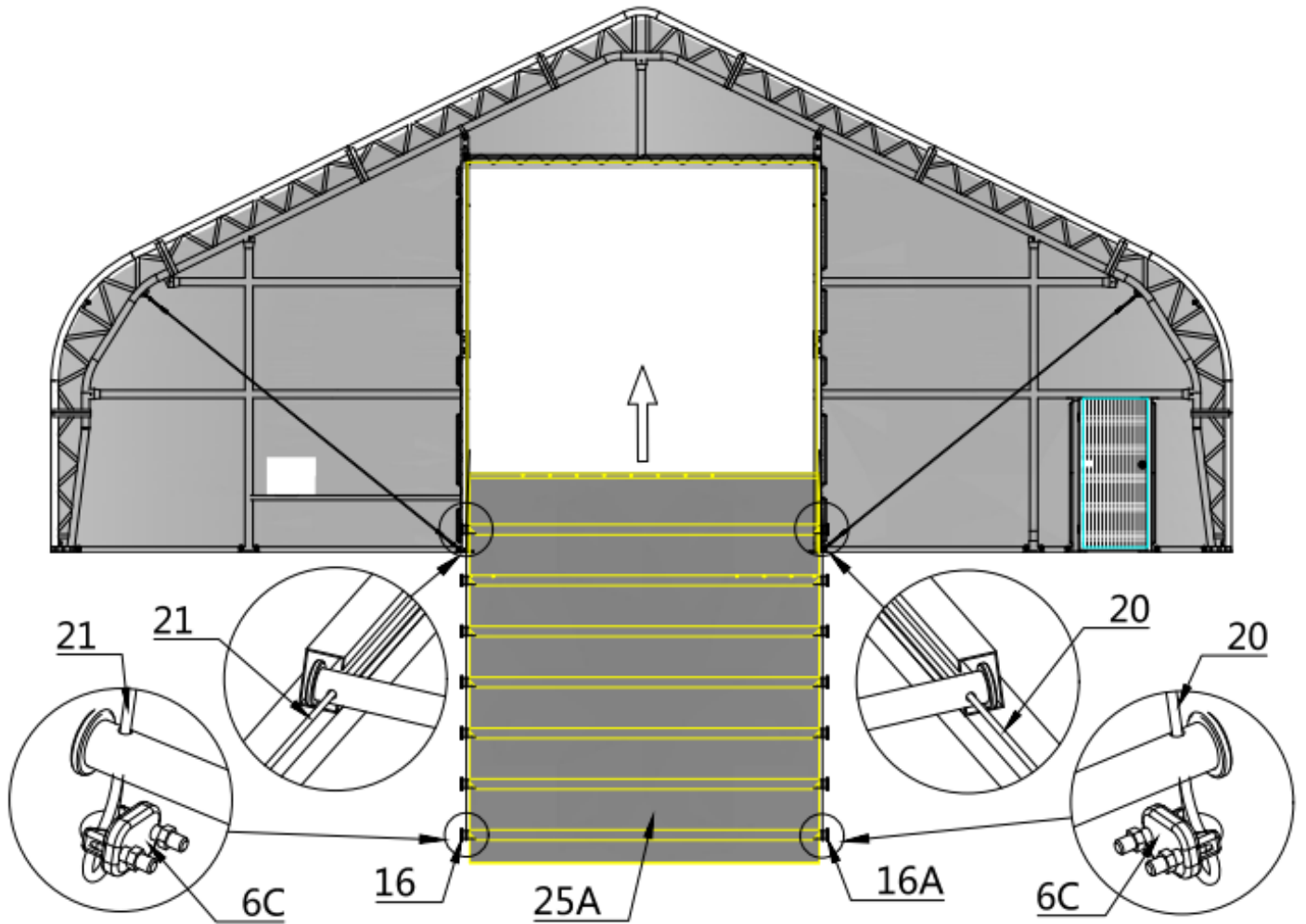
2. Door curtain installation (the front and rear mounting methods are the same).



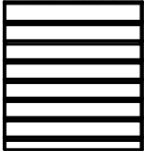

NO.	PART	Qty
6C		2
21		1
25A		1

Step 19 :

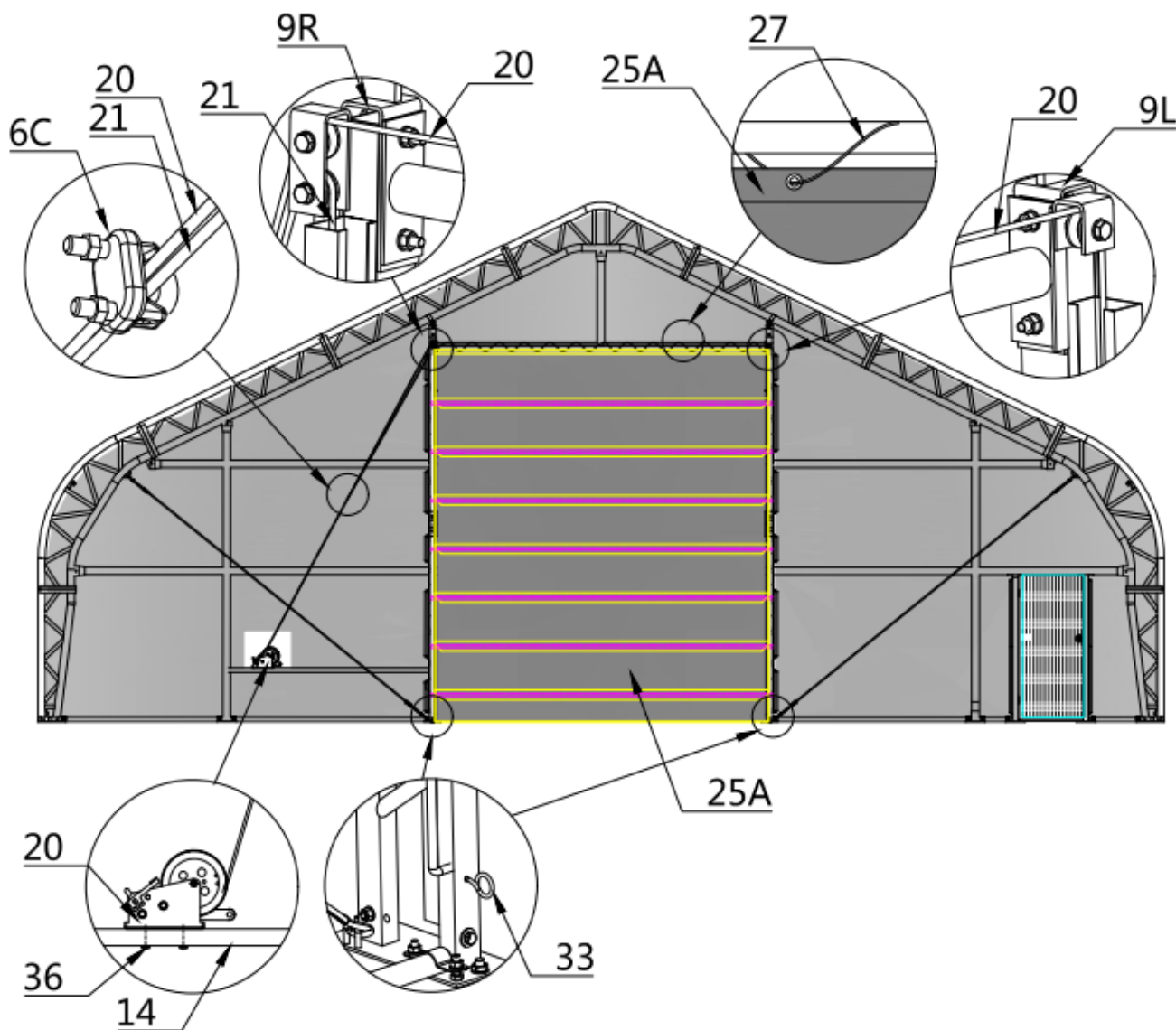
3. Door curtain installation(the front and rear mounting methods are the same).

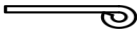
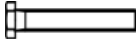

NO.	PART	Qty
6C		1
20		1
27		1
33		1
36		2

Step 20 :

1. Install the top cloth (#24A) .

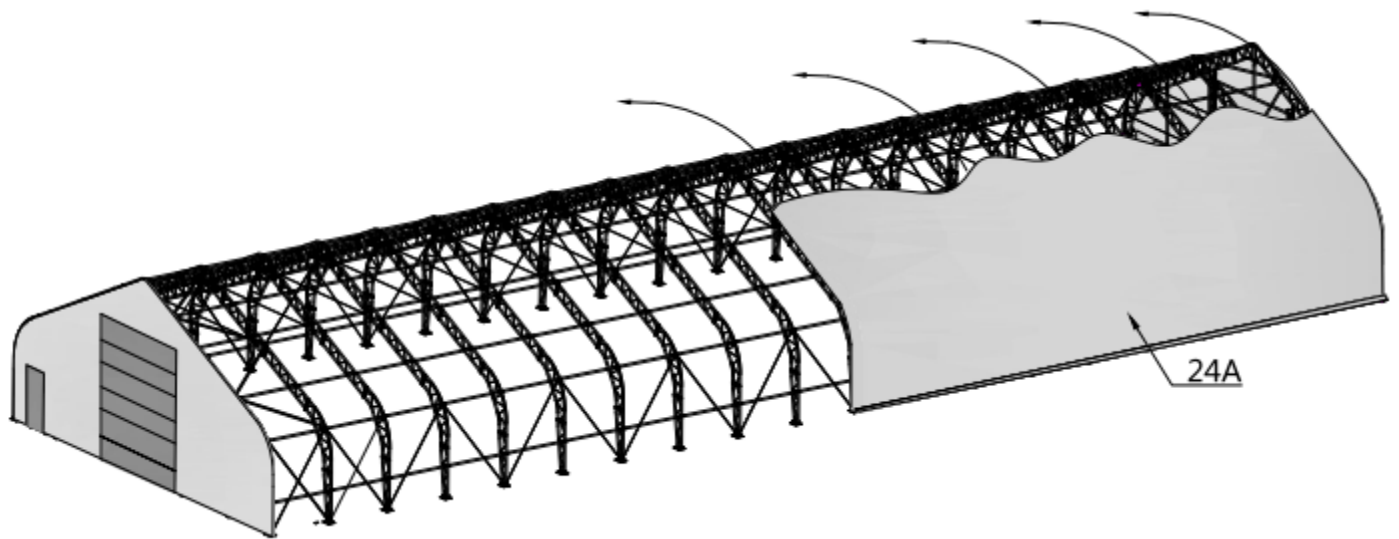

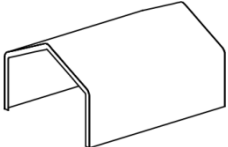

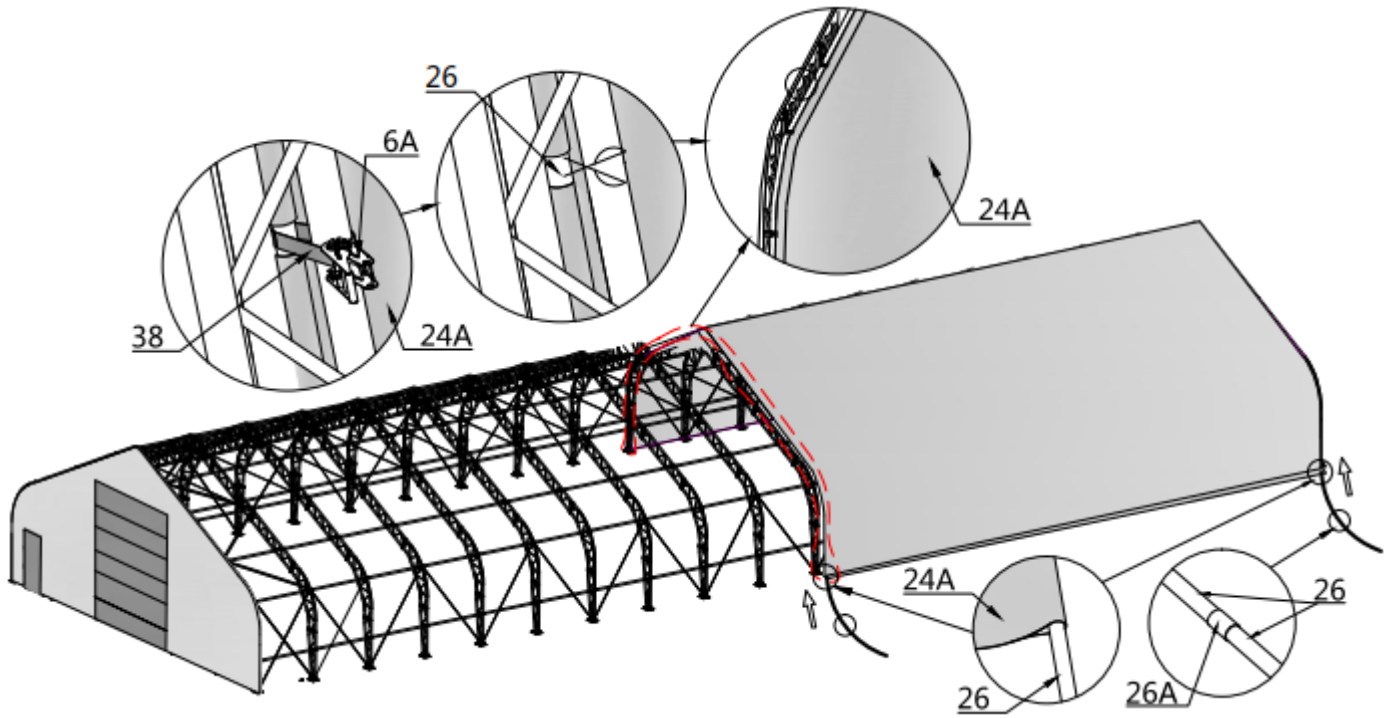

NO.	PART	Qty
24A		1

Step 20 :

2. Install the top cloth (#24A) .





NO.	PART	Qty
6A		18
26		6
26A		5
27		1
38		18

Step 20 :

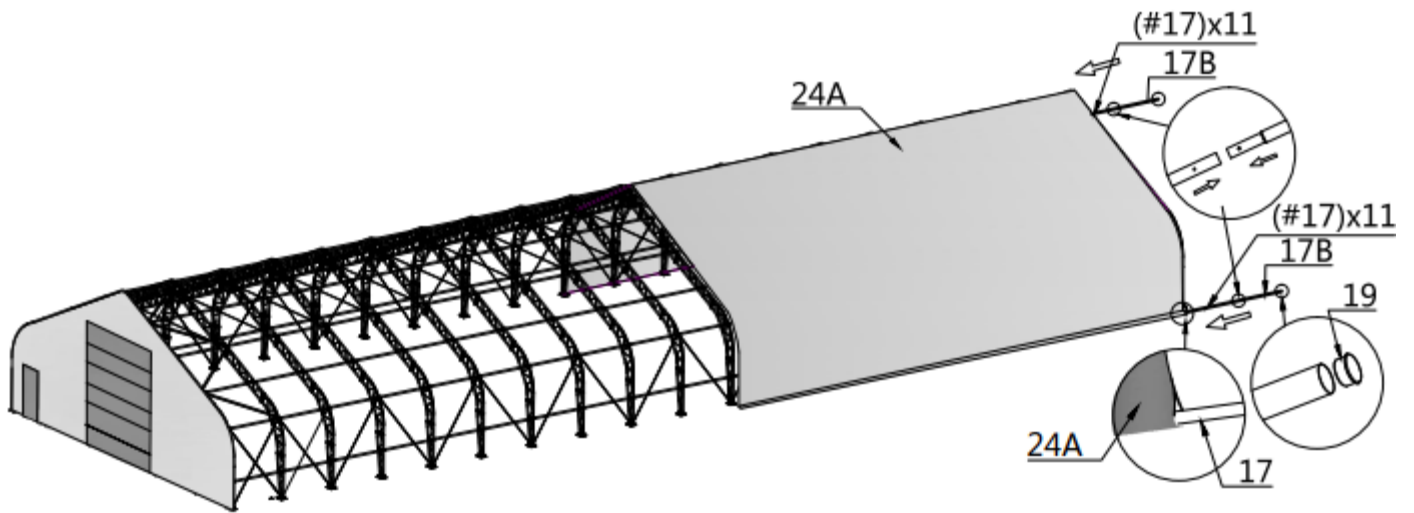
3. Install the top cloth (#24A) .

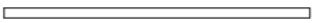
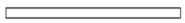



NO.	PART	Qty
17		22
17B		2
19		4

Step 20 :

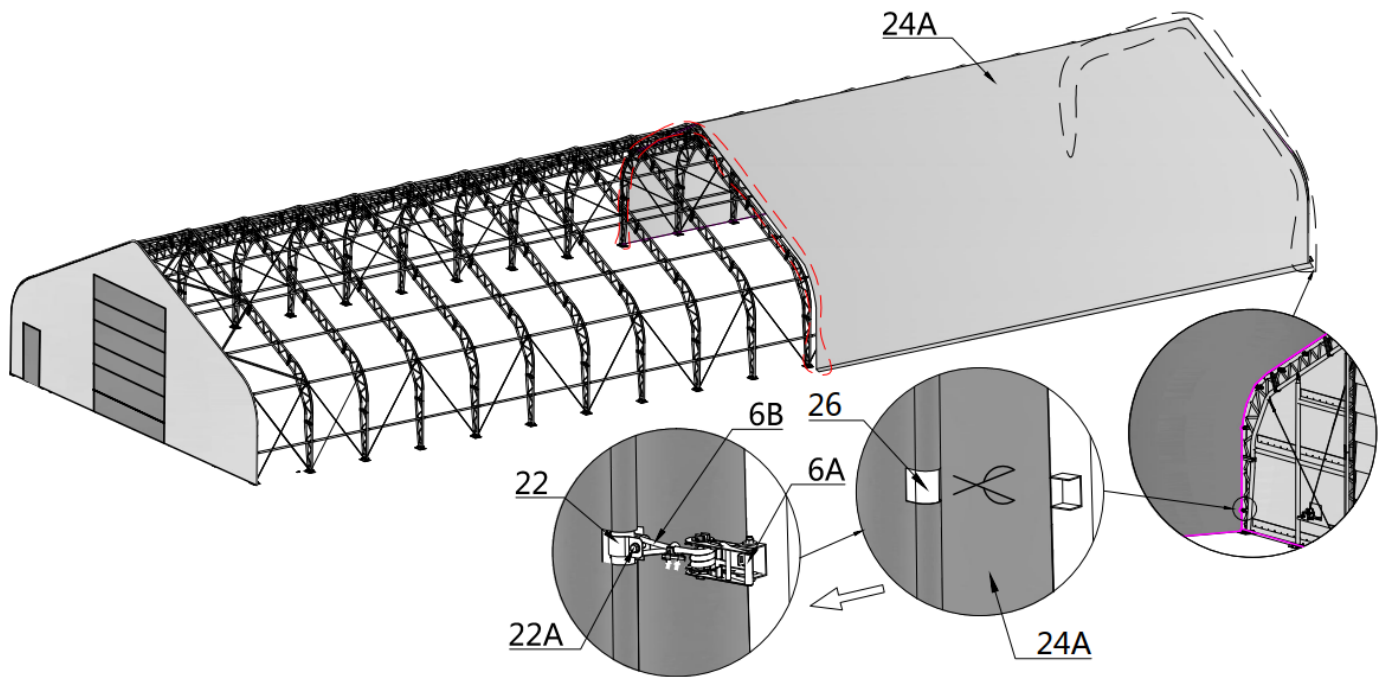
4. Install the top cloth (#24A) .

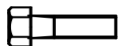

NO.	PART	Qty
6A		18
6B		18
22		18
22A		18

Step 21 :

1. Install the top cloth (#24) .

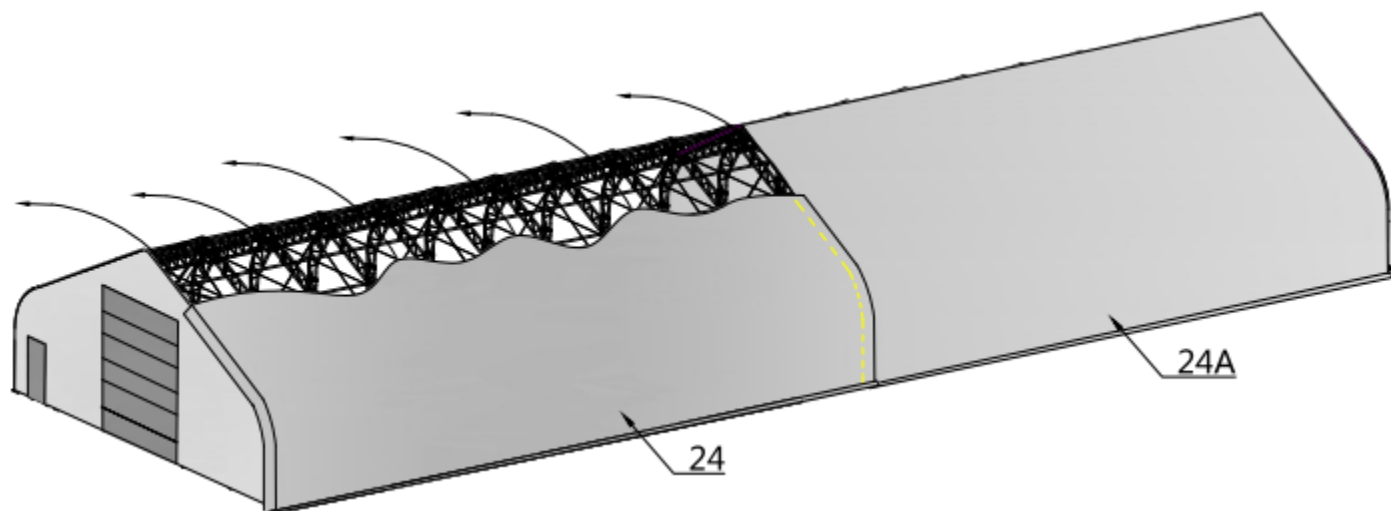

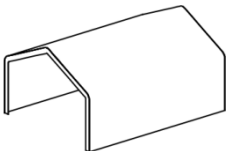

NO.	PART	Qty
24		1

Step 21 :

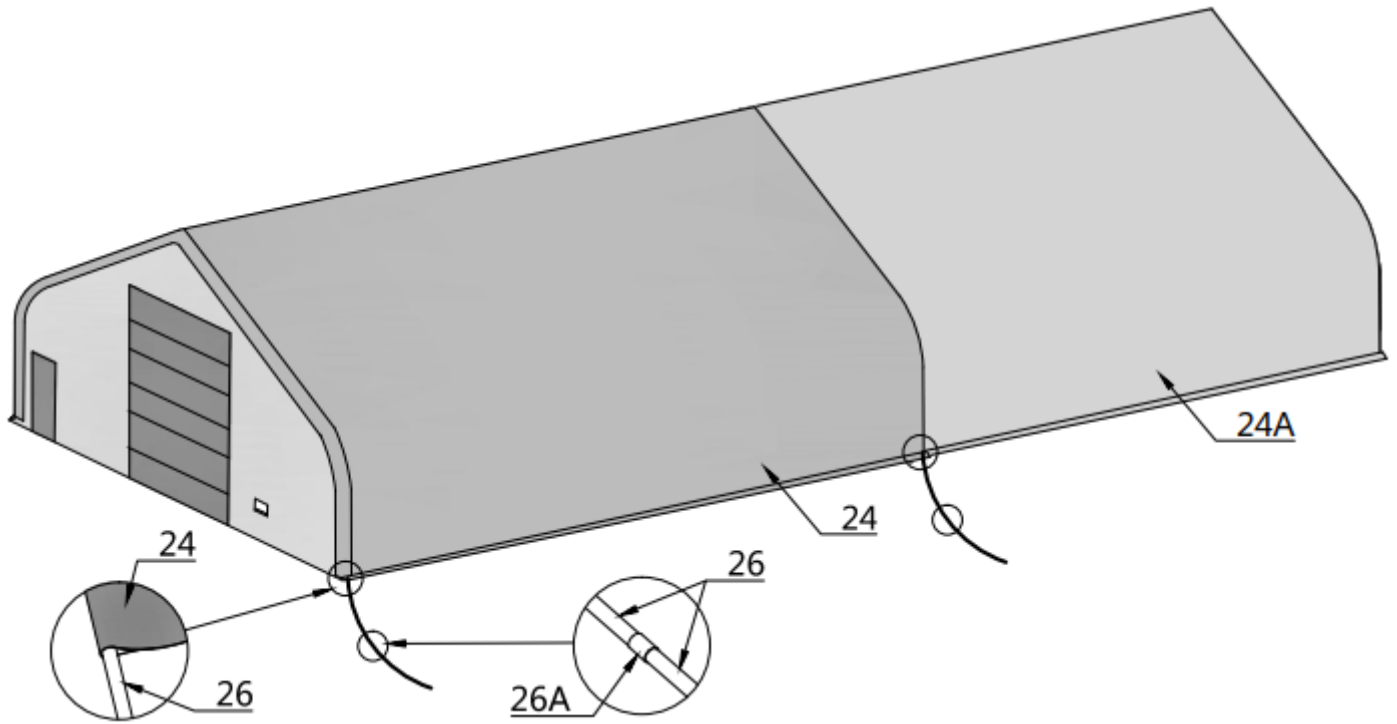
2. Install the top cloth (#24) .





NO.	PART	Qty
26		12
26A		10

Step 21 :

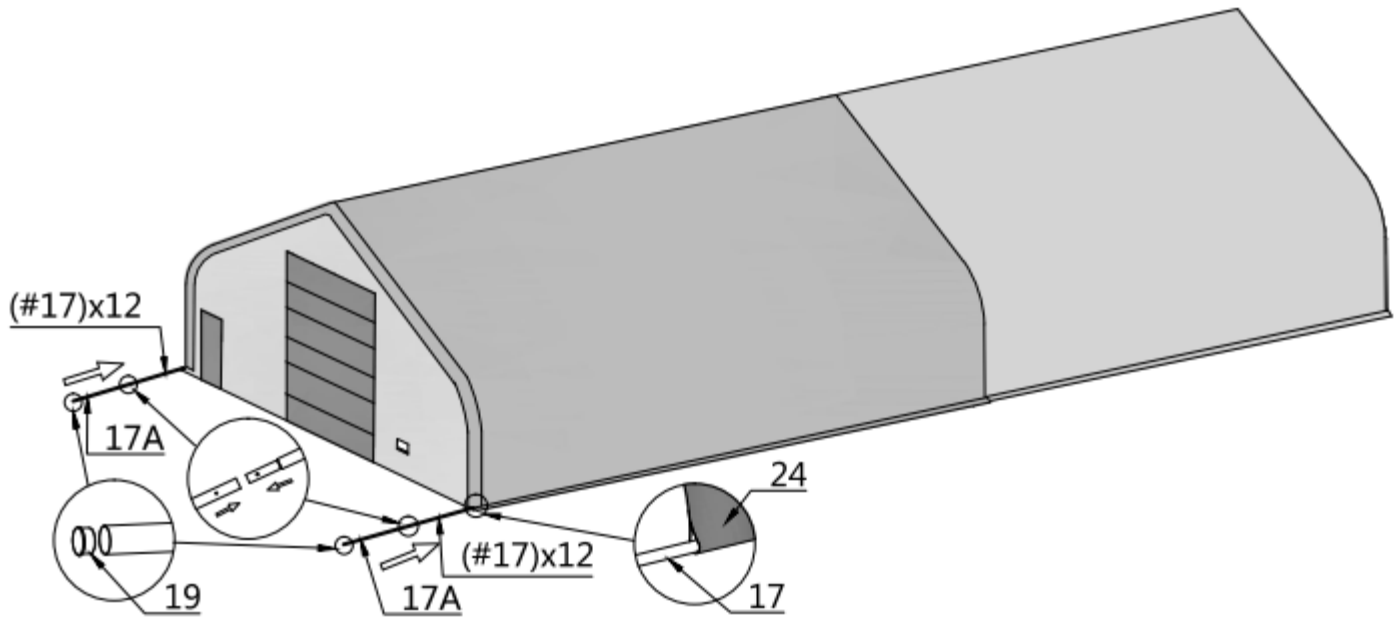
3. Install the top cloth (#24) .





NO.	PART	Qty
17		24
17A		2
19		4

Step 21 :

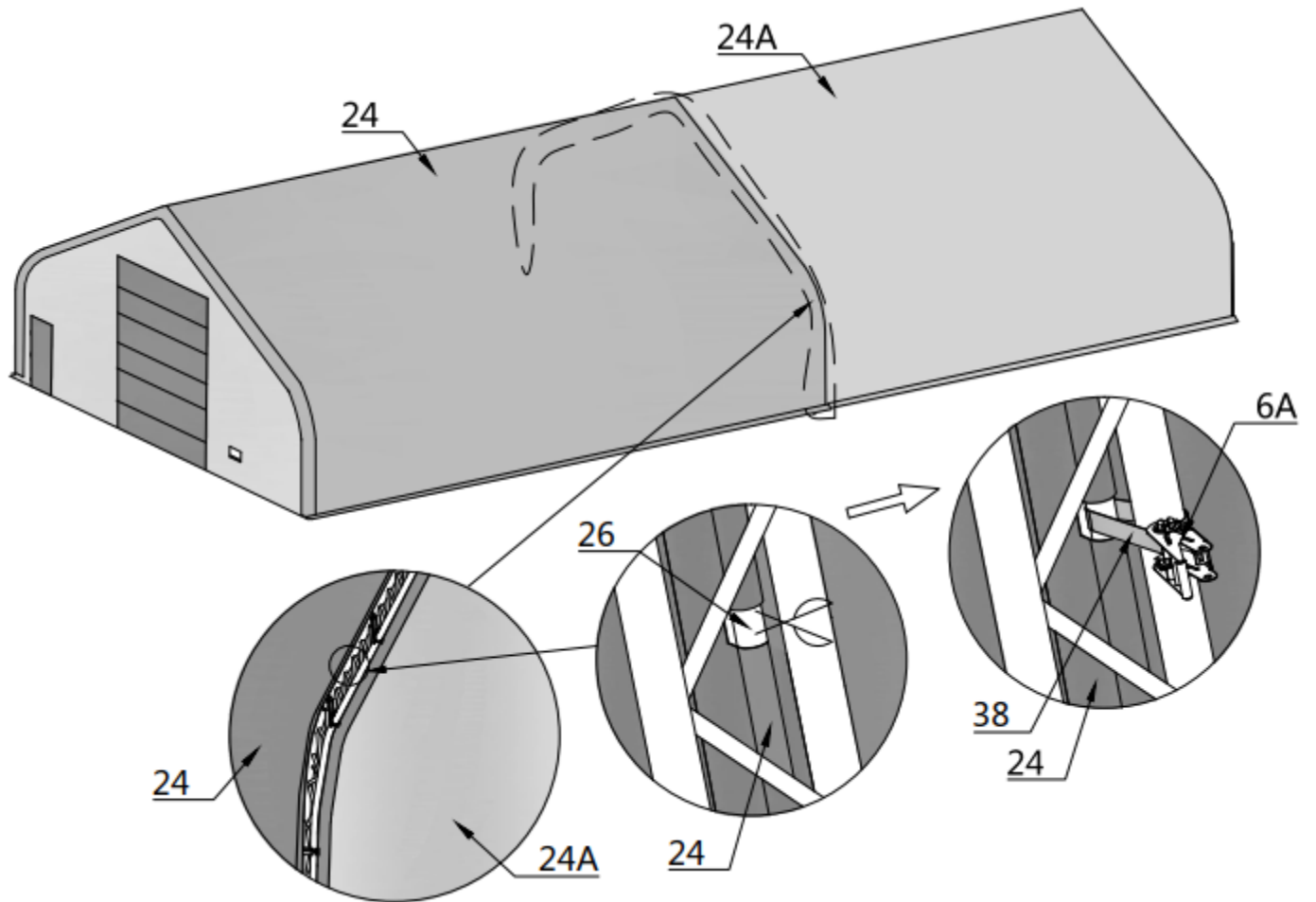
4. Install the top cloth (#24) .





NO.	PART	Qty
6A		18
38		18

Step 21 :

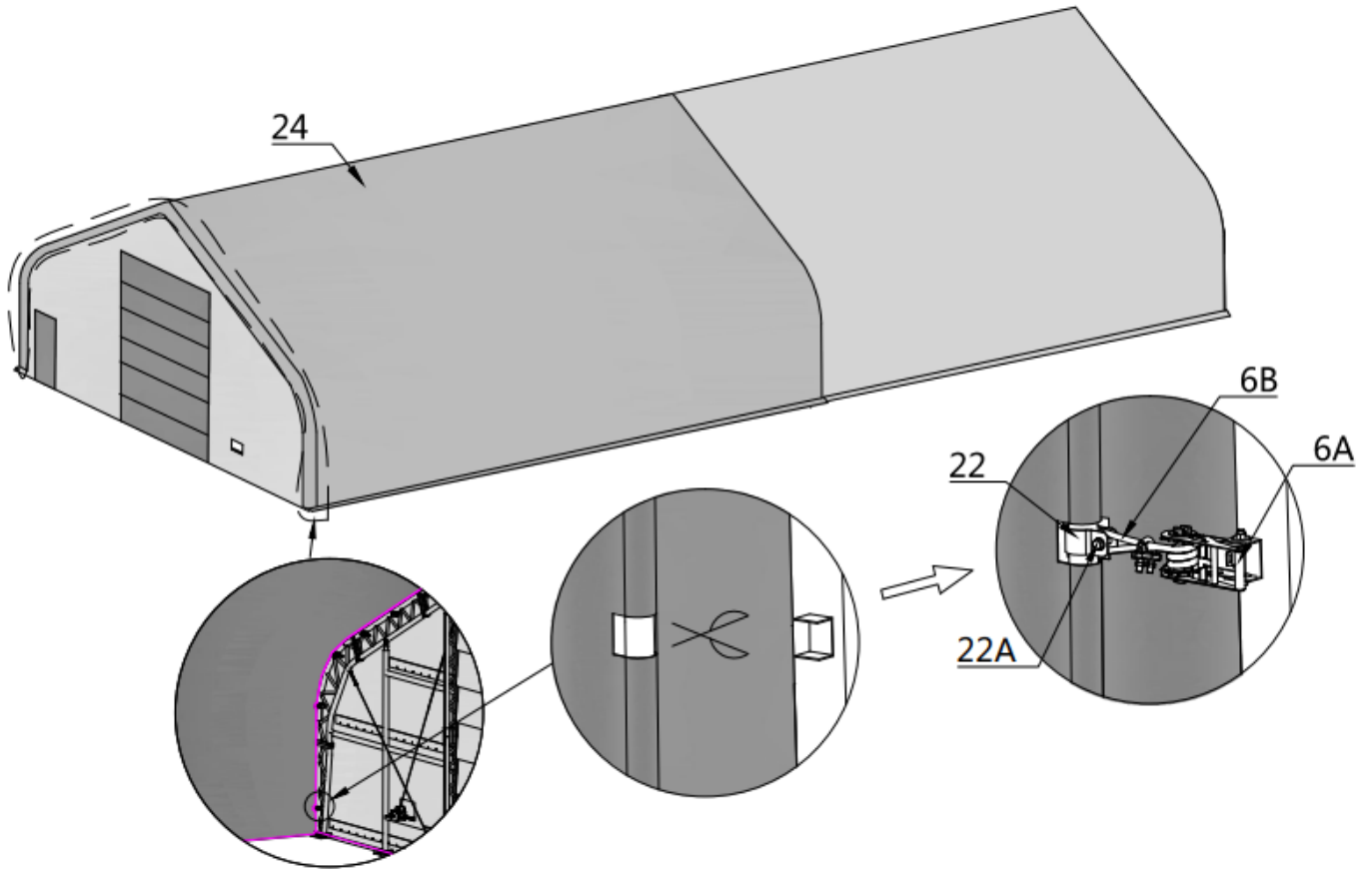

5. Install the top cloth (#24) .

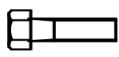

NO.	PART	Qty
6A		18
6B		18
22		18
22A		18

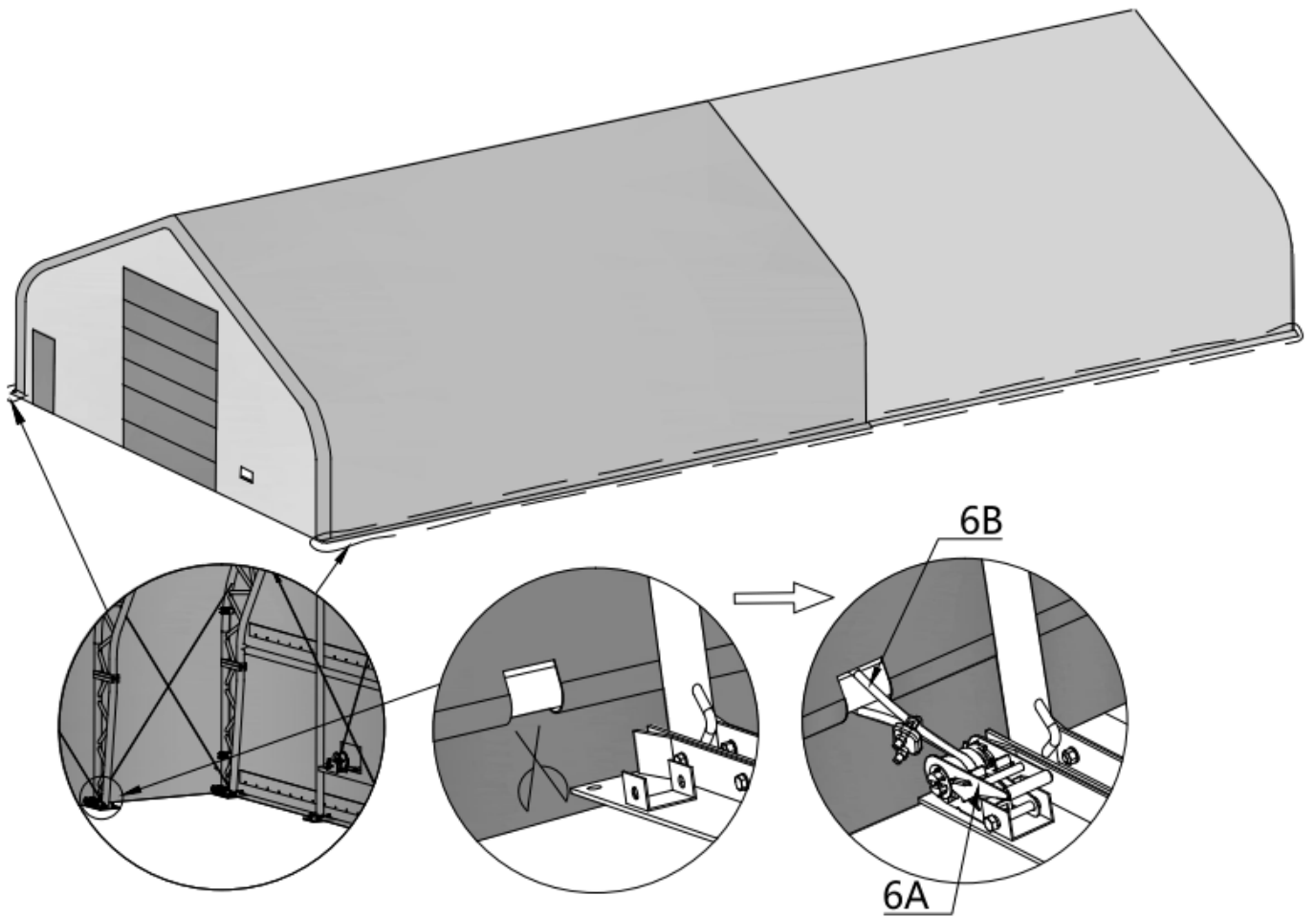
Step 22 : Tension both sides of the top cloth with the tension device.



NO.	PART	Qty
6A		44
6B		42

Step 23 : Tie the rope.

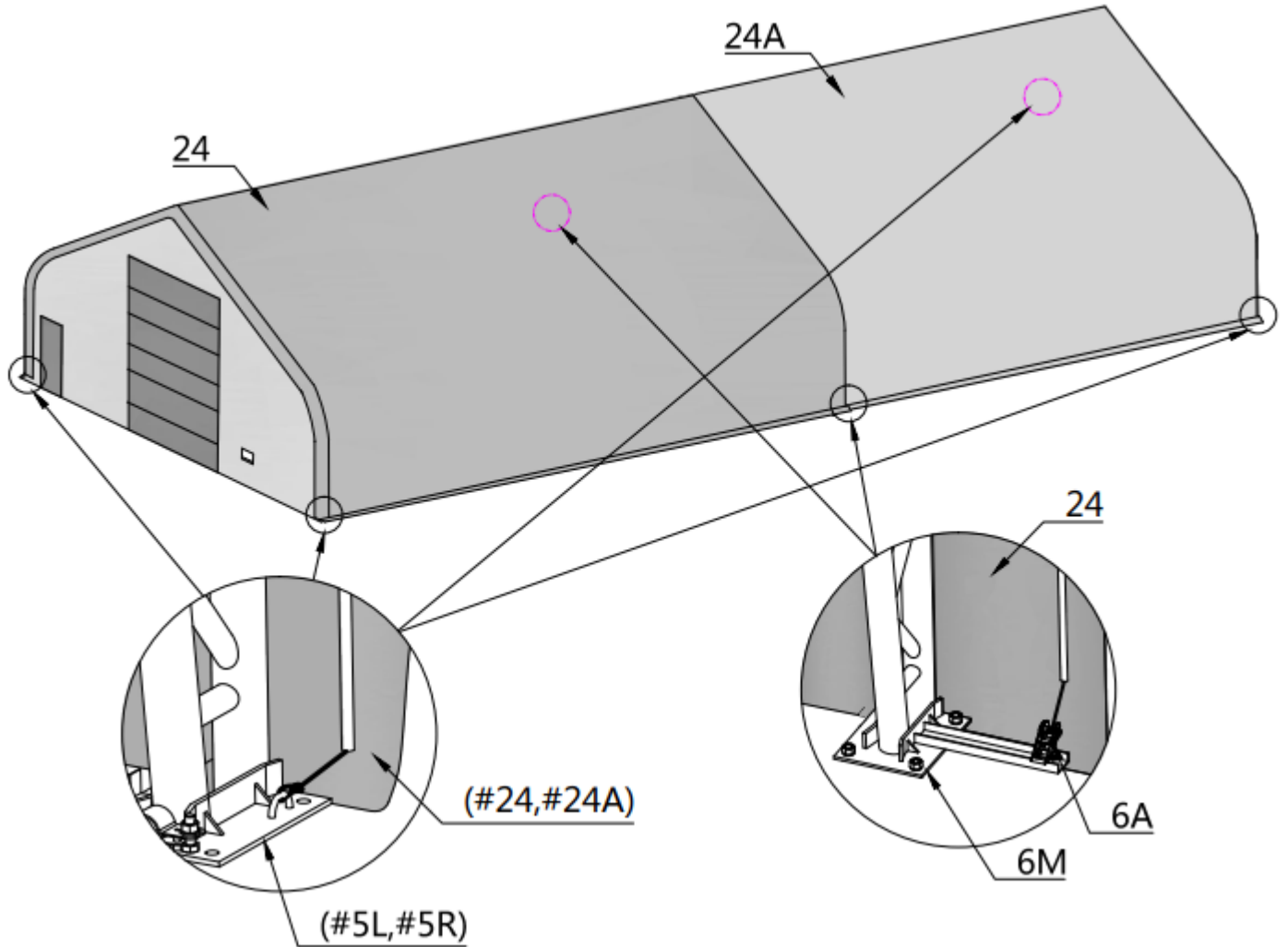

NO.	PART	Qty
6A		2

After the Installation

Walk around and inspect the building periodically to make sure all components are still firmly secured and the whole building is well supported. Check all bolts and nuts as well as all connection points to make sure they are all in good position. Check the base plates, adjust the ropes and tie downs if required and clean the cover regularly.

Snow accumulating on the fabric cover must be removed as soon as possible. If snow becomes solid ice on the cover, it will increase the weight on the roof and collapses the building or reduce the life span eventually.

Keep the building on a dry ground most of the time. Do not keep the fabric dirt skirt under water all the time, otherwise the fabric will deteriorate.

We strongly recommend you remove any snow from the roof immediately. Do not leave any snow load on the roof overnight. Keep 3 feet of clearance on all sides at all times. Do not allow snow to accumulate and pile up on the sides of the building. Otherwise the push from the sides toward inside will make the building collapsed at some point.