

# 50' X 100' DUAL TRUSS PRO SERIES STORAGE SHELTER

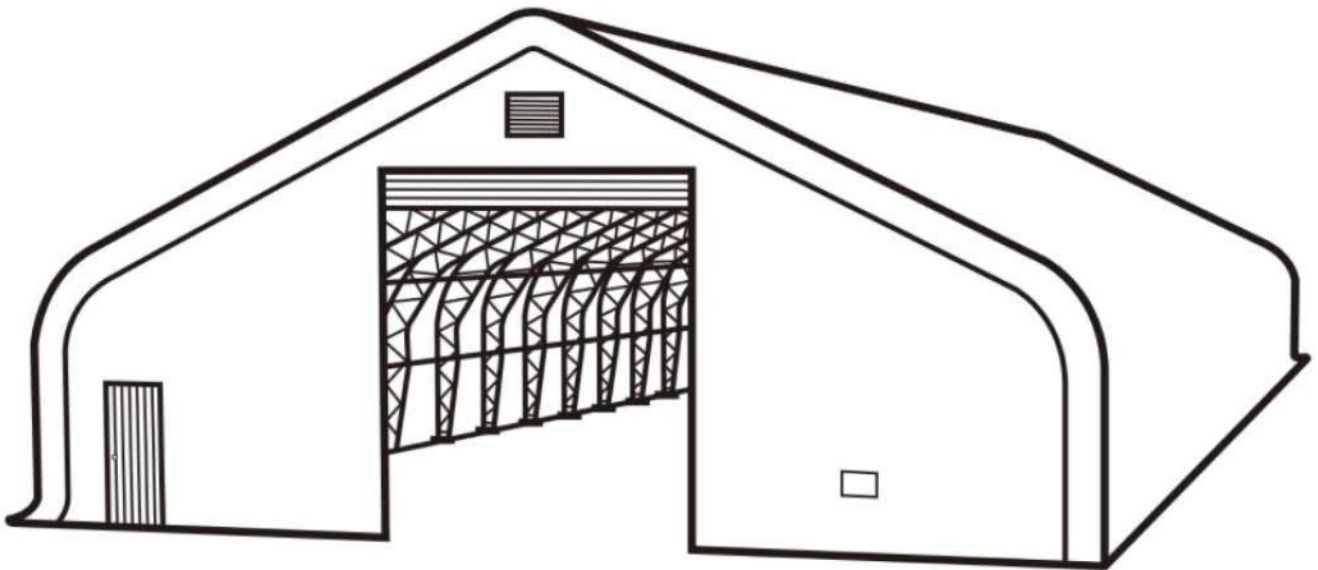

- Please read and understand the product manual completely before assembly
- Check against the parts list to make sure all parts are received
- Wear proper safety goggles or other protective gears while in assembly
- Do not return the product to dealer. They are not equipped to handle your requests.

Missing parts or have questions on assembly?  
Please call: 1-877-761-2819 or email: [cs@tmgindustrial.com](mailto:cs@tmgindustrial.com)

**MAIN SPECIFICATIONS :**

- Assembly size : W15.24 x L31.2 x H7.0 (m) / 50 x 102.4 x 23 (ft)
- Outside width : 15.24 m / 50ft, inside width : 14.4 m / 47.4 ft, length : 31.2 m / 102.4 ft
- Ridge peak height : 7.0 m / 23 ft
- Peak clearance height : 6.4 m / 21 ft
- Roll up door : 4.6 x 4.7 (m) / 15 x 15.4 (ft) (The front and rear doors are the same size).
- Shoulder wall clearance height : 2.8 m / 9 ft

**CONCRETE FOUNDATION SIZE SEE BELOW FIGURE.**

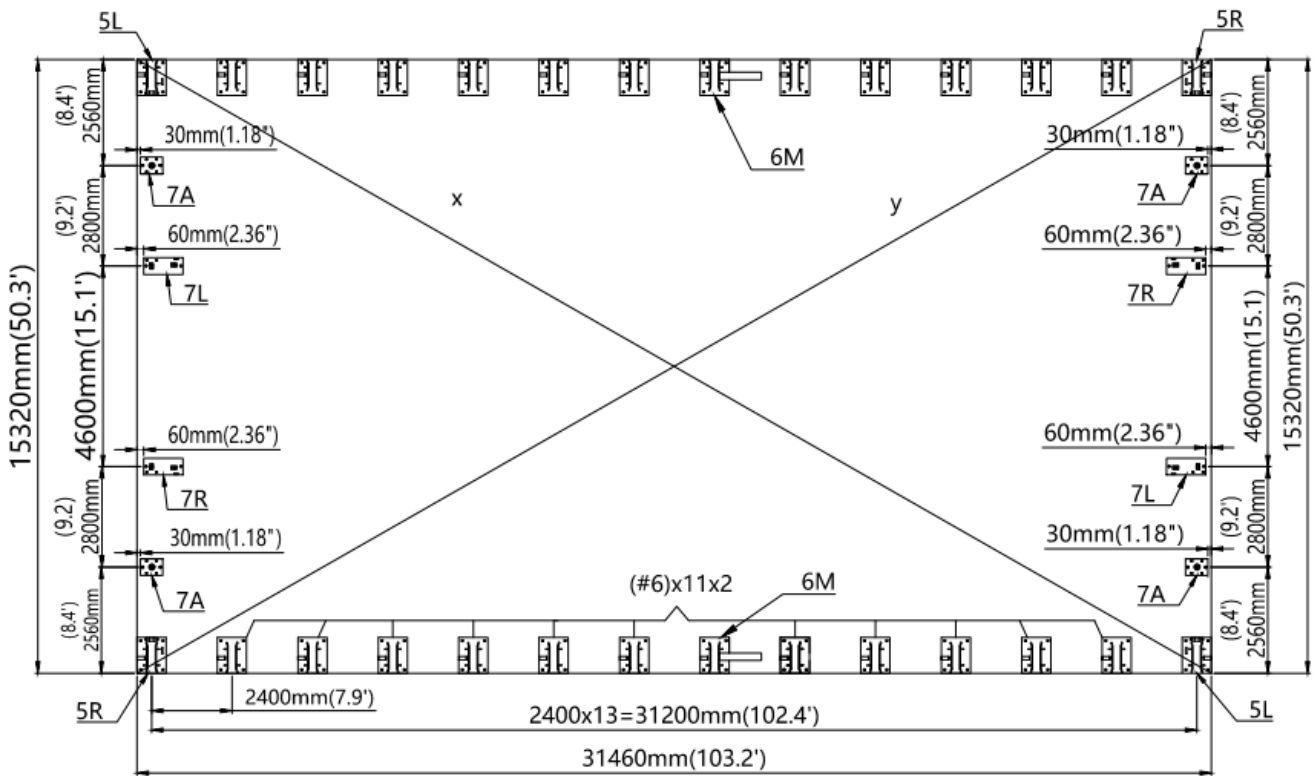

**PRIOR TO ASSEMBLY**

Please go through the whole instruction manual completely. It is very important to follow your local safety regulations and industry standards during installation. Regulations may include but are not limited to:

- Safety helmets, protective eyewear, and clothing
- Safety harnesses for all elevated workers
- Proper ladder, cage, and safety operation

Check all components and parts before installation. All parts are marked with a part number, please refer to the parts list to ensure you have all parts.

Choose a day with low or no wind to install, it is hard to assemble with heavy wind. Do not make any alterations to the structure. Do not hang any weight on the frame during installation, including parts. We are not responsible for any damages or injuries caused by inappropriate installation, unauthorized modifications or extreme weather.

This building is not intended for human occupancy.







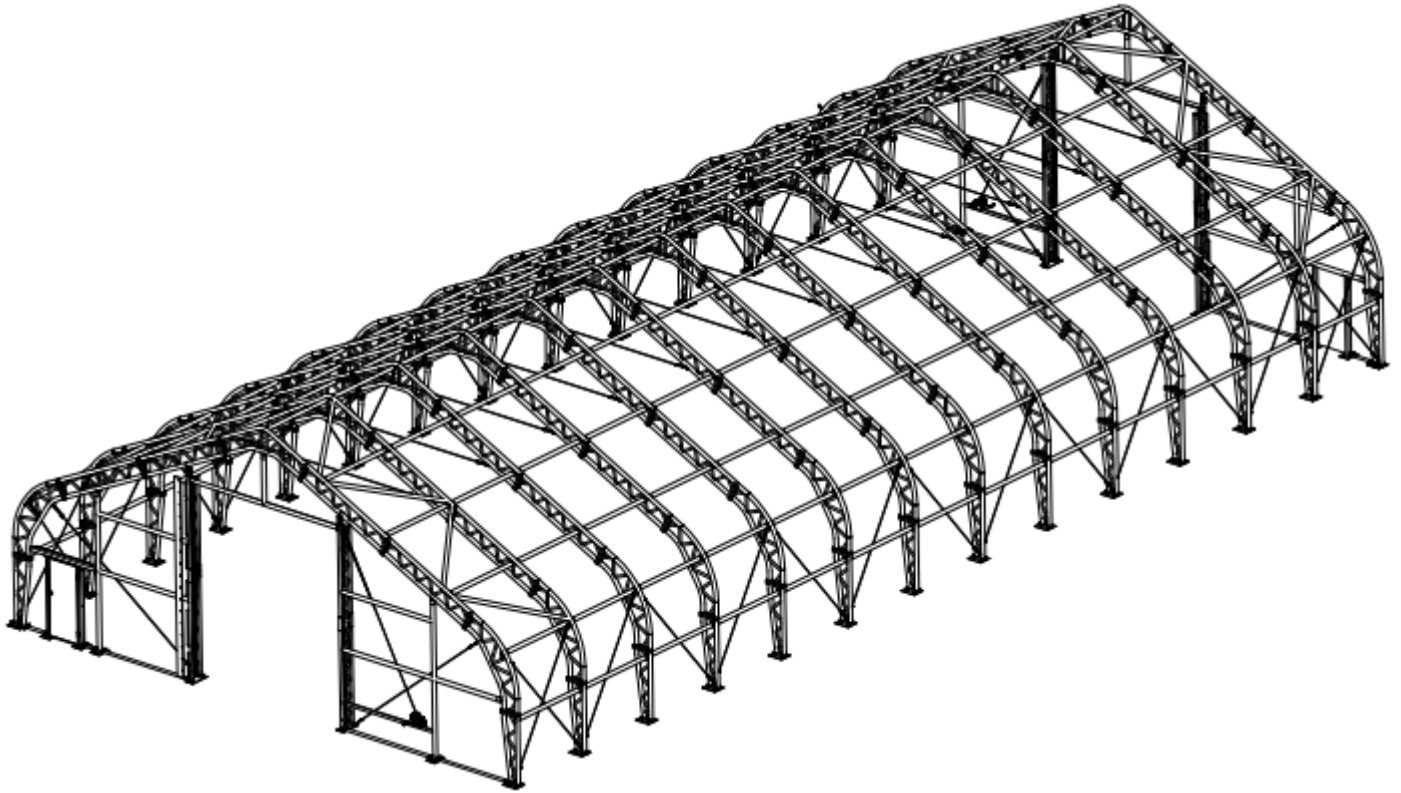

It is recommended to use heavy duty duct tapes to tape the tube connection joint spots to protect the cover from damage and worn. It will help to extend the cover life span.

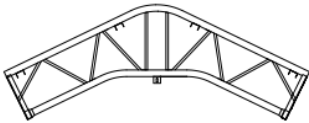

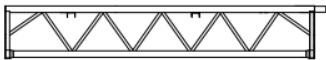
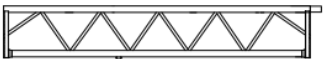
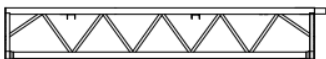

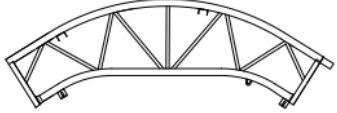

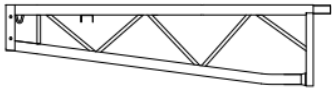
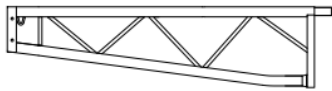

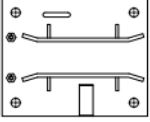

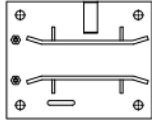
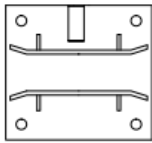
Check the parts list below to make sure all parts are received prior to assembly.

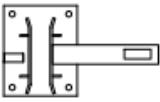

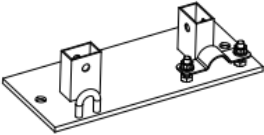
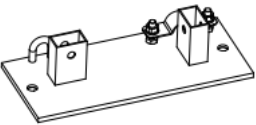
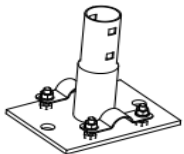





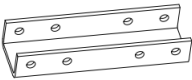

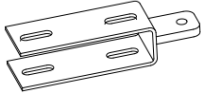



**FRAME STRUCTURE DIAGRAM.**







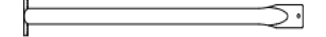

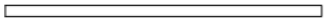
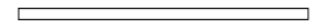

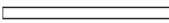











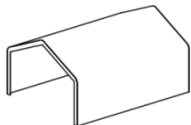

**TMG-DT50100-PRO PART LIST**

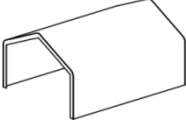
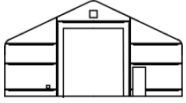
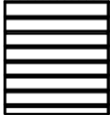
PARTS CODE	GRAPHICAL	DESCRIPTION	LENGTH	QTY	BOX
1A		Peak arch tube (for front and rear truss)	L2646mm	2	A
1		Peak arch tube (for 6 middle trusses )	L2646mm	12	A
2A		Upper rafter tube (for front and rear truss)	L2855mm	4	C
2		Upper rafter tube (for middle truss)	L2855mm	24	B/C
3A		Lower rafter tube (for front and rear truss)	L2855mm	4	C
3		Lower rafter tube (for middle truss)	L2855mm	24	C
4A		Shoulder tube (front and rear truss)	L2613mm	4	B
4		Shoulder tube (for middle truss)	L2613mm	24	D/E
5A		Sidewall tube (front and rear truss)	L1895mm	4	D
5		Sidewall tube (for middle truss)	L1895mm	24	E
5B		Roof purl in (horizontal tube)	φ58xL2440mm	143	B
5C		Front and rear span tube	φ58xL2890mm	16	A
5L		Base plate for front and rear truss left corners	W260xL320mm	2	A

5R		Base plate for front and rear truss right corners	W260xL320mm	2	A
6		Base plates for middle truss	W260xL280mm	22	A
6A		Ratchets	3T	106	A
6M		Base plates for middle truss (group 8 truss)	W280xL570mm	2	A
6C		Clip		6	A
7L		Left base plate of front and rear door frame	W150xL350mm	2	A
7R		Right base plate of front and rear door frame	W150xL350mm	2	A
7A		Front and rear door left and right column base plate	W150xL200mm	4	A
8		Side door right tube	W200xL2070mm	2	A
8A		Side door left tube	W200xL2070mm	2	A
8B		Side door	L2005xW925mm	2	D
8C		Pressing plate	W20xL1000mm	2	A
8D		Pressing plate	W20xL2000mm	12	A
9B		Front and rear vertical door rail connection plate	W69xL240mm	8	A

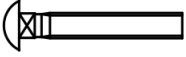
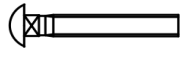
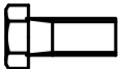
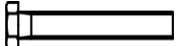
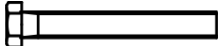
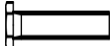
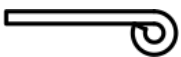
9C		Front and rear vertical door rail end plate (floatable to keep door rail straight)	W60xL218mm	4	A
9L		Front and rear vertical door rail (left side upper part)	W250xL2376mm	2	A
9R		Front and rear vertical door rail (right side upper part)	W250xL2376mm	2	A
10L		Front and rear vertical door rail (left side lower part)	W250xL2660mm	2	A
10R		Front and rear vertical door rail (right side lower part)	W250xL2660mm	2	A
10A		Right lower vertical tubes for front and rear trusses	φ58xL2198mm	2	A
10B		Left and right upper vertical tubes for front and rear trusses	φ58xL1867mm	4	A
10		Left lower vertical tubes for front and rear trusses	φ58xL2198mm	2	A
11		Side door upper tube (front and rear)	W140xL2061mm	2	A
12		Front and rear door cross tubes (left and right)	W140xL2756mm	8	A
12A		Front and rear door cross tubes (left and right)	W140xL2062mm	2	A
13		Front and rear door cross beam (left)	W140xL2304mm	2	A
13A		Front and rear door cross beam (right)	W140xL2284mm	2	A
13B		Front and rear door center vertical supporting rod for cross beam	W140xL1280mm	2	A
14		Front and rear door hand winch crossing tube	W140xL2761mm	2	A
15		Front and rear fabric panel tension tubes	φ32xL2700mm	4	A
15A		Front and rear fabric panel tension tubes	φ32xL2200mm	2	A

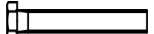
15B		Front and rear fabric panel tension tubes	φ32xL750mm	2	A
15C		Front and rear fabric panel tension tubes	φ32xL470mm	2	A
16		Front and rear roll up door dropping tubes (to connect #16A)	φ32xL2346mm	14	A
16A		Front and rear roll up door dropping tubes (to connect #16)	φ32xL2342mm	14	A
16B		Middle truss crossing steel tension cables	φ6xL5900mm	16	A
16C		Sidewall frame steel tension cables	φ6xL4700mm	30	A
17		Tarp cover tension tubes on both sides	φ32xL1993mm	30	C
17A		Tarp cover tension tubes on both sides	φ32xL1450mm	2	C
17B		Tarp cover tension tubes on both sides	φ32xL970mm	2	C
18		Pipe clamps for front and rear vertical tubes to connect to truss frame	φ58mm	28	A
19		Tension tube end water plug	φ32mm	26	A
20		Roll up door hand winch	1200LB	2	A
21		Wire rope for front and rear door hand winch	φ4xL16m	2	A
22		Tie down straps (for #6A and front and rear arches)	W38x800mm	106	A
23		Scratch resistant tape	L10m	5	A
24		Roof fabric tarp cover		1	E

24A		Roof fabric tarp cover		1	E
25		Front and rear truss fabric tarp panel		2	A
25A		Front and rear roll up door fabric tarp panel		2	A
26		Plastic hose (in grooves at both ends of #24)	φ25xL4000m	24	D
26A		Connector (for connection #26)	φ25	20	A
27		Tension ropes (tie to front and back doors)	φ32xL300m	1	A
28		Self locking bolt and nuts	M10x80mm	154	A
29		Self locking bolt and nuts	M8x70mm	16	A
30		Hex bolt and nuts	M12x30mm	560	A
31		Hex bolt and nuts	M10x90mm	92	A
31A		Hex bolt and nuts	M10x100mm	8	A
32		Hex bolt and nuts	M10x50mm	34	A
33		Front and rear fabric tarp secure pin	φ6x200mm	4	A
34		Expansion bolts φ16	φ16x150mm	136	A
35		Cable connection plate	L91mm	18	A
36		Hex bolt and nuts	M10x60mm	12	A
37		Tapping screw	#12x25mm	104	A



**STEP 1 : BASEPLATE POSITIONING AND INSTALLATION.**

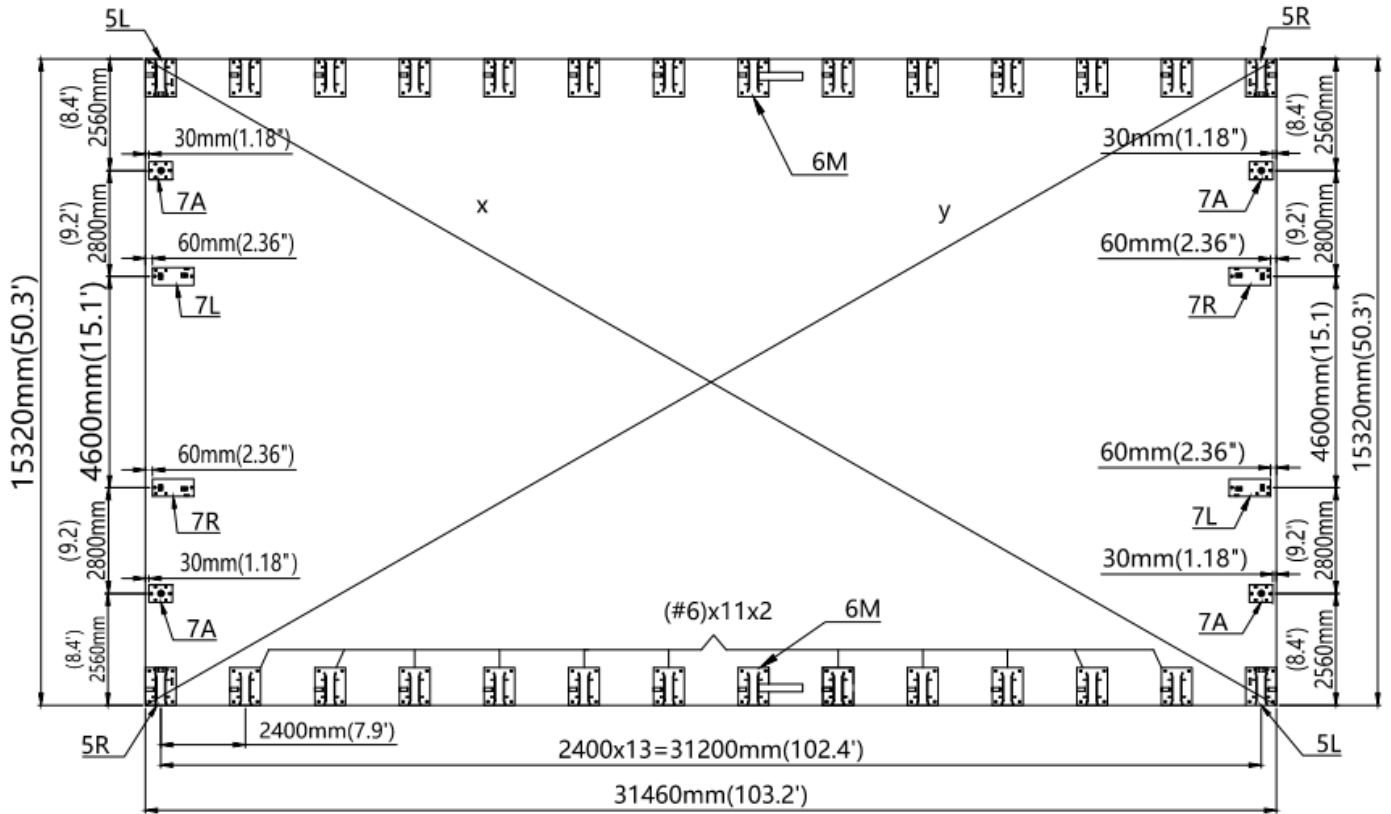





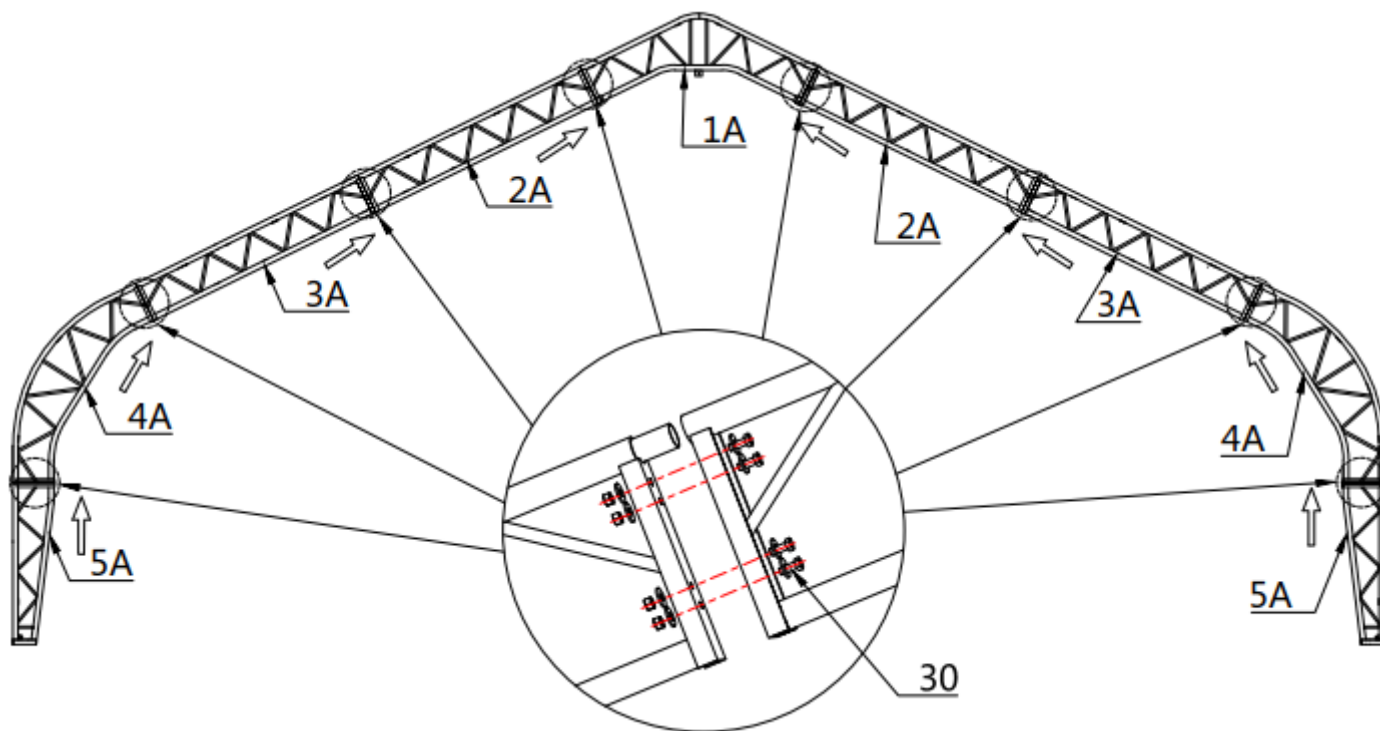

PARTS CODE	PART	QTY
5L		2
5R		2
6		22
6M		2

PARTS CODE	PART	QTY
7L		2
7R		2
7A		4
34		128

**STEP 2 : INSTALLATION OF FRONT AND REAR 2 GROUP TRUSSES.**



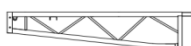



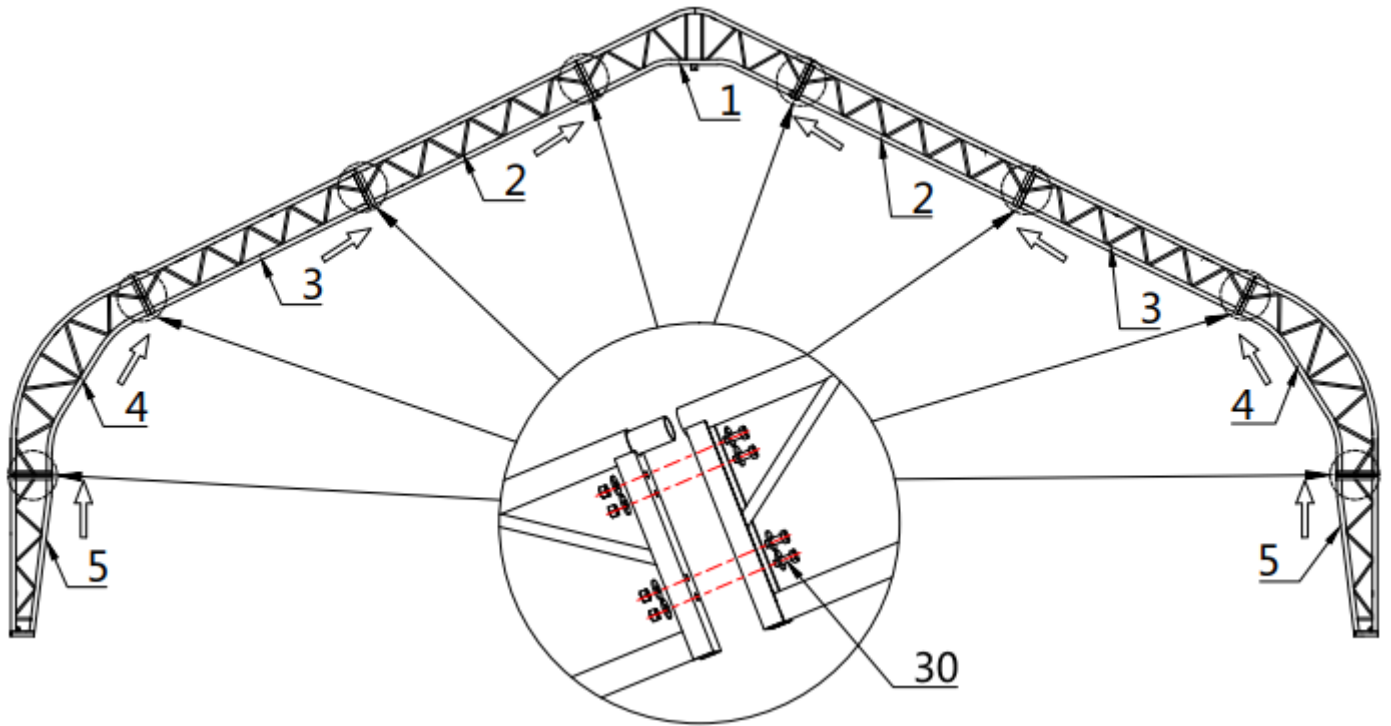

PARTS CODE	PART	QTY
1A		1x2
2A		2x2
3A		2x2
4A		2x2

PARTS CODE	PART	QTY
5A		2x2
30		32x2

**STEP 3 : INSTALLATION OF MIDDLE 12 GROUP TRUSS.**



PARTS CODE	PART	QTY
1		1x12
2		2x12
3		2x12
4		2x12

PARTS CODE	PART	QTY
5		2x12
30		32x12

**STEP 4 : WRAP (#23) AROUND THE SHARP POINTS OF THE JOINT TO AVOID FRICTION BETWEEN THE FABRIC AND THE INTERFACE.**

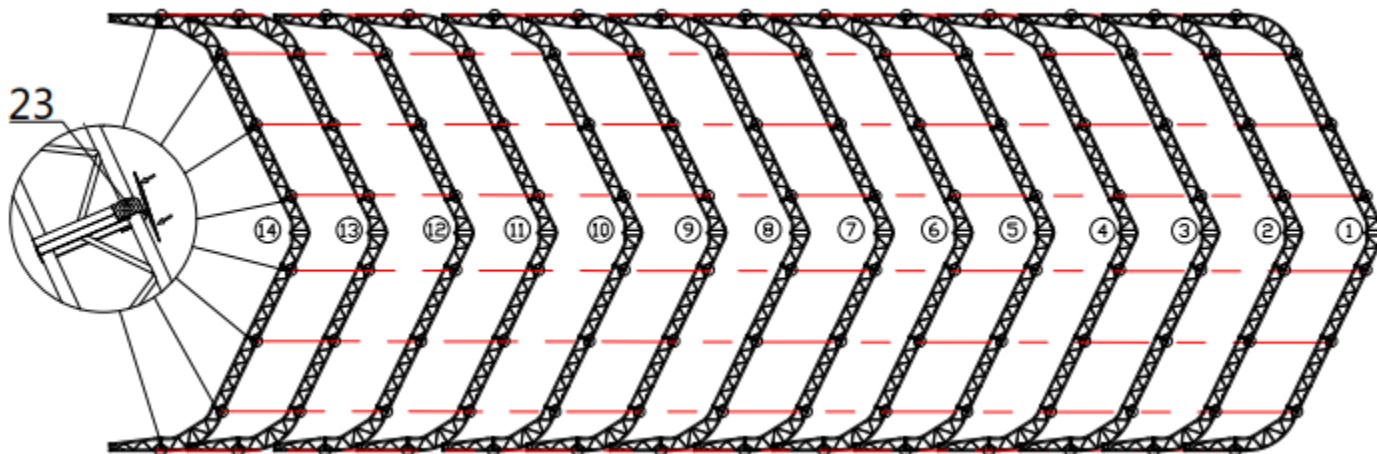

PARTS CODE	PART	QTY
23		5

**STEP 5 : PUT UP THE FRONT TRUSS (IT IS SUGGESTED TO USE CRANE FOR HOISTING).**

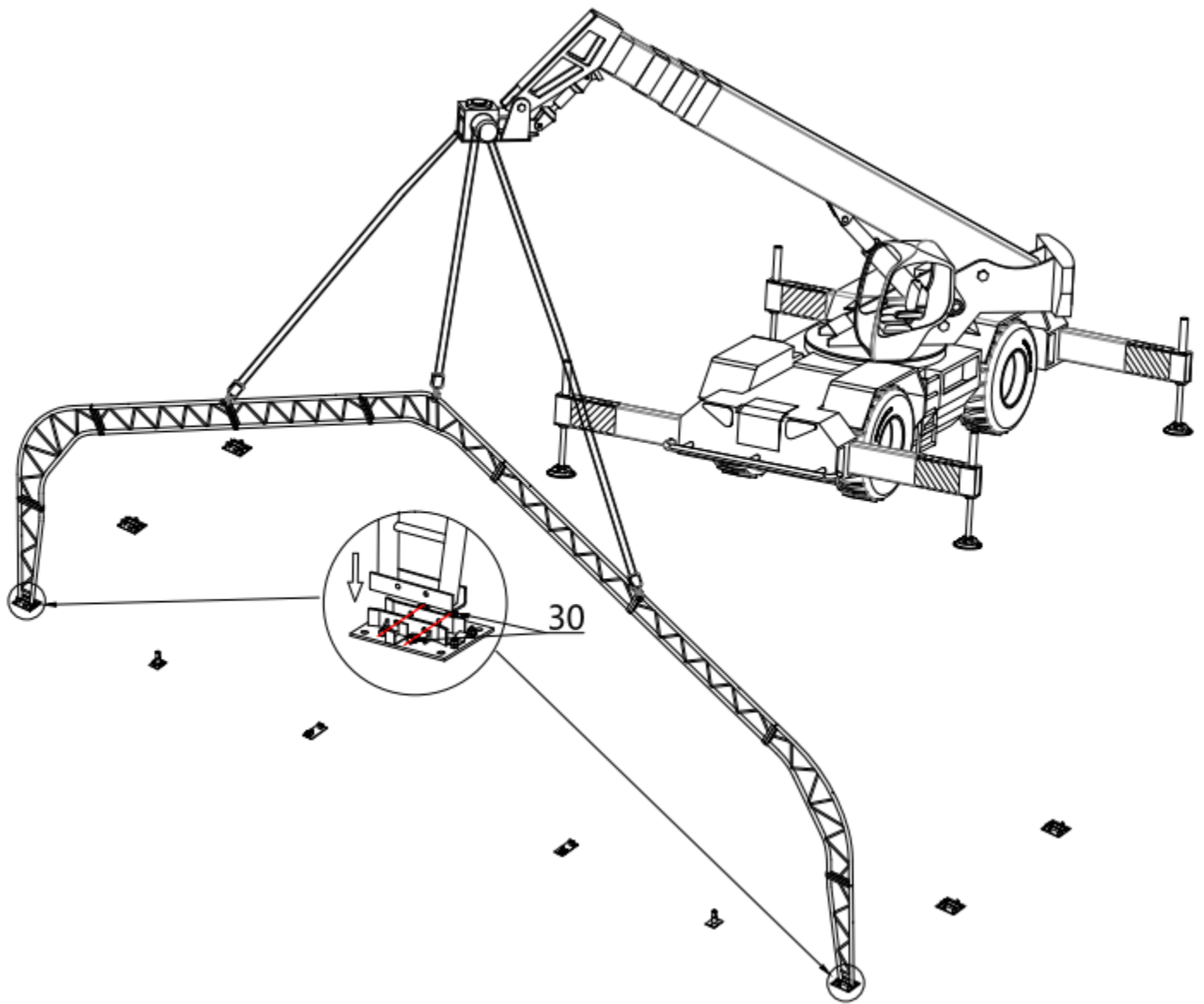

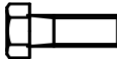
PARTS CODE	PART	QTY
30		8

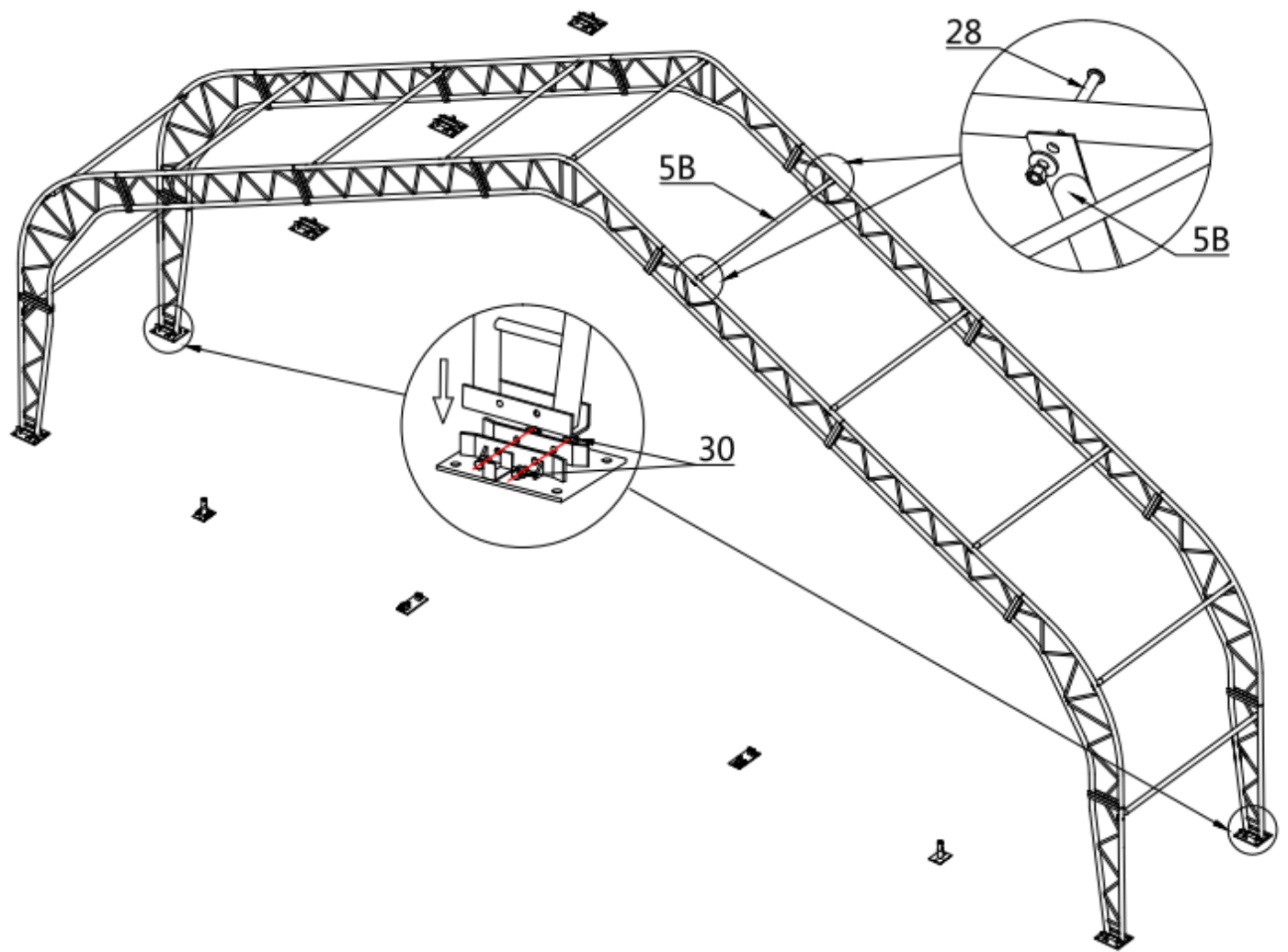

STEP 6 : PUT UP THE 2ND TRUSS, AND CONNECT ALL PURLINS (#5B) BETWEEN 1ST AND 2ND.

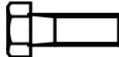
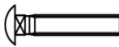

PARTS CODE	PART	QTY
5B		11
30		8
28		22

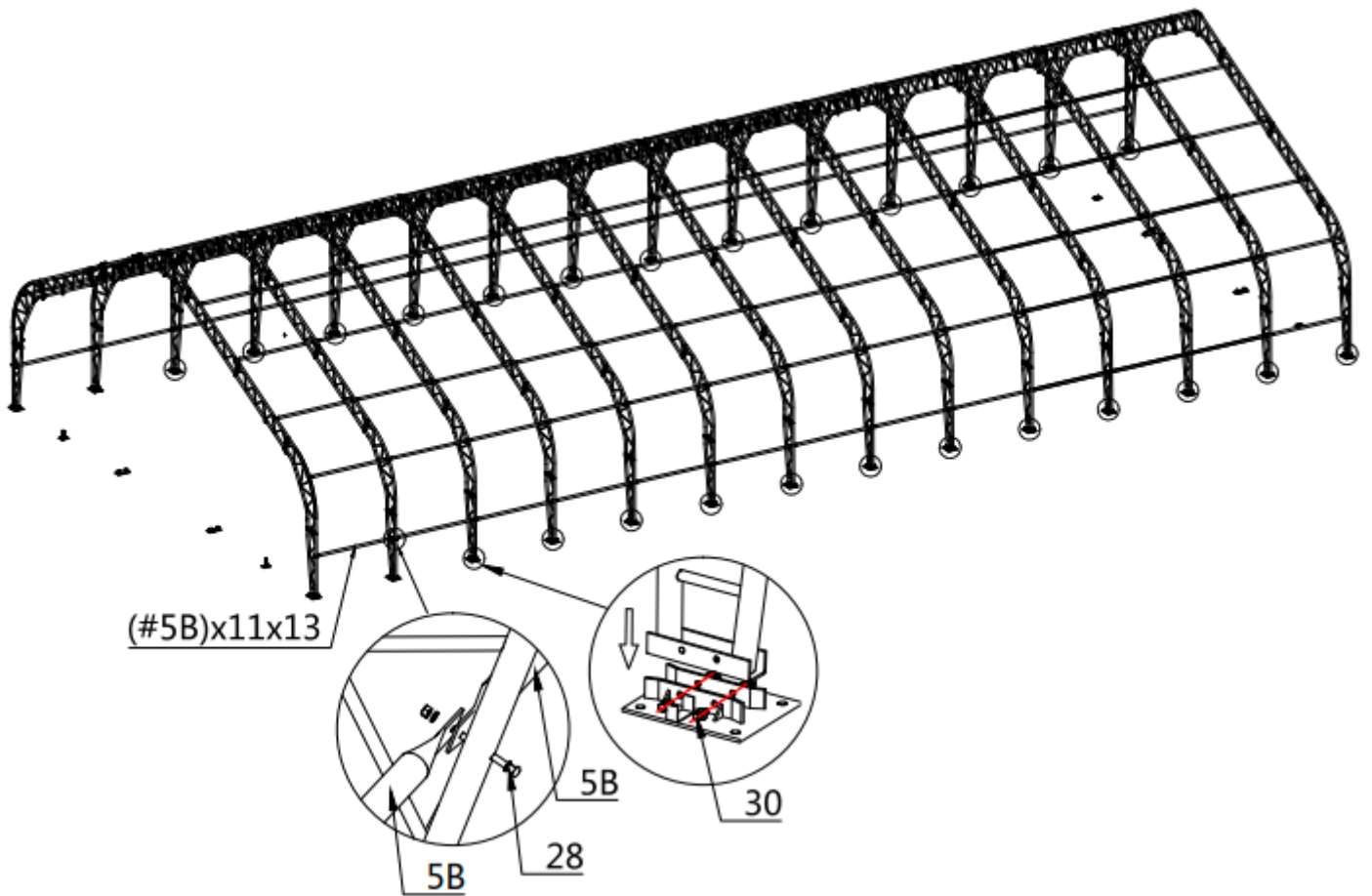

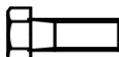
STEP 7 : REPEAT ABOVE STEP TO PUT UP ALL OTHER TRUSSES, AND CONNECT ALL PURLINS.

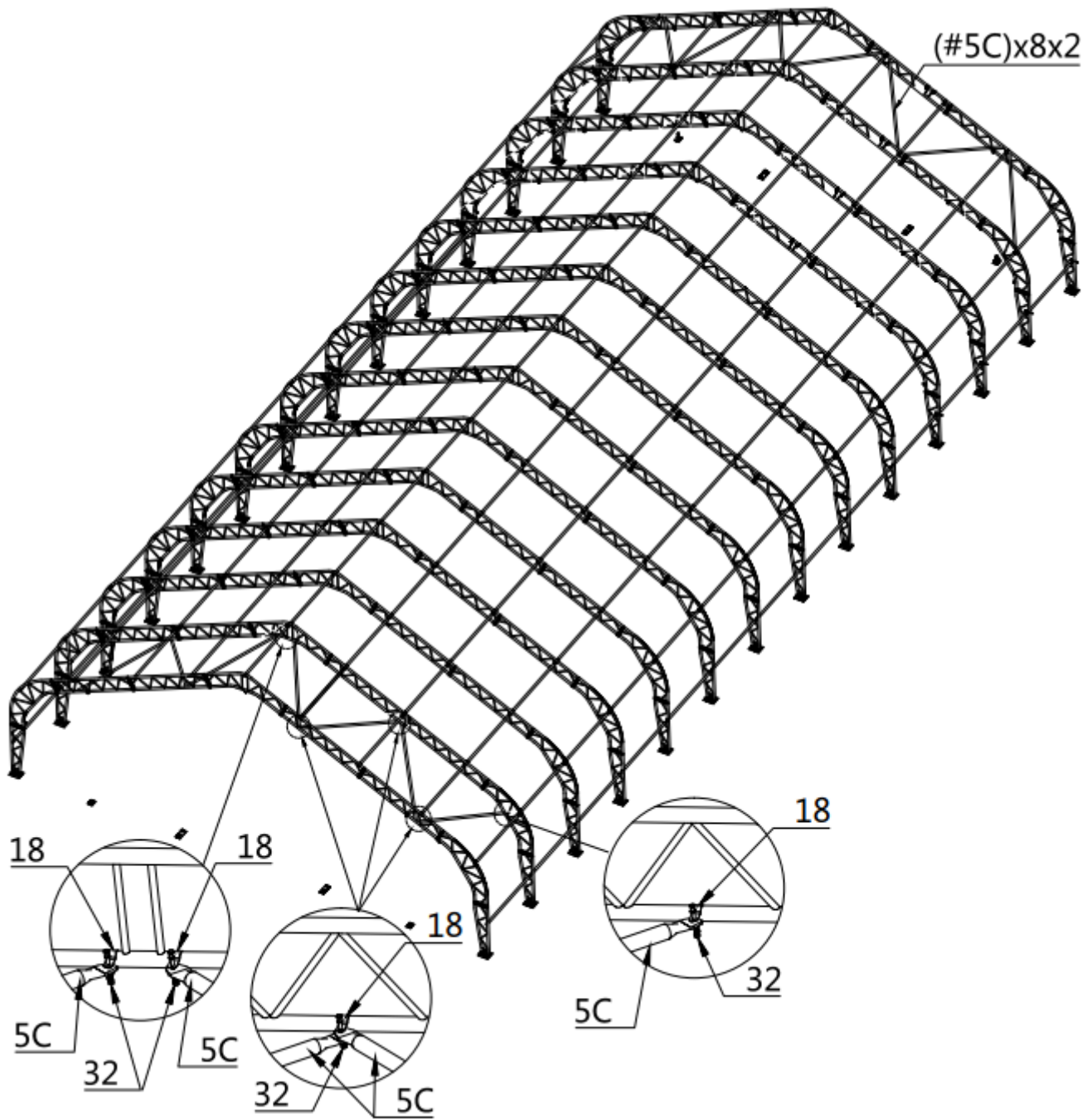

PARTS CODE	PART	QTY
5B		132
30		96
28		132

STEP 8 : INSTALLATION OF DIAGONAL PURLINS (THE FRONT AND REAR MOUNTING METHODS ARE THE SAME).

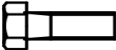

PARTS CODE	PART	QTY
5C		16
18		20
32		20



**STEP 9 : TENSION CABLE INSTALLATION, ALL CABLES ARE DIAGONALLY INSTALLED ON EACH.**

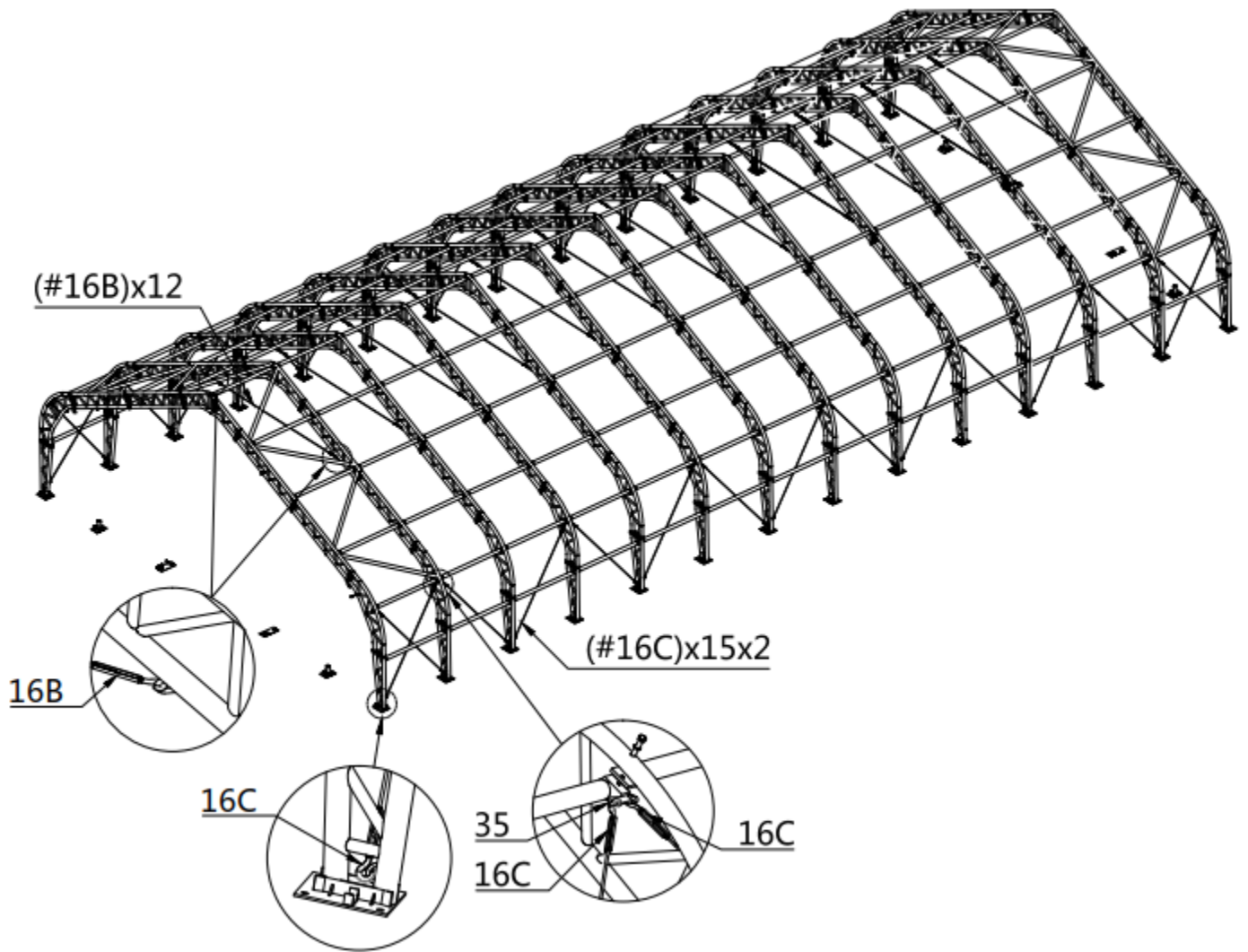

PARTS CODE	PART	QTY
16B		12
16C		30
35		18

**STEP 10 : DOOR COLUMN INSTALLATION (THE FRONT AND REAR MOUNTING METHODS ARE THE SAME).**

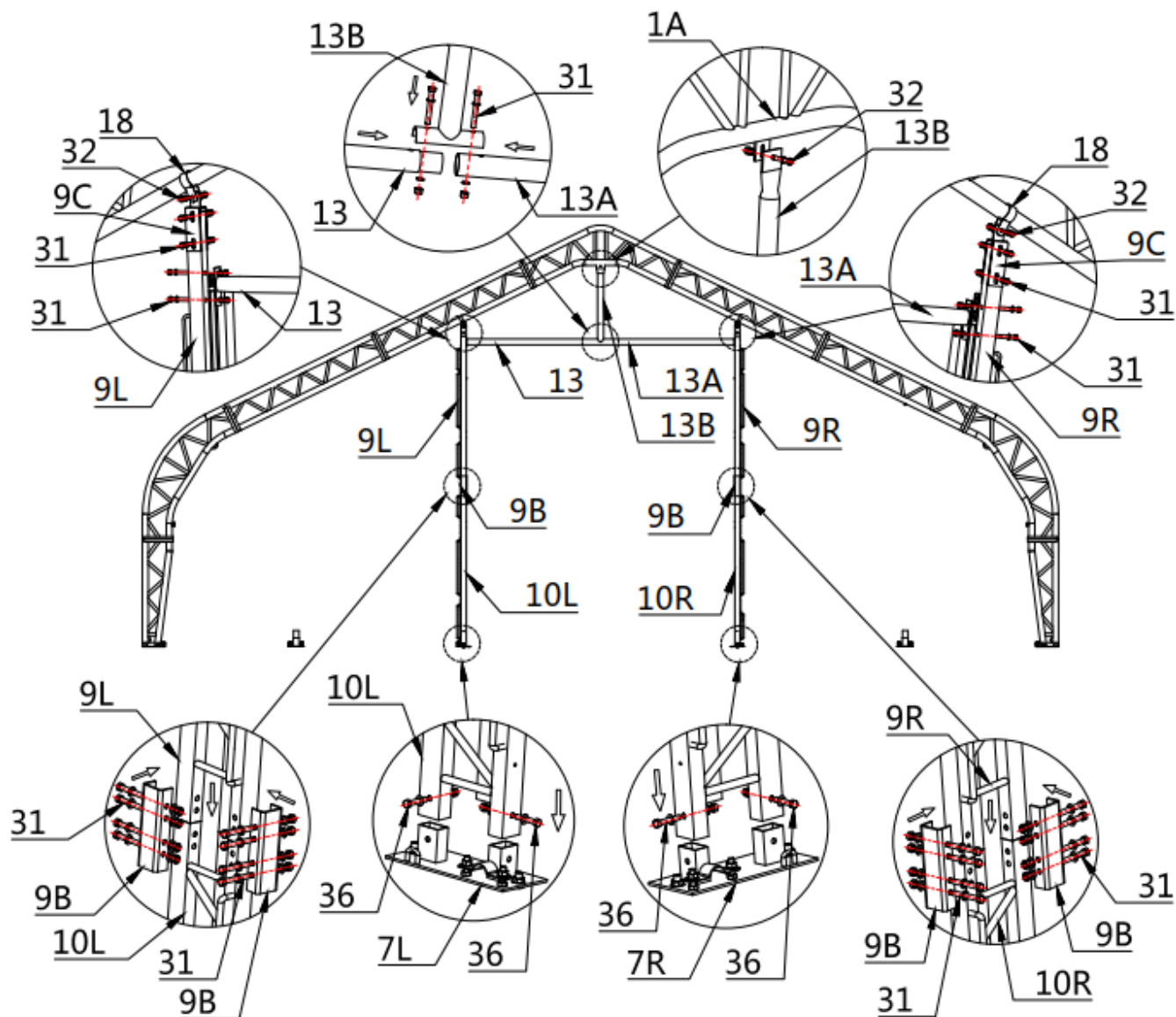

PARTS CODE	PART	QTY
9L		1
9R		1
9B		4
9C		2
10L		1

PARTS CODE	PART	QTY
10R		1
13		1
13A		1
13B		1
18		2

PARTS CODE	PART	QTY
31		26
32		3
36		4

STEP 11 :

1. DOOR SUPPORT PIPE INSTALLATION (THE FRONT AND REAR MOUNTING METHODS ARE THE SAME).

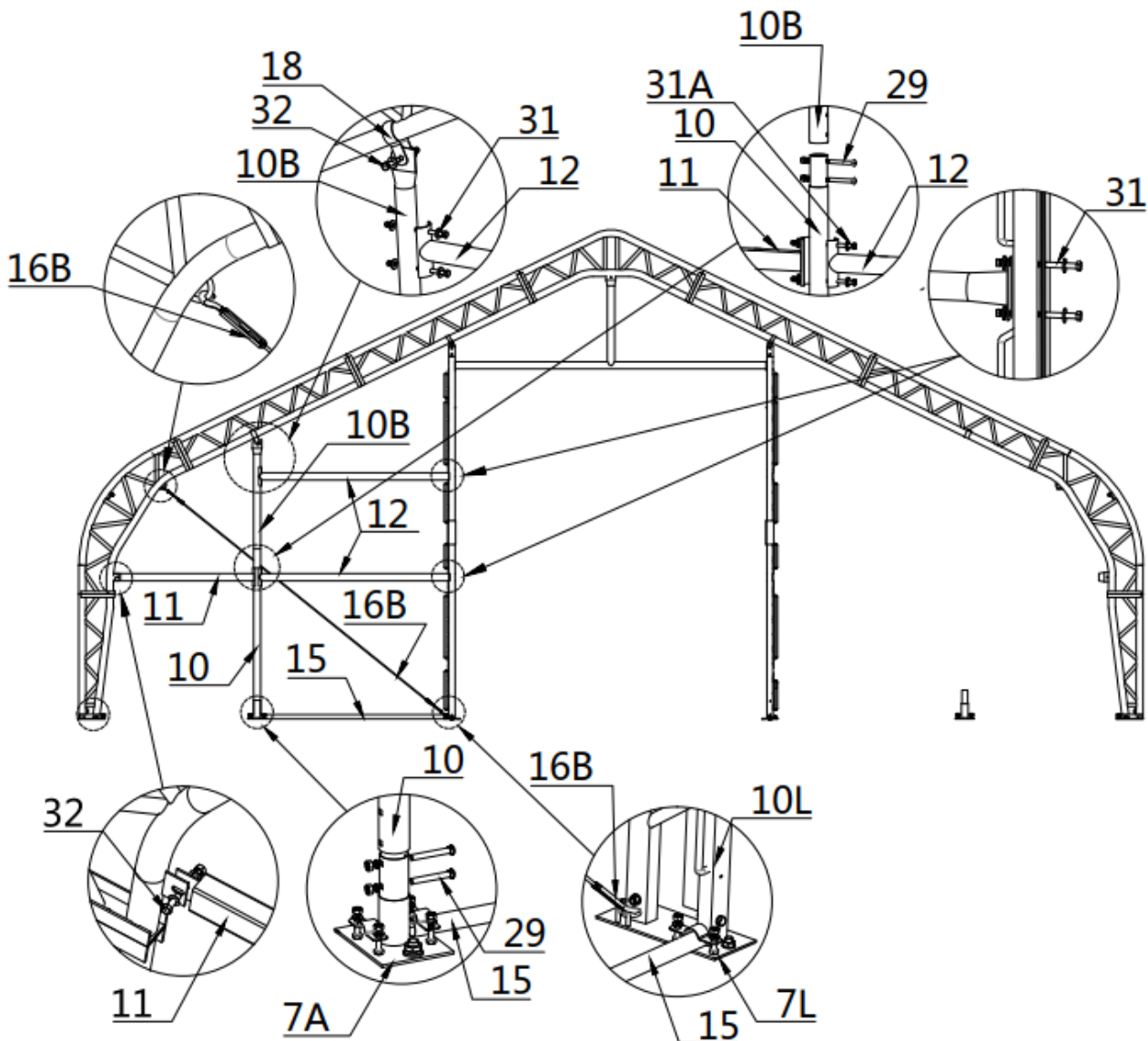

PARTS CODE	PART	QTY
10		1
10B		1
11		1
12		2

PARTS CODE	PART	QTY
15		1
16B		1
18		1
29		4

PARTS CODE	PART	QTY
31		6
31A		2
32		2

STEP 11 :

2. DOOR SUPPORT PIPE INSTALLATION (THE FRONT AND REAR MOUNTING METHODS ARE THE SAME).

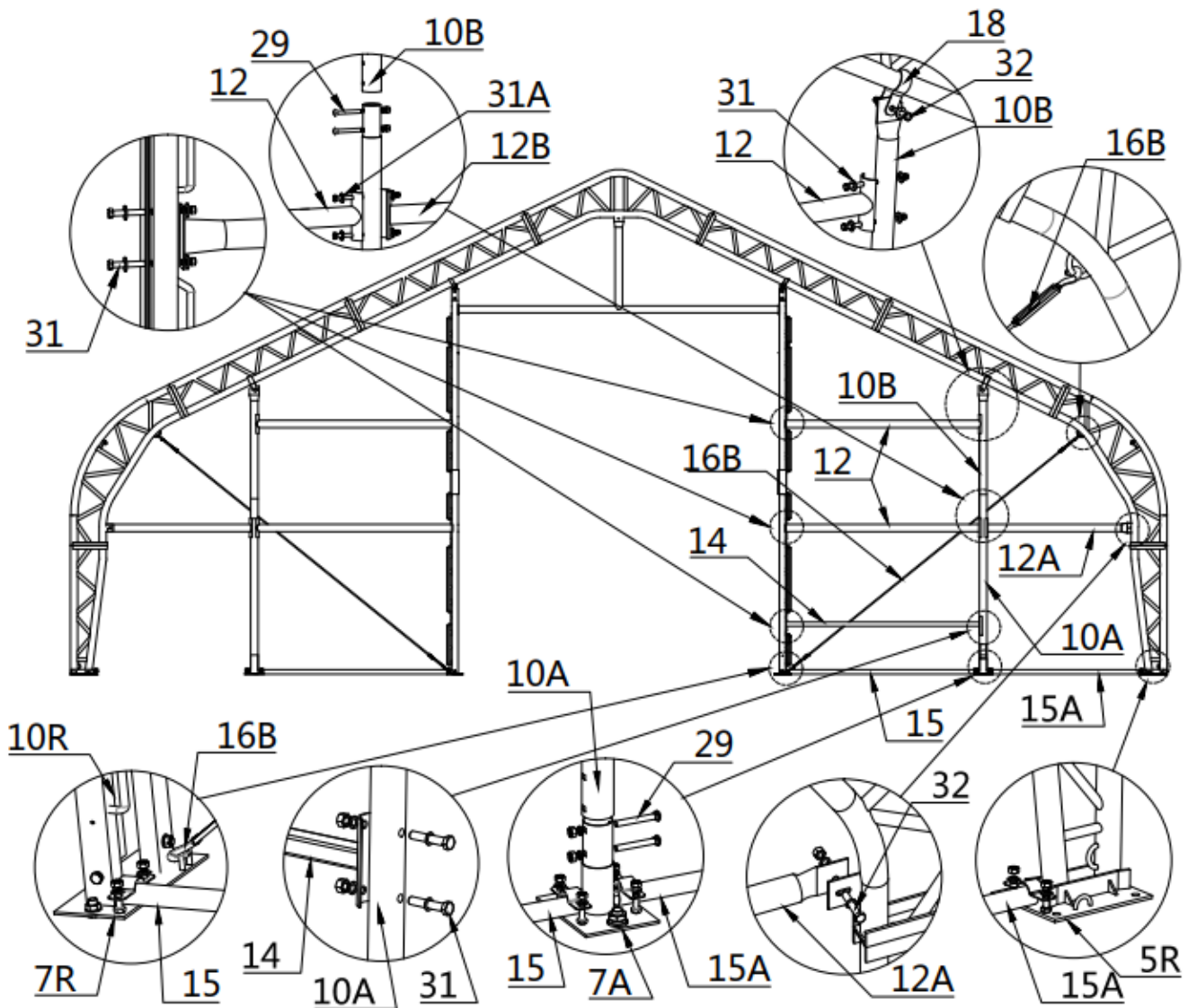



PARTS CODE	PART	QTY
10A		1
10B		1
12		2
12A		1

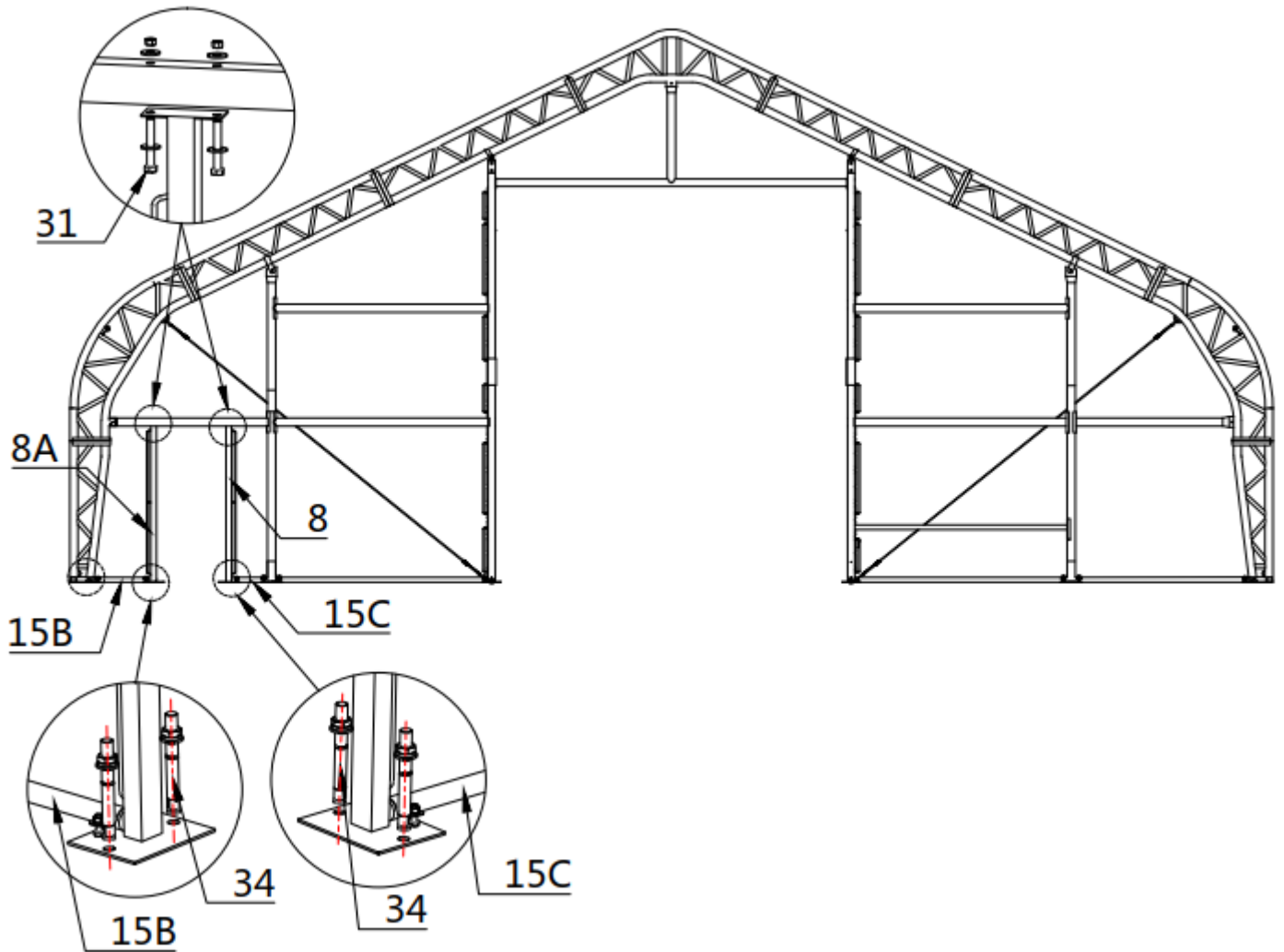

PARTS CODE	PART	QTY
14		1
15		1
15A		1
16B		1

PARTS CODE	PART	QTY
18		1
29		4
31		10
31A		2
32		2

**STEP 12 : INSTALLATION OF SIDE DOOR COLUMN (THE FRONT AND REAR MOUNTING METHODS ARE THE SAME).**

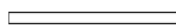



PARTS CODE	PART	QTY
8		1
8A		1
15B		1

PARTS CODE	PART	QTY
15C		1
31		4
34		4

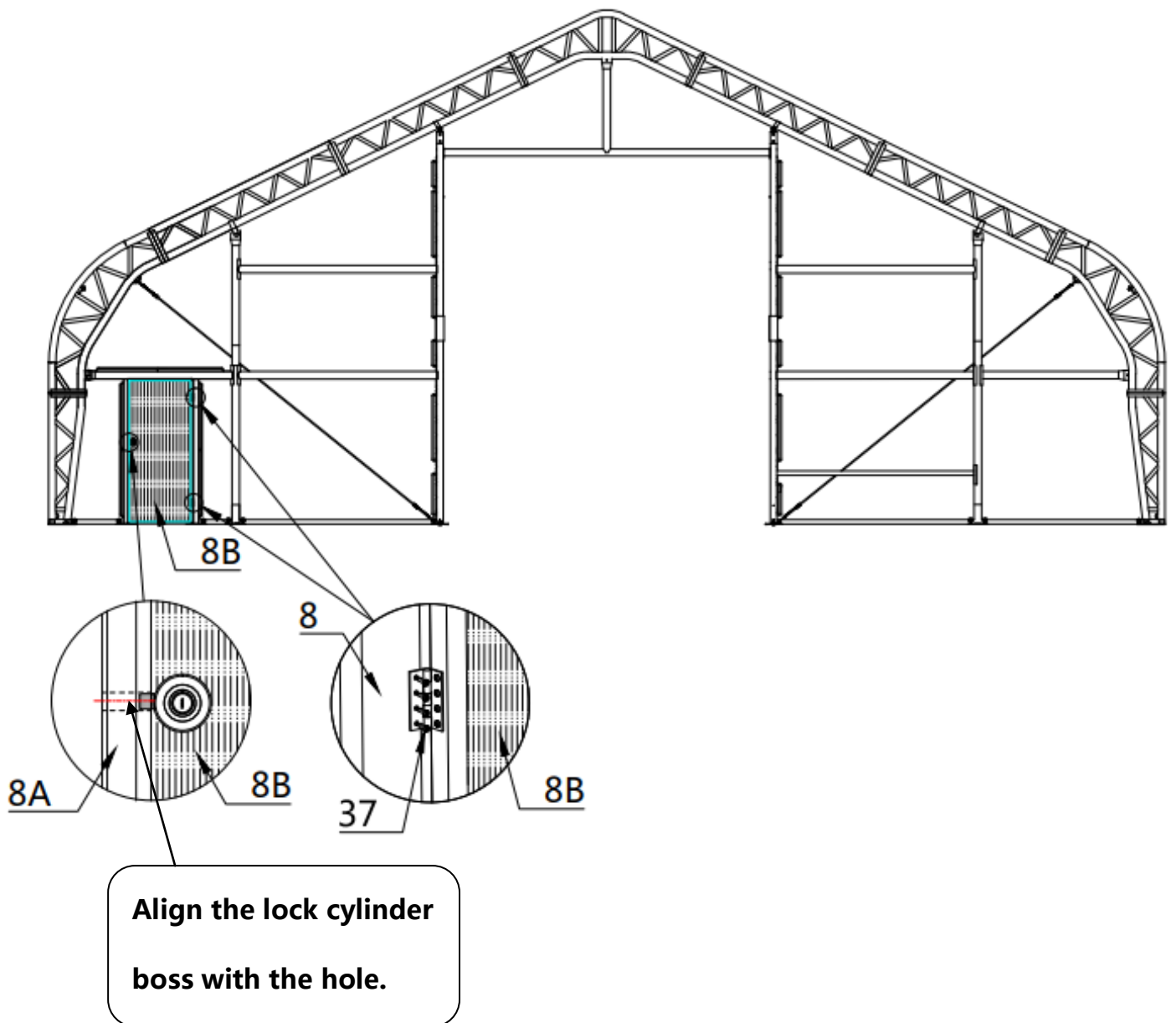
**STEP 13 : INSTALL THE SIDE DOOR (THE FRONT AND REAR MOUNTING METHODS ARE THE SAME).**



PARTS CODE	PART	QTY
8B		1
37		8

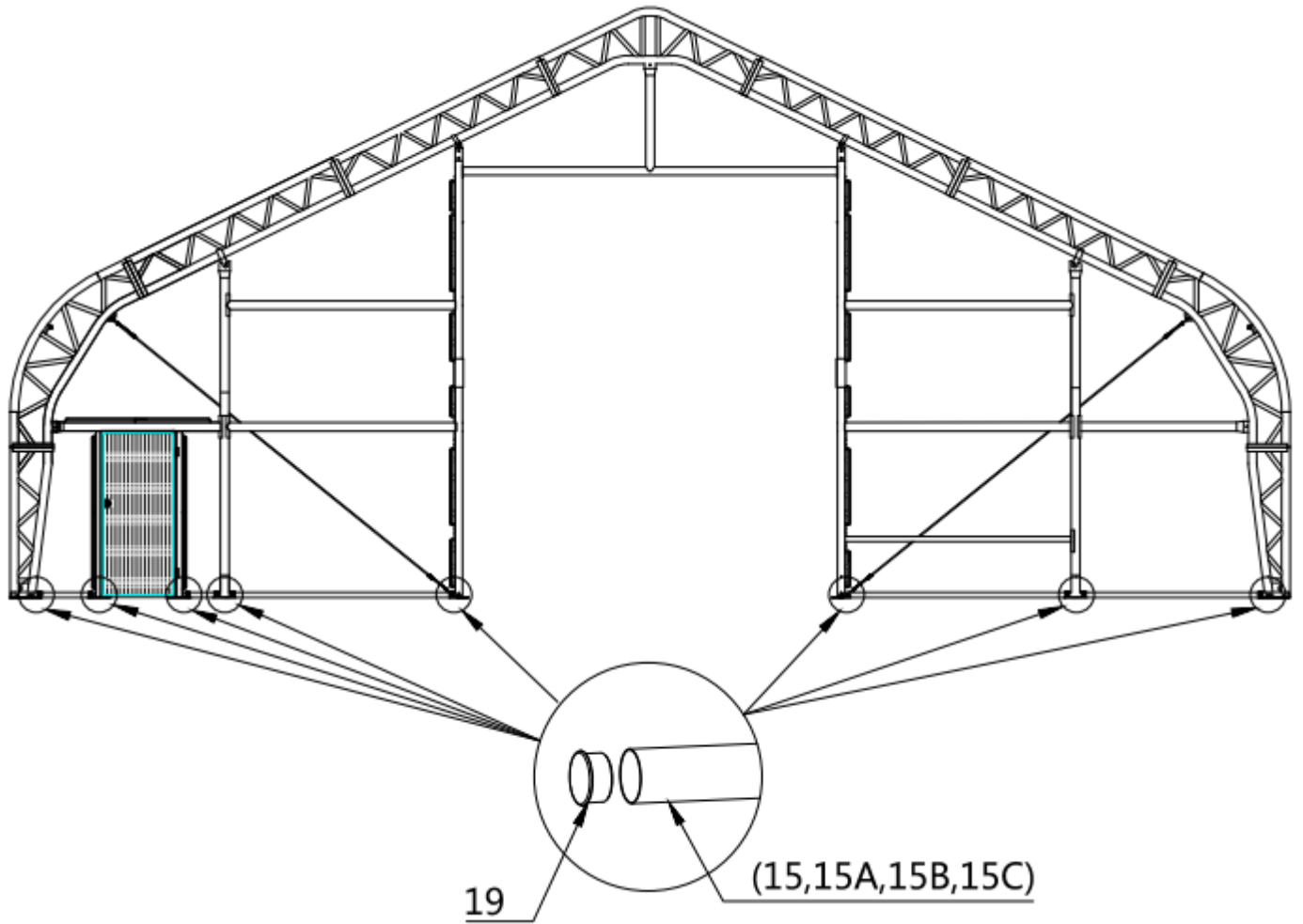

**STEP 14 : INSTALL THE WATERPROOF PLUG (THE FRONT AND REAR MOUNTING METHODS ARE THE SAME).**

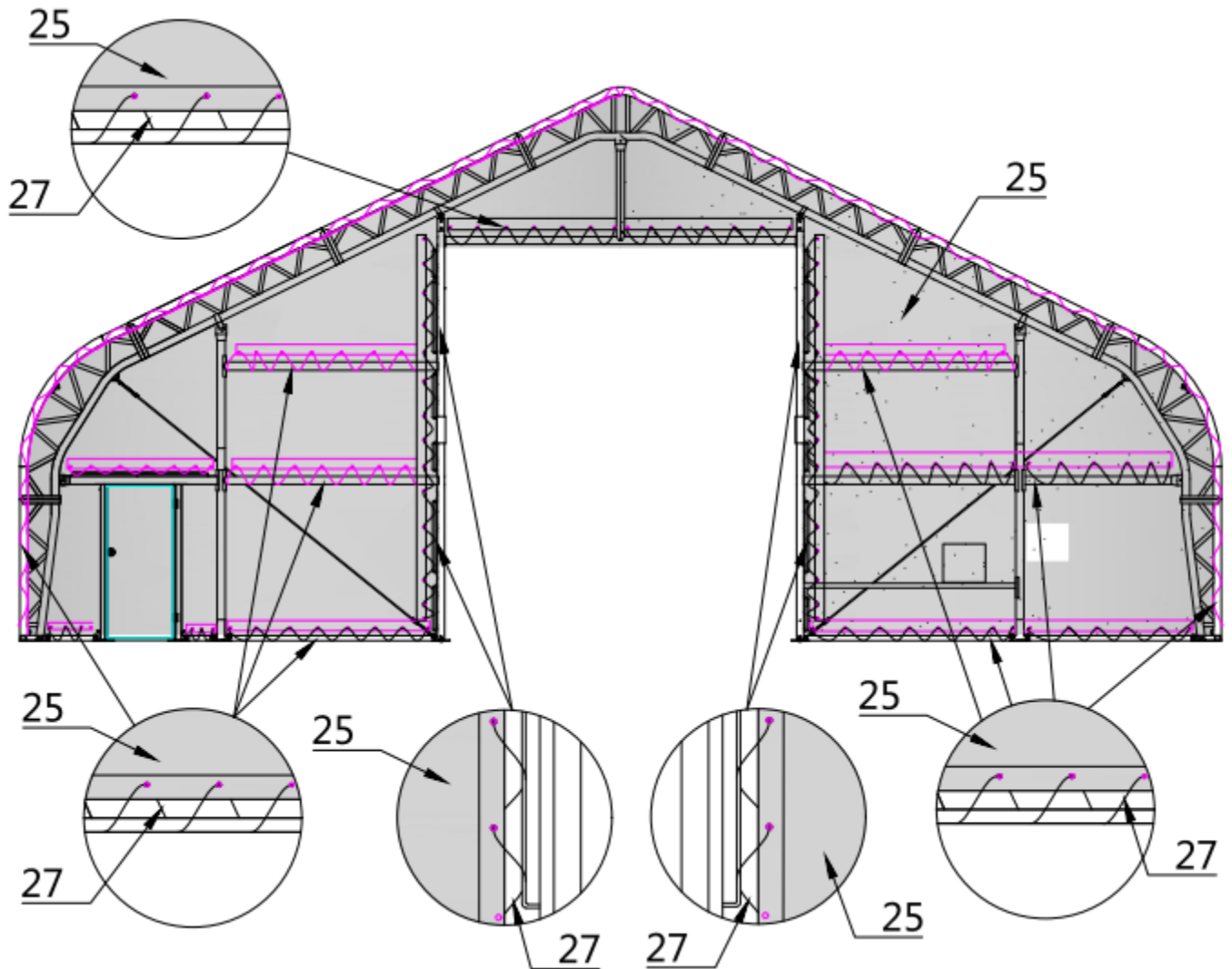

PARTS CODE	PART	QTY
19		10

**STEP 15 : INSTALL THE DOOR COVERING CLOTH (THE FRONT AND REAR MOUNTING METHODS ARE THE SAME).**

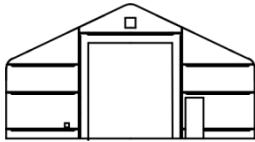



PARTS CODE	PART	QTY
25		1
27		1

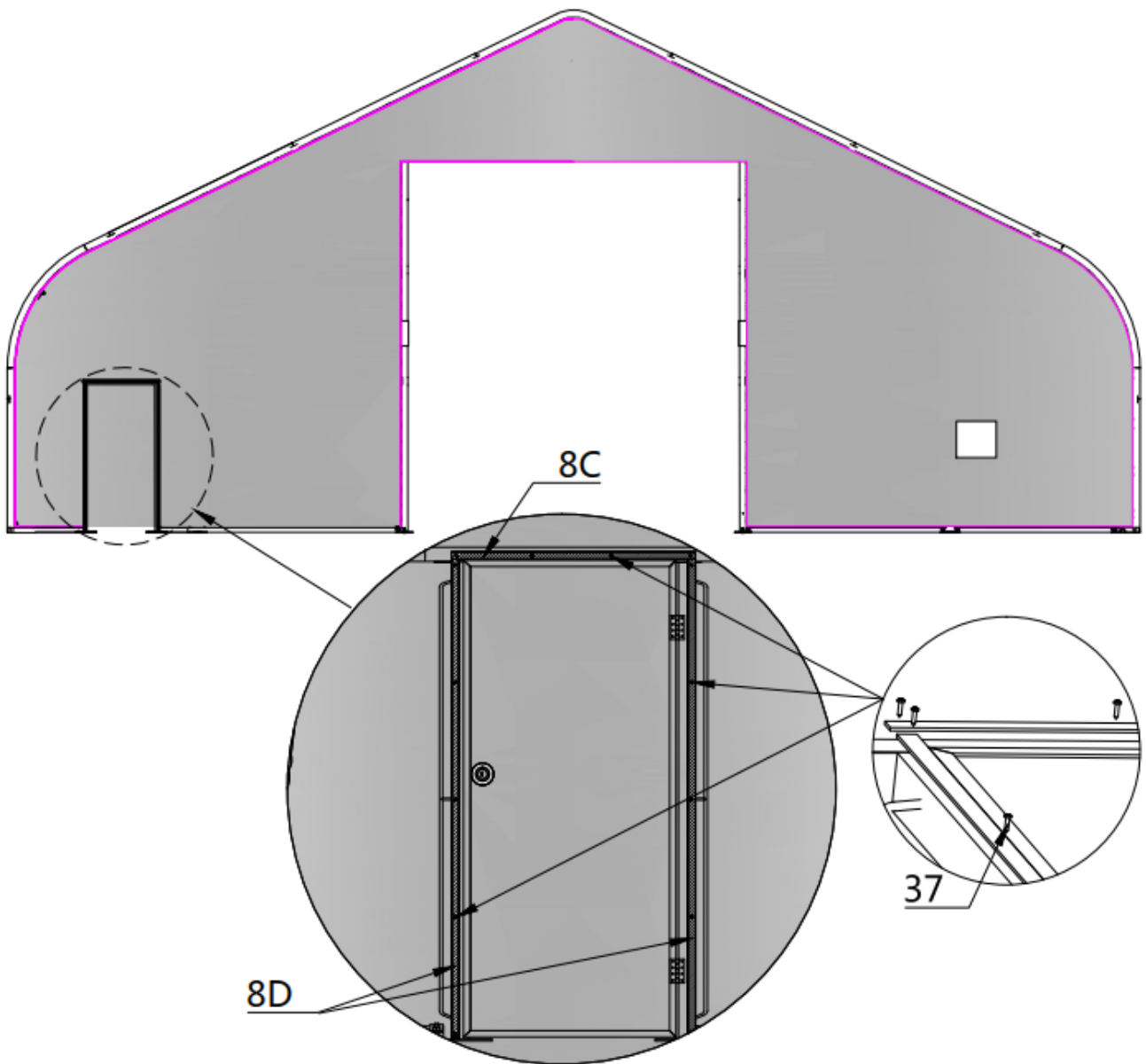

**STEP 16 : INSTALL THE SIDE DOOR METAL STRIP (THE FRONT AND REAR MOUNTING METHODS ARE THE SAME).**



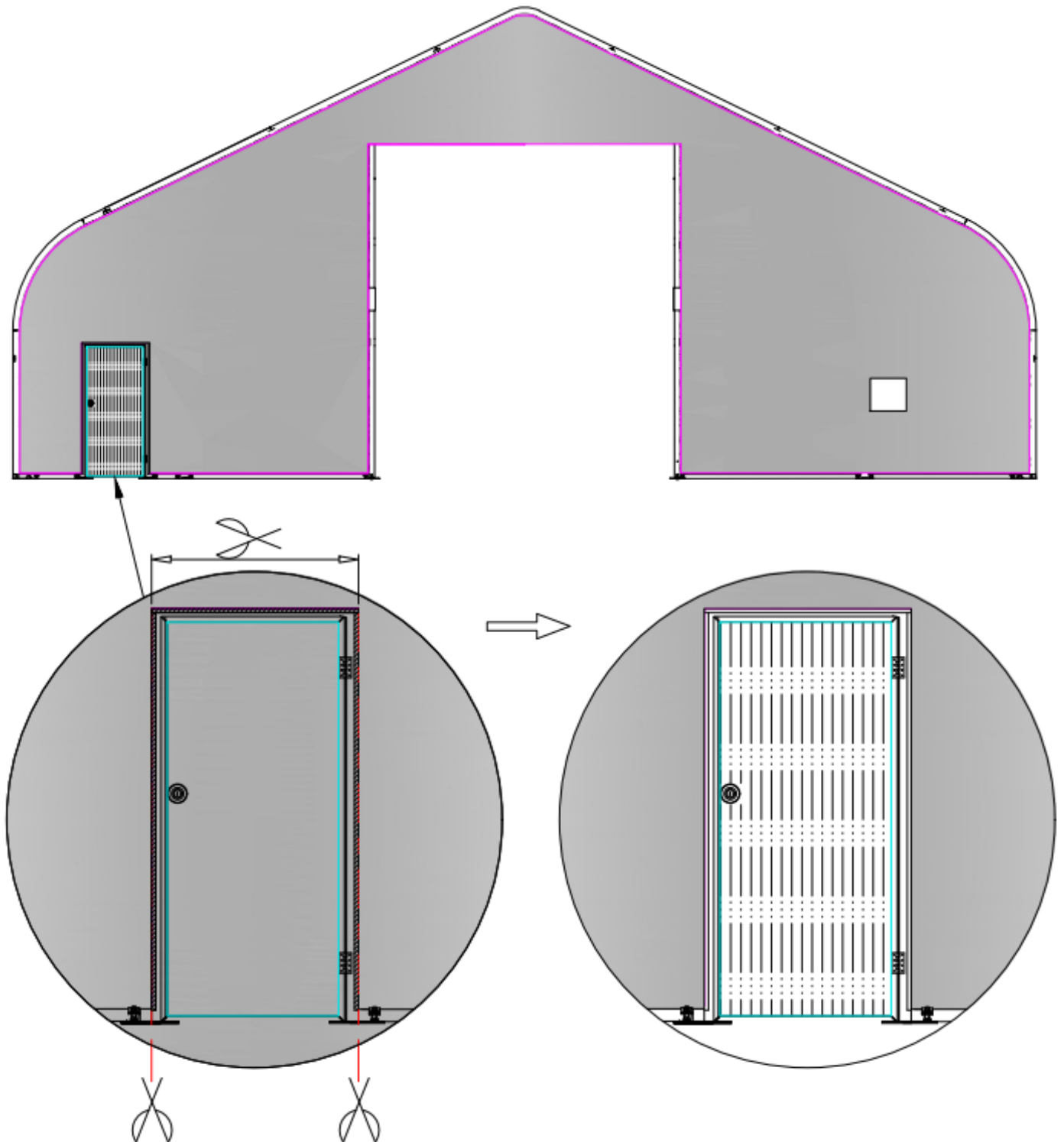

PARTS CODE	PART	QTY
8C		1
8D		2
37		20

**STEP 17 : CUT OPEN SIDE DOOR OPENINGS (THE FRONT AND REAR MOUNTING METHODS ARE THE SAME).**

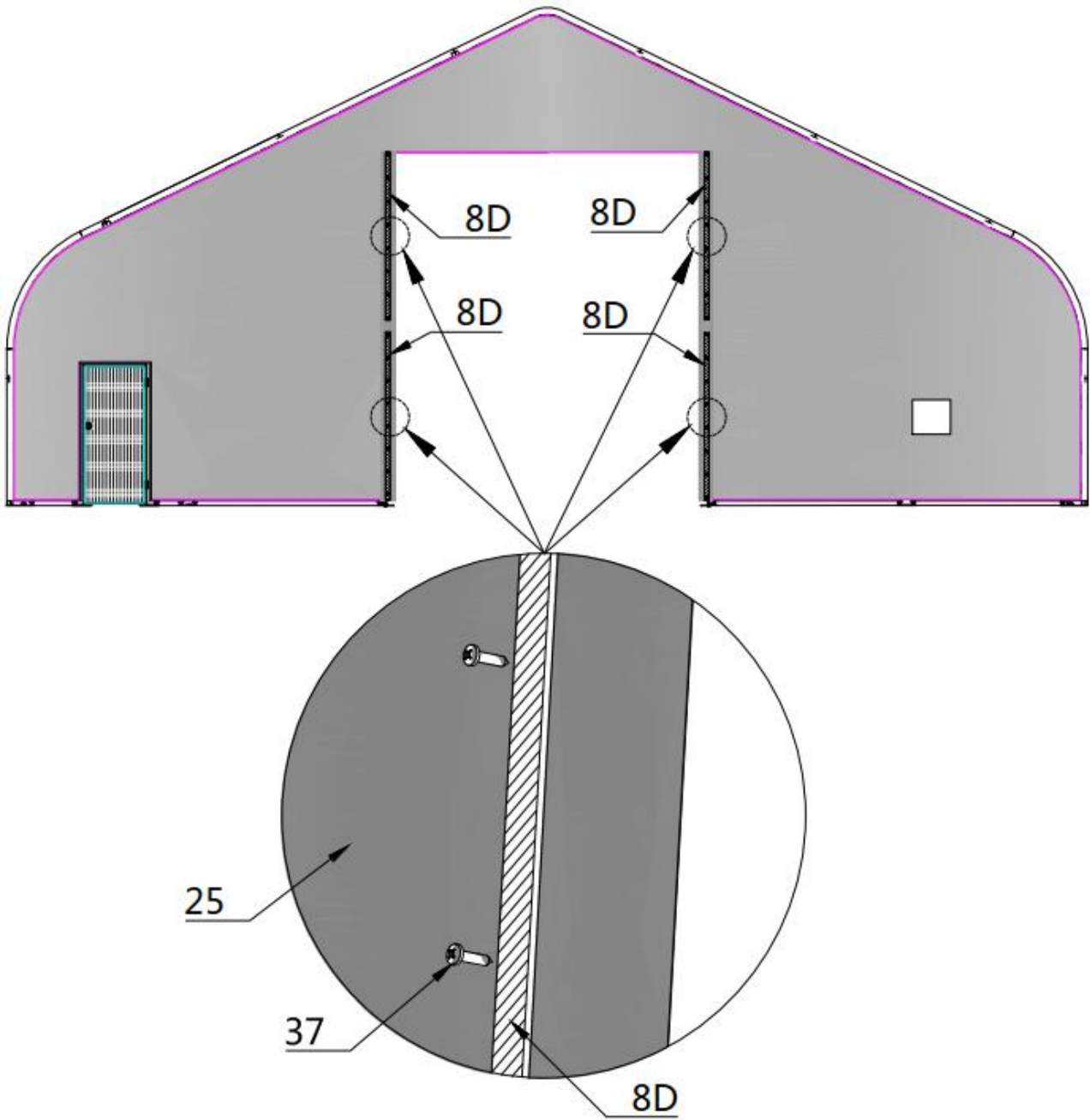

**STEP 18 : INSTALL THE FRONT DOOR METAL STRIP (THE FRONT AND REAR MOUNTING METHODS ARE THE SAME).**





PARTS CODE	PART	QTY
8D		4
37		32

STEP 19 :

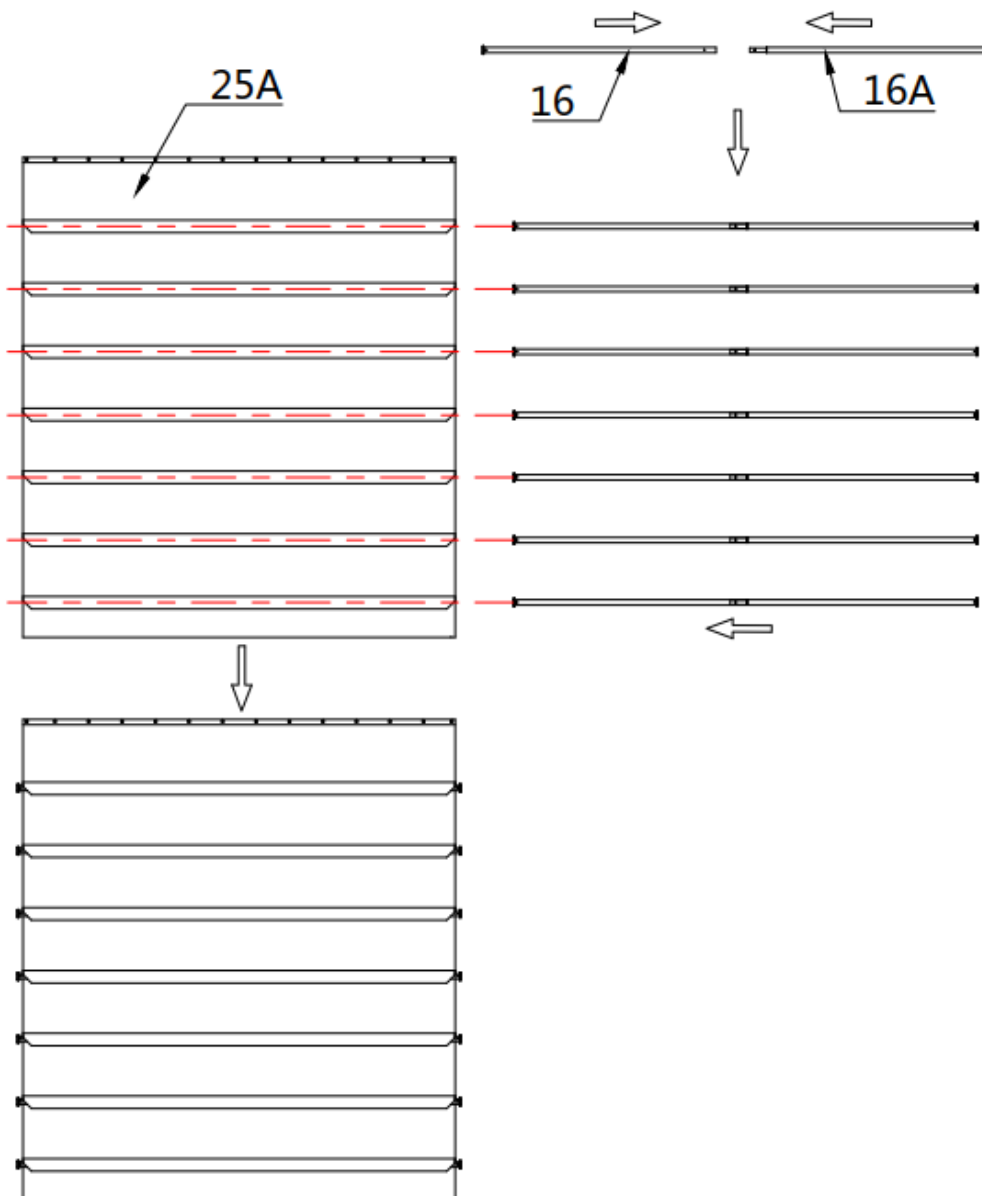
1. DOOR CURTAIN INSTALLATION (THE FRONT AND REAR MOUNTING METHODS ARE THE SAME).

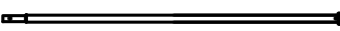



PARTS CODE	PART	QTY
16		7
16A		7
25A		1

STEP 19 :

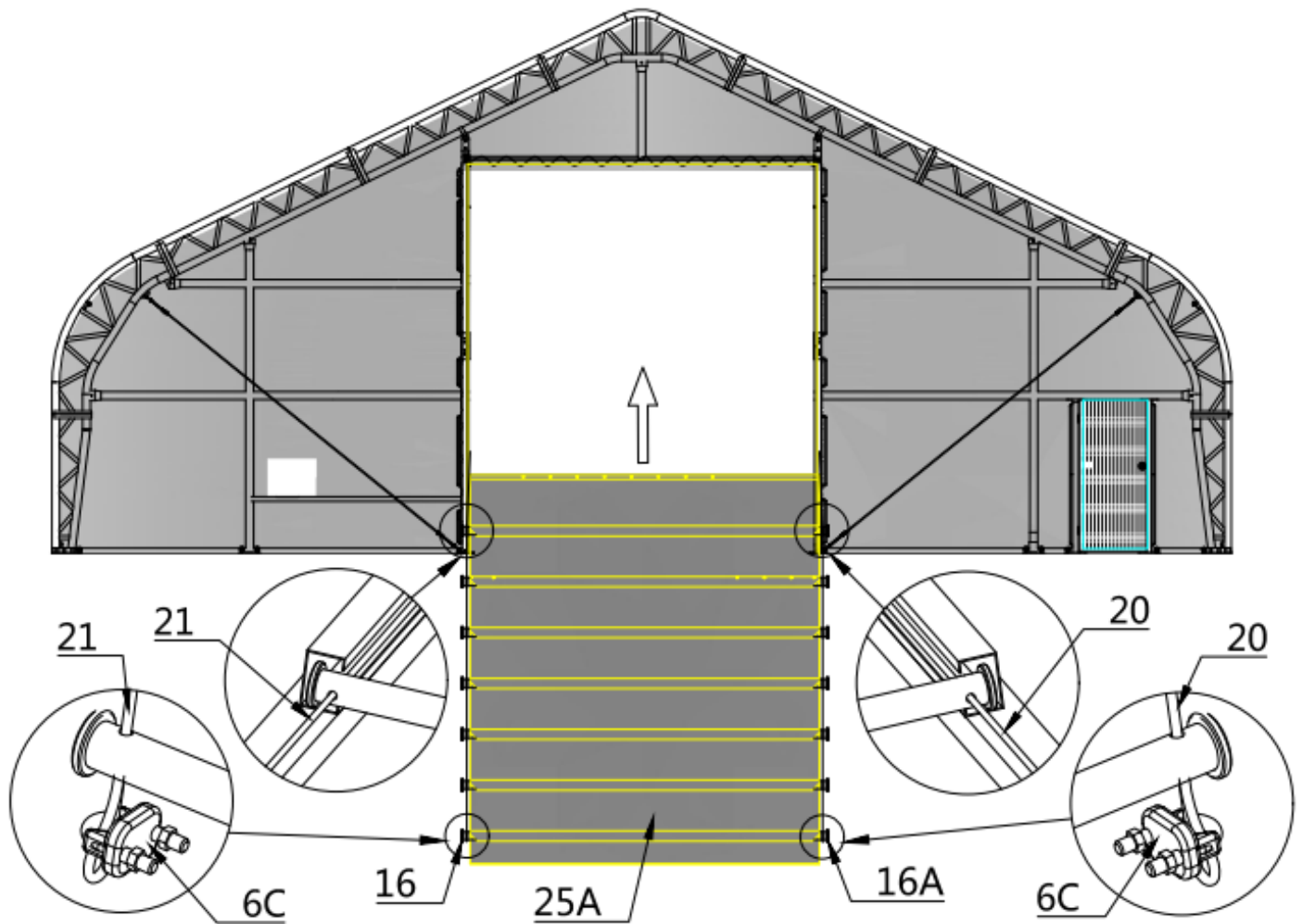
2. DOOR CURTAIN INSTALLATION (THE FRONT AND REAR MOUNTING METHODS ARE THE SAME).



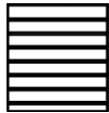

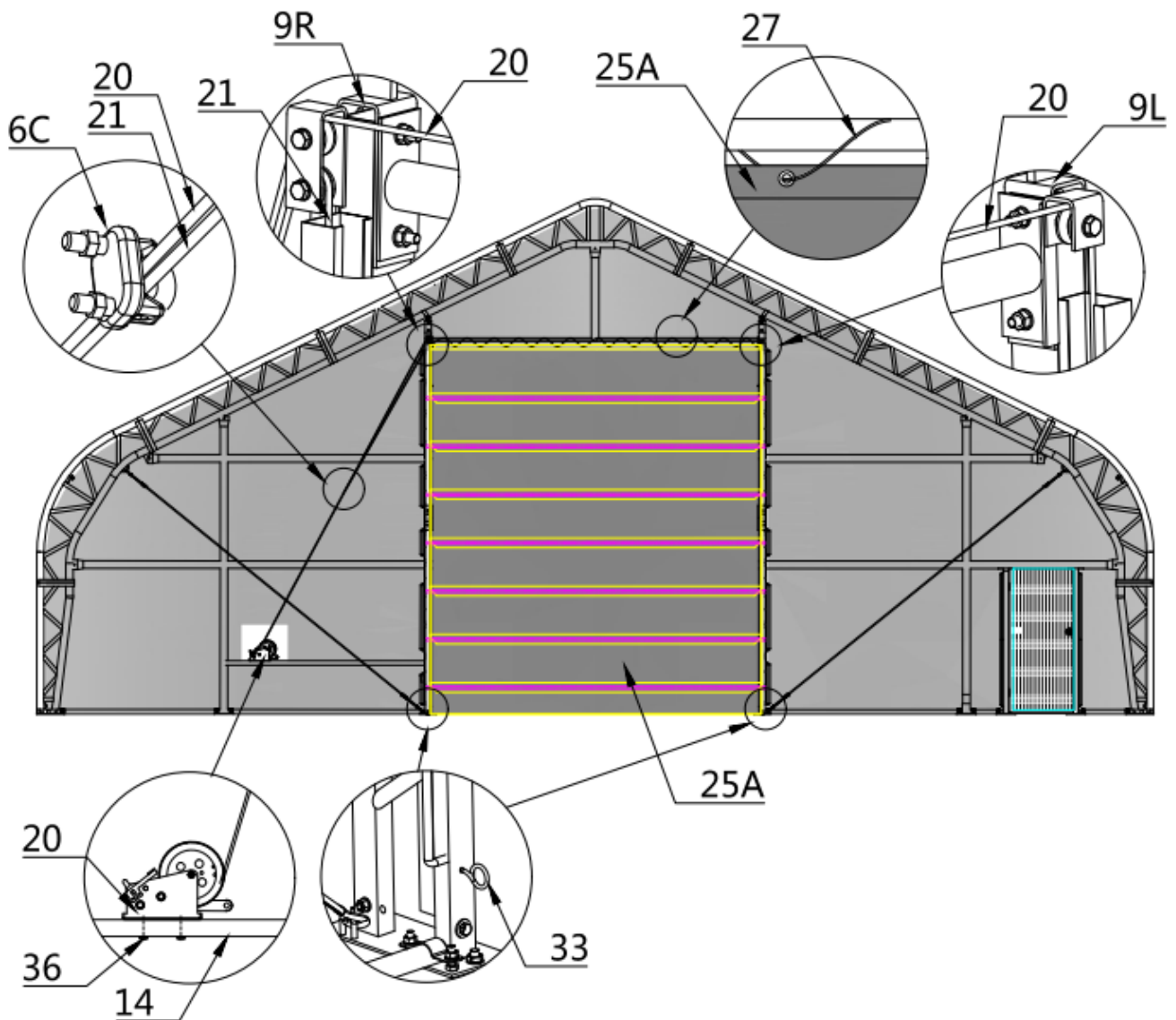

PARTS CODE	PART	QTY
6C		2
20		1
21		1
25A		1

STEP 19 :

3. DOOR CURTAIN INSTALLATION (THE FRONT AND REAR MOUNTING METHODS ARE THE SAME).

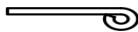

PARTS CODE	PART	QTY
6C		1
27		1
33		1
36		2

**STEP 20 :**

**1. INSTALL THE TOP CLOTH (#24A).**

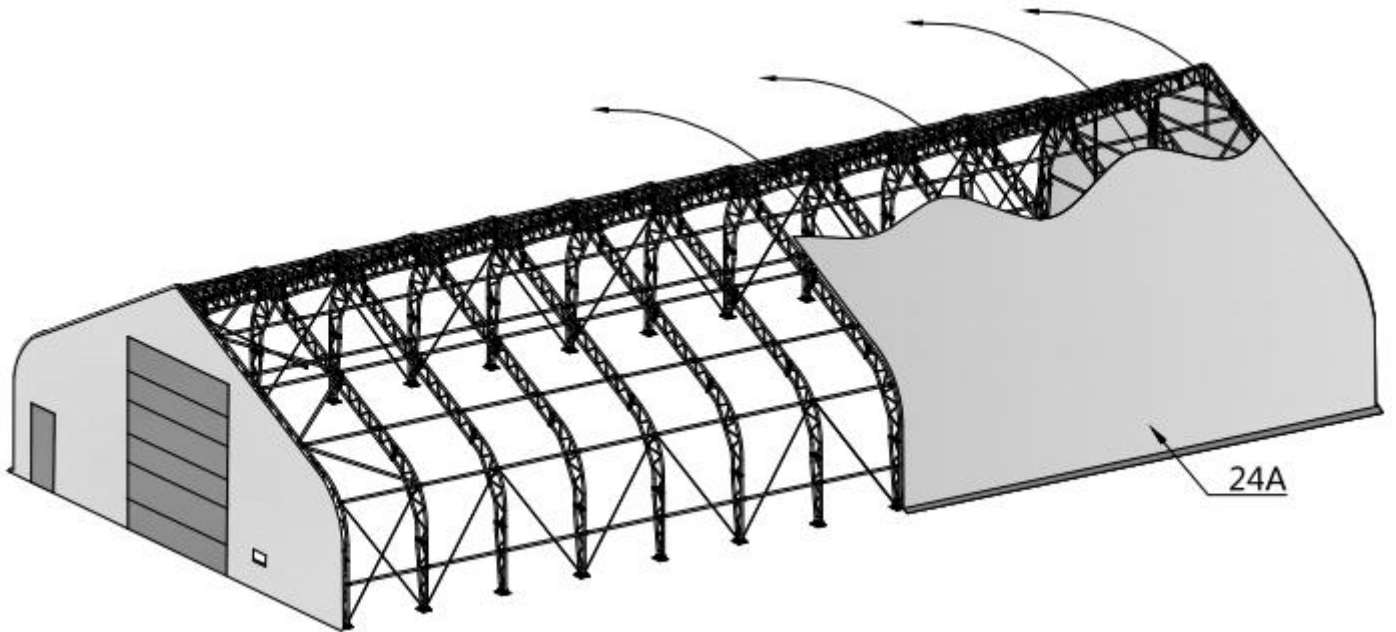

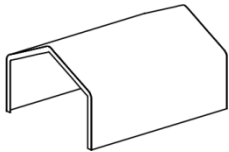

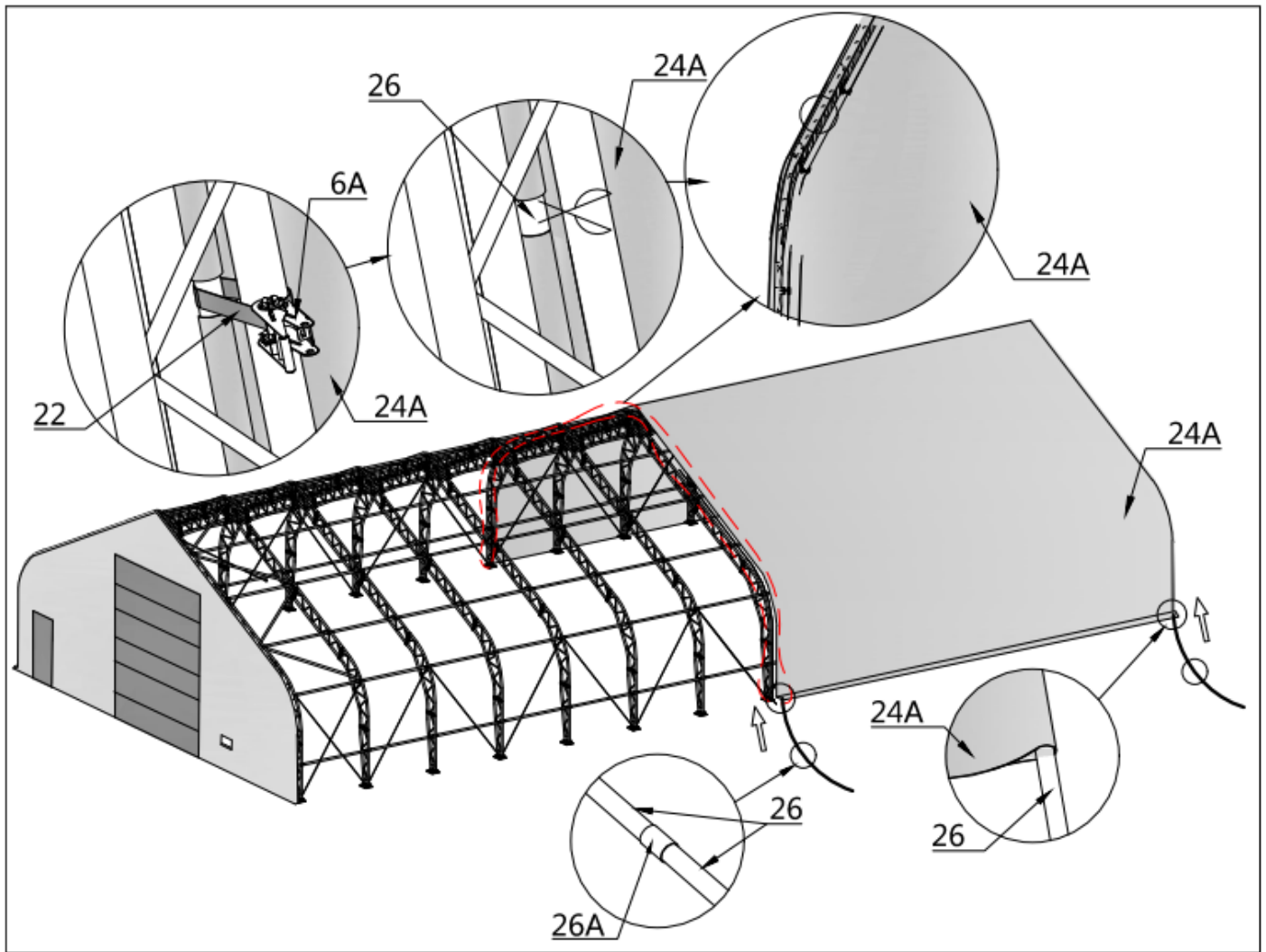

PARTS CODE	PART	QTY
24A		1

**STEP 20 :**

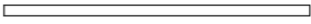
**2. INSTALL THE TOP CLOTH (#24A).**







PARTS CODE	PART	QTY
6A		18
26		6
26A		5
27		1
22		18

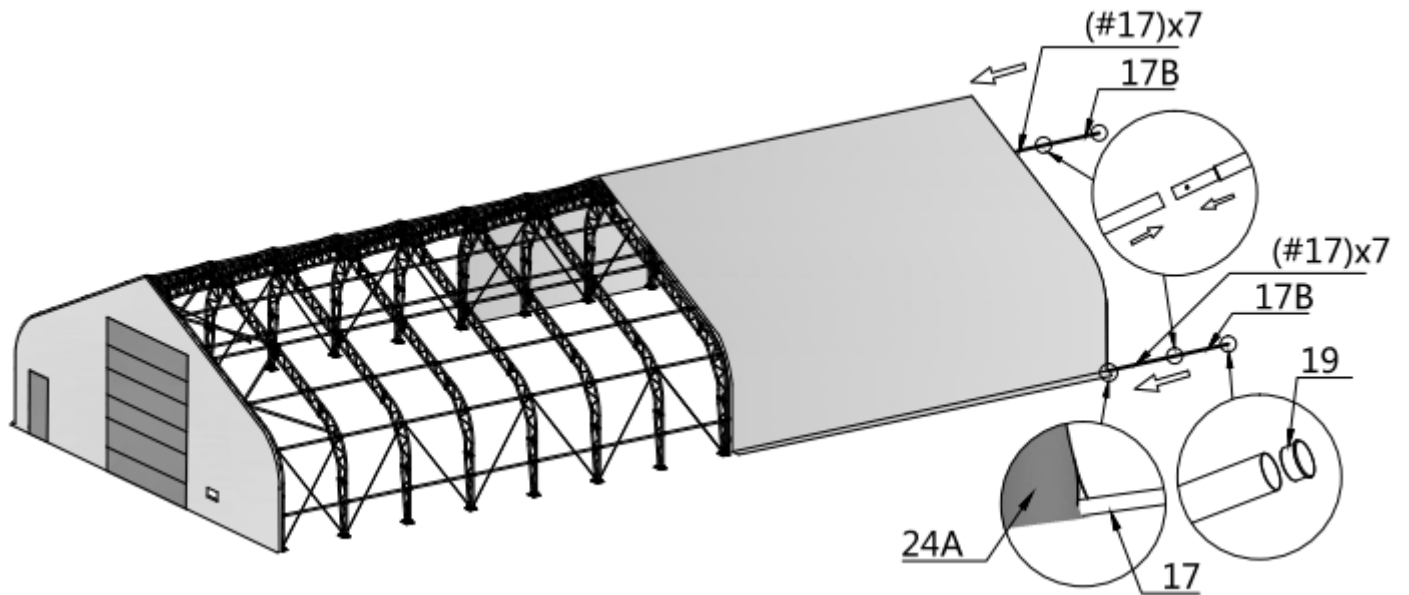

**STEP 20 :**

**3. INSTALL THE TOP CLOTH (#24A).**





PARTS CODE	PART	QTY
17		14
17B		2
19		4

**STEP 20 :**

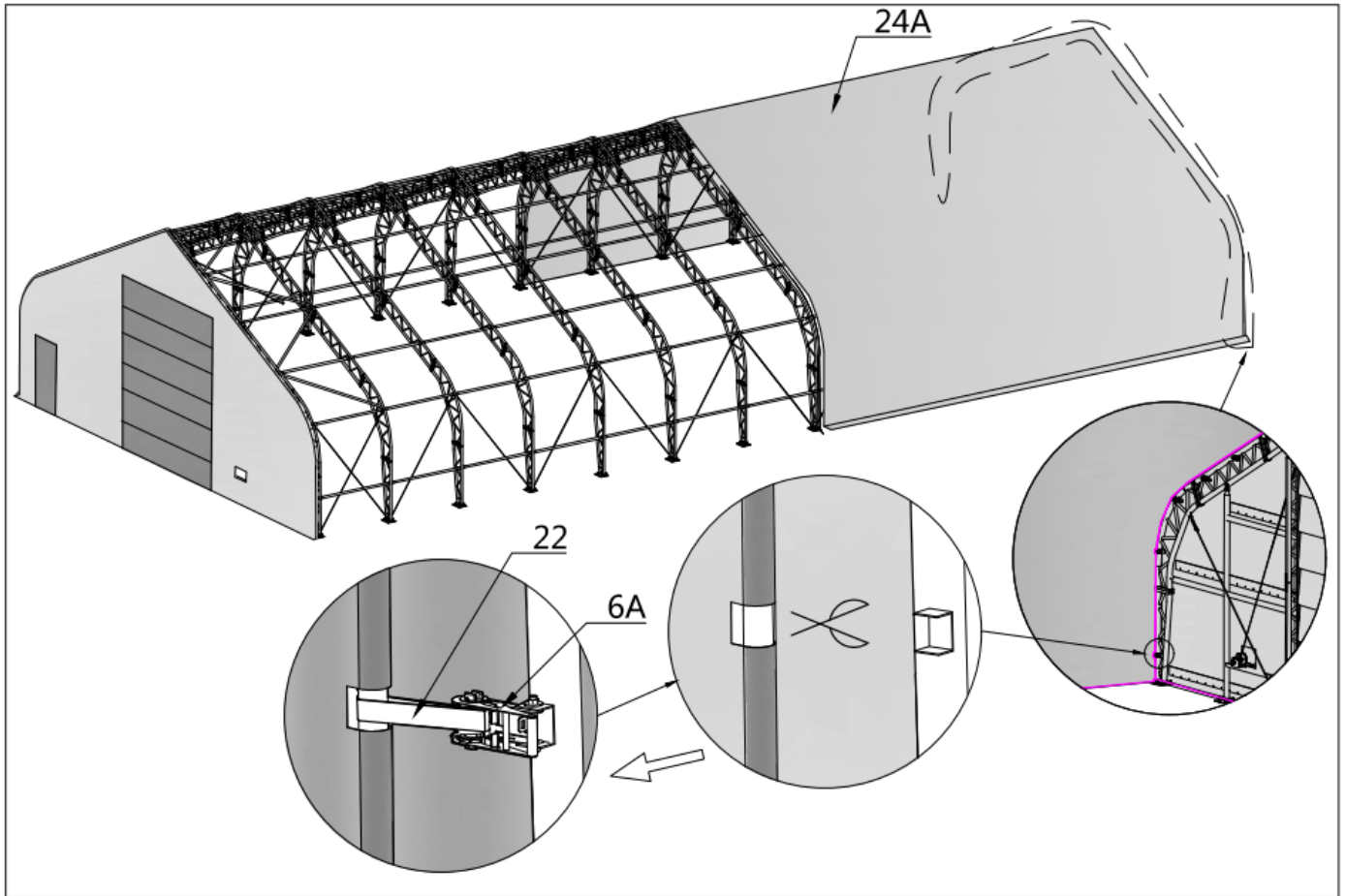
**4. INSTALL THE TOP CLOTH (#24A).**



PARTS CODE	PART	QTY
6A		18
22		18

**STEP 21 :**

**1. INSTALL THE TOP CLOTH (#24).**

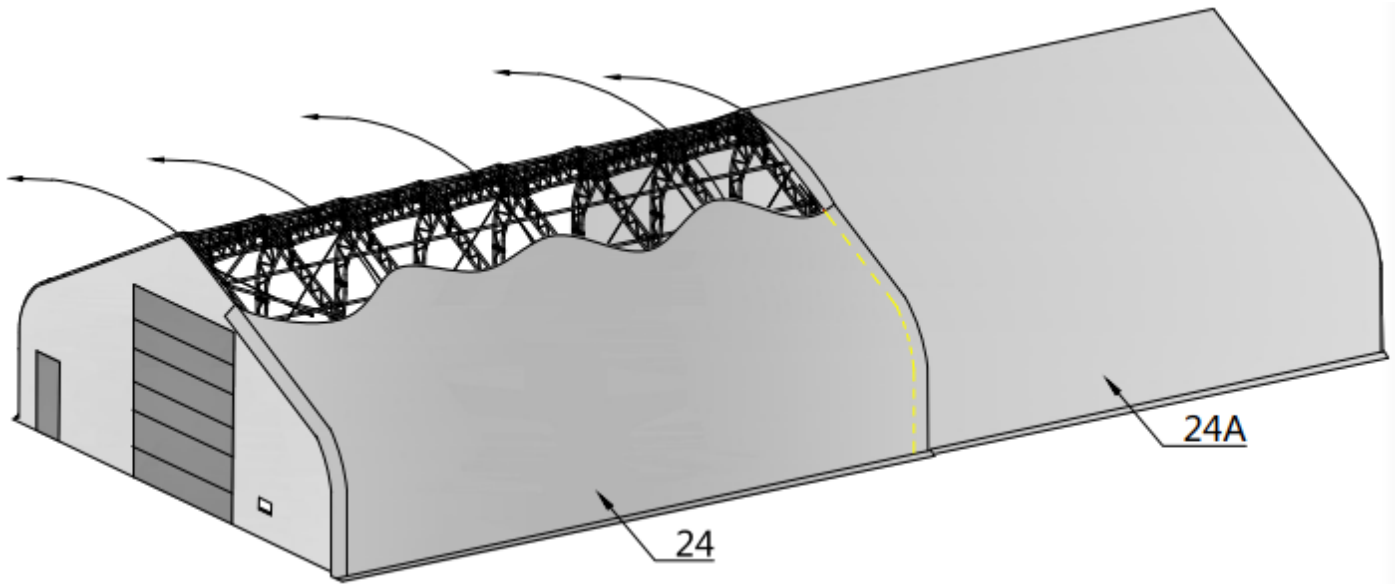

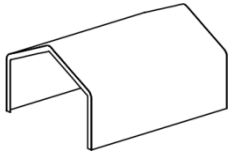

PARTS CODE	PART	QTY
24		1

**STEP 21 :**

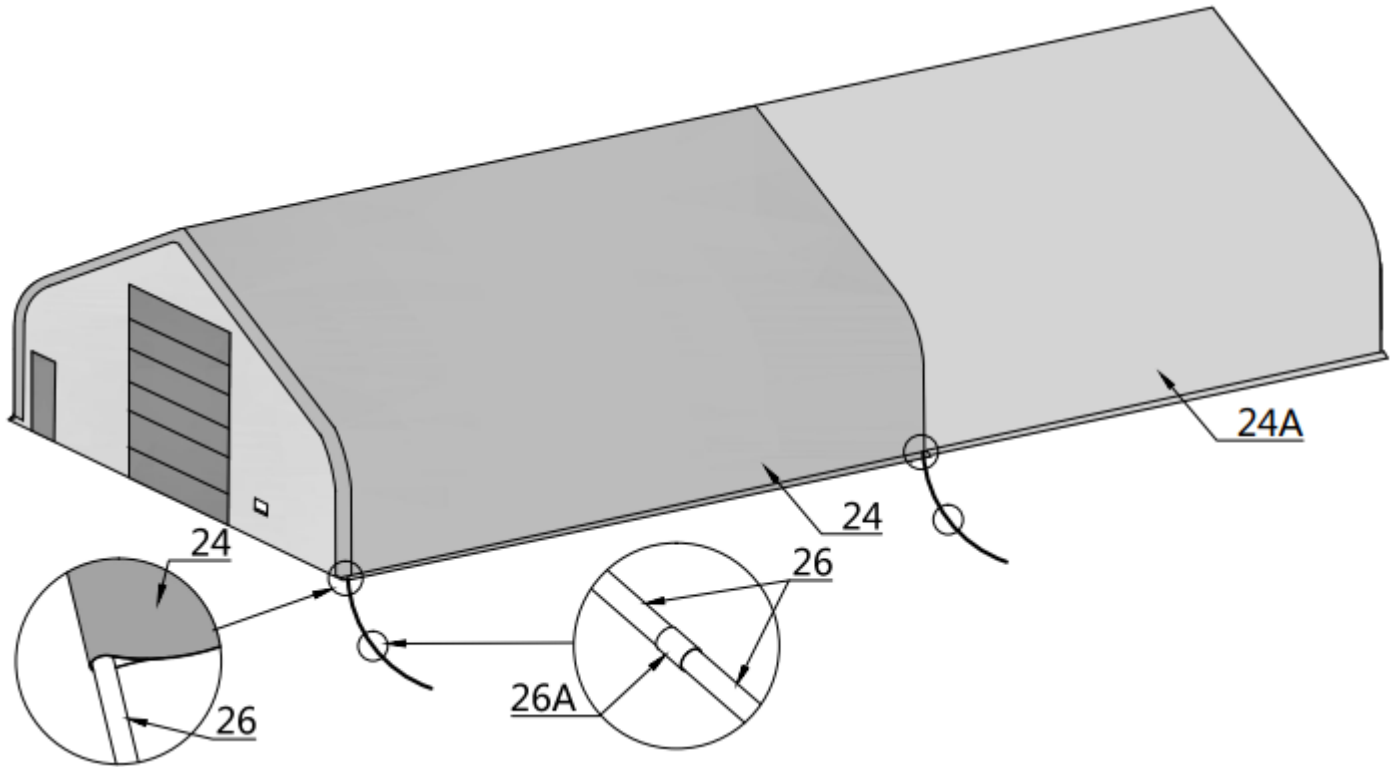
**2. INSTALL THE TOP CLOTH (#24).**



PARTS CODE	PART	QTY
26		12
26A		10

STEP 21 :

3. INSTALL THE TOP CLOTH (#24).

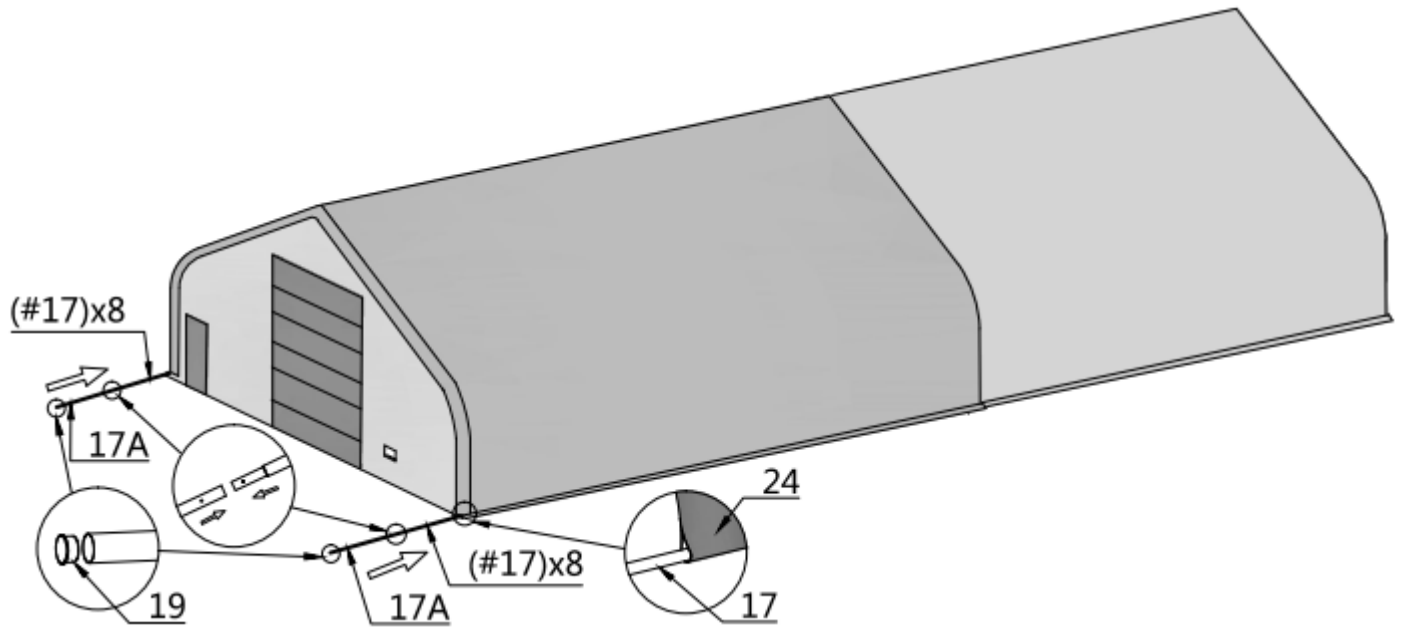



PARTS CODE	PART	QTY
17		16
17A		2
19		4

**STEP 21 :**

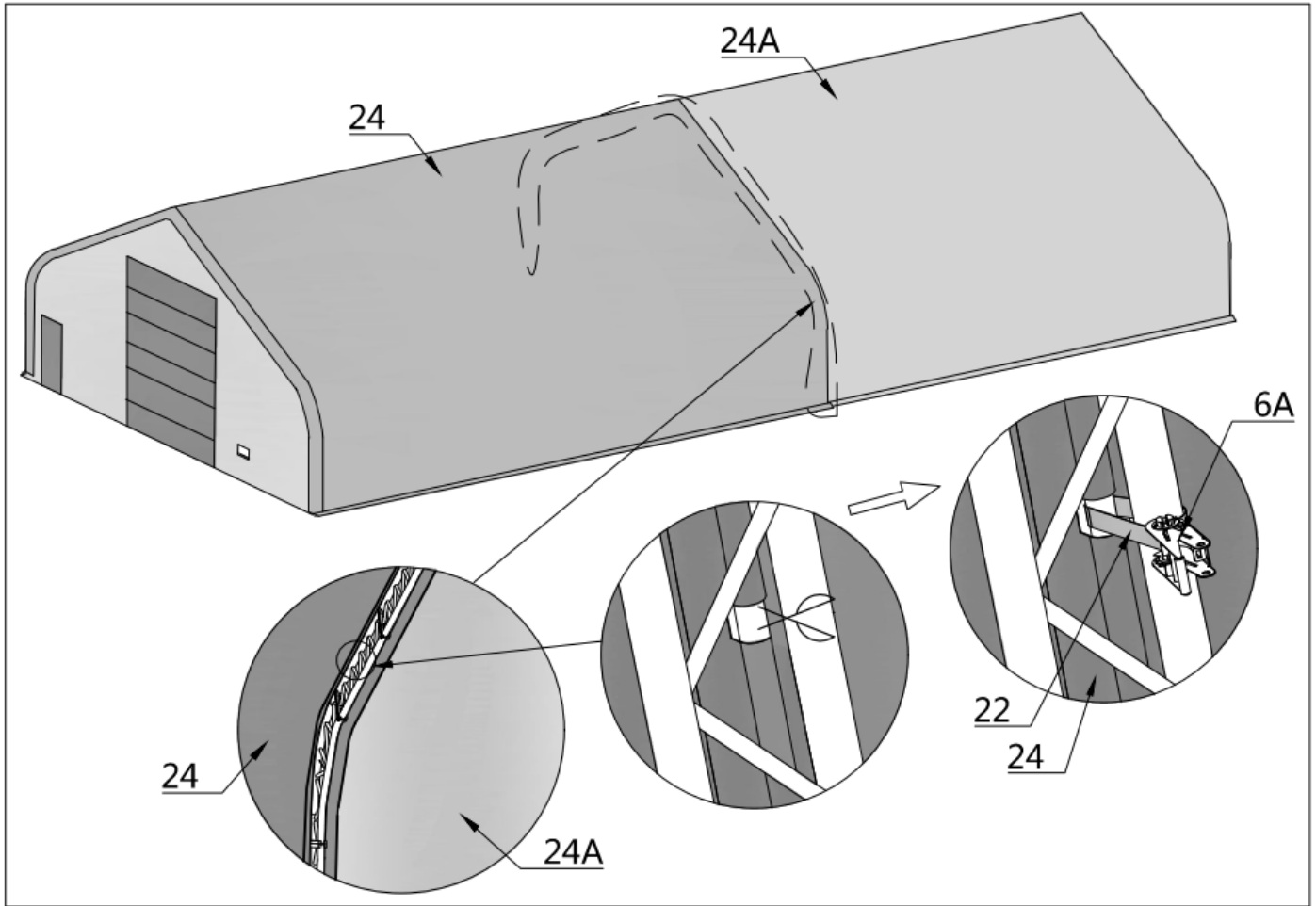
**4. INSTALL THE TOP CLOTH (#24).**





PARTS CODE	PART	QTY
6A		18
22		18

Step 21 :

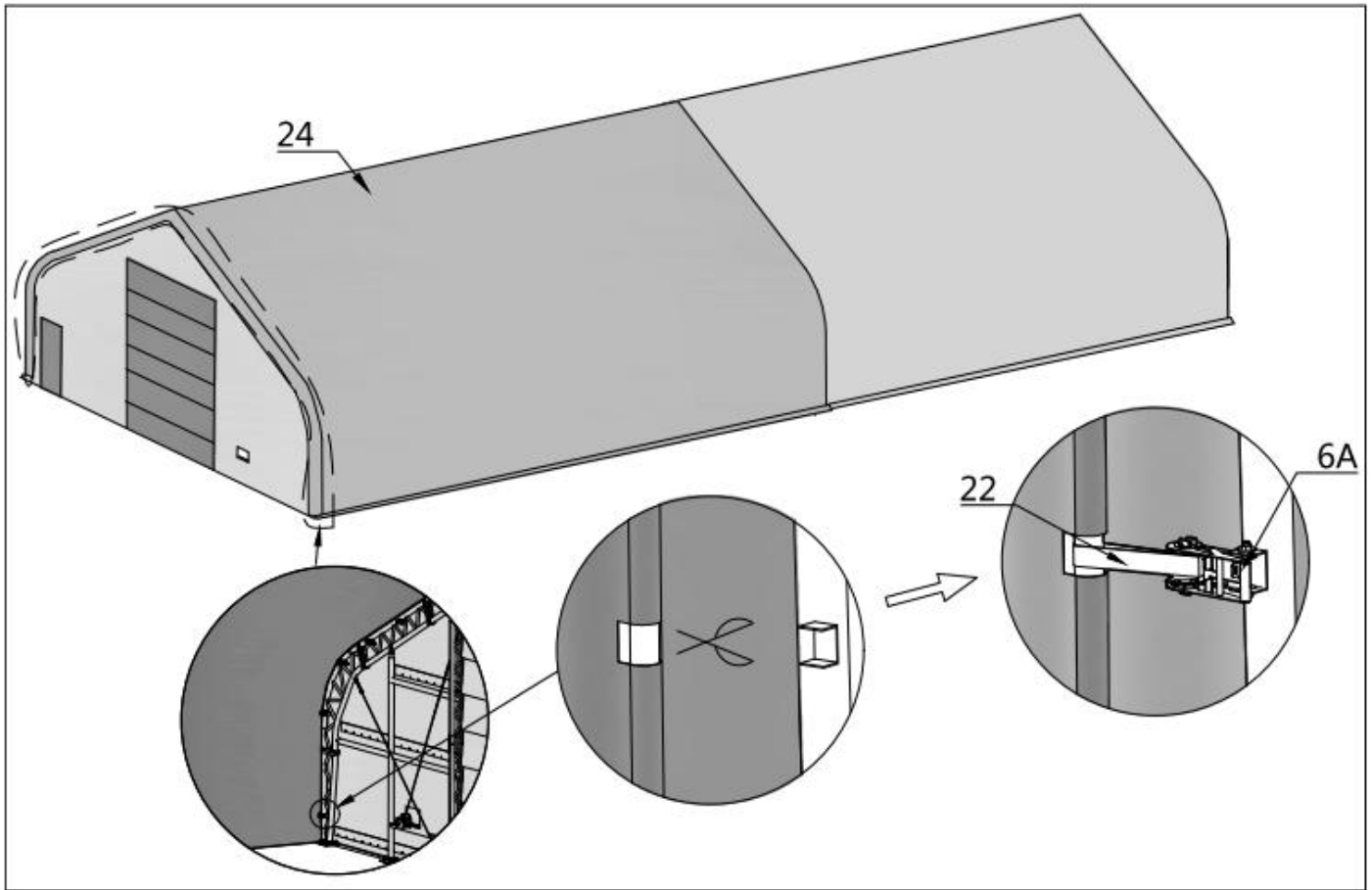

5. Install the top cloth (#24).

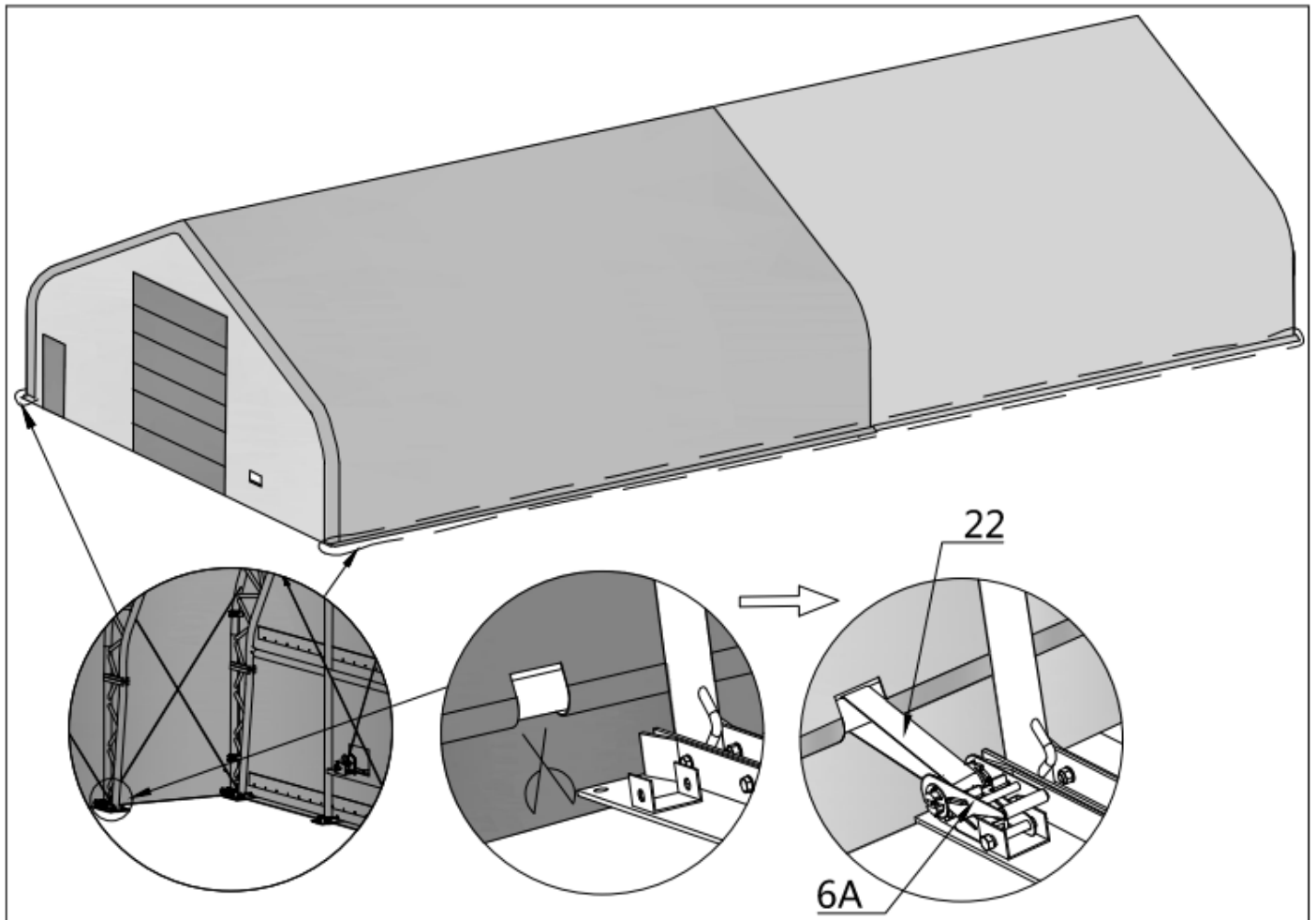

PARTS CODE	PART	QTY
6A		18
22		18

**Step 22 : Tension both sides of the top cloth with the tension device.**



PARTS CODE	PART	QTY
6A		32
22		32



**STEP 23 : TIE THE ROPE.**

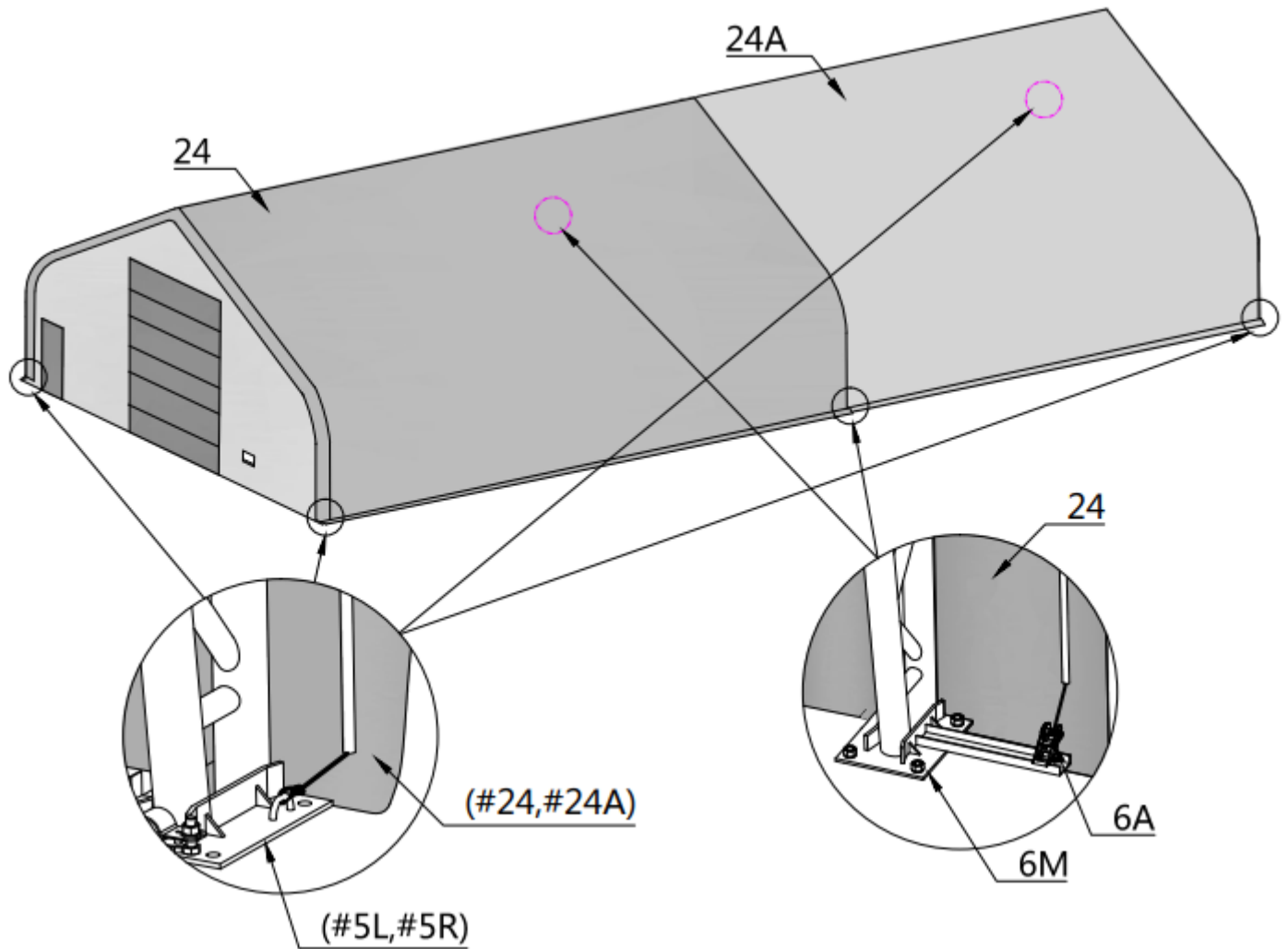

PARTS CODE	PART	QTY
6A		2

## **AFTER THE INSTALLATION**

Walk around and inspect the building periodically to make sure all components are still firmly secured and the whole building is well supported. Check all bolts and nuts as well as all connection points to make sure they are all in good position. Check the base plates, adjust the ropes and tie downs if required and clean the cover regularly.

Snow accumulating on the fabric cover must be removed as soon as possible. If snow becomes solid ice on the cover, it will increase the weight on the roof and collapses the building or reduce the life span eventually. Keep the building on a dry ground most of the time. Do not keep the fabric dirt skirt under water all the time, otherwise the fabric will deteriorate.

We strongly recommend you remove any snow from the roof immediately. Do not leave any snow load on the roof overnight. Keep 3 feet of clearance on all sides at all times. Do not allow snow to accumulate and pile up on the sides of the building. Otherwise the push from the sides toward inside will make the building collapsed at some point.