

TMG-DT40FW8 WITH MECHANICAL ROOL UP DOOR AND STEEL MANDOOR

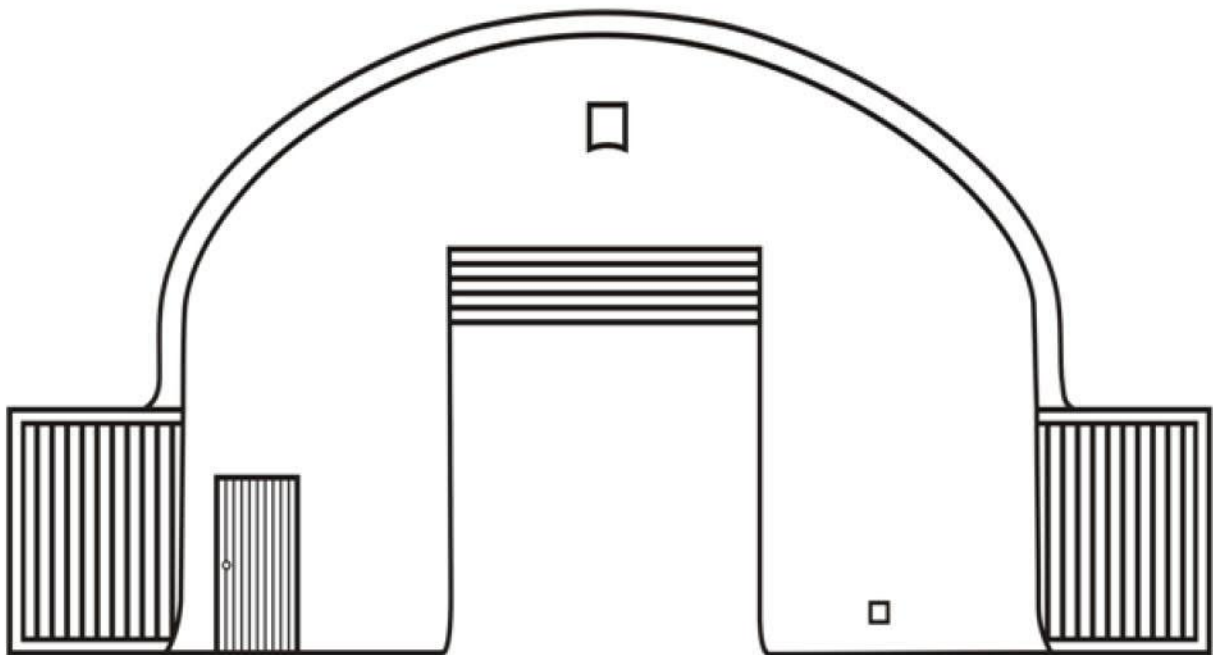

⚠ WARNING



- Please read and understand the product manual completely before assembly
- Check against the parts list to make sure all parts are received
- Wear proper safety goggles or other protective gears while in assembly
- Do not return the product to dealer. They are not equipped to handle your requests.

Missing parts or have questions on assembly?

Please call: 1-877-761-2819 or email: cs@tmgindustrial.com

MAIN SPECIFICATIONS :

- Overall assembled size : W12 x H7.1 (m) / W39.37x H23.29 (ft)
- Width : 12m / 39.37ft
- Height : 7.1 m / 23.29ft
- Front door:4.6x4.2(m)/15.09x13.78(ft)

PRIOR TO ASSEMBLY

Please read the instructions carefully before installation. It is very important to follow your local safety regulations and industry standards during installation. Regulations may include but are not limited to :











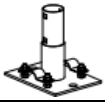
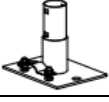

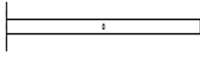
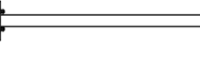
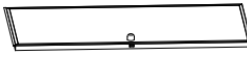
- Safety helmets, protective eyewear, and clothing
- Safety harnesses for all elevated workers
- Proper ladder, cage, and safety operation













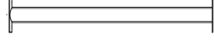

Check all components and parts before installation. All parts are marked with a part number, please refer to the parts list to make sure you have all parts.







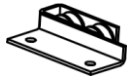
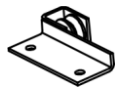



Choose a day with low or no wind to install, assembly is hard in heavy wind. Do not make any alterations to the structure. Do not hang any weights on the frame during installation, including parts. We are not responsible for any damages or injuries caused by inappropriate installation, unauthorized modifications or extreme weather.

This building is not intended for human occupancy.

It is recommended to tape or add foam/rubber on the frame where joints connect and where it touches the cover. This will help extend the life span of the cover.

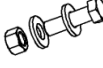
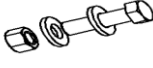
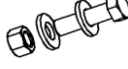
TMG-DT40FW8 PART LIST				
PARTS CODE	PICTURE	DESCRIPTION	LENGTH	QTY
7A		Baseplate	W150xL200mm	1
7B		Baseplate	W150xL200mm	3
7D		Baseplate of front door frame	W150xL200mm	2
9		Side vertical tube	L2620mm	1
9A		Side door left tube	L2027mm	1
9B		Side door right tube	L2027mm	1
9C		Side door	W925xL2005mm	1
9D		Side vertical tube	L2620mm	1
10A		Lower vertical tube	L2640mm	1
10B		Lower vertical tube	L2640mm	1
10L		Front vertical door rail (left side lower part)	L2625mm	1
10R		Front vertical door rail (right side lower part)	L2625mm	1
11L		Front vertical door rail (left side upper part)	L2065mm	1
11R		Front vertical door rail (right side upper part)	L2065mm	1
11A		Middle vertical tube	L2014mm	2
12		Upper vertical tube	L1616mm	2

13		Upper vertical tube	L2146mm	1
14A		Bottom tension bar	L1590mm	3
14B		Front door hand winch crossing tube	L1635mm	1
15A		Transverse tube	L1781mm	2
15B		Side door upper tube	L1642mm	1
16A		Middle transverse tube	L1635mm	2
17		Upper transverse tube	L2500mm	1
18		Upper transverse tube	L2920mm	2
18A		Front roll up door dropping tubes (to connect #18B)	L2356mm	7
18B		Front roll up door dropping tubes (to connect #18A)	L2359mm	7
19		Upper transverse tube	L2666mm	1
20		Support tube	L2985mm	3
21		Expansion bolts	φ 16x150mm	16
23A		Wire rope for front door hand winch	15m	1
23B		Right pulley system for front door	L150mm	1
23C		Left pulley system for front door	L150mm	1
23D		Roll up door hand winch	(1200 lb)	1

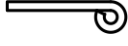
24C		Front vertical door rail connection plate	L240mm	2
24D		Front vertical door rail end plate (floatable to keep door rail straight)	L220mm	2
25		Tube clamps	φ58	19
25A		Tapping screw	#12x25mm	68
25B		Pressing plate	L2000mm	6
25C		Pressing plate	L1000mm	1
27		Hex bolt and nuts	M10x50mm	19
29		Hex bolt and nuts	M8x90mm	29
29A		Hex bolt and nuts	M10x70mm	26
30		Tube end water plug	φ32	6
33		Braided rope	100m	1
34		Front truss fabric cover panel	W12.1xL7.3m	1
34A		Front roll up door cover panel	W4560xL4870mm	1
38		Front fabric tarp secure pin	L200m	1

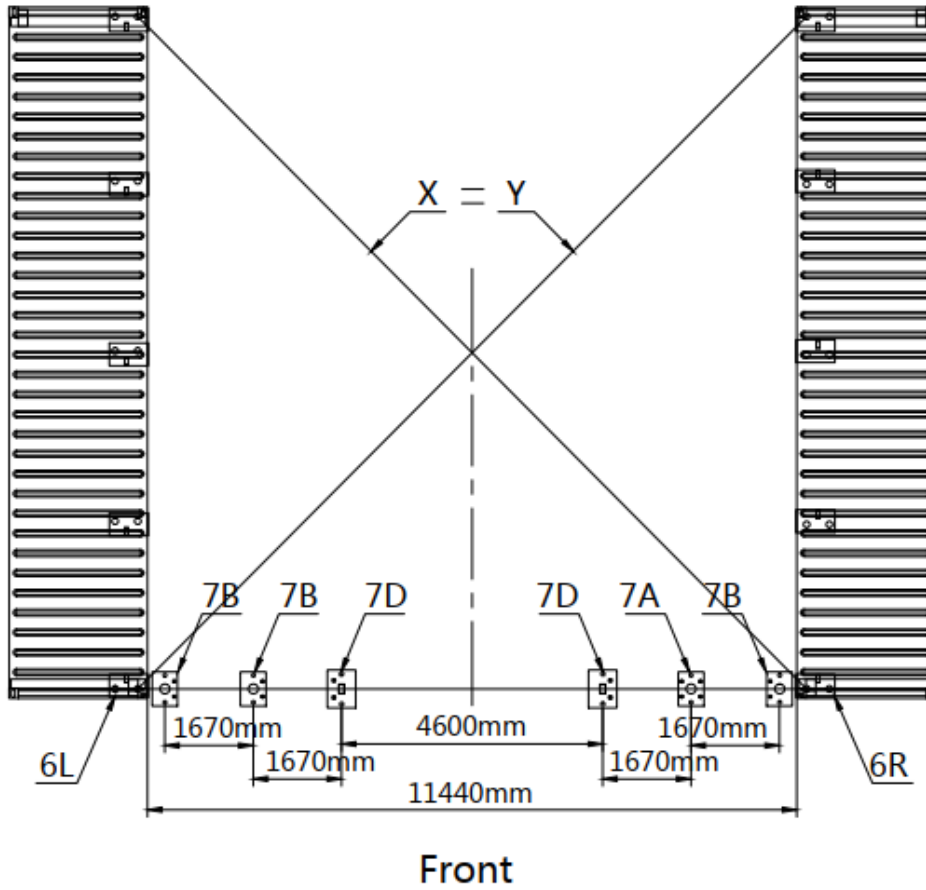

STEP 1 : REVIEW THE WHOLE STRUCTURE AND CHOOSE THE PROPER INSTALLATION SITE.

- Place the containers making sure they are parallel and the correct width apart the diagonal X and Y must be equal. Baseplates must be bolted firmly with expansion bolts, It is concrete expansion bolt.

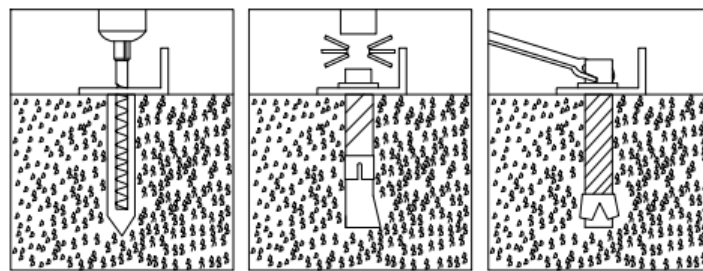

- Installation diagram of expansion bolt.

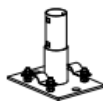



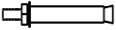



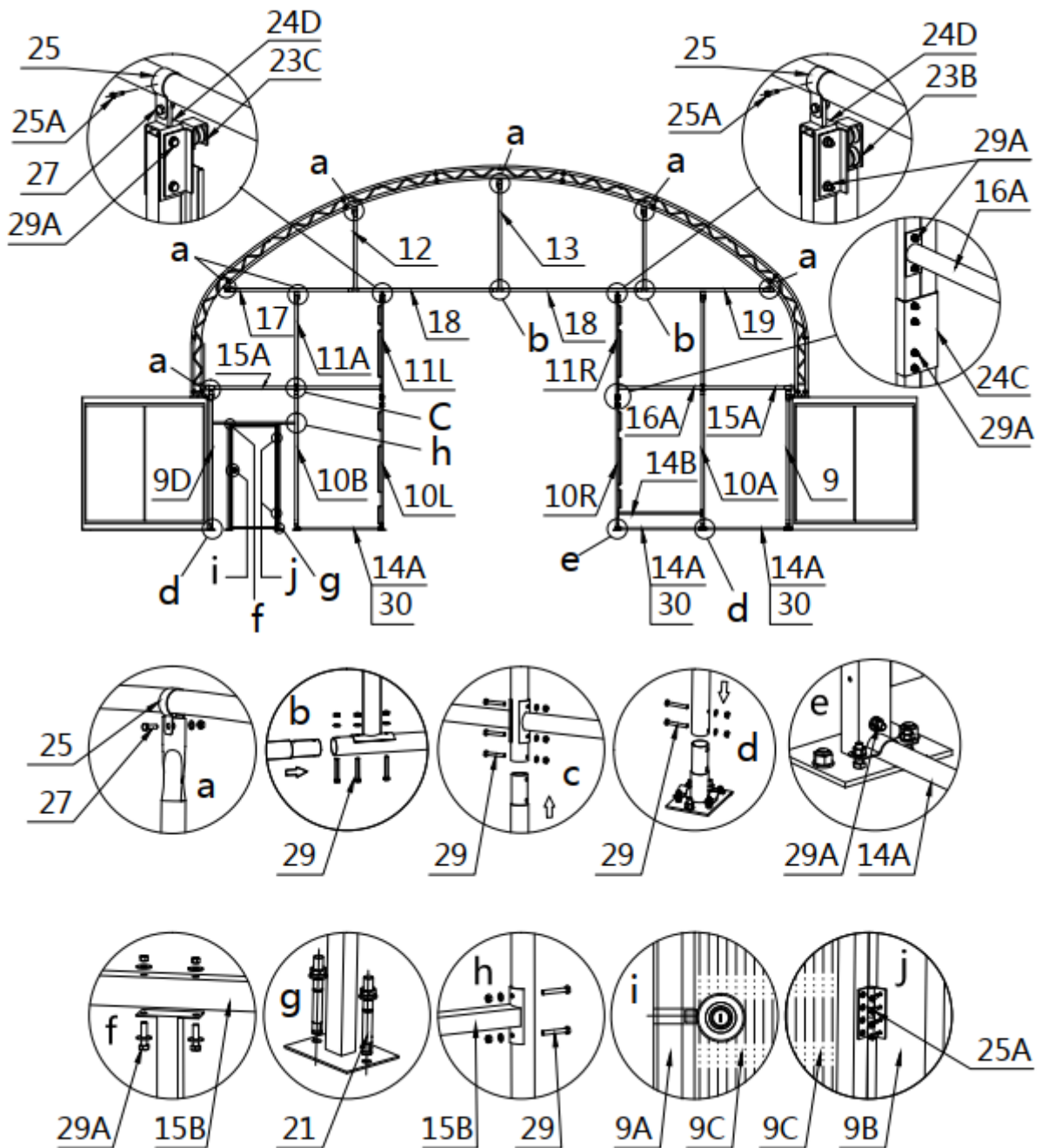

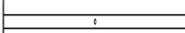
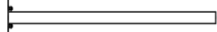



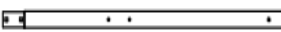



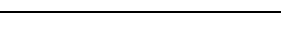
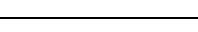
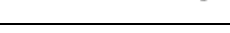





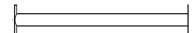



PARTS CODE	PART	QTY
7A		1
7B		3

PARTS CODE	PART	QTY
7D		2
21		12

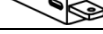
STEP 2 : FRONT TRUSS TO COMPLETE.





PARTS CODE	PART	QTY
9		1
9A		1
9B		1
9C		1
9D		1
10A		1
10B		1
10L		1
10R		1
11L		1
11R		1
11A		2
12		2
13		1
14A		3
14B		1
15A		2

PARTS CODE	PART	QTY
15B		1
16A		2
17		1
18		2
19		1
21		4
23B		1
23C		1
24C		2
24D		2
25		13
25A		10
27		13
29		29
29A		24
30		6

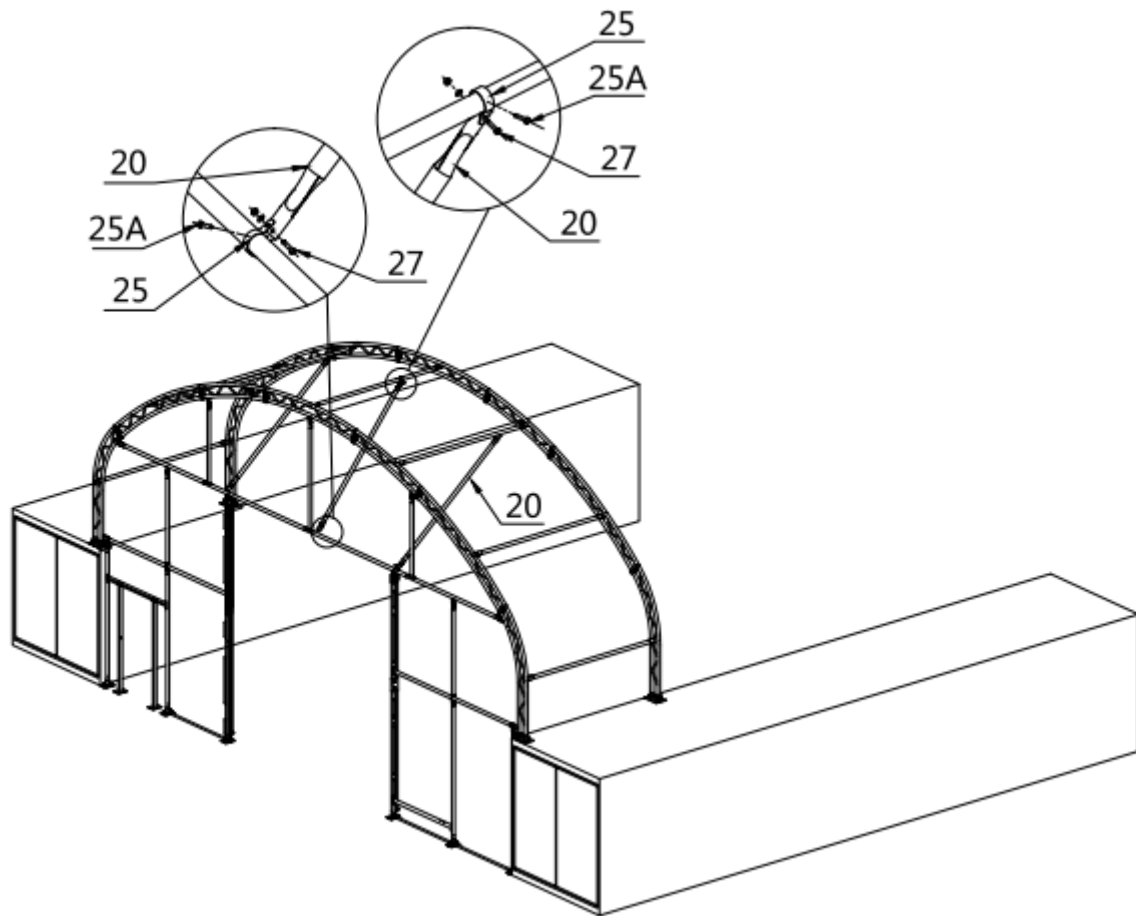
STEP 3 : INSTALL THE TOP SUPPORT TUBE.



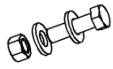

PARTS CODE	PART	QTY
20		3
25		6

PARTS CODE	PART	QTY
25A		6
27		6

STEP 4 : INSTALL FRONT COVER PANEL.

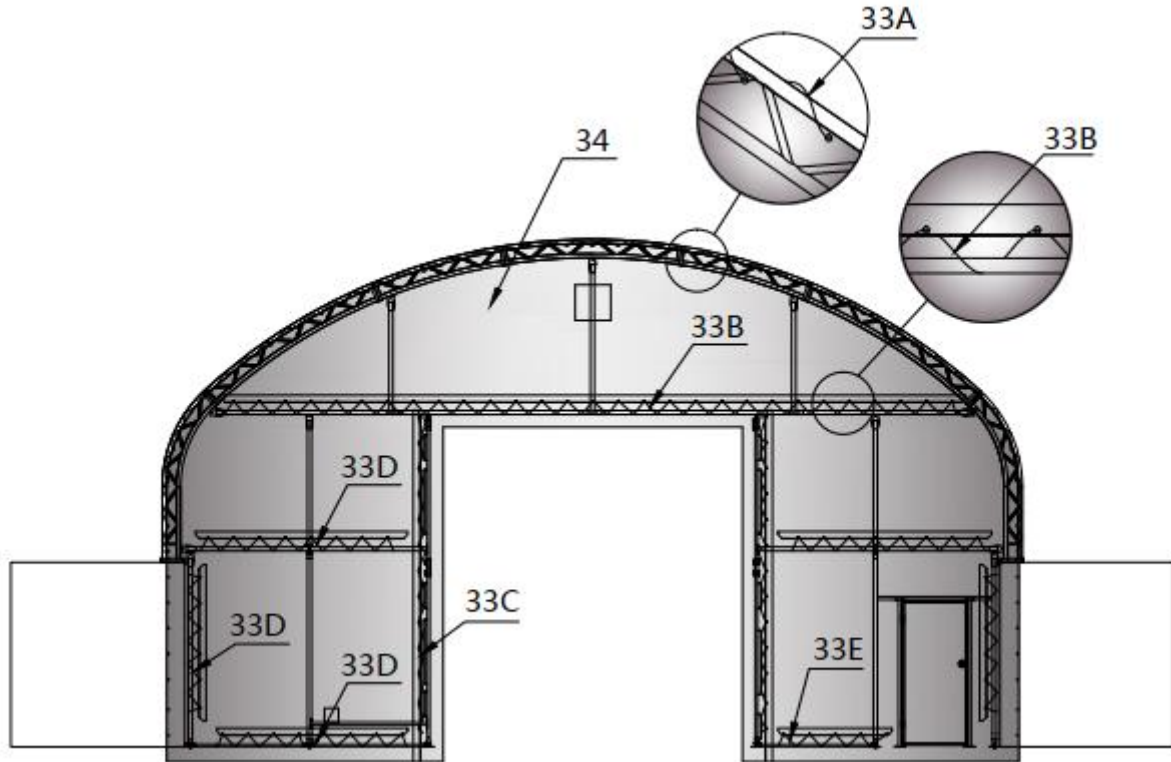
- Lift up (#34) cover panel, starting from the center point of the frame (highest ridge point) use ropes (#33) through the grommets to tie the panel to the truss firmly. All grommets need to be tied to the frame as shown.





PARTS CODE	PART	QTY
34		1

ROPE SHEAR SIZE		
33		Qty
A	13m	2
B	16m	1
C	8m	2
D	4m	5
E	3m	1

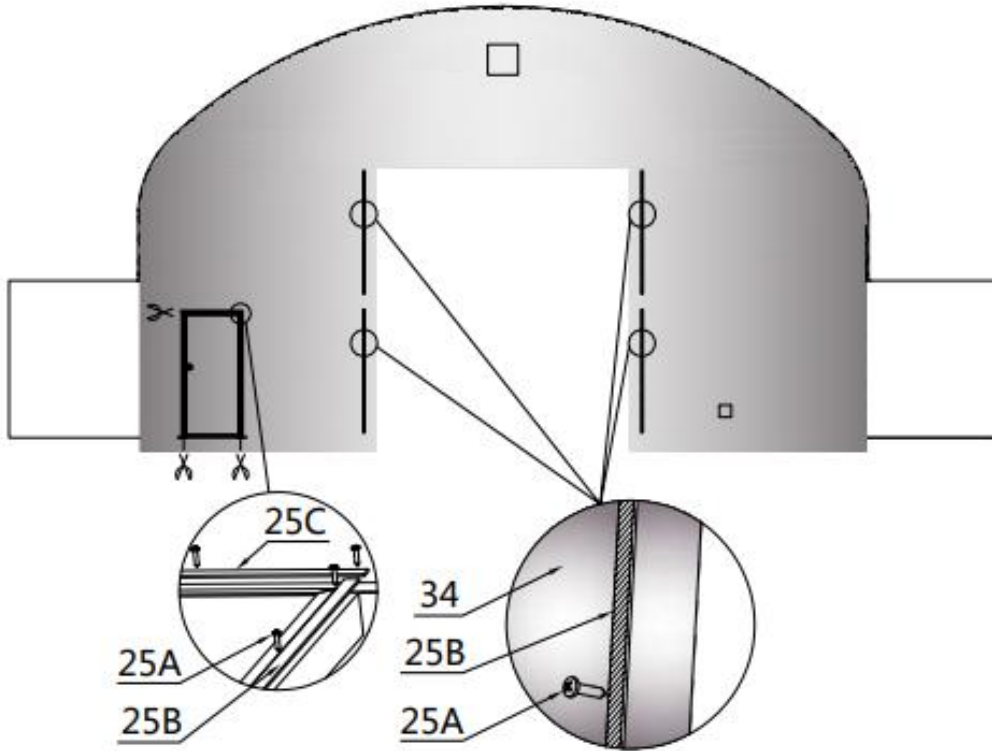
- Install the front door metal strip.





PARTS CODE	PART	QTY
25A		52
25B		6

PARTS CODE	PART	QTY
25C		1

STEP 5 : INSTALL MECHANICAL ROLL UP DOORS.

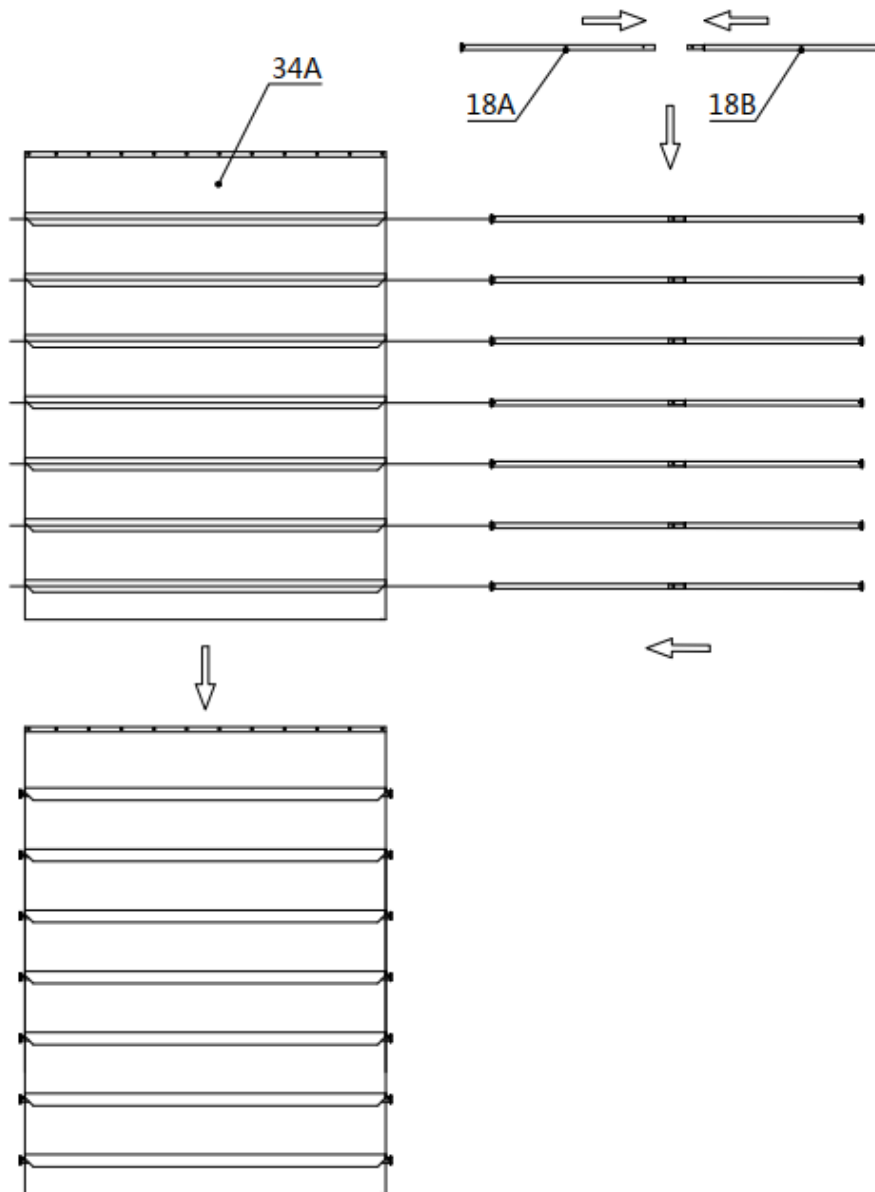
- Door curtain installation.





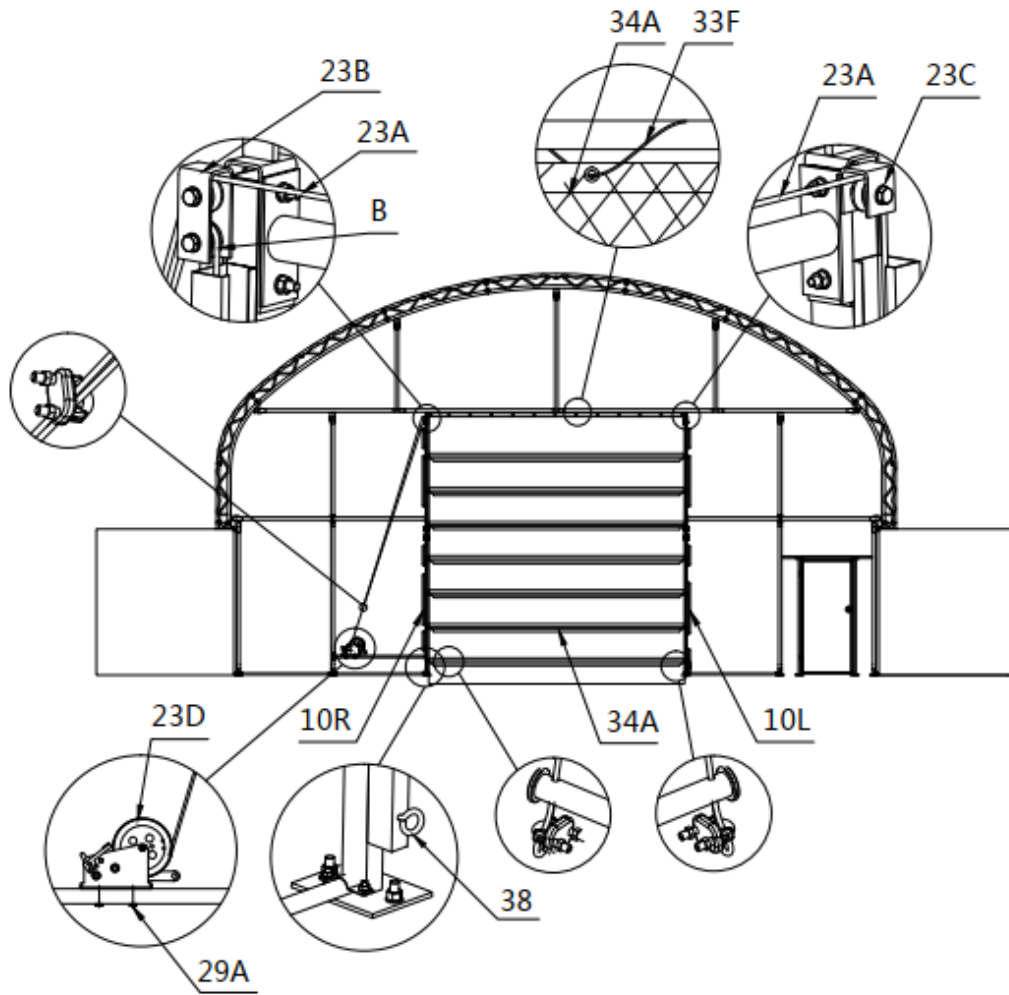

PARTS CODE	PART	QTY
18A		7
18B		7

PARTS CODE	PART	QTY
34A		1

- Front door installation, please look at the door from inside.
- The hand winch (#23D) comes with a shorter cable, we call it cable (#B).

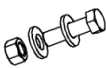
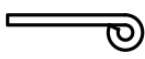

PARTS CODE	PART	QTY
23A		1
23D		1
29A		2
38		1

ROPE SHEAR SIZE		
33		Qty
F	7m	1

AFTER THE INSTALLATION

Walk around and inspect the shelter periodically to make sure all components are still firmly secured and the whole shelter is well supported. Check all bolts and nuts as well as all connection points to make sure they are all in good position. Check the base plates, adjust the ropes and tie downs if required and clean the cover regularly.

Snow accumulating on the fabric cover must be removed as soon as possible. If snow becomes solid ice on the cover, it will increase the weight on the roof and may collapse the shelter or reduce the life span.

Keep the shelter on a dry ground most of the time. Do not keep the fabric dirt skirt under water all the time, otherwise the fabric will deteriorate.

We strongly recommend you remove any snow from the roof immediately. Do not leave any snow load on the roof overnight. Keep 3 feet of clearance on all sides at all times. Do not allow snow to accumulate and pile up on the sides of the building. Otherwise the pressure from the sides will push inwards and could lead to a collapse.

TMG-DT40BW8 BACK WALL ONLY

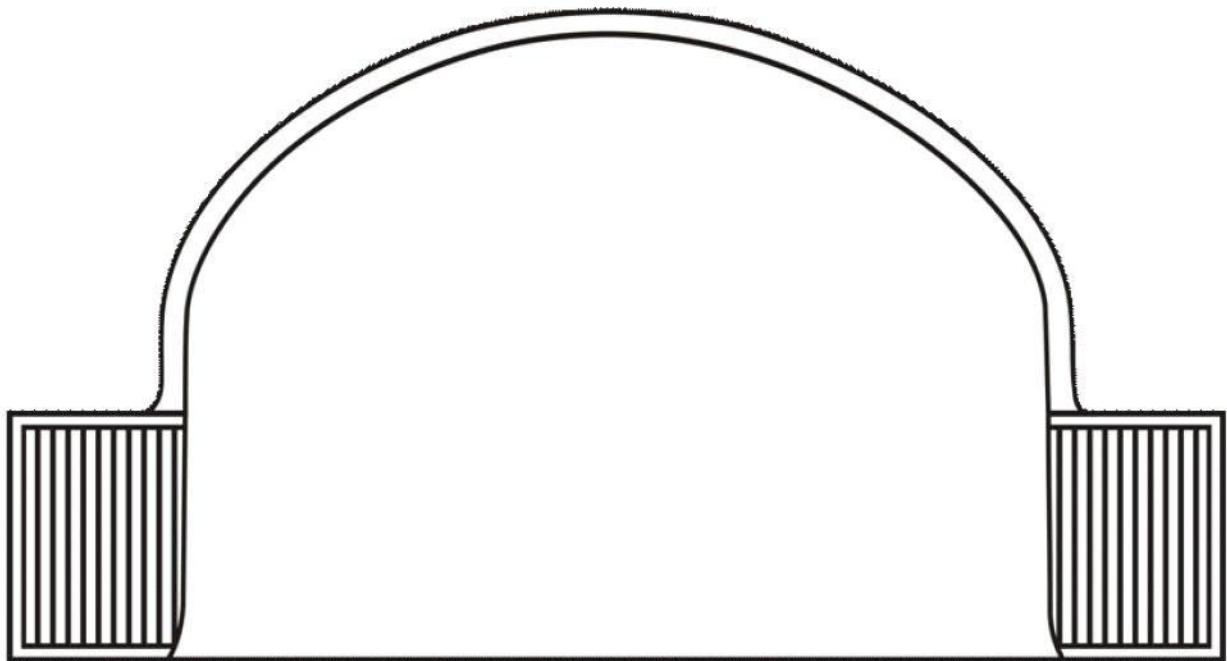

⚠ WARNING



- Please read and understand the product manual completely before assembly
- Check against the parts list to make sure all parts are received
- Wear proper safety goggles or other protective gears while in assembly
- Do not return the product to dealer. They are not equipped to handle your requests.

Missing parts or have questions on assembly?

Please call: 1-877-761-2819 or email: cs@tmgindustrial.com

MAIN SPECIFICATIONS :

- Overall assembled size : W12 x H7.1 (m) / W39.37x H23.29 (ft)
- Width : 12 m / 39.37ft
- Height : 7.1 m / 23.29ft

PRIOR TO ASSEMBLY

Please read the instructions carefully before installation. It is very important to follow your local safety regulations and industry standards during installation. Regulations may include but are not limited to:

- Safety helmets, protective eyewear, and clothing
- Safety harnesses for all elevated workers
- Proper ladder, cage, and safety operation











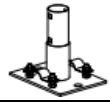
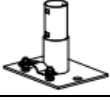



Check all components and parts before installation. All parts are marked with a part number, please refer to the parts list to make sure you have all parts.





Choose a day with low or no wind to install, assembly is hard in heavy wind. Do not make any alterations to the structure. Do not hang any weights on the frame during installation, including parts. We are not responsible for any damages or injuries caused by inappropriate installation, unauthorized modifications or extreme weather.

This building is not intended for human occupancy.

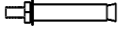
It is recommended to tape or add foam/rubber on the frame where joints connect and where it touches the cover. This will help extend the life span of the cover.

TMG-DT40BW8 PART LIST

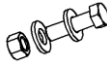
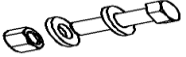
PARTS CODE	PICTURE	DESCRIPTION	LENGTH	QTY
7A		Baseplate	W150xL200mm	3
7B		Baseplate of front door frame	W150xL200mm	2
7C		Baseplate for bottom tension bar	W80xL200mm	4
9		Side vertical tube	L2620mm	2
10		Lower vertical tube	L2640mm	3
11		Middle vertical tube	L2034mm	3
12		Upper vertical tube	L1616mm	2
13		Upper vertical tube	L2146mm	1
14		Bottom tension bar	L2740mm	4
15		Transverse tube	L2929mm	2
16		Middle transverse tube	L2784mm	2
17		Upper transverse tube	L2500mm	1
18		Upper transverse tube	L2920mm	2
19		Upper transverse tube	L2666mm	1
20		Support tube	L2985mm	3
21		Expansion bolts	φ 16x150mm	18

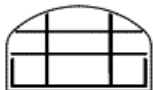
25		Tube clamps	φ58	15
25A		Tapping screw	#12x25mm	6
27		Hex bolt and nuts	M10x50mm	15
29		Hex bolt and nuts	M8x90mm	28
30		Tube end water plug	φ 32	8
33		Braided rope	100m	1
35		Rear truss fabric cover panel	W12.1xL7.3m	1

STEP 1 : REVIEW THE WHOLE STRUCTURE AND CHOOSE THE PROPER INSTALLATION SITE.

- Place the containers making sure they are parallel and the correct width apart the diagonal X and Y must be equal. Baseplates must be bolted firmly with expansion bolts, It is concrete expansion bolt.

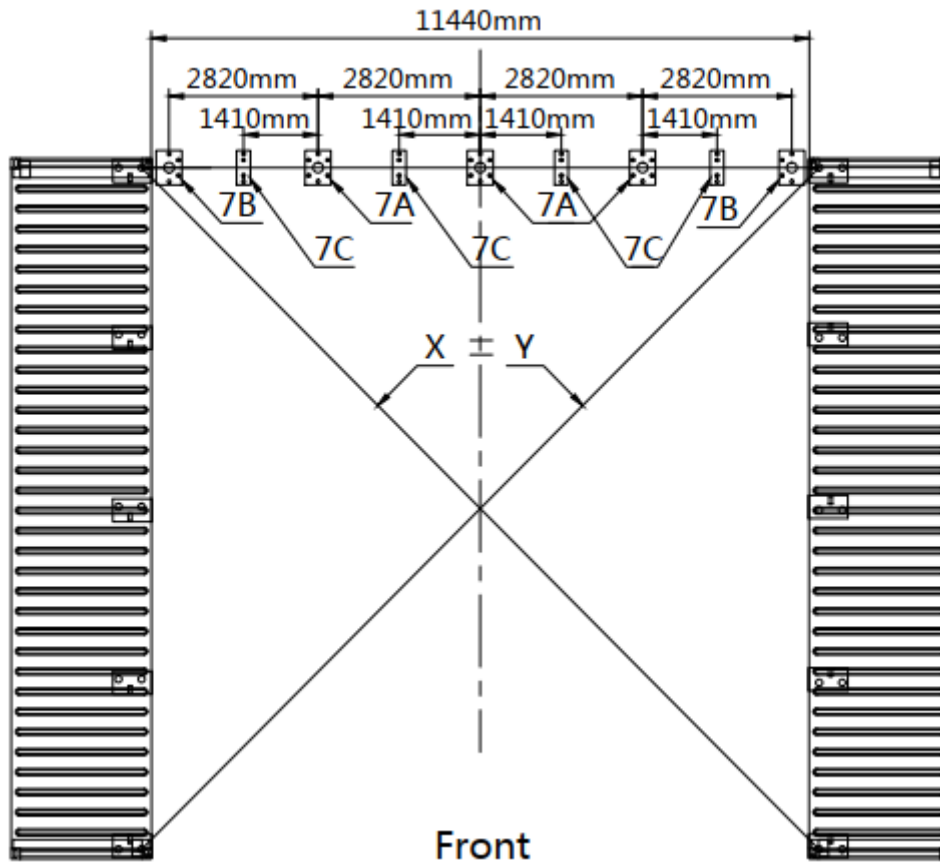

- Installation diagram of expansion bolt.

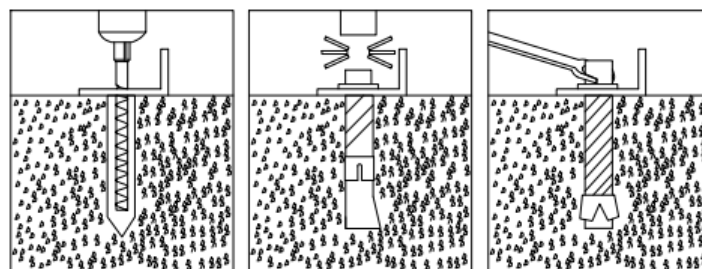

PARTS CODE	PART	QTY
7A		3
7B		2

PARTS CODE	PART	QTY
7C		4
21		18

STEP 2 : REAR TRUSS TO COMPLETE.

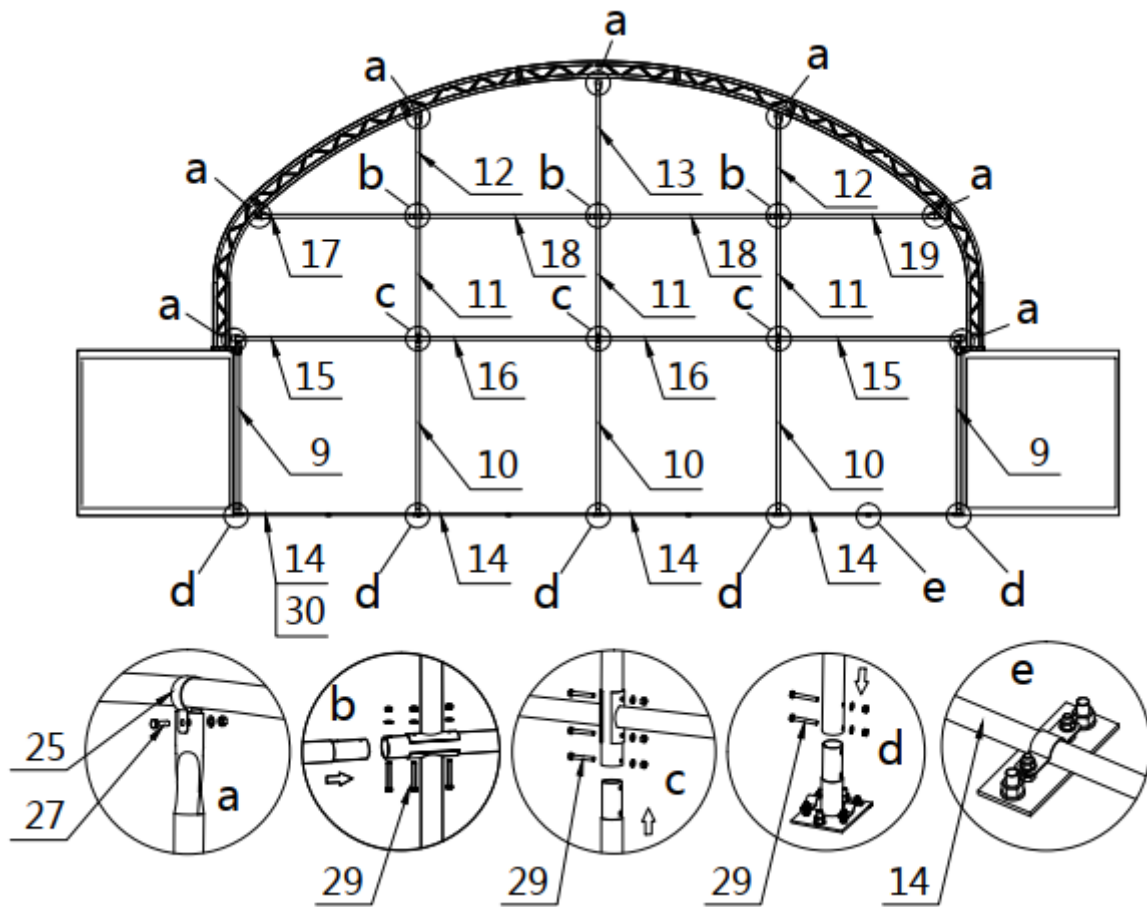



PARTS CODE	PART	QTY
9		2
10		3
11		3
12		2
13		1
14		4
15		2
16		2

PARTS CODE	PART	QTY
17		1
18		2
19		1
25		9
27		9
29		28
30		8

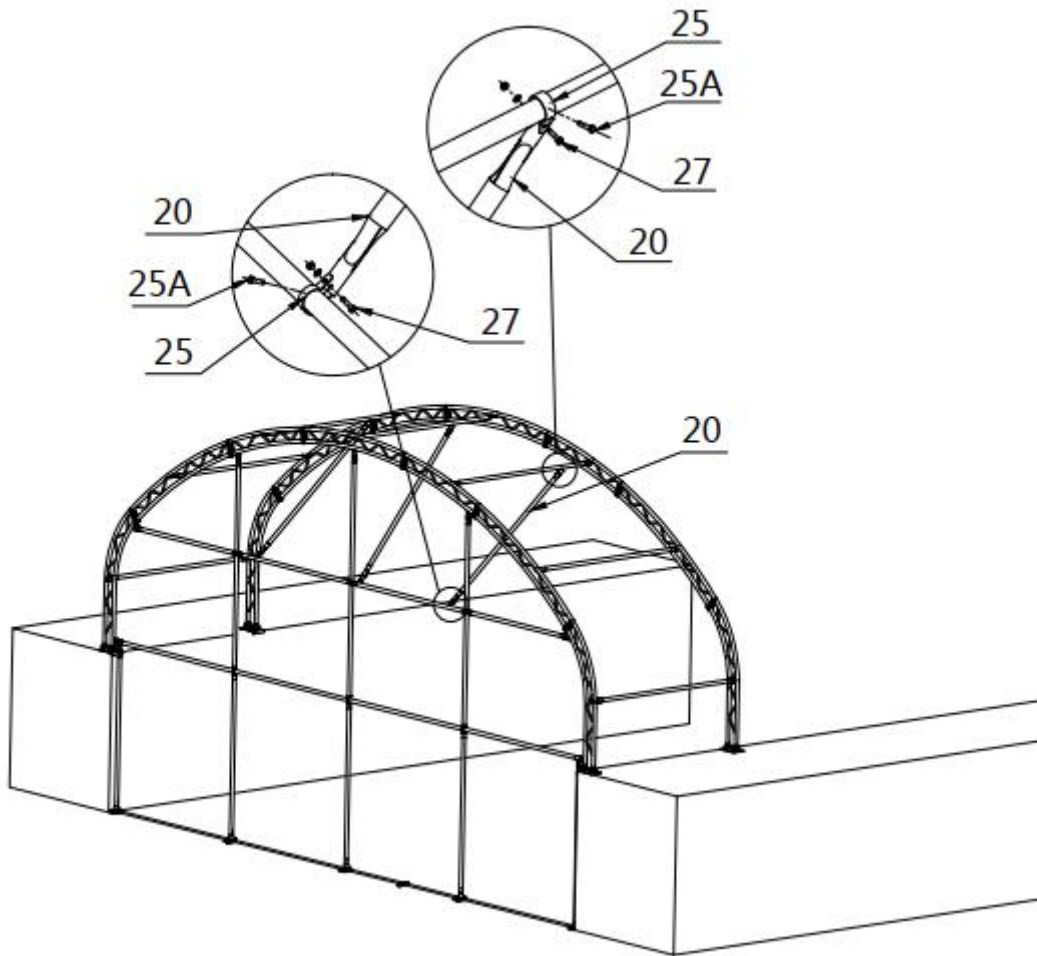
STEP 3 : INSTALL THE TOP SUPPORT TUBE.

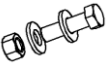

PARTS CODE	PART	QTY
20		3
25		6

PARTS CODE	PART	QTY
25A		6
27		6

STEP 4 : INSTALL REAR COVER PANEL.

- Lift up (#35) cover panel, starting from the center point of the frame (highest ridge point) use ropes (#33) through the grommets to tie the panel to the truss firmly. All grommets need to be tied to the frame as shown.

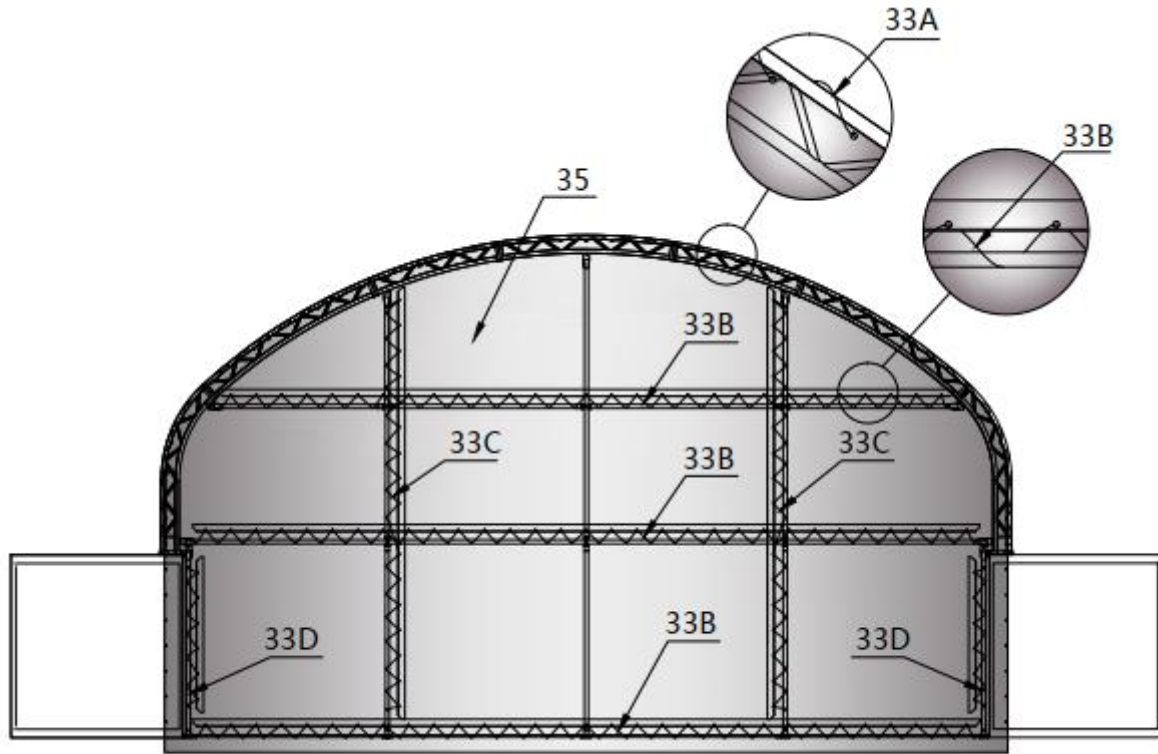

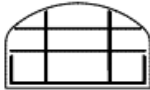
PARTS CODE	PART	QTY
35		1

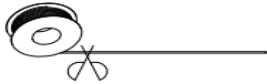
ROPE SHEAR SIZE		
33		Qty
A	13m	2
B	16m	3
C	9m	2
D	4m	2

AFTER THE INSTALLATION

Walk around and inspect the shelter periodically to make sure all components are still firmly secured and the whole shelter is well supported. Check all bolts and nuts as well as all connection points to make sure they are all in good position. Check the base plates, adjust the ropes and tie downs if required and clean the cover regularly.

Snow accumulating on the fabric cover must be removed as soon as possible. If snow becomes solid ice on the cover, it will increase the weight on the roof and may collapse the shelter or reduce the life span.

Keep the shelter on a dry ground most of the time. Do not keep the fabric dirt skirt under water all the time, otherwise the fabric will deteriorate.

We strongly recommend you remove any snow from the roof immediately. Do not leave any snow load on the roof overnight. Keep 3 feet of clearance on all sides at all times. Do not allow snow to accumulate and pile up on the sides of the building. Otherwise the pressure from the sides will push inwards and could lead to a collapse.