

40' X 60' DUAL TRUSS STORAGE SHELTER

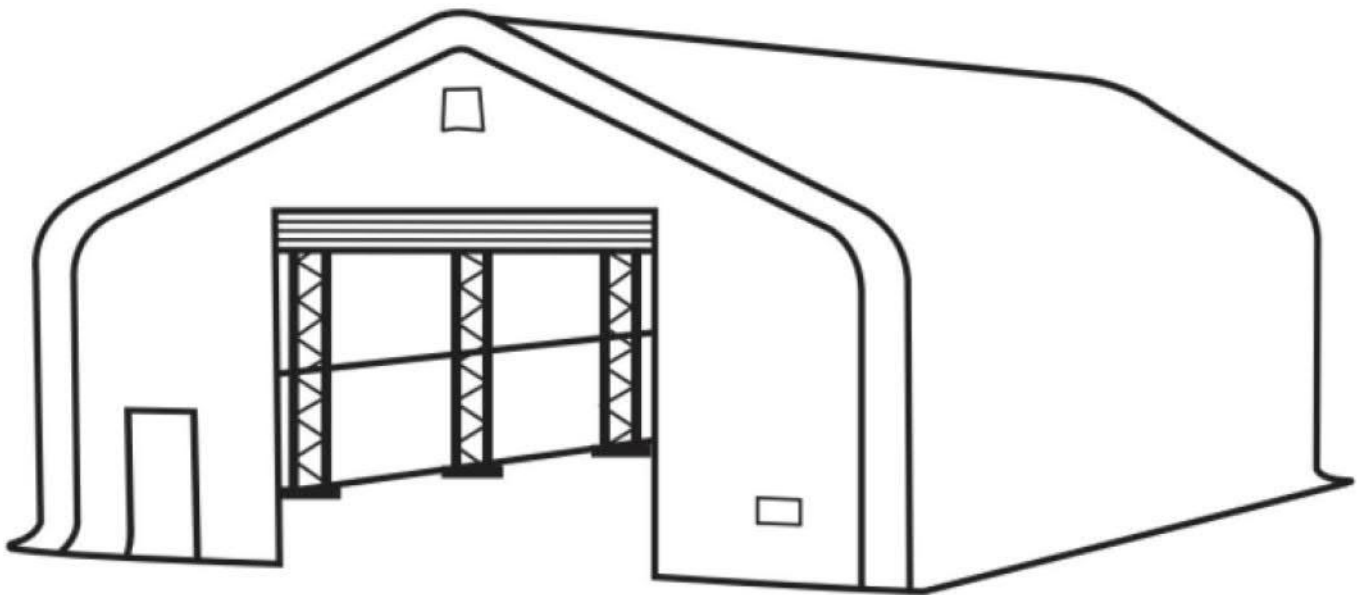

- Please read and understand the product manual completely before assembly
- Check against the parts list to make sure all parts are received
- Wear proper safety goggles or other protective gears while in assembly
- Do not return the product to dealer. They are not equipped to handle your requests.

Missing parts or have questions on assembly?
Please call: 1-877-761-2819 or email: cs@tmgindustrial.com

MAIN SPECIFICATIONS :

- Assembly size : W12.2 x L18 x H6.4 (m) / 40 x 59 x 21 (ft)
- Outside width : 12.2 m / 40ft, inside width : 11.4 m / 37.4ft, length : 18 m / 59 ft
- Ridge peak height : 6.4 m / 21 ft
- Peak clearance height : 5.8 m / 19 ft
- Front roll up door : 4.6 x 4.7 (m) / 15 x 15.4 (ft)
- Rear roll up door : 6 x 4.2 (m) / 19.7 x 13.8 (ft) (wider door side)
- Shoulder wall clearance height : 3.5 m / 11.5 ft

CONCRETE FOUNDATION SIZE SEE BELOW FIGURE.

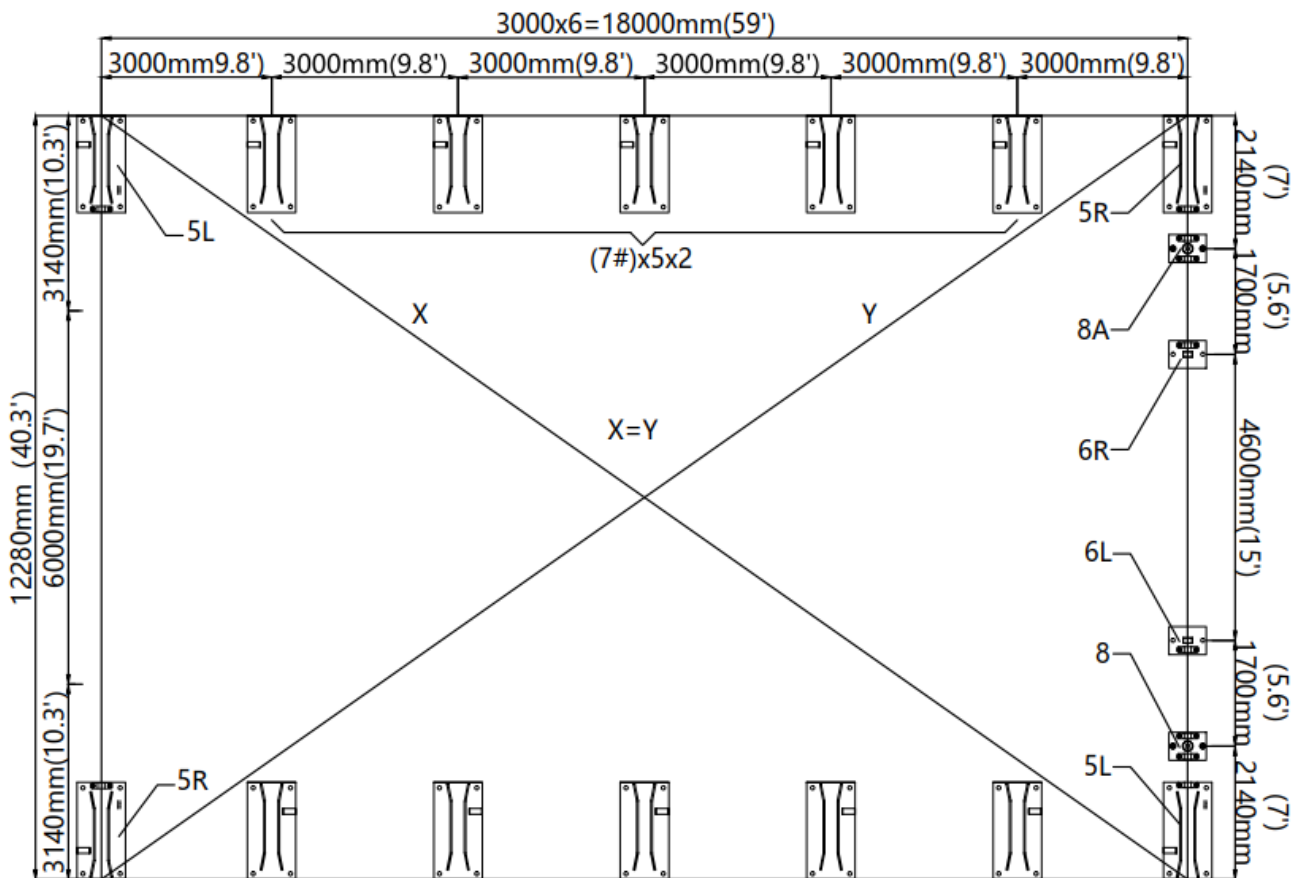

PRIOR TO ASSEMBLY

Please read the instructions carefully before installation. It is very important to follow your local safety regulations and industry standards during installation. Regulations may include but are not limited to:

- Safety helmets, protective eyewear, and clothing
- Safety harnesses for all elevated workers
- Proper ladder, cage, and safety operation

Check all components and parts before installation. All parts are marked with a part number, please refer to the parts list to make sure you have all parts.

Choose a day with low or no wind to install, assembly is hard in heavy wind. Do not make any alterations to the structure. Do not hang any weights on the frame during installation, including parts. We are not responsible for any damages or injuries caused by inappropriate installation, unauthorized modifications or extreme weather.

This building is not intended for human occupancy.

It is recommended to tape or add foam/rubber on the frame where joints connect and where it touches the cover. This will help extend the life span of the cover.

Read the following item list carefully and count the number of items to ensure that all parts are included prior to setup.

INSTALLATION STEPS





STEP 1 : REVIEW THE WHOLE STRUCTURE AND CHOOSE THE PROPER INSTALLATION SITE.







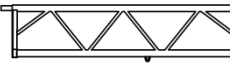



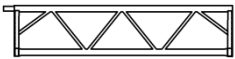
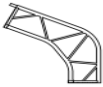

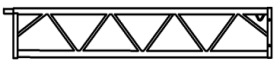
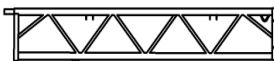



Choose a solid flat level ground area to set up the building. Do not install the building on soft ground, wetland, uneven surfaces, sloped surfaces, or on top of structures that are not rated to hold its weight.

We strongly recommend that you put the containers on hard foundations before installing the shelter.



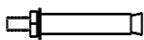



Be aware of the surrounding area. Do not set up the building near snowdrifts, open flames or exposed electrical wires. Do not keep heat sources near the fabric cover. Keep the building surroundings clear at all times.



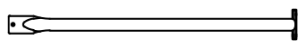
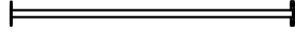
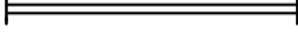

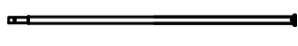
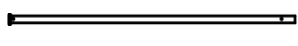
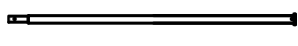
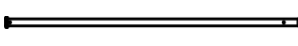
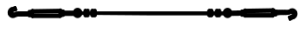
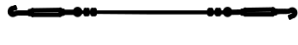
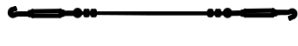
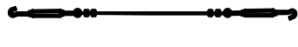



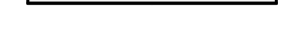





Check the parts list below to make sure all parts are received prior to assembly.

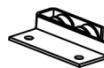

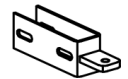

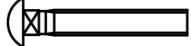

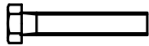
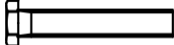

TMG-DT4061 PART LIST					
PARTS CODE	GRAPHICAL	DESCRIPTION	LENGTH	QTY	BOX
1		Peak arch tube (for 5 middle trusses)	L2550mm	5	B
1A		Peak arch tube (for front and rear truss)	L2550mm	2	B
2		Upper rafter tube (for middle truss)	L2113mm	10	B
2A		Up and low rafter tube (for front and rear truss)	L2113mm	8	B

2B		Lower rafter tube (for middle truss)	L2113mm	10	B
3		Shoulder tube (for middle truss)	L1987mm	10	A
3A		Shoulder tube (front and rear truss)	L1987mm	4	A
4		Sidewall tube (middle truss)	L2758mm	10	A
4A		Sidewall Tube (left and right for front truss and left for rear truss)	L2758mm	3	A
4B		Sidewall tube (right for rear truss)	L2758mm	1	A
5		Roof purl in (horizontal tube)	L3040mm	54	A
5L		Base plate for front and rear truss left corners	L520xW260mm	2	B
5R		Base plate for front and rear truss right corners	L520xW260mm	2	B
6		Left base plate of rear door frame	L200xW150mm	1	B
6L		Left base plate of front door frame	L200xW150mm	1	B
6R		Right base plate of front and rear door frame	L200xW150mm	2	B
7		Base plates for middle truss	L480xW260mm	10	B
7A		Ratchets	3T	42	B
7B		Expansion bolts mm	φ16x150mm	68	B
8		Front door left column base plate	L200xW150mm	1	B
8A		Front door right column base plate	L200xW150mm	1	B
9L		Front vertical door rail (left side upper part)	L2515mm	1	A

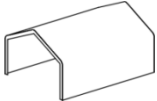
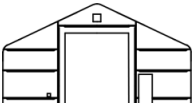
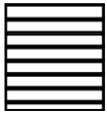
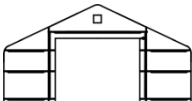
9R		Front vertical door rail (right side upper part)	L2515mm	1	A
10		Left lower vertical tubes for front trusses	L2180mm	1	B
10A		Right lower vertical tubes for front trusses	L2180mm	1	B
10B		Upper vertical tubes for front truss(connect to #10 and #10A)	L1875mm	2	B
10L		Front and rear vertical door rail (left side lower part)	L2255mm	2	B
10R		Front and rear vertical door rail(right side lower part)	L2255mm	2	B
11L		Rear vertical door rail (left side upper part)	L2190mm	1	A
11R		Rear vertical door rail (right side upper part)	L2190mm	1	A
12		Front door cross tubes (left and right)	L1664mm	4	B
12A		Front door upper crossing tubes (connect #12 left and right)	L1513mm	2	B
12B		Front door lower crossing tubes (connect #12 left and right)	L1639mm	2	B
12C		Rear truss upper cross tubes (left and right)	L2493mm	2	B
12D		Rear truss lower cross tubes (left and right)	L2646mm	2	A
13		Front door cross beam(left)	L2289mm	1	A
13A		Front door cross beam (right)	L2289mm	1	A
13B		Front door center vertical supporting rod for cross beam	L1097mm	1	B
13C		Rear door cross beam (left)	L2989mm	1	A
13D		Rear door cross beam (right)	L2987mm	1	A

13E		Rear door center vertical supporting rod for cross beam	L1422mm	1	B
14		Front door hand winch crossing tube	L1660mm	1	B
14A		Rear door hand winch cross tube	L2663mm	1	A
15		Tarp cover tension tubes on both sides	L1993mm	18	B
15A		Tarp cover tension tubes on both sides (shorter tube, can be on either end)	L700mm	2	B
16		Front roll up door dropping tubes (to connect #16A)	L2355mm	7	A
16A		Front roll up door dropping tubes (to connect #16)	L2353mm	7	A
16B		Rear roll up door dropping tubes (to connect #16C)	L3060mm	7	A
16C		Rear roll up door dropping tubes (to connect #16B)	L3058mm	7	A
17		Steel tension cables	L4170mm	16	B
17A		Steel tension cables	L3680mm	8	B
17B		Steel tension cables	L3340mm	8	B
17C		Steel tension cables	L3440mm	8	B
18		Front truss left steel cables	L3150mm	1	B
18A		Front truss right steel cables	L4180mm	1	B
18B		Rear truss left and right steel cables	L3700mm	2	B
18C		Middle truss crossing steel tension cables	L4100mm	5	B
19		Front fabric panel tension tubes	L1610mm	4	B

20		Back fabric panel tension tubes	L2630mm	2	B
21		Tie down straps (for #7A and front and rear arches)	W38xL800mm	42	B
22		Cable connection plate	L91mm	32	B
22A		pressing plate	L2000mm	8	B
23		Roll up door hand winch	1200lb	2	B
23A		Wire rope for front door hand winch	φ4xL15m	1	B
23B		Wire rope for rear door hand winch	φ4xL14.2m	1	B
23C		Left pulley system for front and rear doors	L149mm	2	A
23D		Right pulley system for front and rear doors	L149mm	2	A
24		Front and rear vertical door rail connection plate	L240mm	4	B
24A		Front and rear vertical door rail end plate (float table to keep door rail straight)	L215mm	4	A
24B		Pipe clamps for front and rear vertical tubes to connect to truss frame	φ58mm	8	B
25		Tension tube end water plug	φ32mm	16	B
26		Self locking bolt and nuts	M10x80mm	63	B
27		Self locking bolt and nuts	M8x80mm	8	B
28		Hex bolt and nuts	M12x30mm	280	B
29		Hex bolt and nuts	M10x30mm	8	B

29A		Hex bolt and nuts	M10x50mm	8	B
30		Hex bolt and nuts	M10x60mm	44	B
31		Hex bolt and nuts	M10x80mm	24	B
32		Tension ropes (tie to front and back doors)	φ8xL160m	1 bundle	B
33		Roof fabric tarp cover	L21.12xW18.62 m	1	A
34		Front truss fabric tarp panel	L12.2xW6.55m	1	B
34A		Front roll up door fabric tarp panel	L4.82xW4.56m	1	B
35		Rear truss fabric tarp panel	L12200xW6556 m	1	B
35A		Rear roll up door fabric tarp panel	L5960xW4530m	1	B
36		Front and rear fabric tarp secure pin	φ6xL200mm	2	B
37		Plastic hose (in grooves at both ends of # 33)	φ25xL4000mm	10	A
37A		Connector (for connection #37)	φ25	8	B
38		Scratch resistant tape	L10m	3	B
39		tapping screw	M5x25mm	48	B

STEP 2 : BASEPLATE POSITIONING AND INSTALLATION.

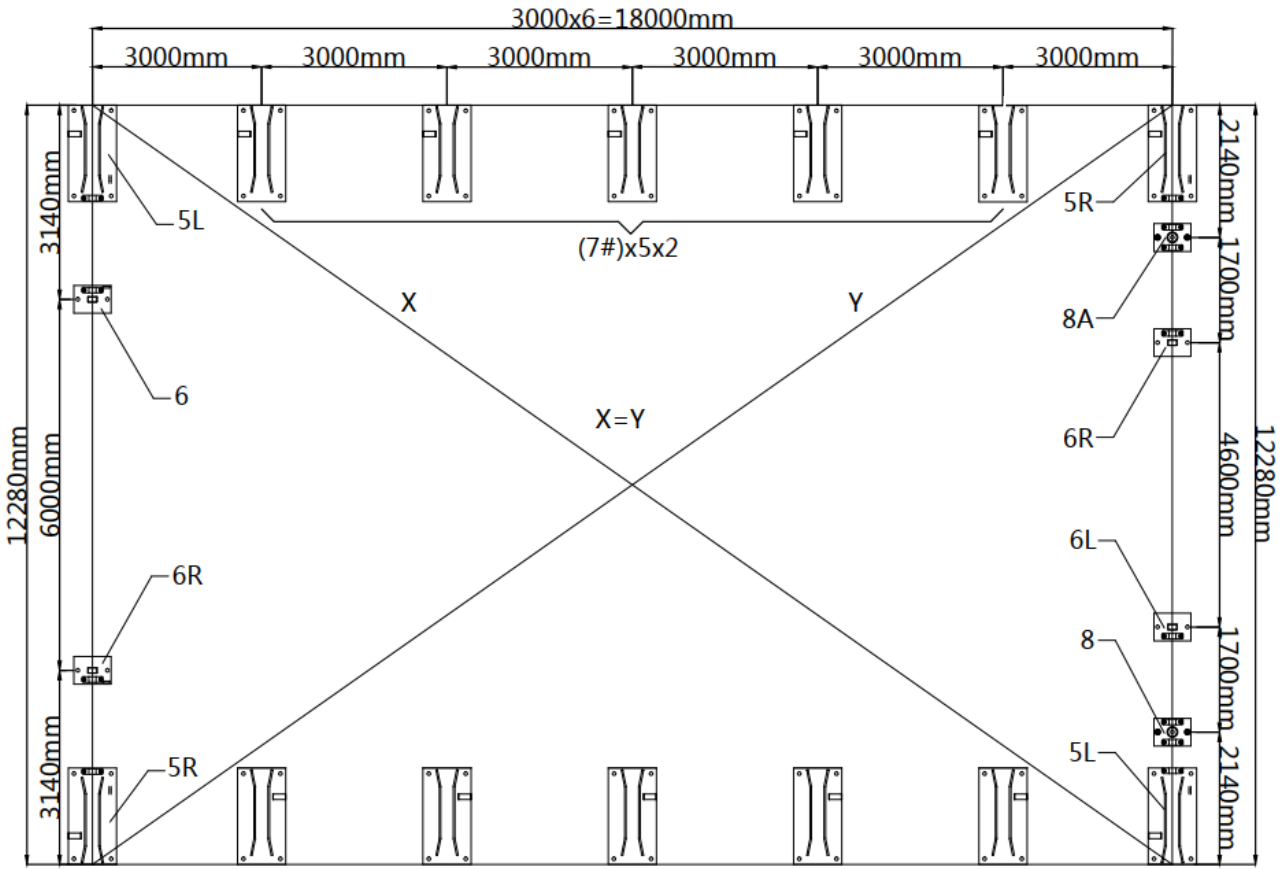



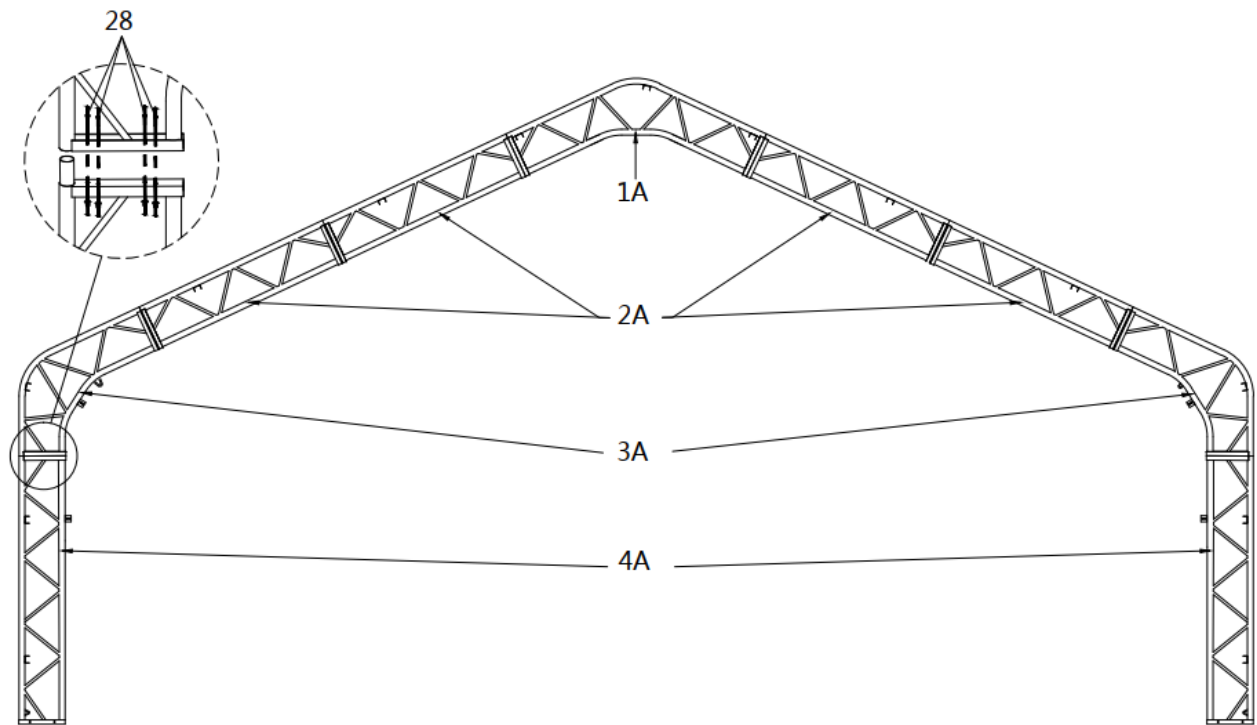

PARTS CODE	PART	QTY
5L		2
5R		2
6		1
6L		1
6R		2

PARTS CODE	PART	QTY
7		10
7B		68
8		1
8A		1

STEP 3 : INSTALL THE FRONT TRUSS.

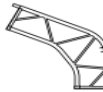

PARTS CODE	PART	QTY
1A		1
2A		4
3A		2
4A		2
28		32

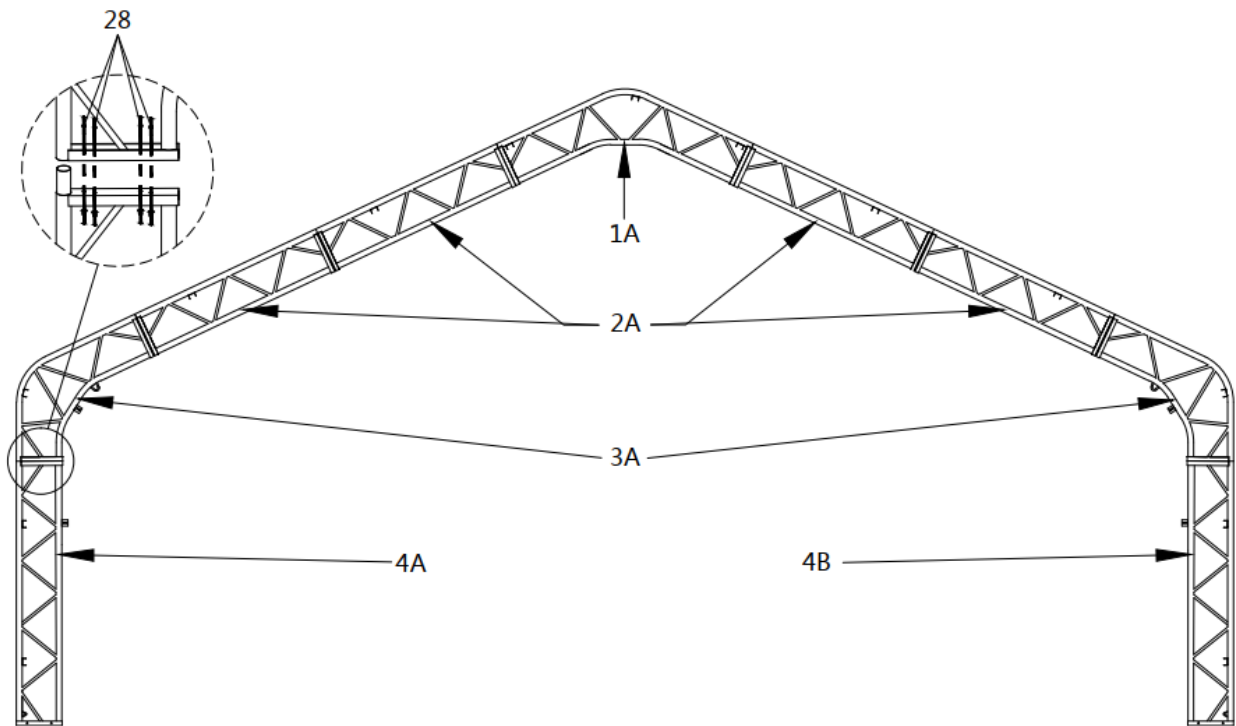

STEP 4 : INSTALL THE REAR TRUSS.

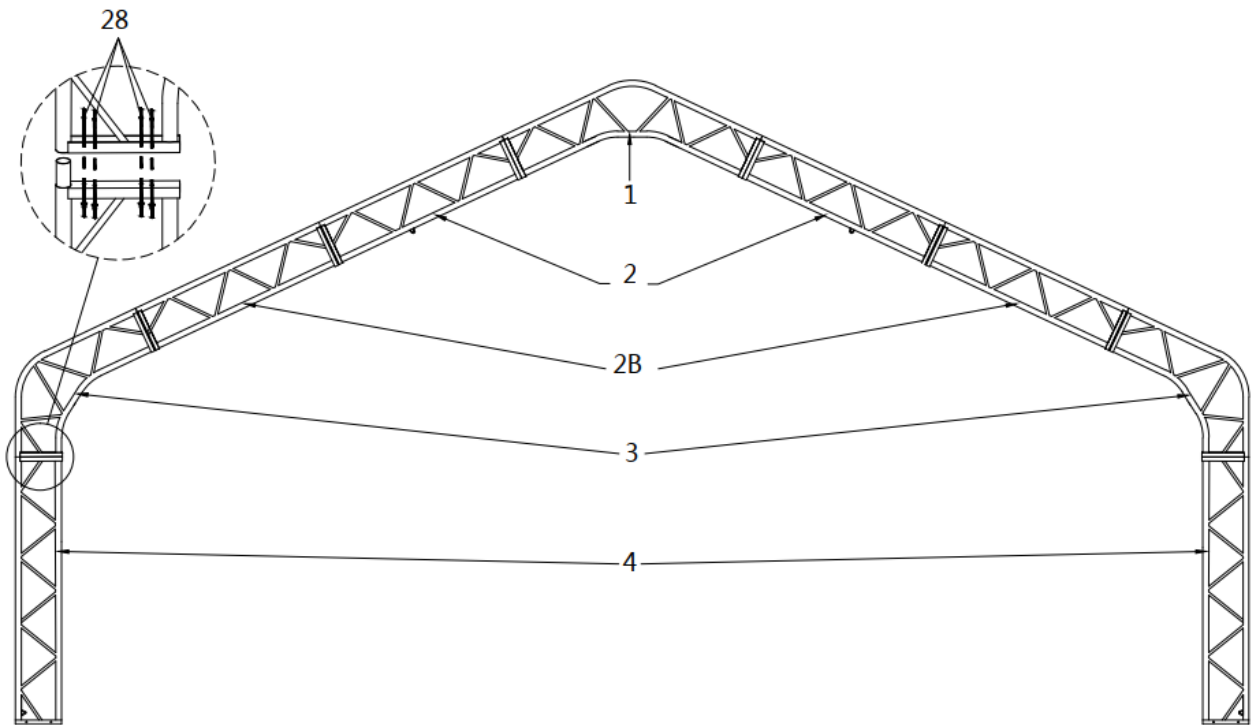

PARTS CODE	PART	QTY
1A		1
2A		4
3A		2
4A		1
4B		1
28		32

STEP 5 : INSTALL INTERMEDIATE TRUSS.

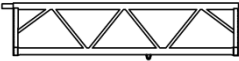
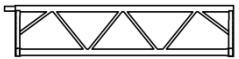
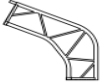

PARTS CODE	PART	QTY
1		1x5
2		2x5
2B		2x5
3		2x5
4		2x5
28		32x5

STEP 6 : WRAP (#38) AROUND THE SHARP POINTS OF THE JOINT TO AVOID FRICTION BETWEEN THE FABRIC AND THE INTERFACE.

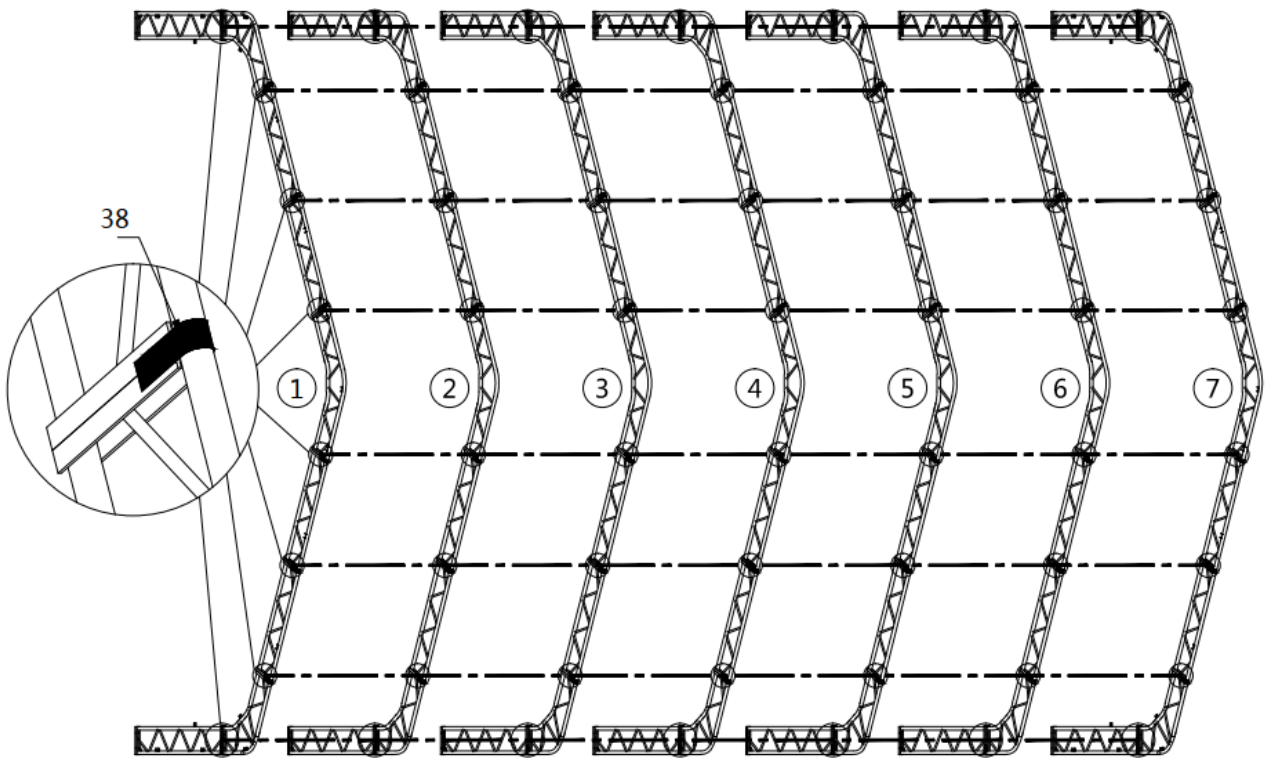

PARTS CODE	PART	QTY
38		3

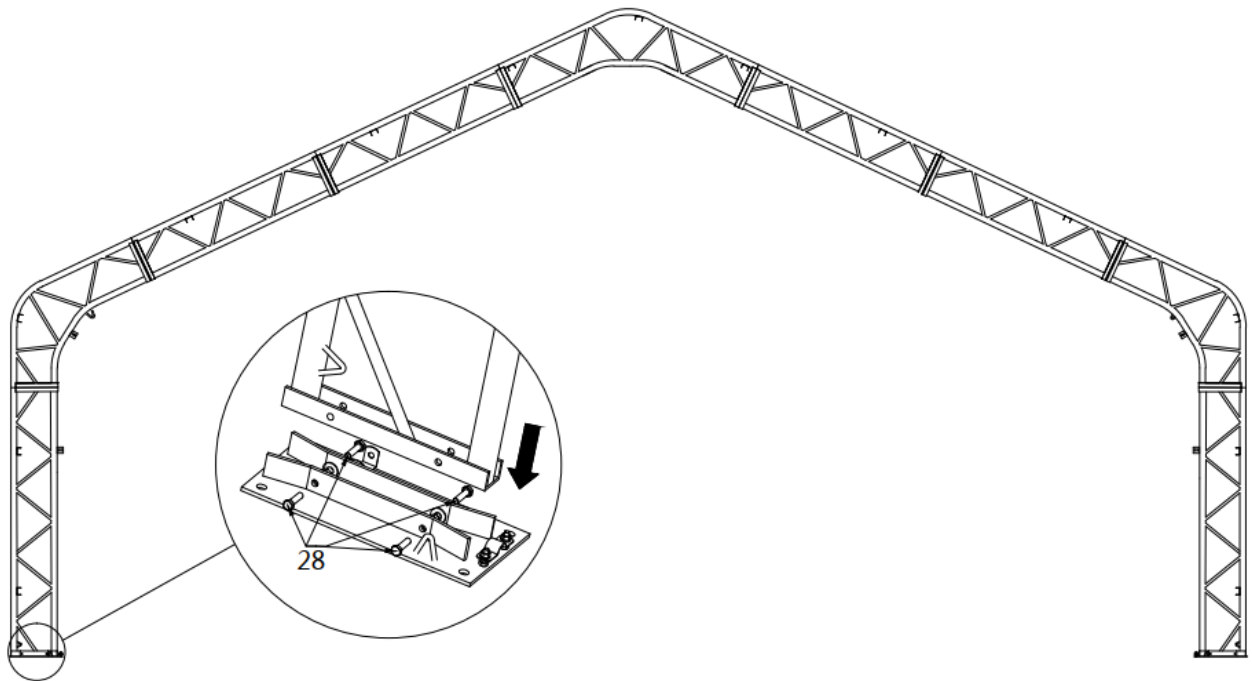

STEP 7 : INSTALL THE FRONT TRUSS.



PARTS CODE	PART	QTY
28		8

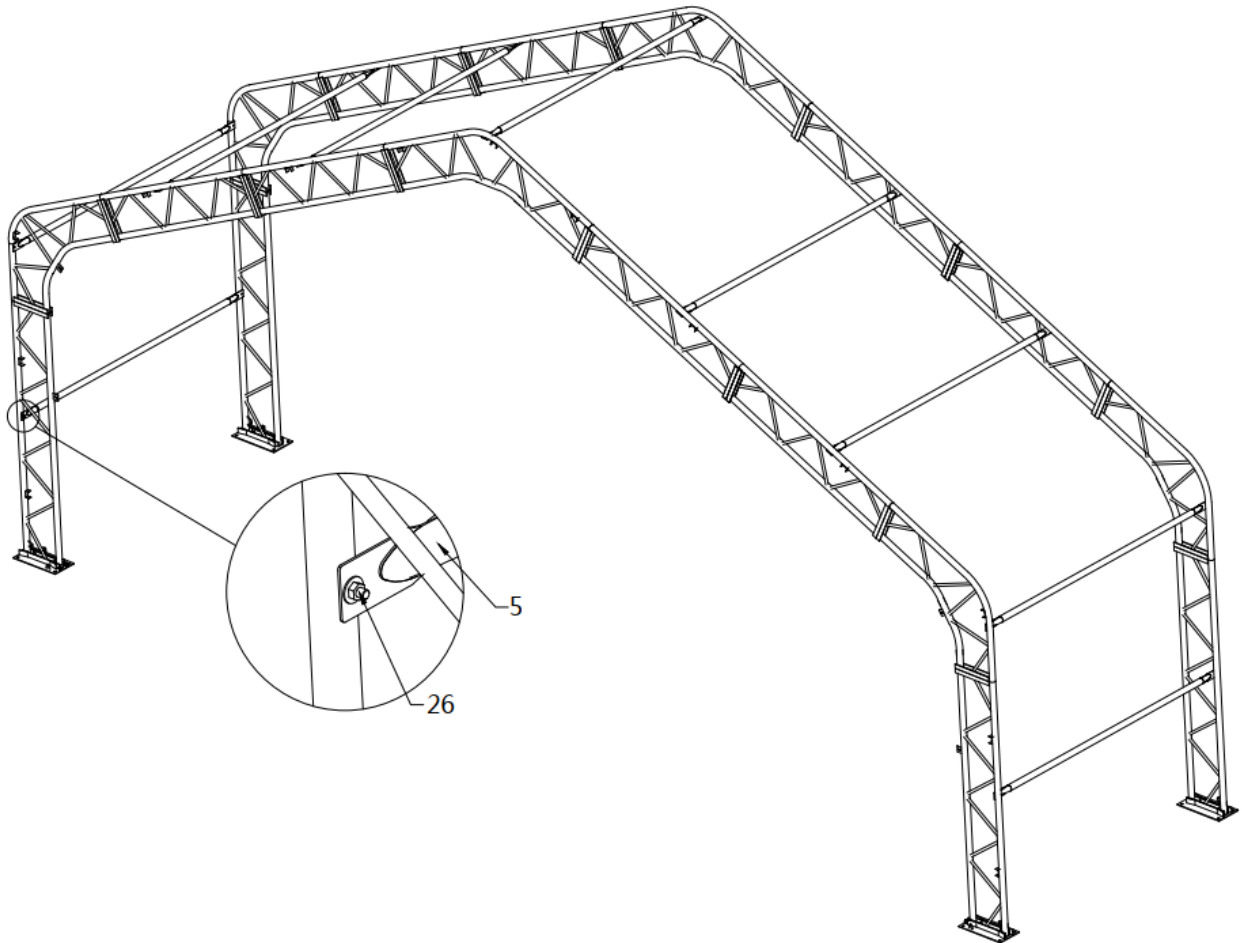

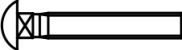
STEP 8 : PUT UP THE 2ND TRUSS, AND CONNECT ALL PURLINS (#5) BETWEEN 1ST AND 2ND RUSS WITH BOLTS.



PARTS CODE	PART	QTY
5		9
26		18
28		8

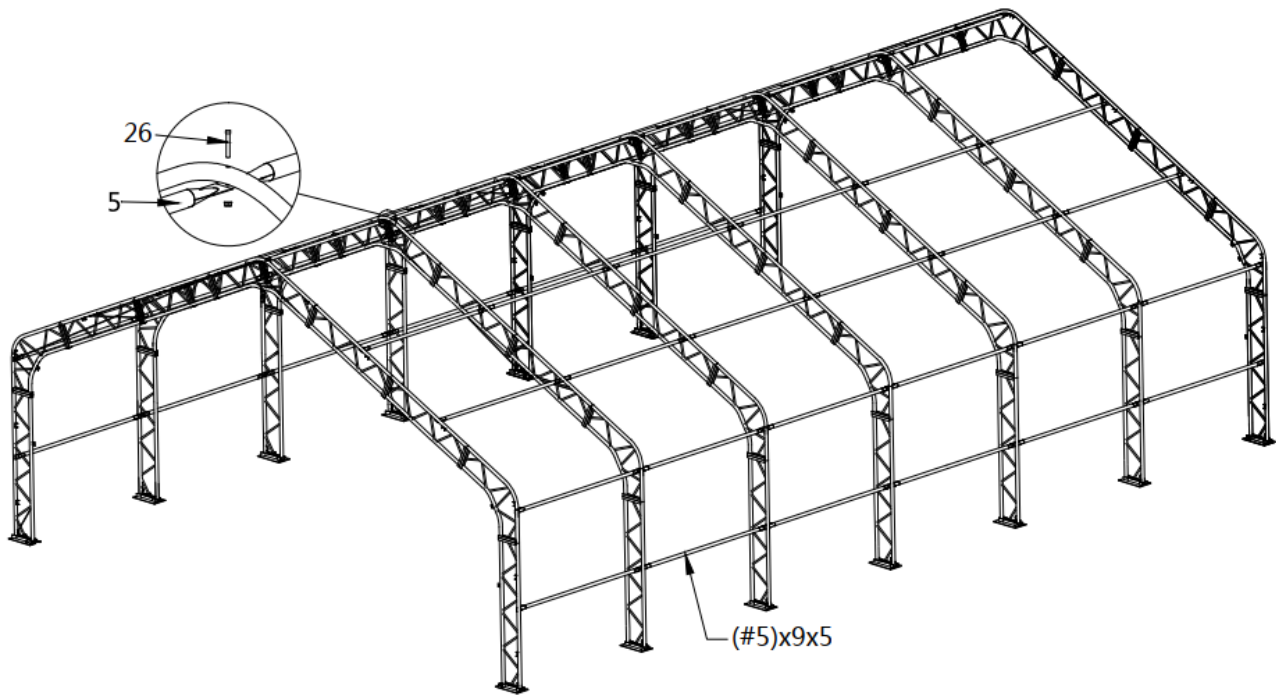

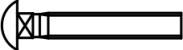



STEP 9 : INSTALL ALL OTHER TRUSSES. (FROM 3RD TRUSS TO 7TH TRUSS)

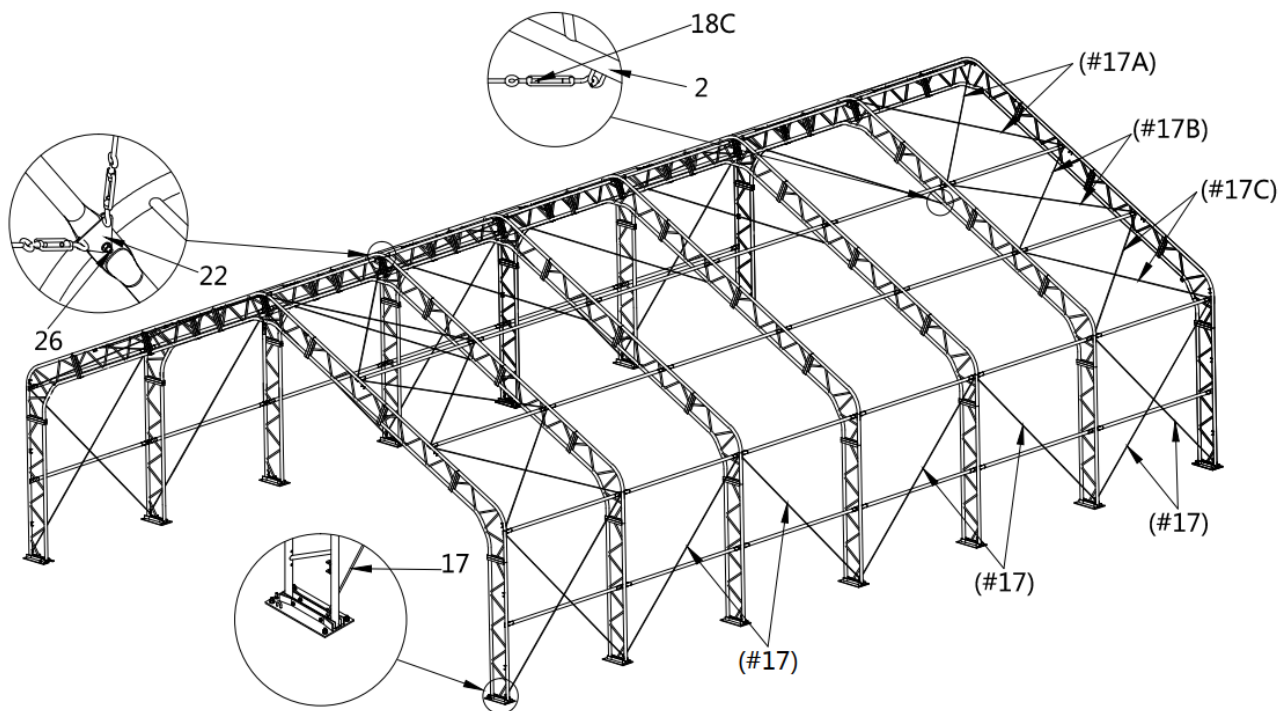

PARTS CODE	PART	QTY
5		9x5
26		9x5
28		8x5

STEP 10 : TENSION CABLE INSTALLATION.



PARTS CODE	PART	QTY
17		16
17A		8
17B		8
17C		8
18C		5
22		32

STEP 11 : FRONT TRUSSES TO COMPLETE.

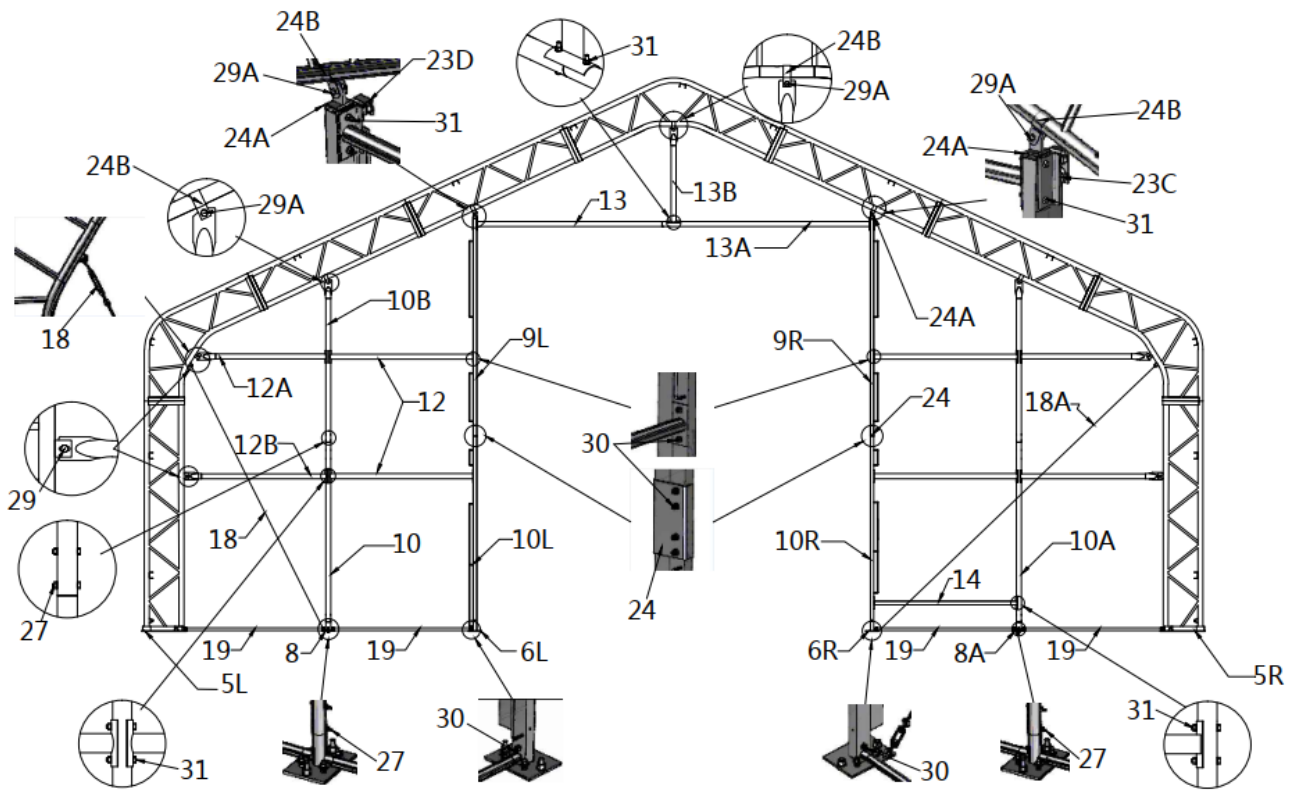

PARTS CODE	PART	QTY
9L		1
9R		1
10		1
10A		1
10B		2
10L		1
10R		1
12		4
12A		2
12B		2
13		1
13A		1
13B		1
14		1

PARTS CODE	PART	QTY
18		1
18A		1
19		4
23C		1
23D		1
24		2
24A		2
24B		5
27		8
29		4
29A		5
30		20
31		16

STEP 12 : TRUSS AFTER COMPLETION.

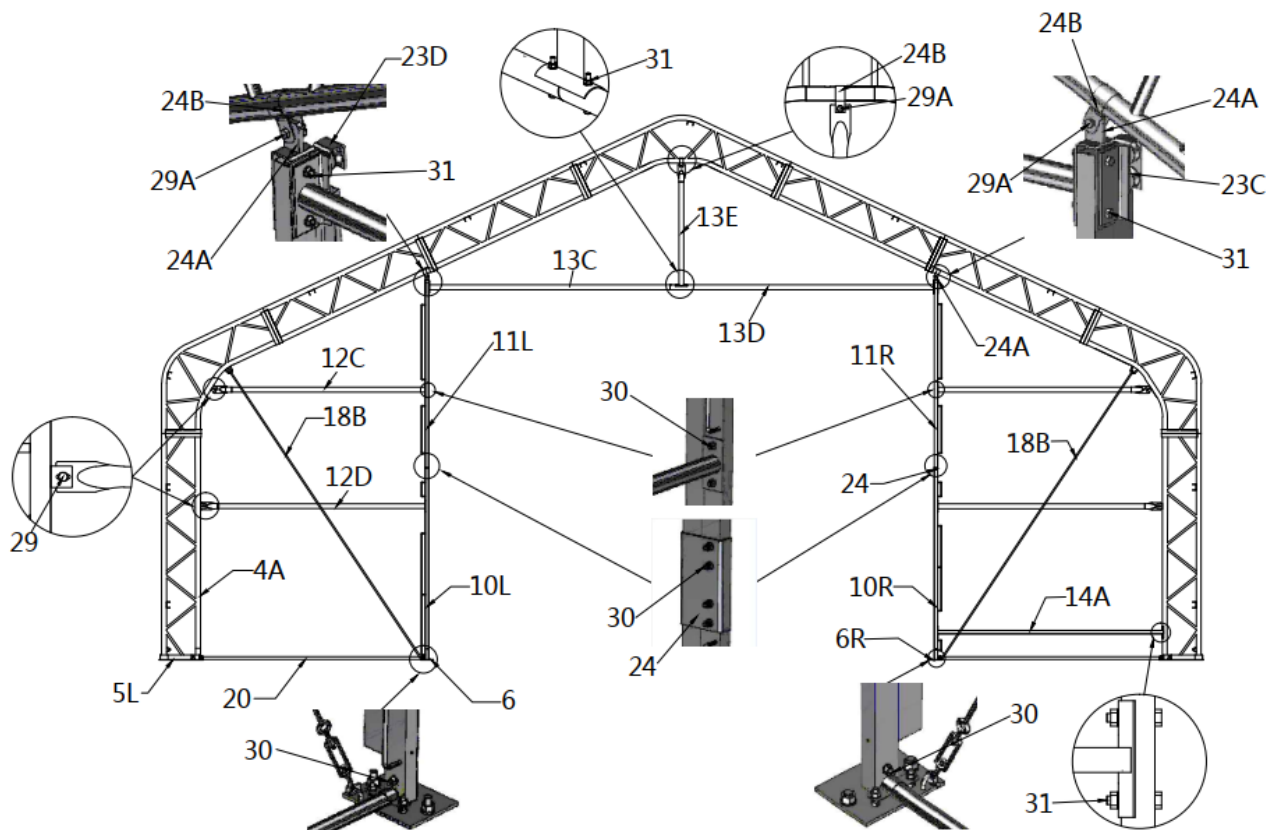

PARTS CODE	PART	QTY
10L		1
10R		1
11L		1
11R		1
12C		2
12D		2
13C		1
13D		1
13E		1
14A		1
18B		2

PARTS CODE	PART	QTY
20		2
23C		1
23D		1
24		2
24A		2
24B		3
29		4
29A		3
30		20
31		8

STEP 13 : FRONT TRUSS FABRIC PANEL INSTALLATION.

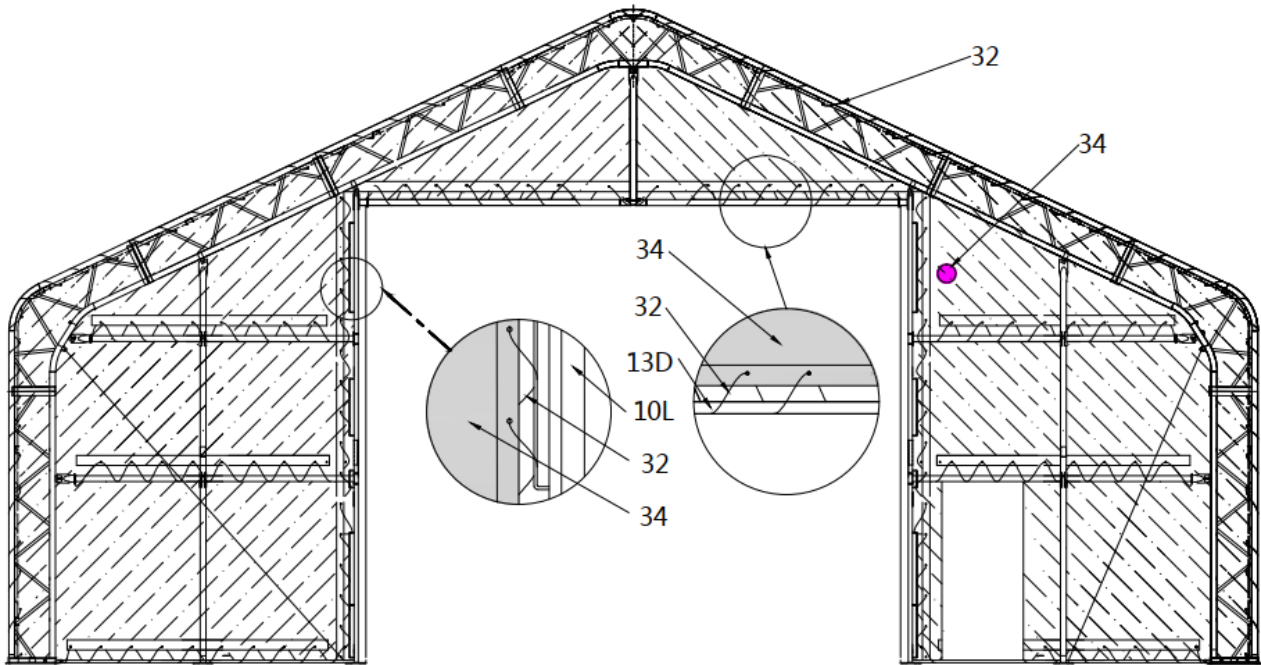

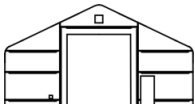
PARTS CODE	PART	QTY
32		1
34		1

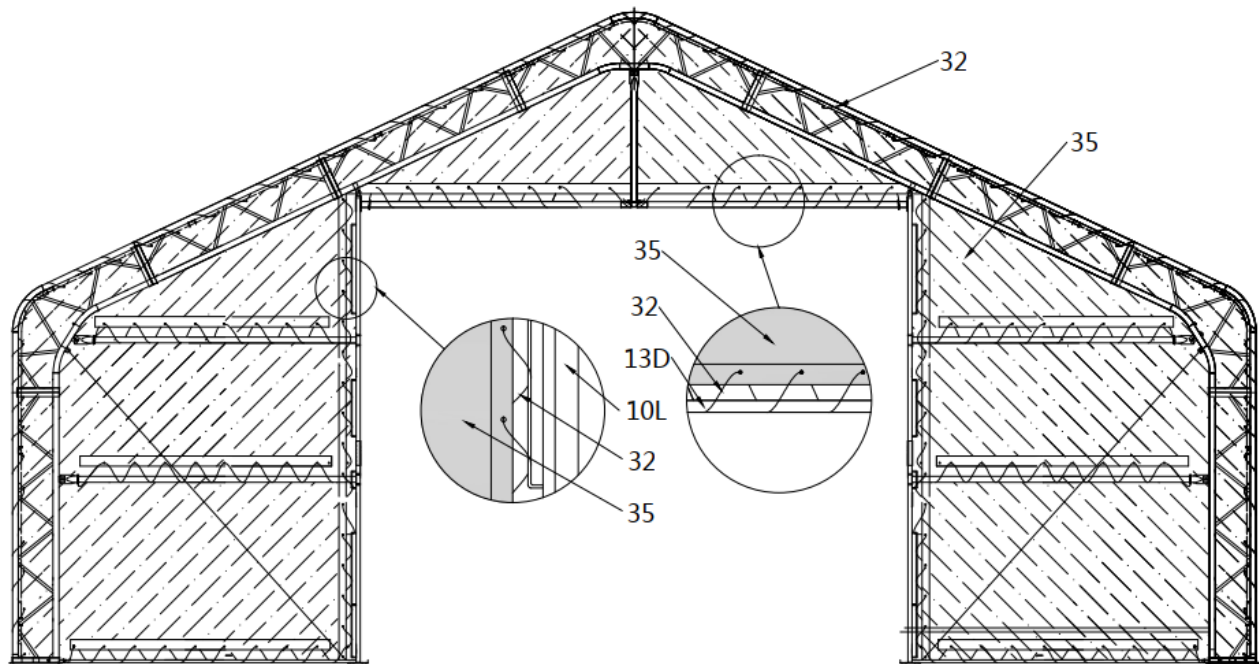

STEP 14 : REAR TRUSS FABRIC PANEL INSTALLATION.

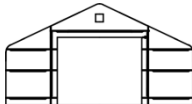

PARTS CODE	PART	QTY
32		1
35		1

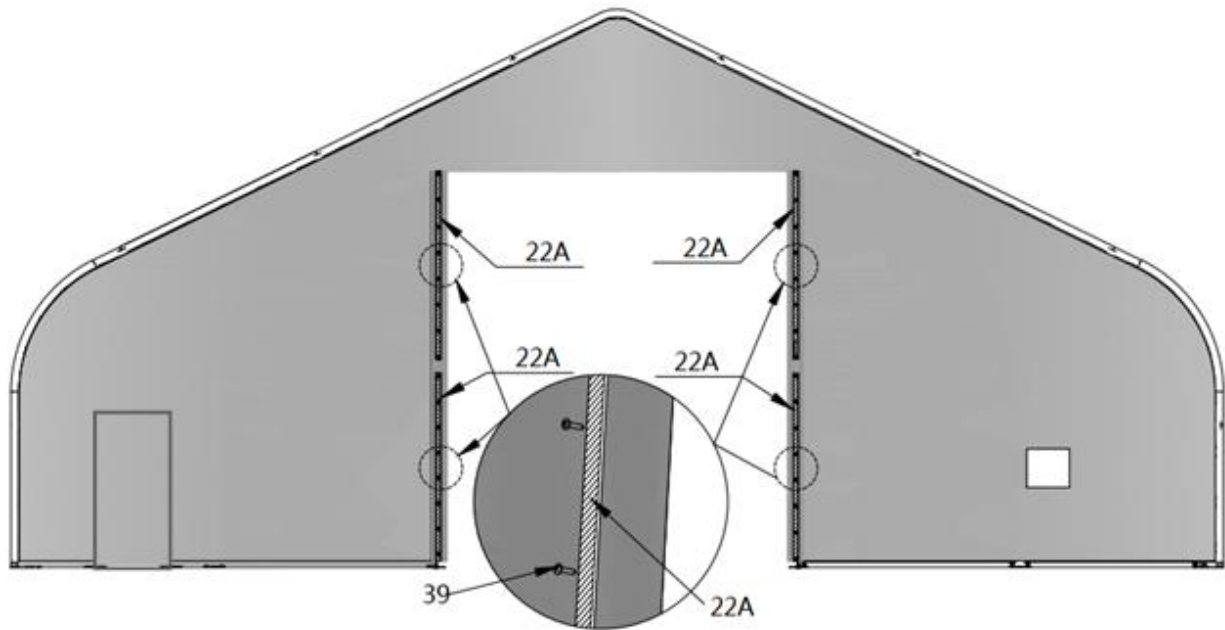





STEP 15 : INSTALL THE FRONT DOOR METAL STRIP. (THE FRONT AND REAR MOUNTING METHODS ARE THE SAME)

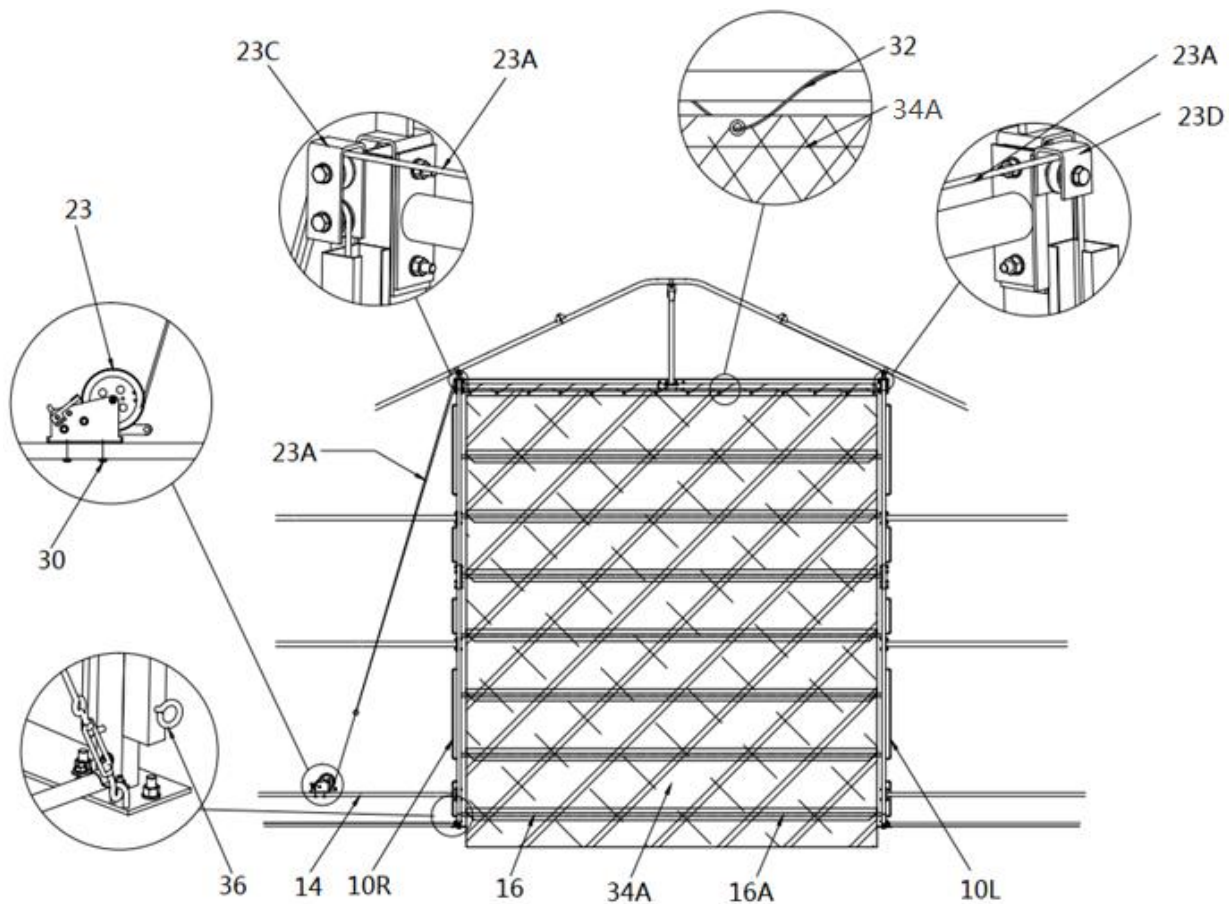

PARTS CODE	PART	QTY
22A		4x2
39		24x2



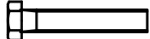
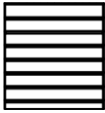



STEP 16 : INSTALL THE FRONT MECHANICAL ROLLING SHUTTER DOOR.

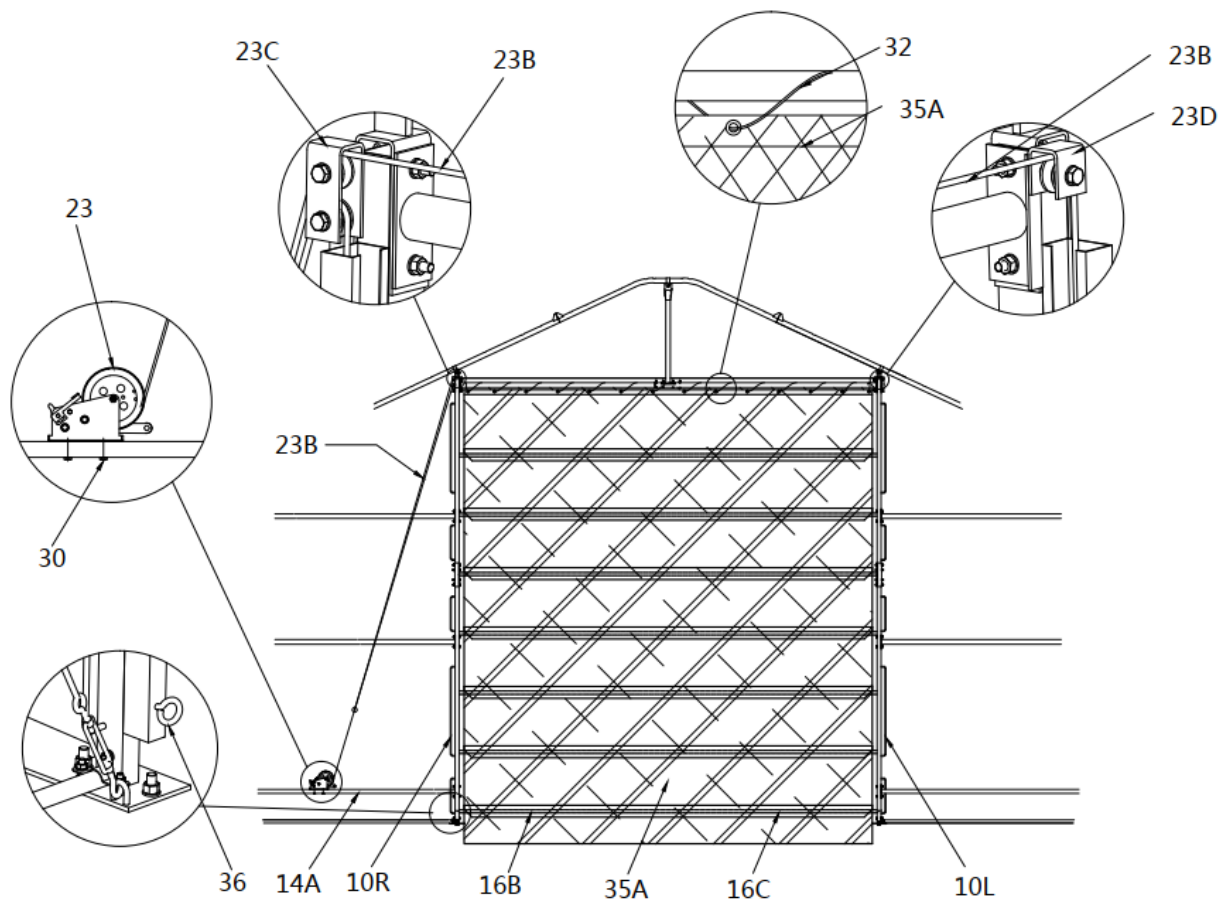

PARTS CODE	PART	QTY
16		7
16A		7
23		1
23A		1
30		2
34A		1
36		1

STEP 17 : INSTALL THE REAR MECHANICAL ROLLING SHUTTER DOOR.

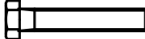

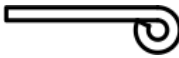
PARTS CODE	PART	QTY
16B		7
16C		7
23		1
23B		1
30		2
35A		1
36		1

STEP 18 : INSTALL ROOF COVER.

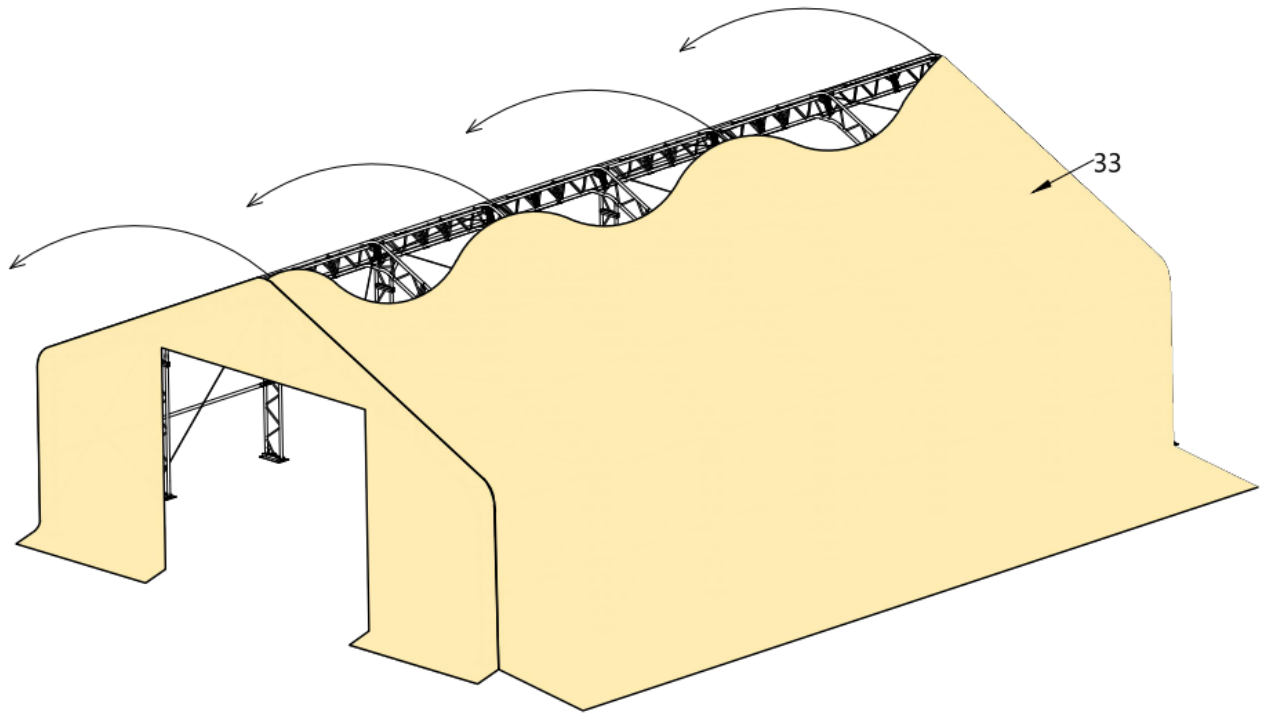

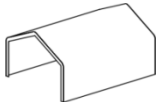
PARTS CODE	PART	QTY
33		1

STEP 19 : TOP CLOTH TENSIONING.

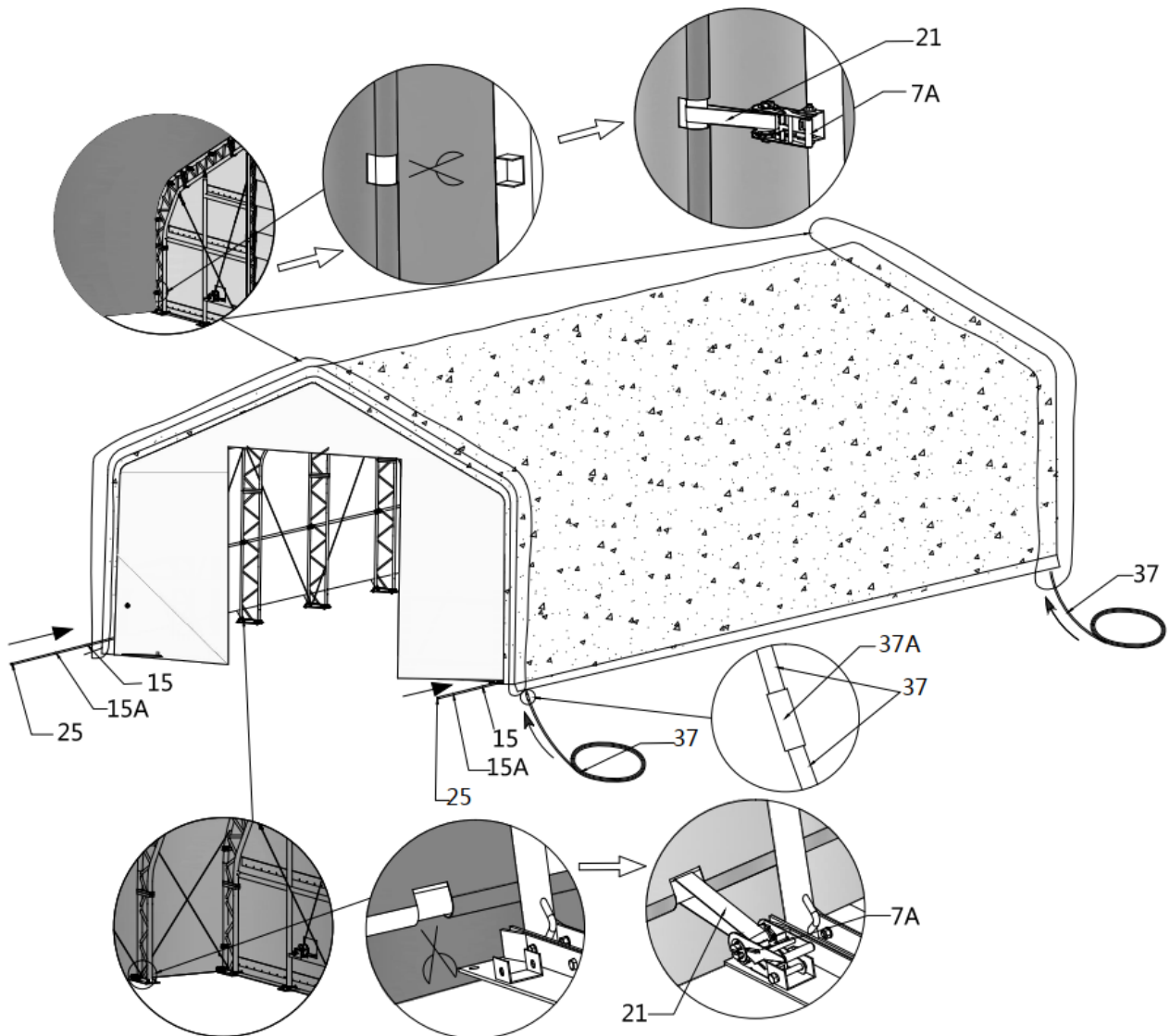

PARTS CODE	PART	QTY
7A		42
15		18
15A		2
21		42

PARTS CODE	PART	QTY
25		16
37		10
37A		8

STEP 20 : TIGHTEN ROOF COVER ON FRONT AND REAR TRUSS FRAMES.

- The roof cover must be stretched and tied to the front and rear truss by rope #34 going through flap grommets on the cover. Start from the top center of the truss and go toward both side on each end. Add or cut the rope as needed.
- Pull and stretch the cover enough only to take wrinkles out. Repeat for the reartruss. Do not over stretch to rip off the grommets.
- After the cover is placed and adjusted evenly across the grommet flap, go back and re-adjust all ratchets along the side edges. At this point, the roof cover should be pulled and stretched enough to take all wrinkles out. It is required to repeat this step 2-3 weeks after the installation is completed and the cover has stretched out over a certain time period on the frame.

AFTER THE INSTALLATION

Walk around and inspect the building periodically to make sure all components are still firmly secured and the whole building is well supported. Check all bolts and nuts as well as all connection points to make sure they are all in good position. Check the base plates, adjust the ropes and tie downs if required and clean the cover regularly.

Snow accumulating on the fabric cover must be removed as soon as possible. If snow becomes solid ice on the cover, it will increase the weight on the roof and collapse the building or reduce the life span eventually.

Keep the building on a dry ground most of the time. Do not keep the fabric dirt skirt under water all the time, otherwise the fabric will deteriorate.

We strongly recommend you remove any snow from the roof immediately. Do not leave any snow load on the roof overnight. Keep 3 feet of clearance on all sides at all times. Do not allow snow to accumulate and pile up on the sides of the building. Otherwise the push from the sides toward inside will make the building collapsed at some point.