

20' X 40' DUAL TRUSS PRO SERIES STORAGE SHELTER

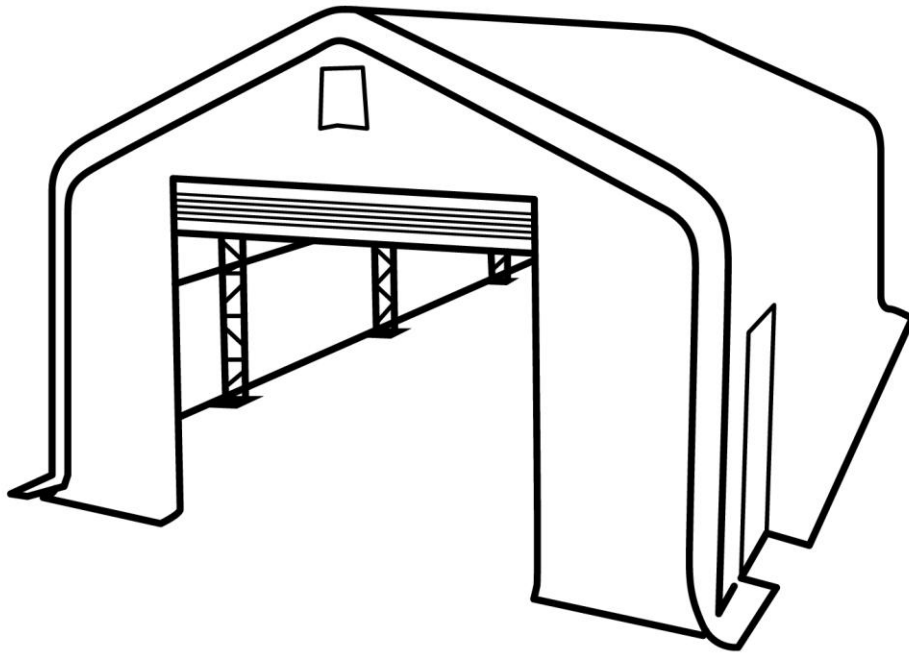

- Please read and understand the product manual completely before assembly
- Check against the parts list to make sure all parts are received
- Wear proper safety goggles or other protective gears while in assembly
- Do not return the product to dealer. They are not equipped to handle your requests.

Missing parts or have questions on assembly?
Please call: 1-877-761-2819 or email: cs@tmgindustrial.com

MAIN SPECIFICATIONS :

- Assembly size : W6 x L12 x H4.5 (m) / 19.7 x 39.4 x 14.8 (ft)
- Ridge height : 4.5m / 14.8 ft
- Front and back door : 3.6 x 2.9 (m) / 11.8 x 9.5 (ft)
- Shoulder height : 3m / 9.9ft

CONCRETE FOUNDATION SIZE SEE BELOW FIGURE.

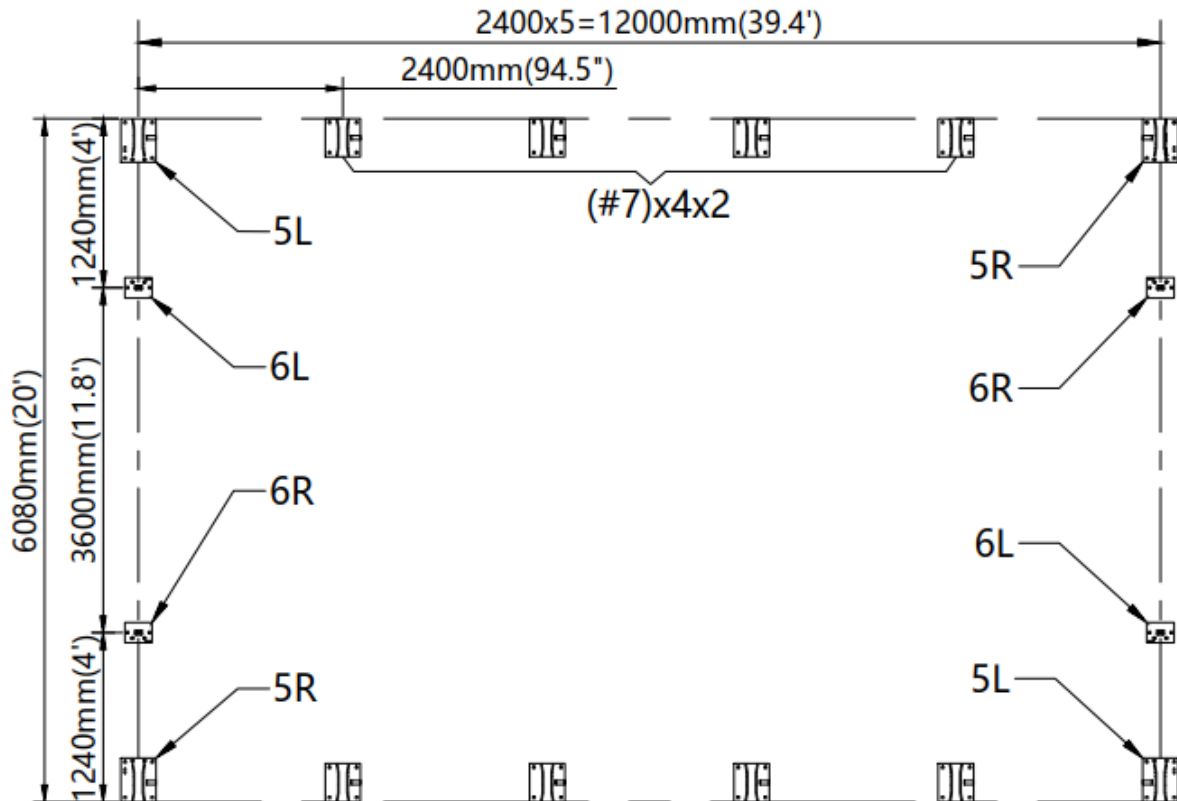

PRIOR TO ASSEMBLY

Please go through the whole instruction manual completely. It is very important to follow your local safety regulations and industry standards during installation. Regulations may include but are not limited to :

- Safety helmets, protective eyewear, and clothing
- Safety harnesses for all elevated workers
- Proper ladder, cage, and safety operation

Check all components and parts before installation. All parts are marked with a part number, please refer to the parts list to ensure you have all parts.

Choose a day with low or no wind to install, it is hard to assemble with heavy wind. Do not make any alterations to the structure. Do not hang any weight on the frame during installation, including parts. We are not responsible for any damages or injuries caused by inappropriate installation, unauthorized modifications or extreme weather.

This building is not intended for human occupancy.







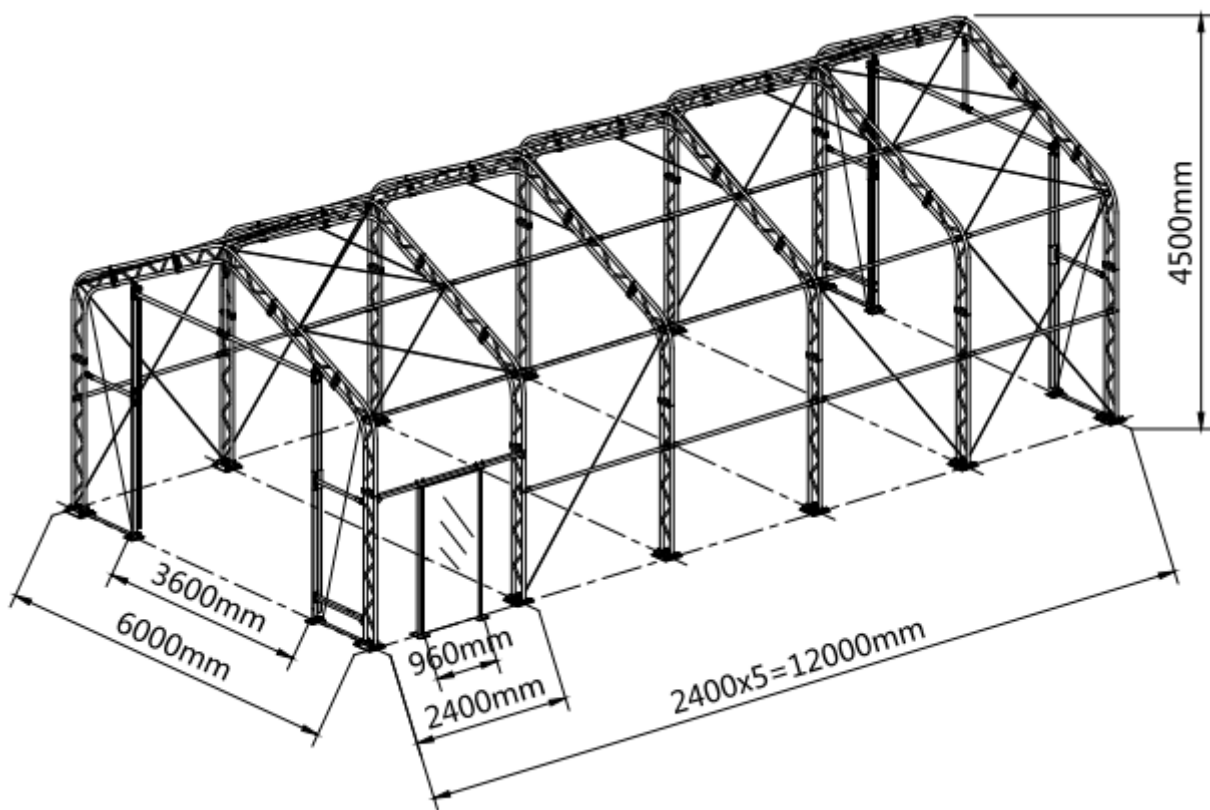

It is recommended to use heavy duty duct tapes to tape the tube connection joint spots to protect the cover from damage and worn. It will help to extend the cover life span.

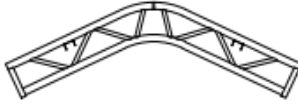
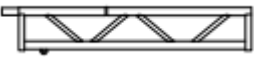
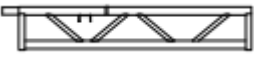



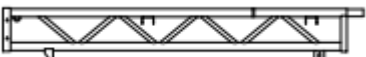
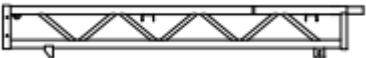
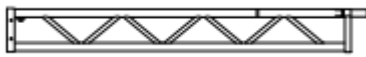

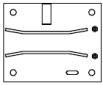
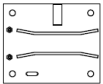



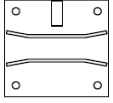

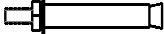

Check the parts list below to make sure all parts are received prior to assembly.

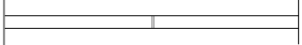
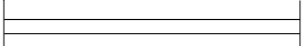

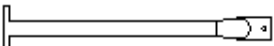

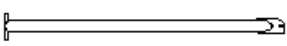



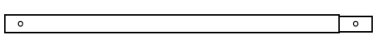

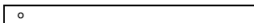
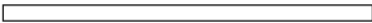







FRAME STRUCTURE DIAGRAM.











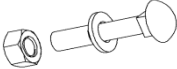
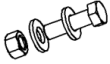
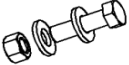
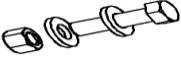

TMG-DT2031-PRO PART LIST

PARTS CODE	GRAPHICAL	DESCRIPTION	LENGTH	QTY
1		Peak arch tube (for middle trusses)	L2020mm	4
1A		Peak arch tube (for front and rear truss)	L2020mm	2
2		Upper rafter tube (for middle trusses)	L 1495mm	8
2A		Upper rafter tube (for front and rear truss)	L1495mm	4
3		Shoulder tube (for middle trusses)	L1707mm	8
3A		Shoulder tube (front and rear trusses)	L1707mm	4
4		Sidewall tube (middle trusses)	L2163mm	7
4A		Sidewall tube (front and rear left truss)	L2163mm	2
4B		Sidewall tube (rear right truss)	L2163mm	1
4C		Sidewall tube (front right truss)	L2163mm	1
4D		Sidewall tube (second right truss)	L2163mm	1
5		Roof purlin (horizontal tube)	L2440mm	34
5L		Baseplate for front and rear truss left corners	L320xW260mm	2
5R		Baseplate for front and rear truss right corners	L320xW260mm	2
6L		Left baseplate of front door frame	L200xW150mm	2

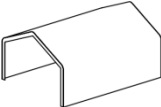
6R		Right baseplate of front door frame	L200xW150mm	2
7		Baseplates for middle truss	L280xW260mm	8
7A		Ratchets	L155mm	37
7B		Expansion bolts	φ16x150mm	60
8		Ceiling cross bar (front and rear truss)	L1748mm	2
9		Ceiling cross bar (front and rear truss)	L1898mm	2
9L		Front and rear vertical door rail (left side upper part)	L1465mm	2
9R		Front and rear vertical door rail (right side upper part)	L1465mm	2
9A		Side door left tube	L2027mm	1
9B		Side door right tube	L2027mm	1
9C		Side door	L2005xW925mm	1
10		Door center vertical supporting rod for cross beam	L930mm	2
10L		Front and rear vertical door rail (left side lower part)	L2015mm	2
10R		Front and rear vertical door rail (right side lower part)	L2015mm	2
11		Door frame horizontal tube (front and rear truss)	L940mm	4
11C		Side door upper tube	L2328mm	1
12		Bottom tension bar (front and rear truss)	L930mm	4
13		Door hand winch crossing tube	L944mm	2
14		Top cover tension tube (for both bottom sides)	L1993mm	11

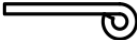
14A		Top cover tension tube (for both bottom sides)	L1970mm	2
14B		Top cover tension tube	L2450mm	1
15		Roll up door dropping tubes (to connect #16)	L1856mm	10
16		Roll up door dropping tubes (to connect #15)	L1859mm	10
17		Sidewall frame steel tension cables	φ6x3700mm	12
18		Ridge steel tension cables (front and rear trusses)	φ6x2800mm	16
19		Middle truss crossing steel tension cables	φ6x2m	4
20		Front and rear truss left and right steel cables	φ6x3m	4
21		Tie down straps (for #7A)	W38xL800mm	37
22		Cable connection plate	91mm	24
22A		Pressing plate	L2m	6
22B		Pressing plate	L1m	5
23		Roll up door hand winch	(3T)	2
23A		Wire rope for front and rear door hand winch	L10m	2
23B		Right pulley system for front and rear doors	L150mm	2
23C		Left pulley system for front and rear doors	L150mm	2
23D		Clip		6
24		Front and rear vertical door rail connection plate	L240mm	4
24A		Front and rear vertical door rail end plate (floatable to keep door rail straight)	L220mm	4

25		Tension tube end water plug	φ32	14
26		Tube clamps	φ48	6
27		Plastic hose (in grooves at both ends of #33)	φ25xL4m	7
27A		Connector (for connection #27)	φ25	6
28		Self locking bolt and nuts	M10x70mm	41
29		Strengthened bolt and nuts	M12x30mm	156
30		Hex bolt and nuts	M10x50mm	10
31		Hex bolt and nuts	M10x70mm	50
32		Braided rope (tie to front and back doors)	L100m	1
33		Roof fabric tarp cover	L13.3xW10.2m	1
34		Front and rear truss cover panel	L6xW4.7m	2
35		Front and rear roll up door cover panel	L3.55xW3.46m	2
36		Front and rear fabric tarp secure pin	200mm	2
37		Tapping screw	#12x25mm	76
38		Scratch resistant tape	10m	2

STEP 1 : BASE PLATE POSITIONING AND INSTALLATION.

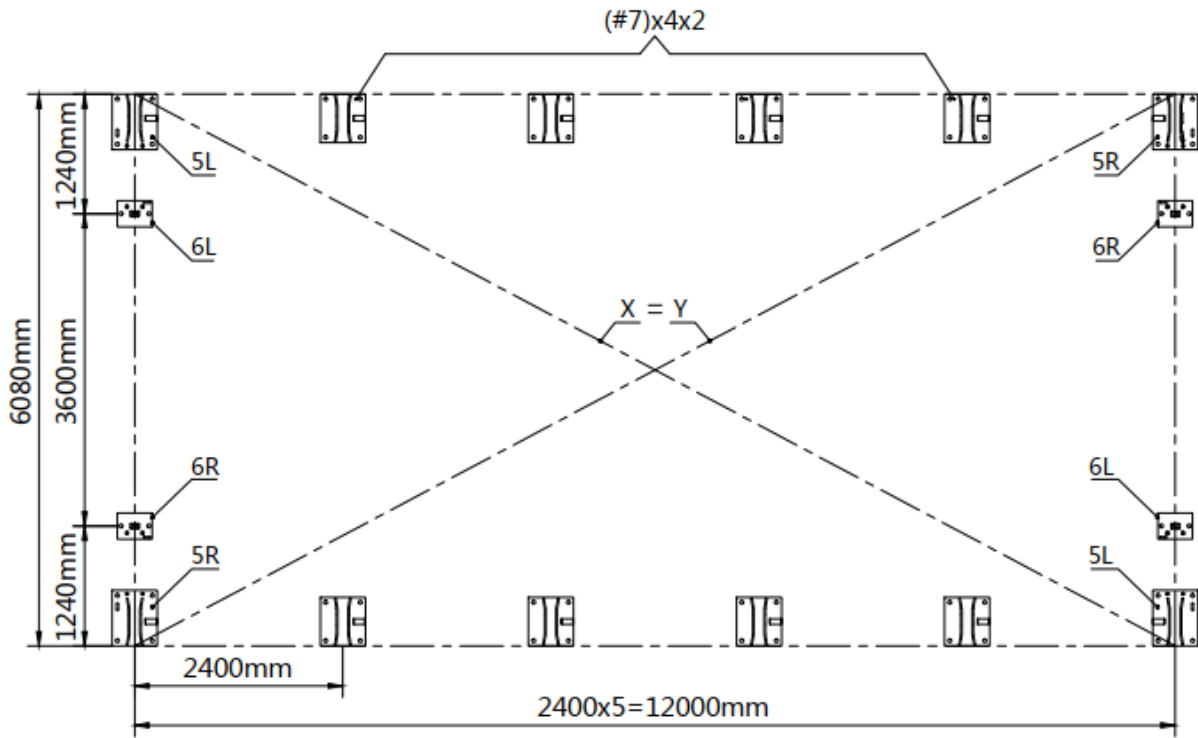

- Installation diagram of expansion bolt.

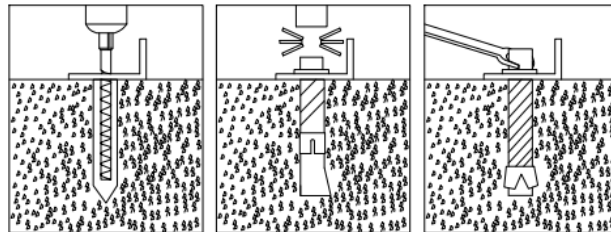



NO.	PART	QTY
5L		2
5R		2
6L		2

NO.	PART	QTY
6R		2
7		8
7B		56

STEP 2 : ASSEMBLE ALL TRUSSES.

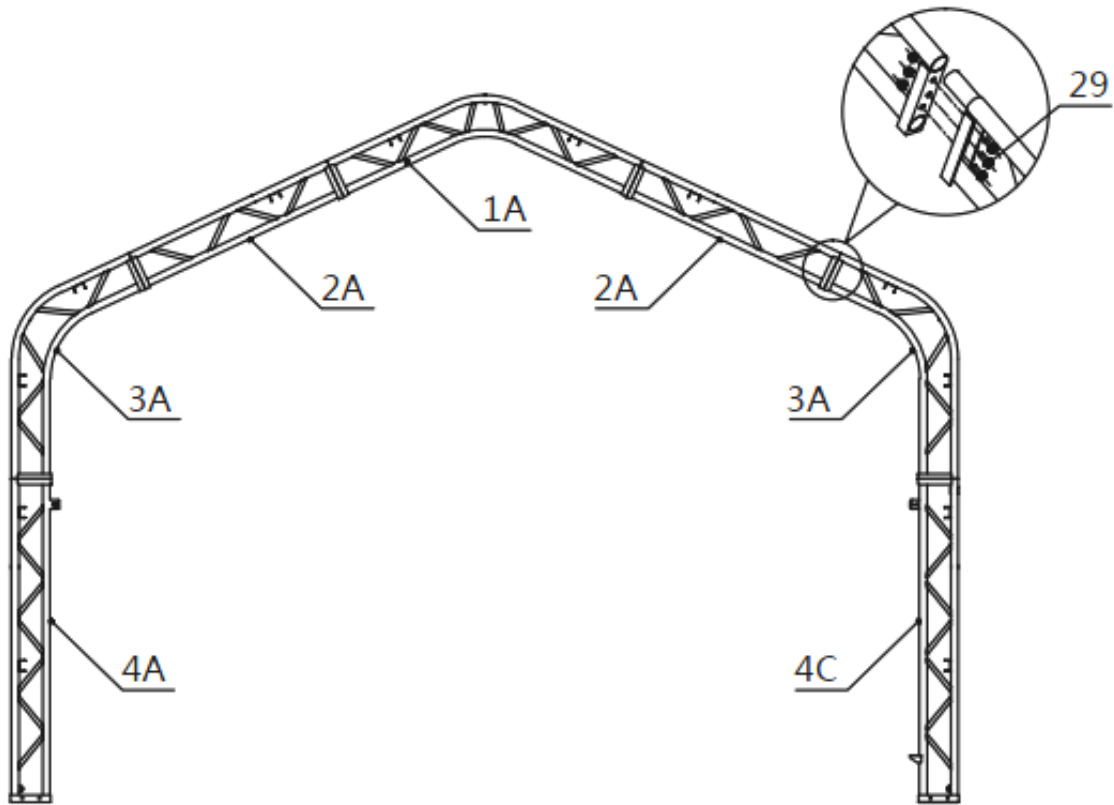
- Front truss.

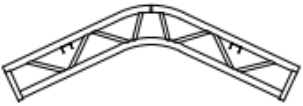
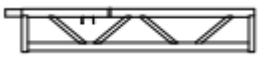



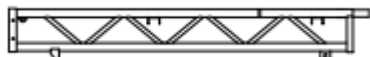
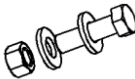

NO.	PART	QTY
1A		1
2A		2
3A		2

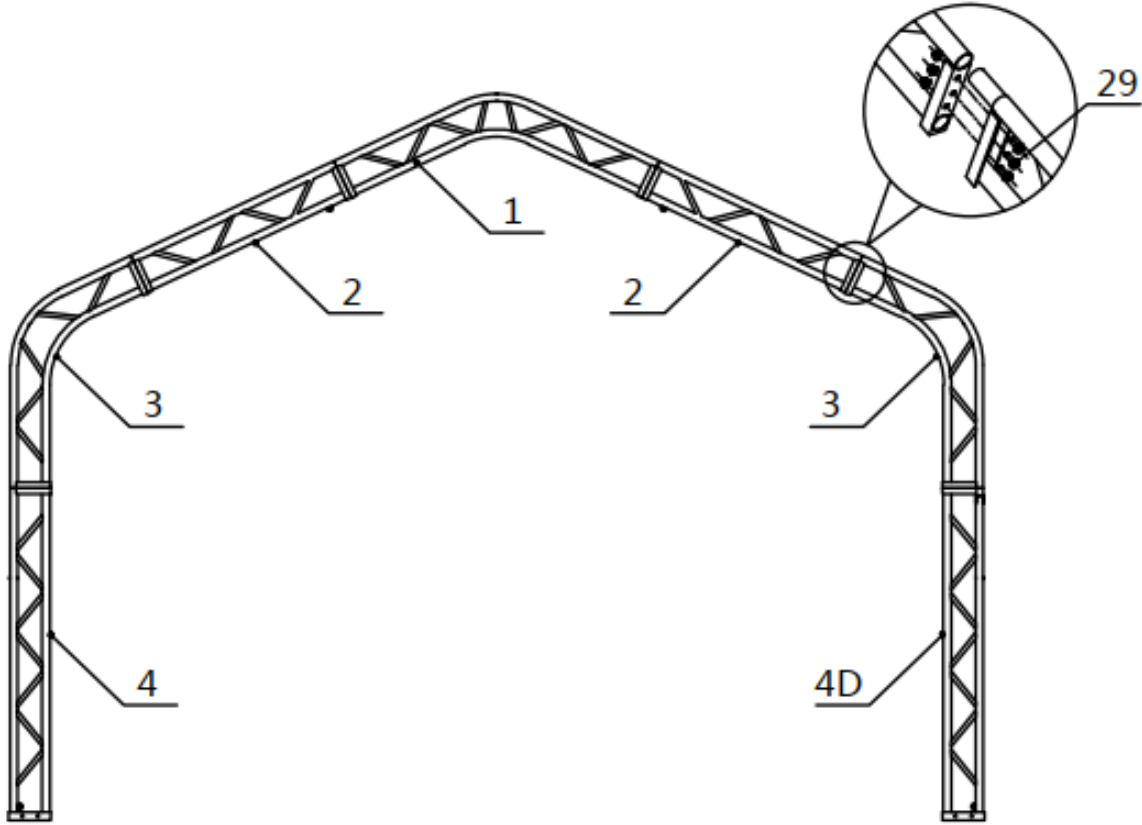
NO.	PART	QTY
4A		1
4C		1
29		18

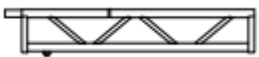
- Second truss.



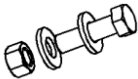

NO.	PART	QTY
1		1
2		2
3		2

NO.	PART	QTY
4		1
4D		1
29		18

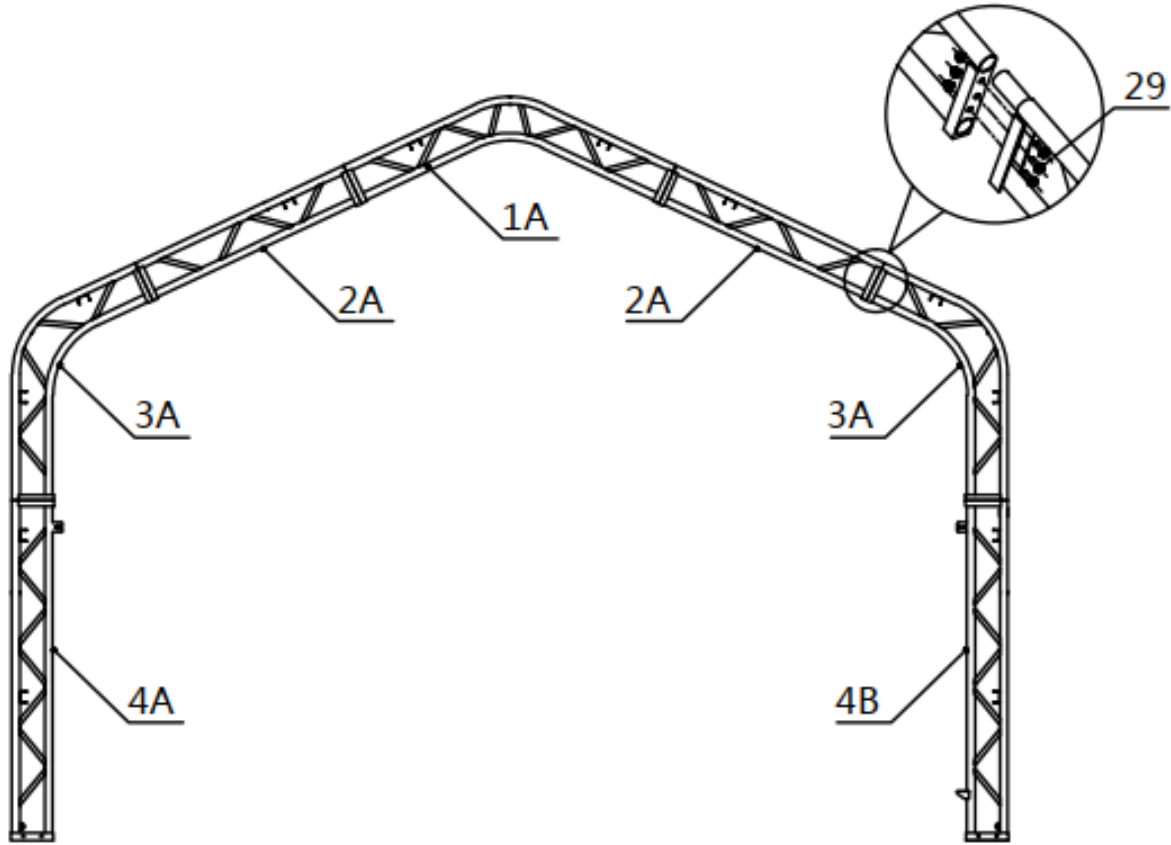
- Rear truss.

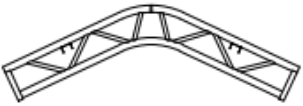
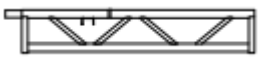

NO.	PART	QTY
1A		1
2A		2
3A		2

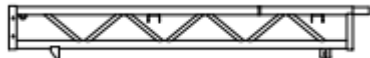
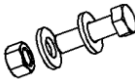
NO.	PART	QTY
4A		1
4B		1
29		18

- The rest of the trusses. (3 trusses)

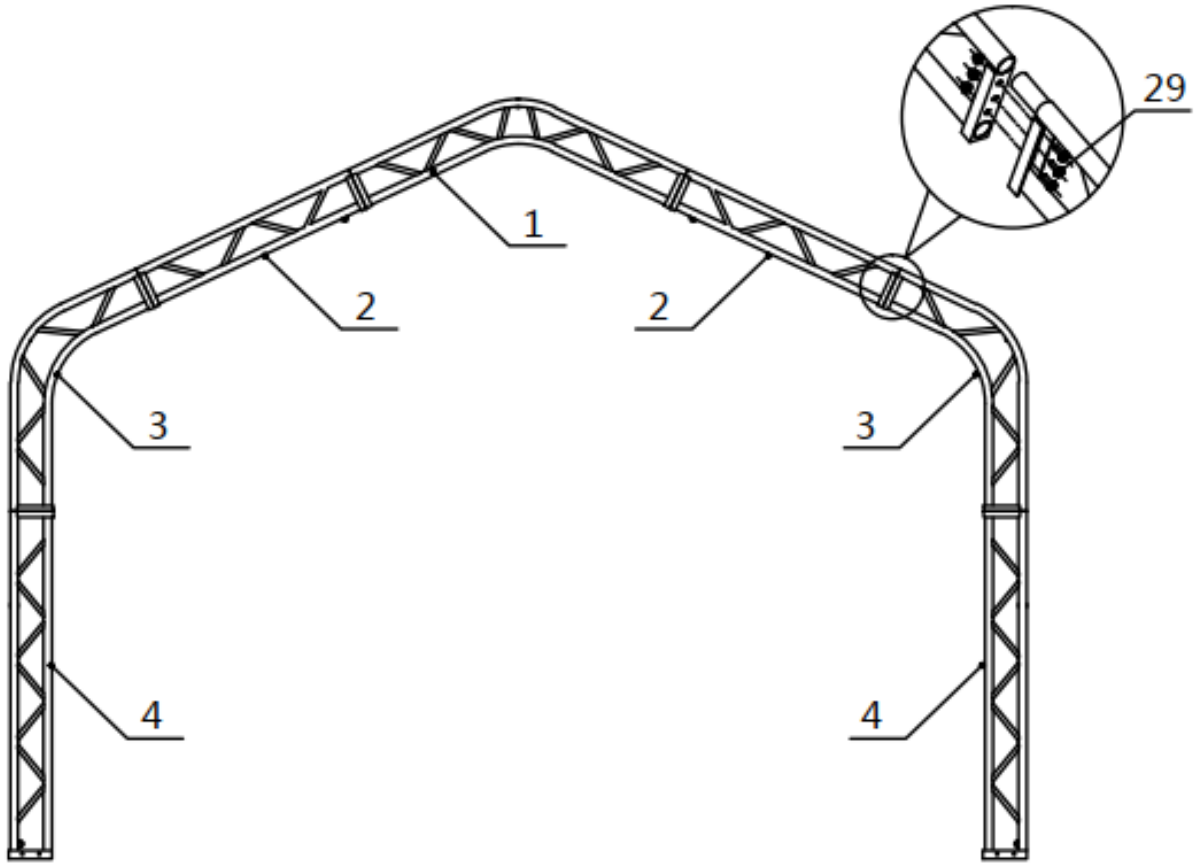

NO.	PART	QTY
1		1x3
2		2x3
3		2x3

NO.	PART	QTY
4		2x3
29		18x3

- Lay down all (6) trusses on the ground when the assembly is all completed and before moving to next step, and then wrap (#38) around the sharp points of the joint to avoid friction between the fabric and the interface, resulting in fabric damage.

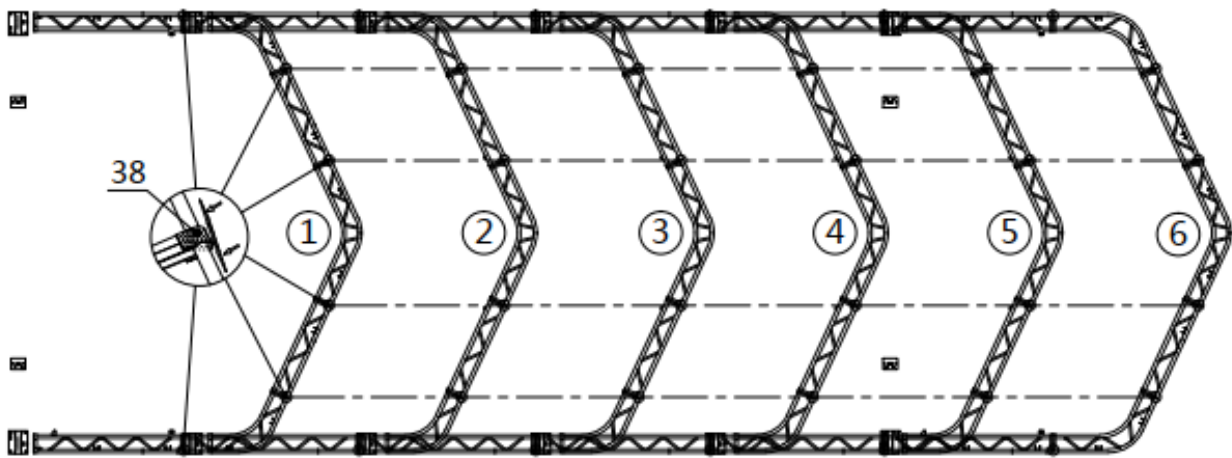

NO.	PART	QTY
38		2

STEP 3 : PUT UP THE FRONT TRUSS. (IT IS SUGGESTED TO USE CRANE FOR HOISTING)

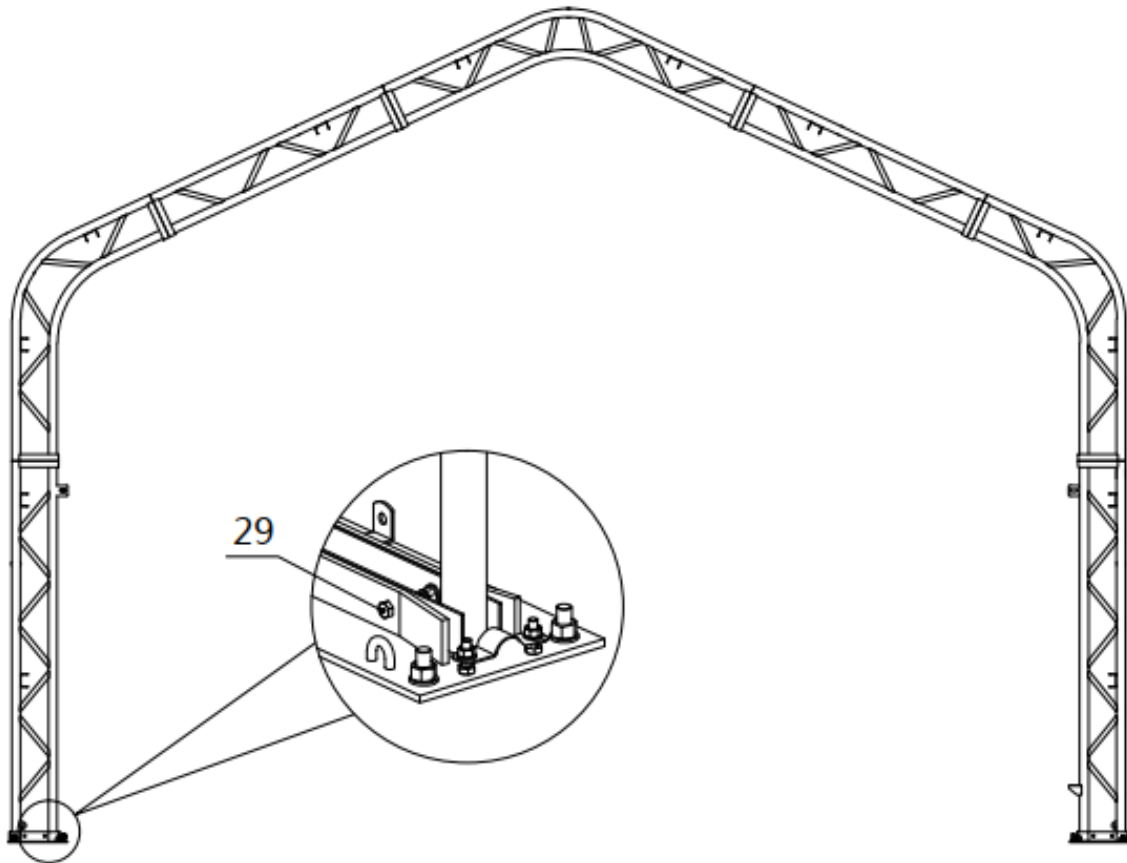

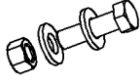
NO.	PART	QTY
29		8

STEP 4 : PUT UP THE REST TRUSSES.

- Refer to step 3 to put up the rest trusses, connect all purlins (#5) with bolt (#28) and secure all bolts firmly on each span before going to next truss .

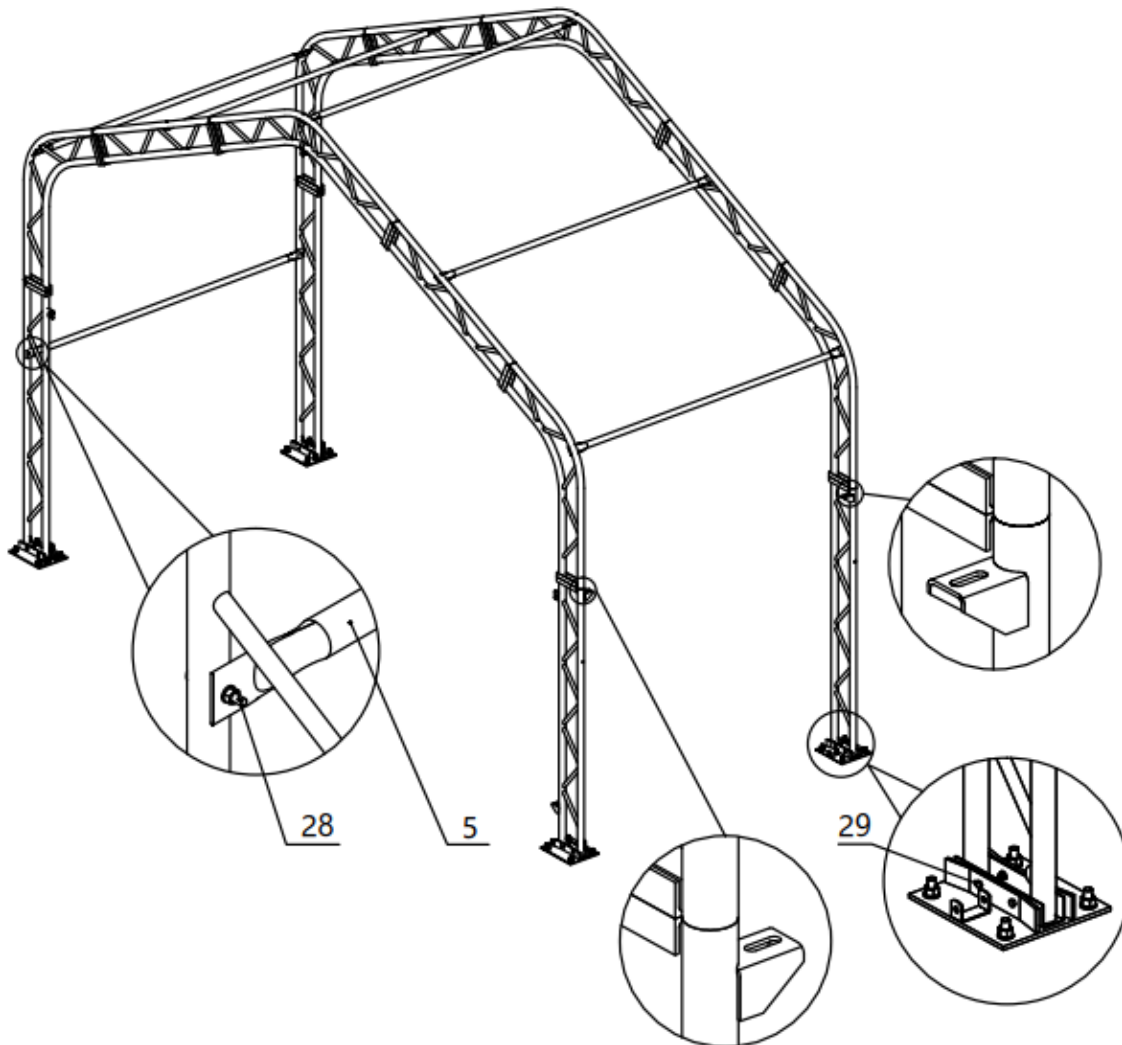

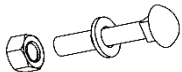

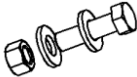
NO.	PART	QTY
5		6
28		12

NO.	PART	QTY
29		8

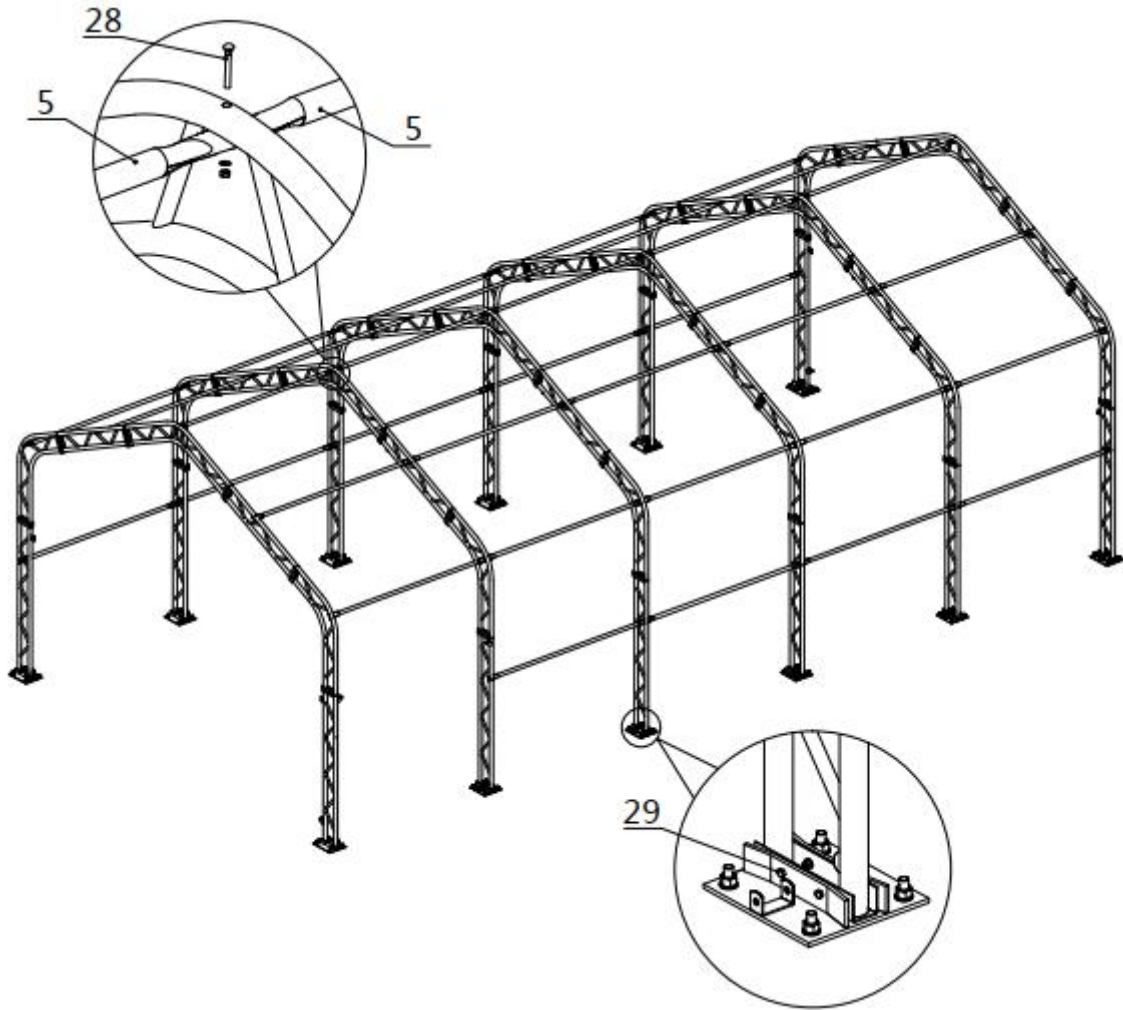
- Repeat above step to put up all other trusses (from 3rd to 6th truss), and connect all purlins.

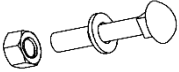



NO.	PART	QTY
5		28
28		29

NO.	PART	QTY
29		32

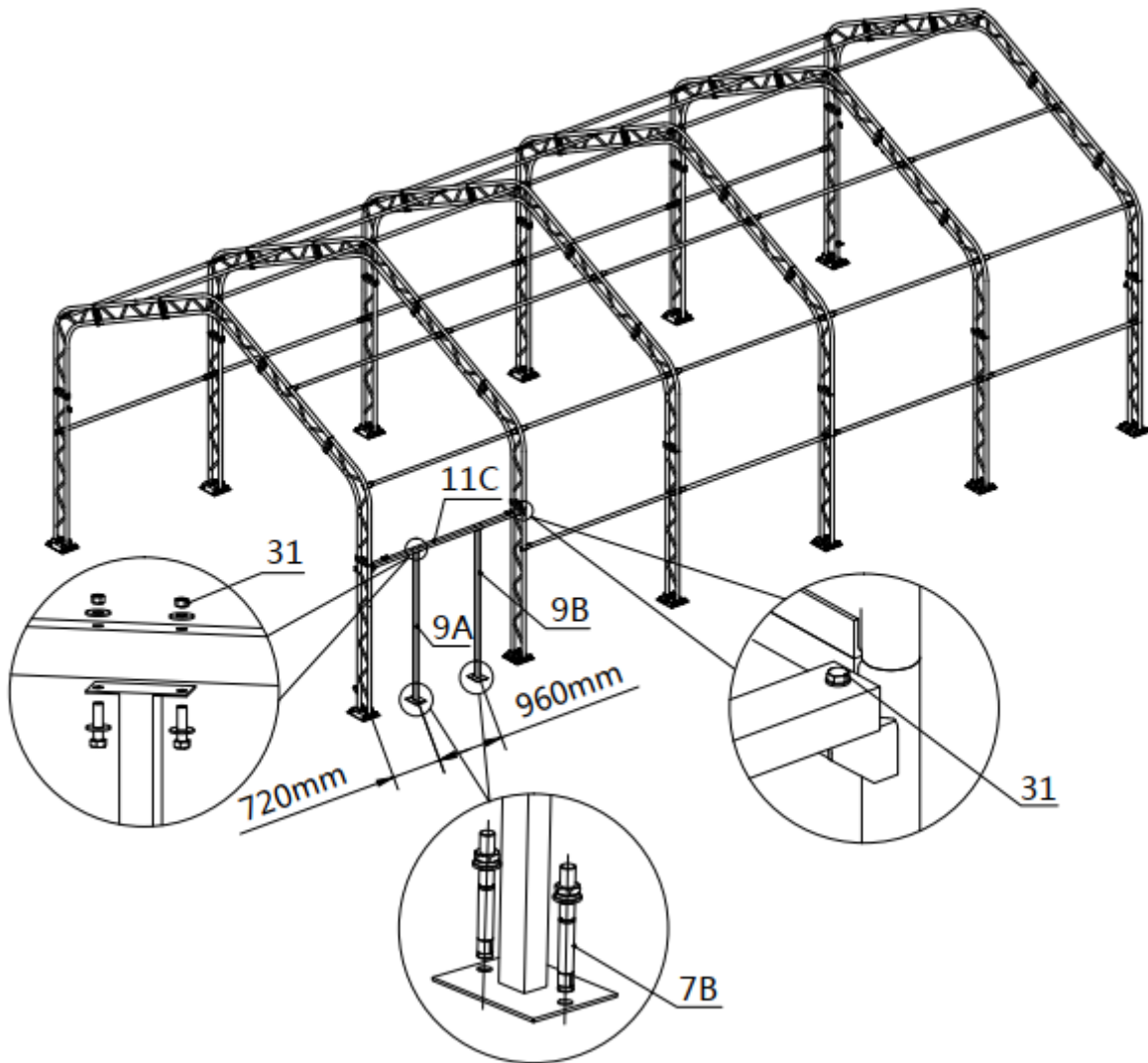
- Install the side door frame.

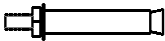
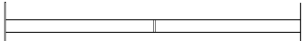
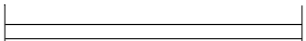

NO.	PART	QTY
7B		4
9A		1
9B		1

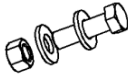
NO.	PART	QTY
11C		1
31		6

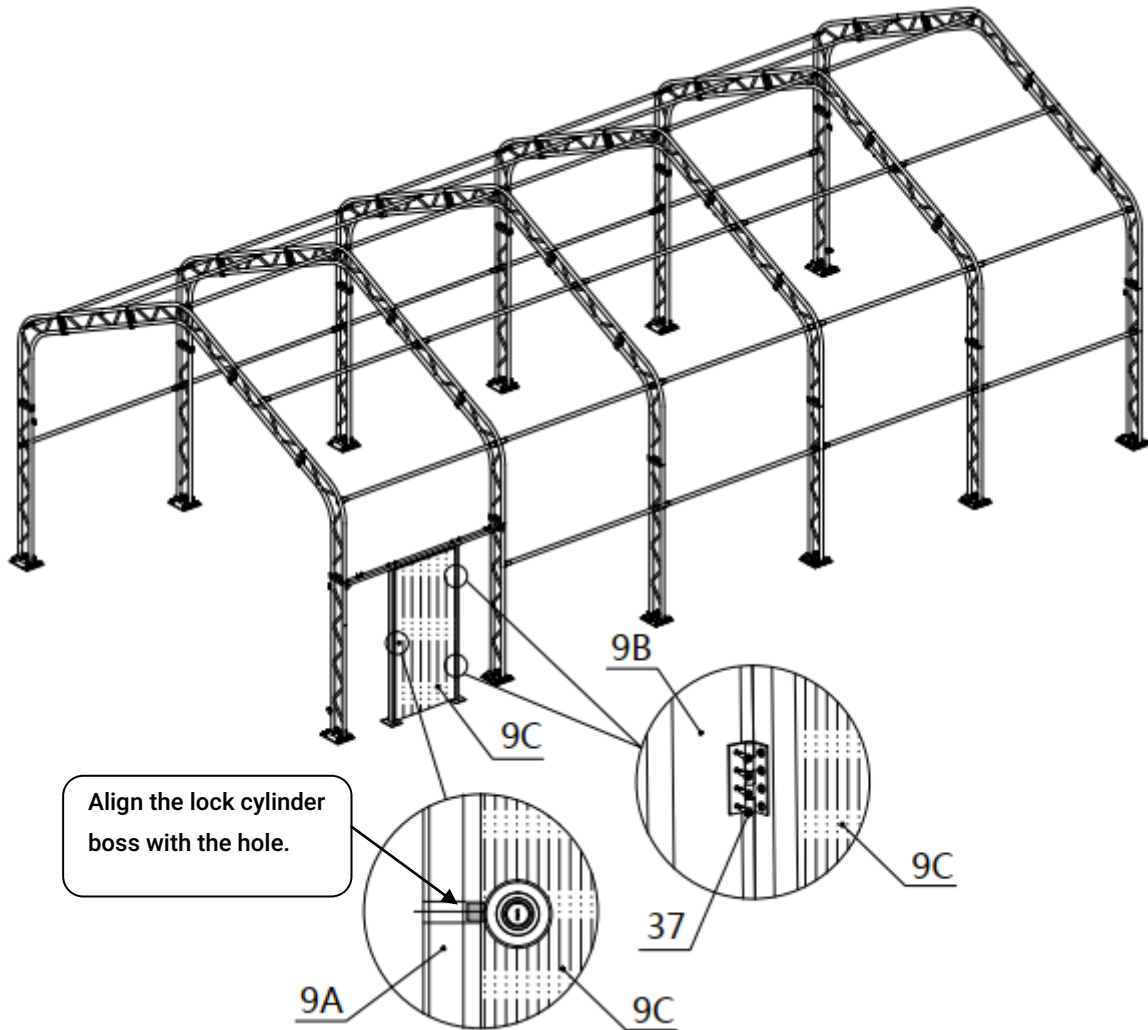

- Install the side door.

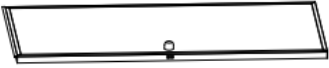
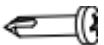

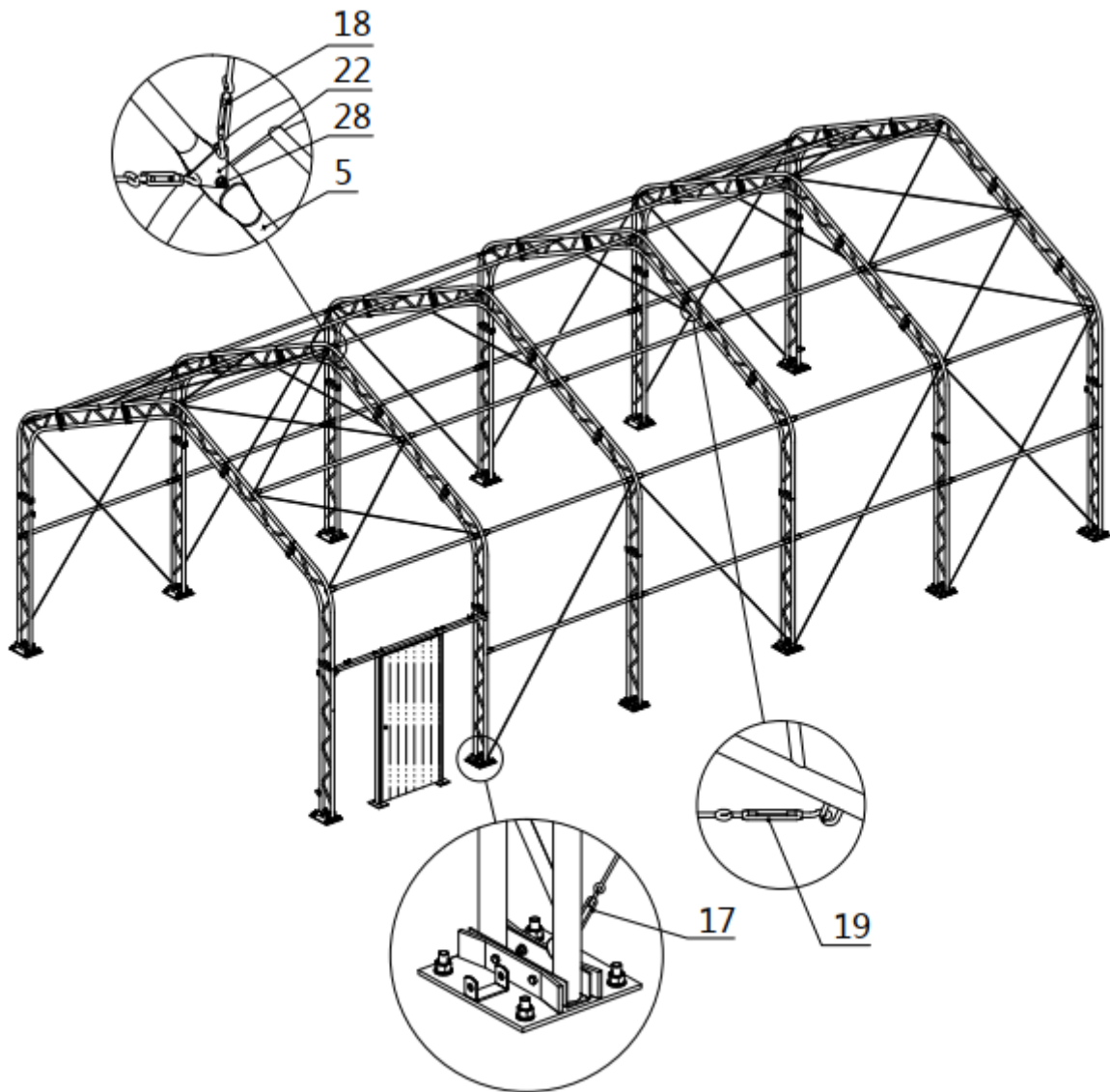

NO.	PART	QTY
9C		1
37		8

- Tension cable installation . All cables are diagonally installed on each side of the interval.



NO.	PART	QTY
17		12
18		16

NO.	PART	QTY
19		4
22		24

STEP 5 : FRONT AND REAR TRUSSES TO COMPLETE. (2 TRUSSES)

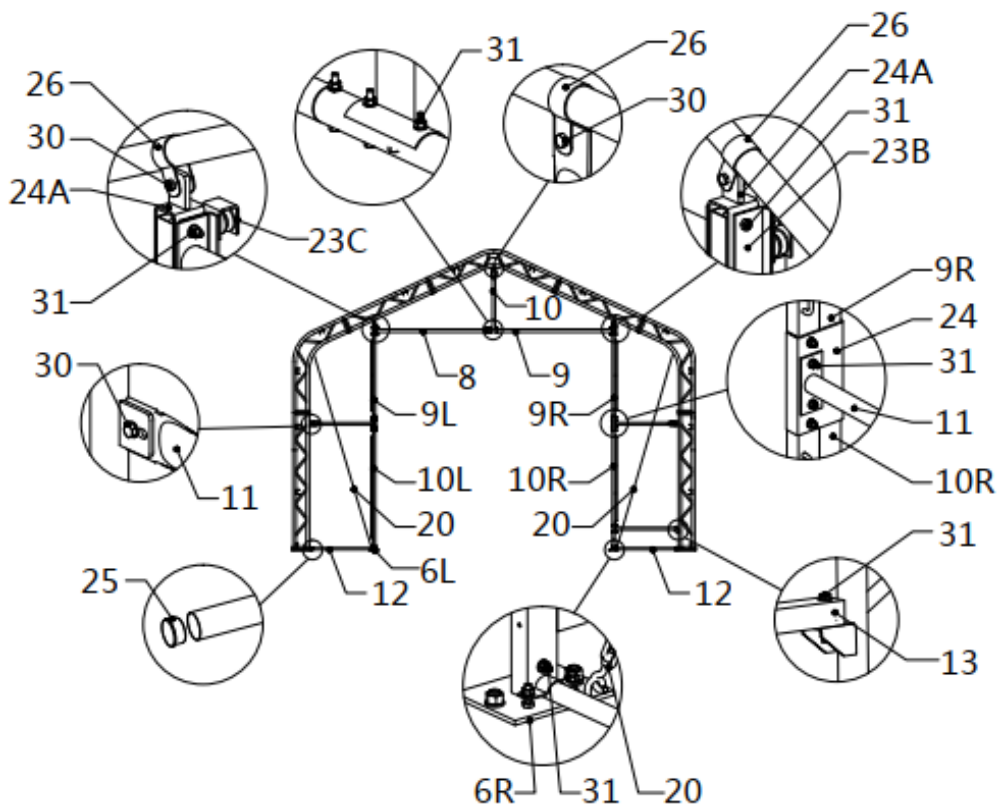



NO.	PART	QTY
8		1x2
9		1x2
9L		1x2
9R		1x2
10L		1x2
10R		1x2
10		1x2
11		2x2
12		2x2
13		1x2

NO.	PART	QTY
20		2x2
23B		1x2
23C		1x2
24		2x2
24A		2x2
25		4x2
26		3x2
30		5x2
31		20x2

STEP 6 : INSTALL FRONT AND REAR COVER PANELS.

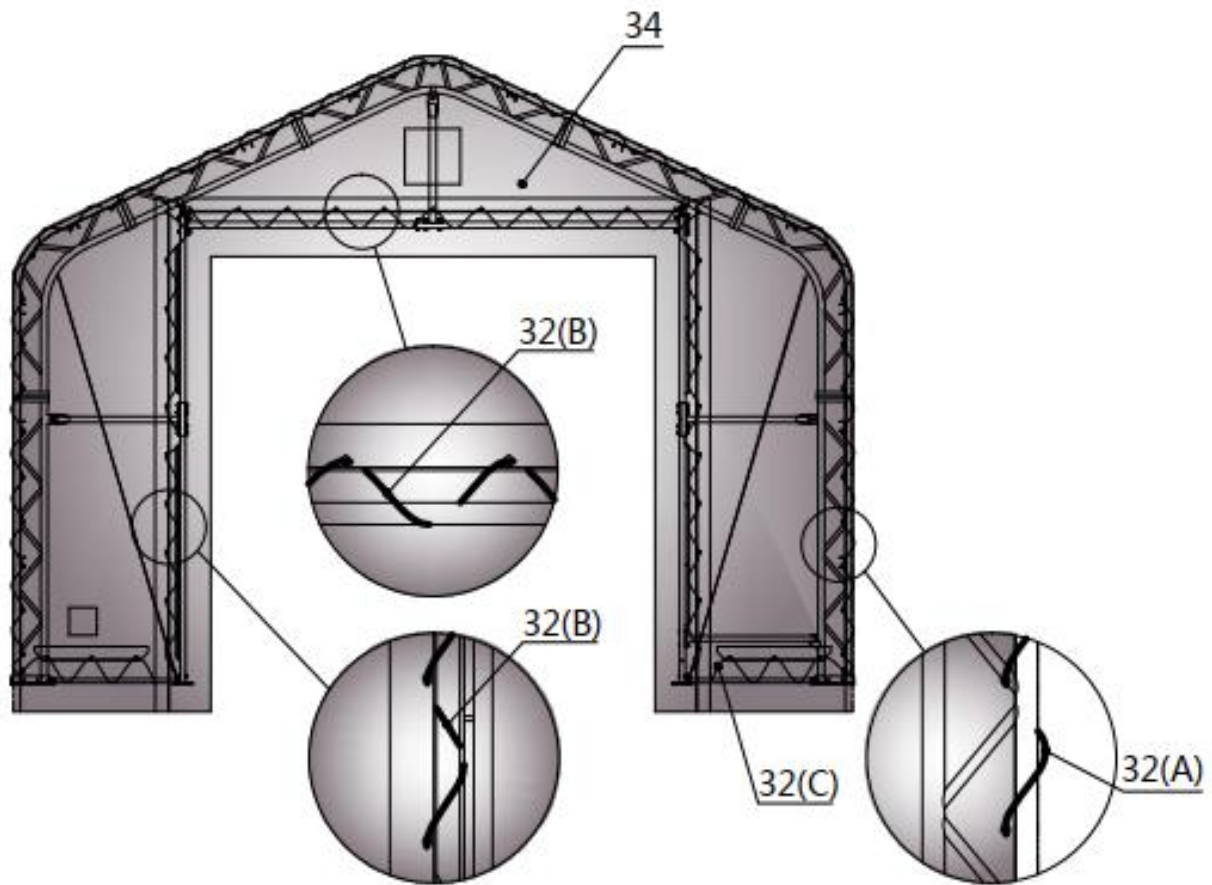
- Lift up (#34) cover panels, starting from the center point of the frame (highest ridge point) use ropes (#32) through the grommets to tie the panel to the truss firmly. All grommets need to be tied to the frame as shown.

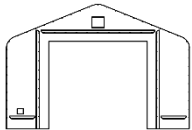

NO.	PART	QTY
32		84m
34		1x2

ROPE SHEAR SIZE		
32		QTY
A	20m	1x2
B	6m	3x2
C	2m	2x2

- Install the front and rear door pressing plate.

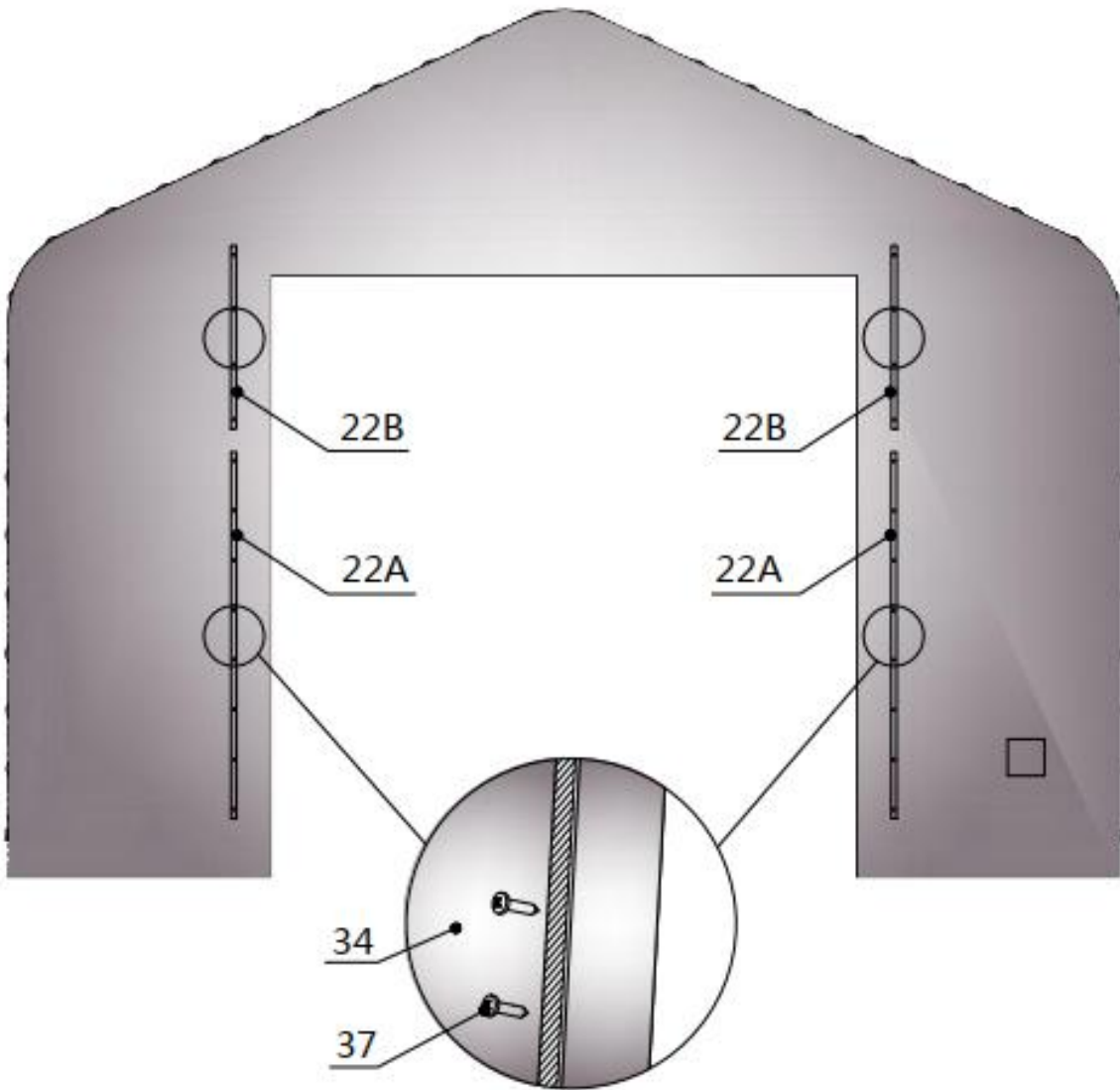



NO.	PART	QTY
22A		2x2
22B		2x2
37		24x2

STEP 7 : INSTALL MECHANICAL ROLL UP DOORS.

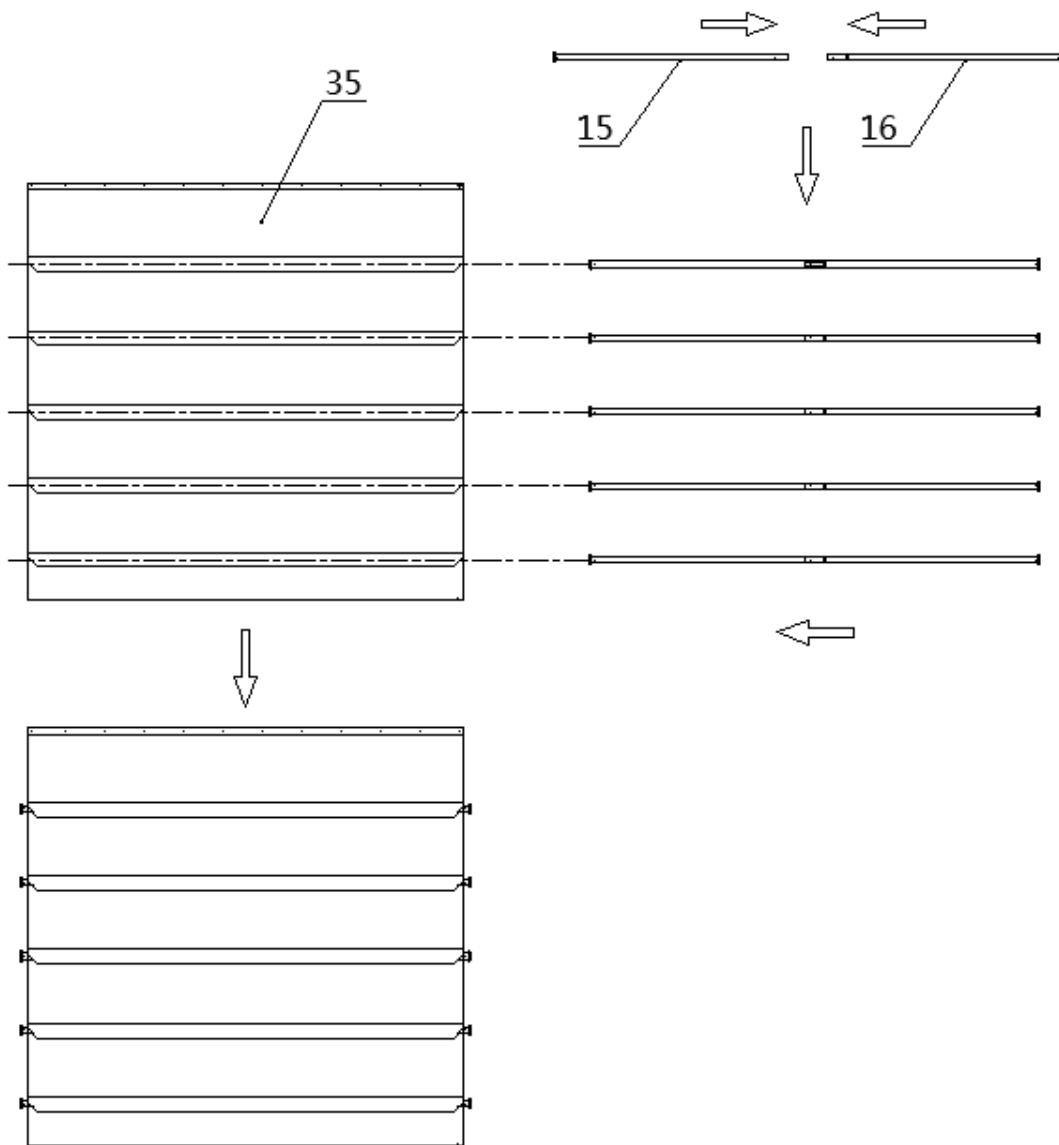
- Door curtain installation.





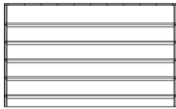

NO.	PART	QTY
15		5x2
16		5x2

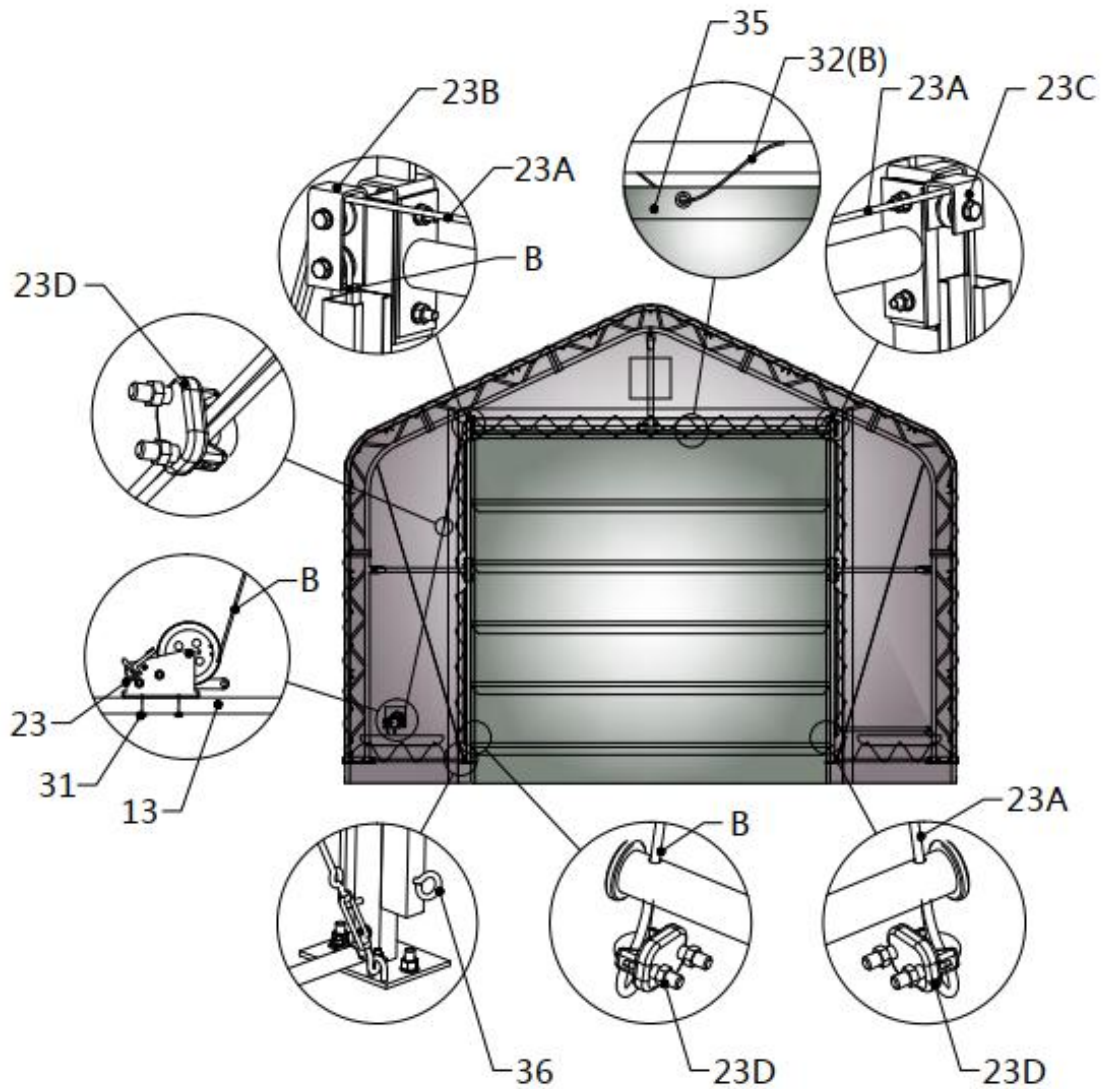
NO.	PART	QTY
35		1x2

- Front and rear door installation, please look at the door from inside.
- The hand winch (#23) comes with a shorter cable, we call it cable (#B).

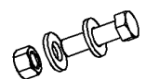

NO.	PART	QTY
23		1x2
23A		1x2
23D		3x2

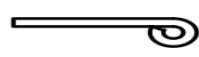
NO.	PART	QTY
31		2x2
32(B)		6m
36		1x2

STEP 8 : INSTALL ROOF COVER.

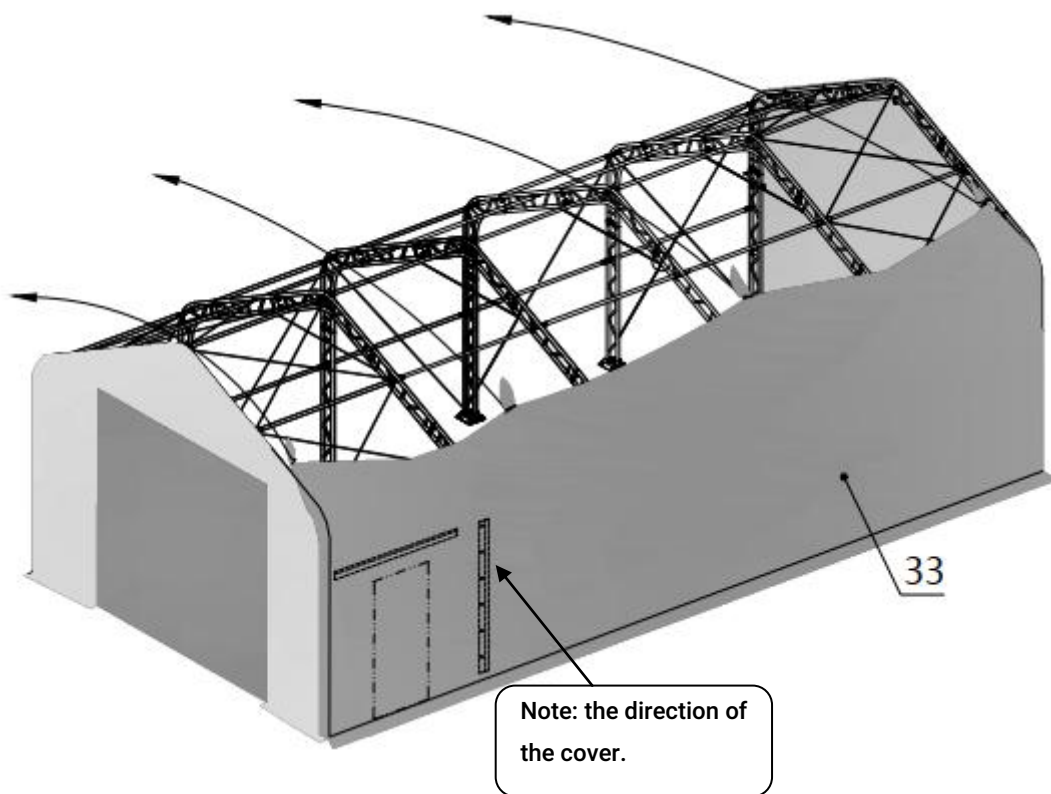

- **NOTE:** The cover must be installed on a windless day. **DO NOT** attempt to install the cover during windy conditions.
- When you are ready to install the roof cover, unpack the cover and position it parallel to the building frame on one side.
- The cover must be pulled over the top of the truss frame without being snagged or stressed on any frame members.
- Use multiple ropes over the top of the frame as shown. Having a couple of people inside of the structure with a ladder to assist to push upwards would help the cover to be pulled over smoothly without any damage.

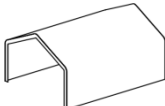

NO.	PART	QTY
33		1

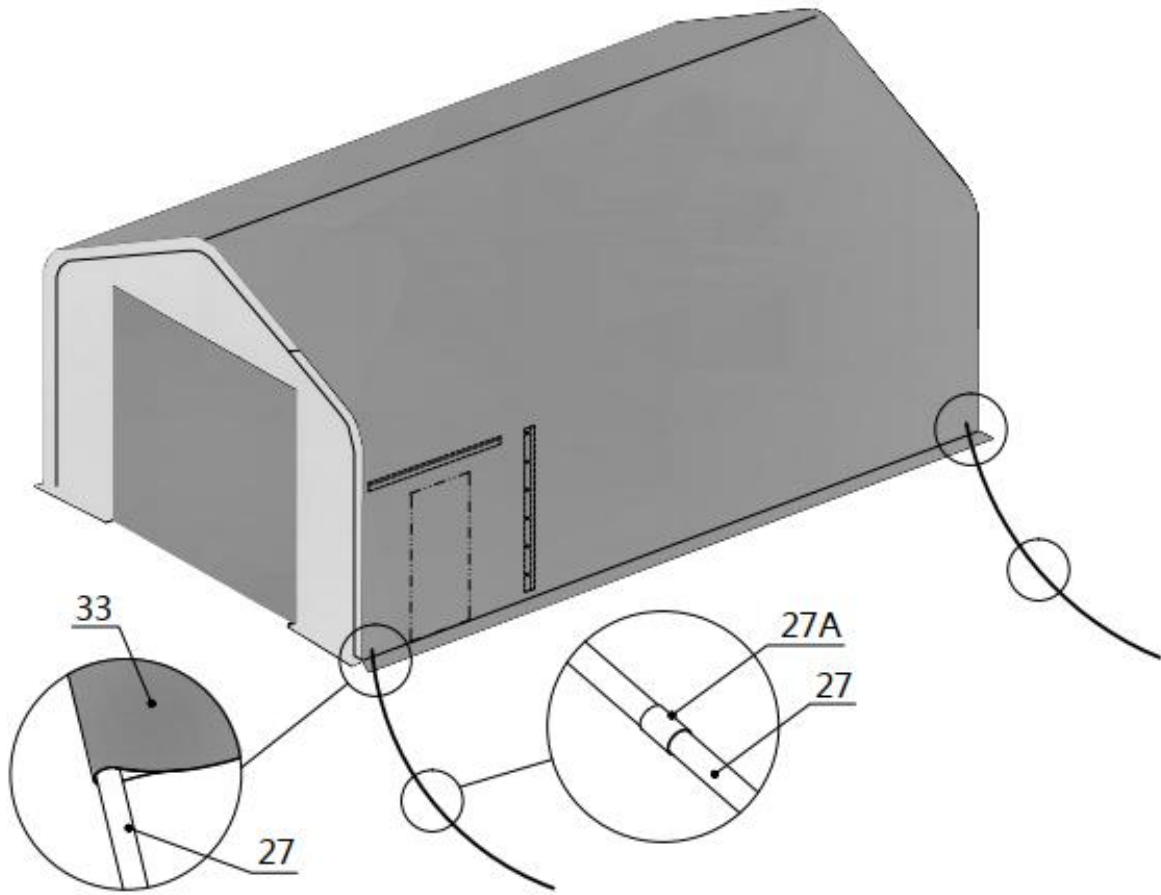
- After the cover is installed on the roof, insert the plastic pipe (#27) slowly into the grooves on two ends of the cover (not two sides).



NO.	PART	QTY
27		7
27A		6

- Then insert tension tubes (#14,#14A.#14B) in the groove on both sides of the cover bottom.

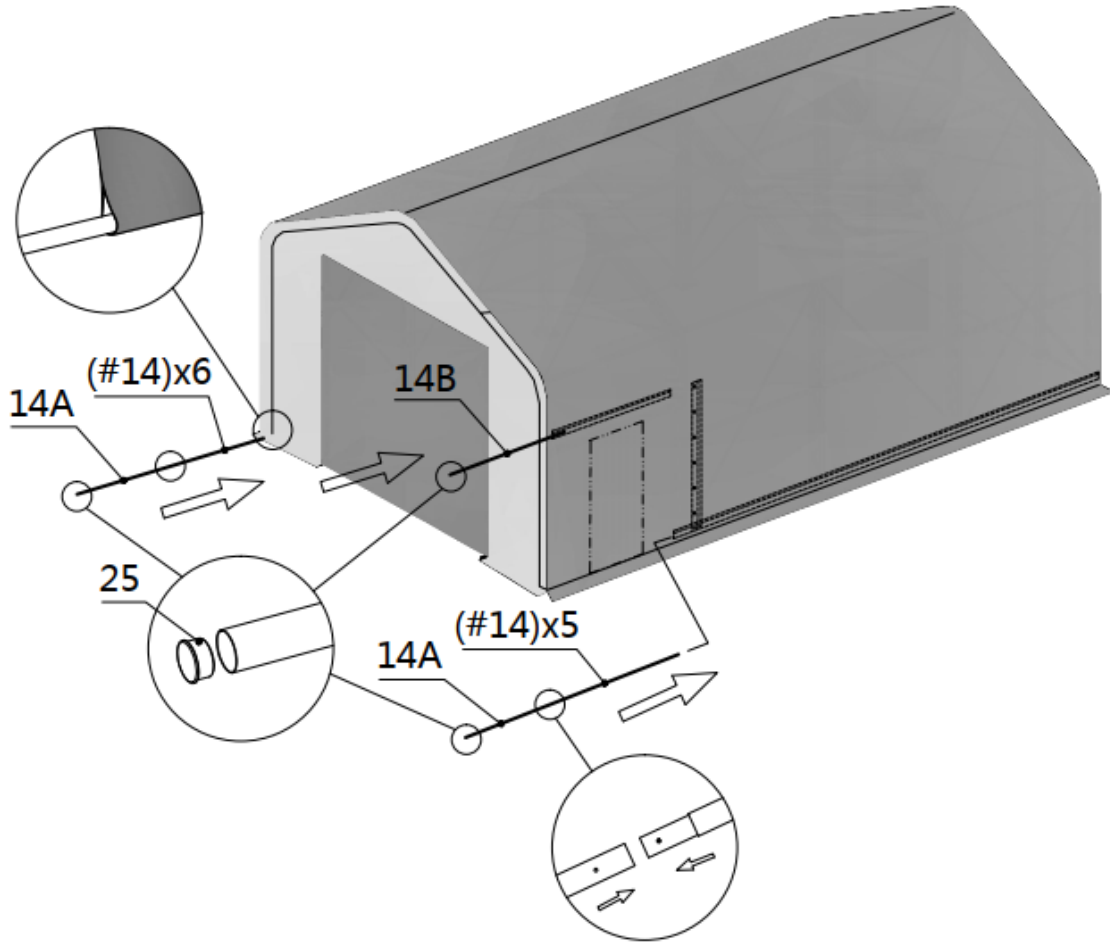



NO.	PART	QTY
14		11
14A		2

NO.	PART	QTY
14B		1
25		6

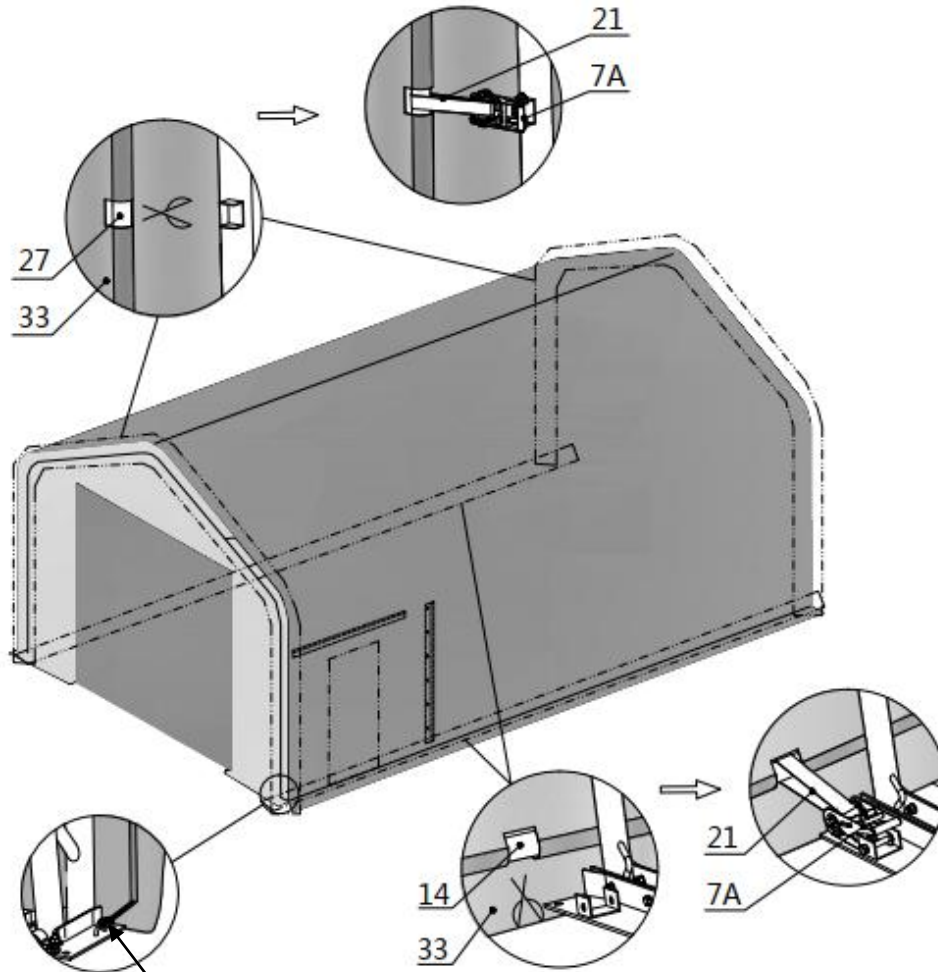
- Stretch and adjust the cover from left and right, back and forth, to make sure it is square and centered. Cut the grooves from inner side facing to the ratchet hardware (#7A), and add tie down straps (#21) to pull the tension tube and tie the strap to the base.
- Evenly adjust all ratchets on both sides to take wrinkles out and make the cover flat and smooth.





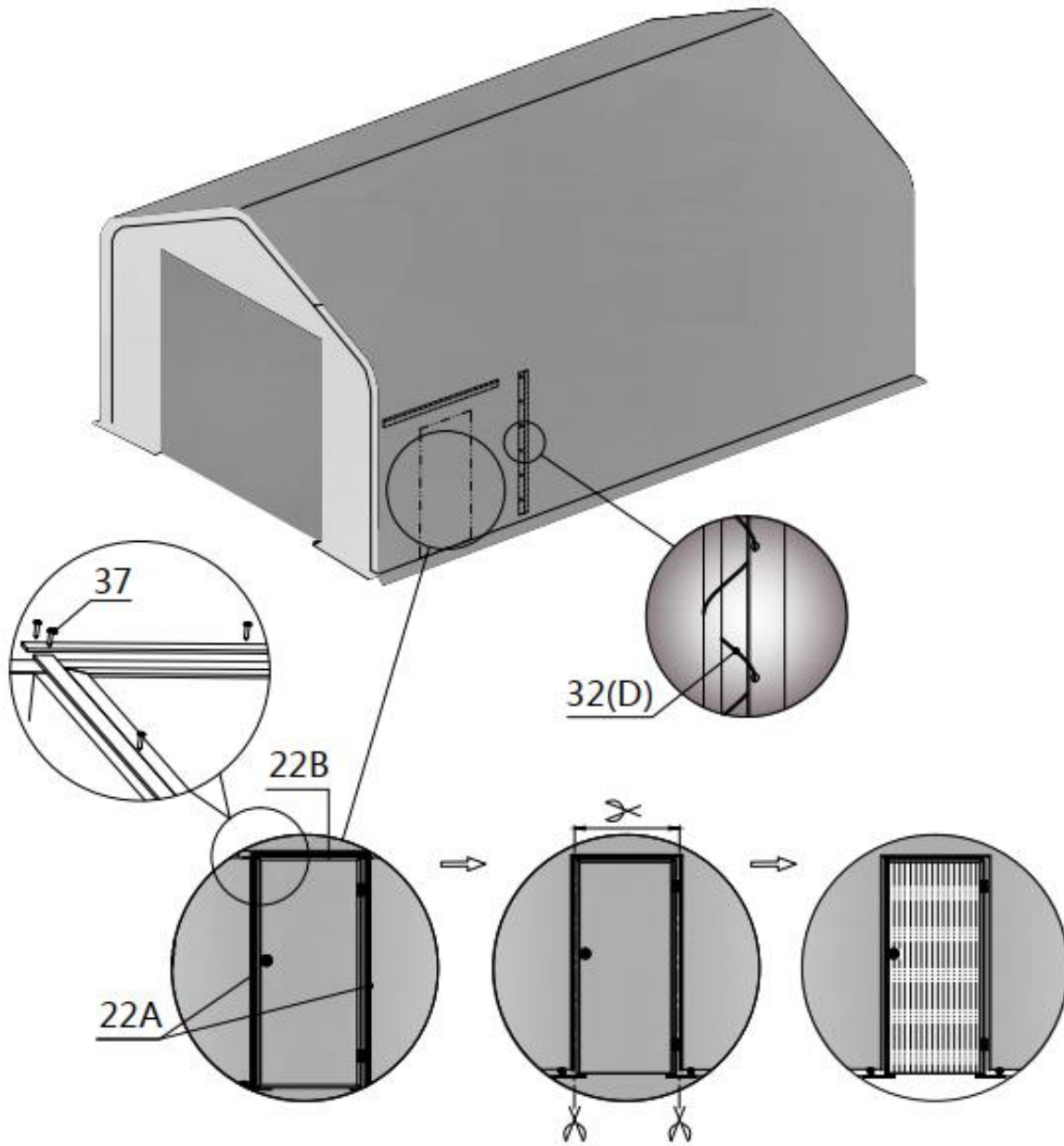

Tighten the cords at both ends of the cover cloth and tie them to the base plate

NO.	PART	QTY
7A		37
21		37

- Complete side door installation.



NO.	PART	QTY
22A		2
22B		1

NO.	PART	QTY
32(D)		4m
37		20

AFTER THE INSTALLATION

Walk around and inspect the building periodically to make sure all components are still firmly secured and the whole building is well supported. Check all bolts and nuts as well as all connection points to make sure they are all in good position. Check the base plates, adjust the ropes and tie downs if required and clean the cover regularly.

Snow accumulating on the fabric cover must be removed as soon as possible. If snow becomes solid ice on the cover, it will increase the weight on the roof and collapses the building or reduce the life span eventually.

Keep the building on a dry ground most of the time. Do not keep the fabric dirt skirt under water all the time, otherwise the fabric will deteriorate.

We strongly recommend you remove any snow from the roof immediately. Do not leave any snow load on the roof overnight. Keep 3 feet of clearance on all sides at all times. Do not allow snow to accumulate and pile up on the sides of the building. Otherwise the push from the sides toward inside will make the building collapsed at some point.