

# 20Ft x 30Ft All-Steel Carport

Model: TMG-CP2030F-1.0

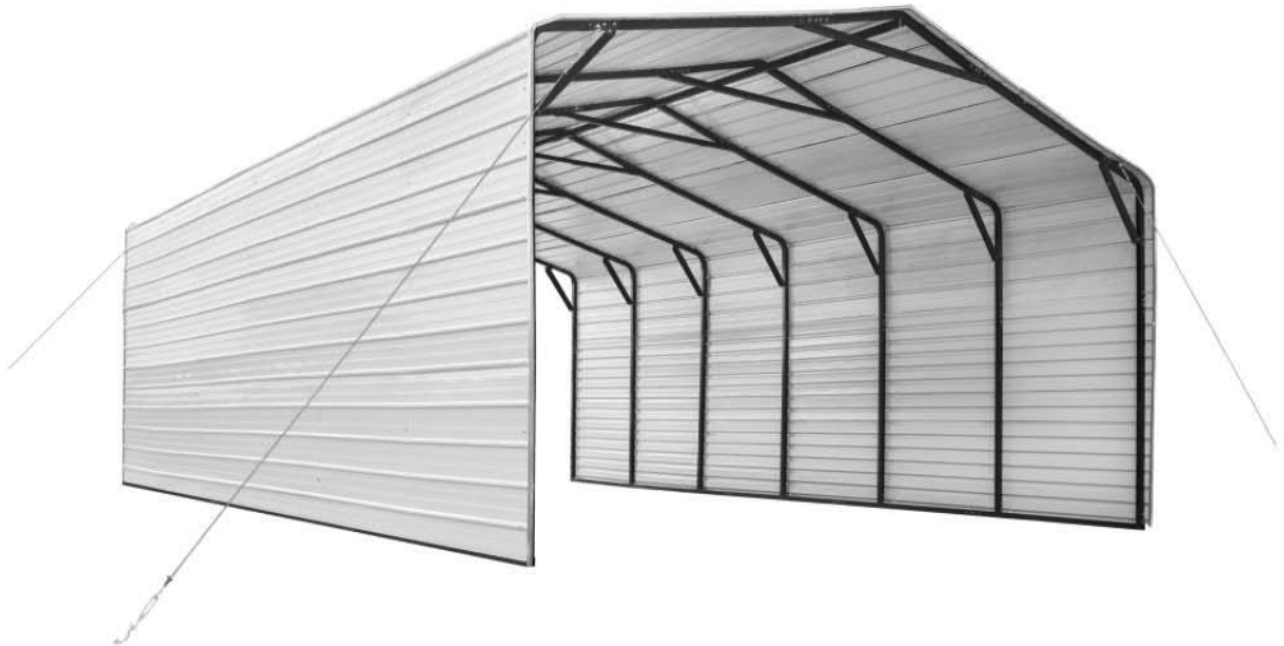

- Please read the product manual completely before assembly
- Check against the parts list to make sure all parts are received
- Wear proper safety goggles or other protective gears while in assembly

Missing parts or questions on assembly?

Please call: 1-877-761-2819 or email: [cs@tmgindustrial.com](mailto:cs@tmgindustrial.com)

Do not return the product to dealer, they are not equipped to handle your requests

## **Main Specifications :**

- Overall assembled size : W6 x L9 x H3.78 (m) / 20 x 30 x 12 (ft)
- Width : 6 m / 20ft
- Length : 9 m / 30 ft
- Ridge peak height : 3.78 m / 12 ft
- Shoulder wall clearance height : 3.0 m / 10 ft

## **Prior to assembly**

Please read the instructions carefully before installation. It is very important to follow your local safety regulations and industry standards during installation. Regulations may include but are not limited to:

- Safety helmets, protective eyewear, and clothing
- Safety harnesses for all elevated workers
- Proper ladder, cage, and safety operation

Check all components and parts before installation. All parts are marked with a part number, please refer to the parts list to make sure you have all parts.









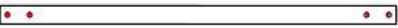

Choose a day with low or no wind to install, assembly is hard in heavy wind. Do not make any alterations to the structure. Do not hang any weights on the frame during installation, including parts. We are not responsible for any damages or injuries caused by inappropriate installation, unauthorized modifications or extreme weather.

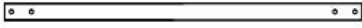





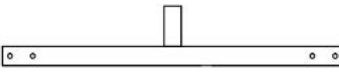

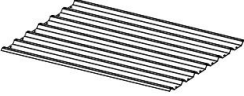
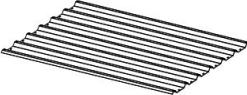





This building is not intended for human occupancy.

It is recommended to tape or add foam/rubber on the frame where joints connect and where it touches the cover. This will help extend the life span of the cover.

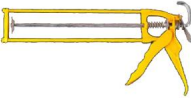
Read the following item list carefully and count the number of items to ensure that all parts are included prior to setup.

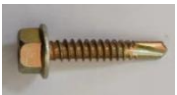
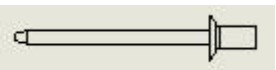
### TMG-CP2030F-1.0 Part List

Parts code	Graphical	Description	Qty	BOX
1		Peak arch tube	7	1/1
2		Middle rafter tube	14	1/1
3		Shoulder tube	12	1/1
3A		Shoulder tube (middle)	2	1/1
4		Sidewall tube	14	1/1
4A		Short casing	55	1/1
5C		Top cross bar A	5	1/1
5D		Top cross bar B	1	1/1
6		Ceiling cross bar	7	1/1
6A		Foot tube (front and rear)	4	1/1
6B		Foot tube (front and rear)	4	1/1
6C		Foot tube (middle)	2	1/1
6D		Reinforcing tube	14	1/1
6E		Reinforced tube mounting plate	84	1/1
7		Metal sheet (front and rear truss)	30	1/1
8		Metal sheet (middle truss)	60	1/1

9A		Edge protector	14	1/1
10		Edge buckle	12	1/1
11		Water plug	6	1/1
12		Steel cable mounting plate	4	1/1
13		Anchor hook (M14x120mm)	6	1/1
14		Steel cable (3.9m)	6	1/1
15		Expansion bolt (φ16x150mm)	14	1/1
16		Waterproof silicon sealant	5	1/1
16A		Teroson statu	1	1/1
17		Hex bolt M10x70mm	313	1/1
18		Self tapping screw M5x30mm	480	1/1
19		Rivet φ3x6mm	100	1/1
20		Corner protector	4	1/1
21		Hex bolt M10x120mm	7	1/1
22		Sleeve	2	1/1
23		Eyebolt	2	1/1

## Installation steps

### Step 1 : Review the whole structure and choose the proper installation site

Refer to the foundation structure Figure 1, draw lines on the ground for positioning, all dimension lines are drawn from the center of the pipe to the center, and the diagonal X must be equal to Y.

Installation of foundation pipes: all foundation pipes shall be connected here with (#17) hex bolts as shown in Figure 1, and fixed on the ground with (#15) expansion bolts (refer to figure 1).

- Parts used in this step :
  - (4) Foot tube (#6A)
  - (4) Foot tube (#6B)
  - (2) Foot tube (#6C)
  - (32) Hex bolt (#17)
  - (14) Expansion bolt (#15)
  - (8) Short casing (#4A)

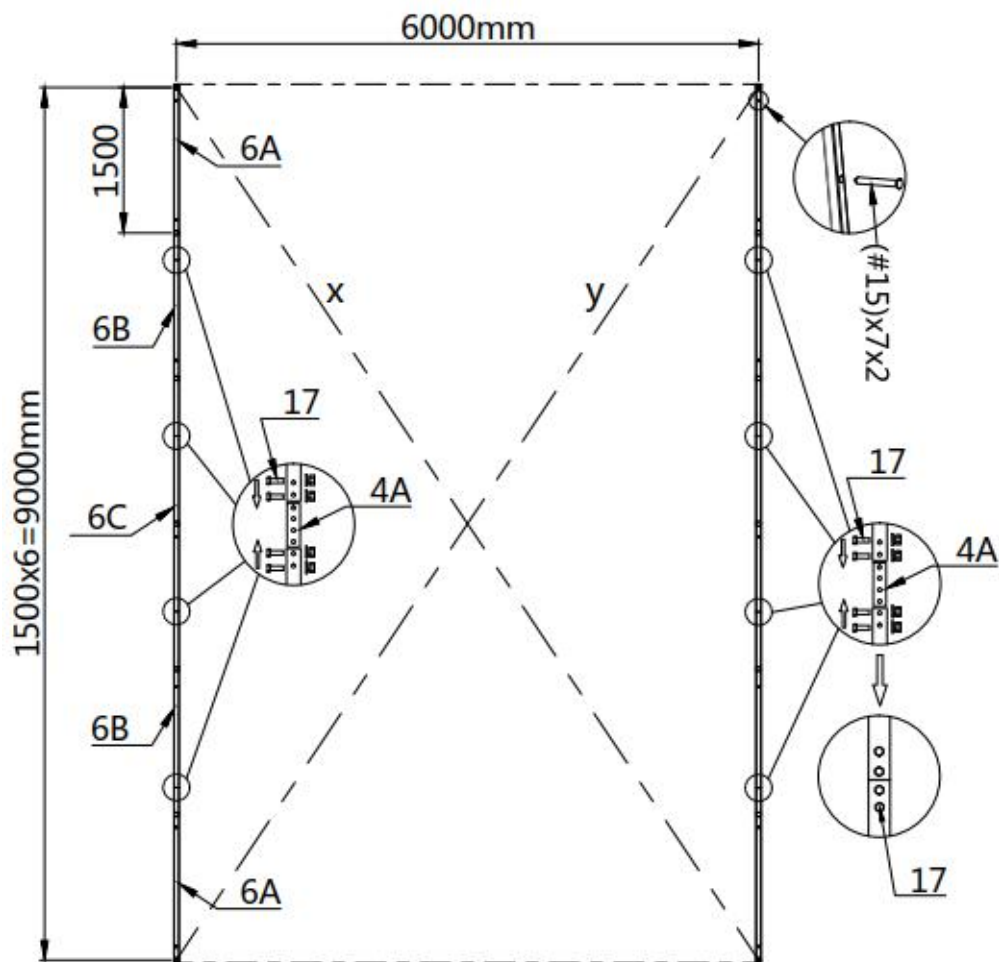

Figure 1

## Step 2 : Assemble all trusses

The building includes 7 trusses : (1) front truss, (1) rear truss, (1) middle trusses and (4) other trusses.

- Parts used to install the front and rear truss in this step (refer to figure 2).

- (1x2) Peak arch tube (#1)
- (2x2) Middle rafter tube (#2)
- (2x2) Shoulder tube (#3)
- (2x2) Sidewall tube (#4)
- (2x2) Steel cable mounting plate (#12)
- (34x2) Hex bolt (#17)
- (1x2) Ceiling cross bar (#6)
- (2x2) Reinforcing tube (#6D)
- (12x2) Reinforced tube mounting plate (#6E)
- (6x2) Short casing (#4A)

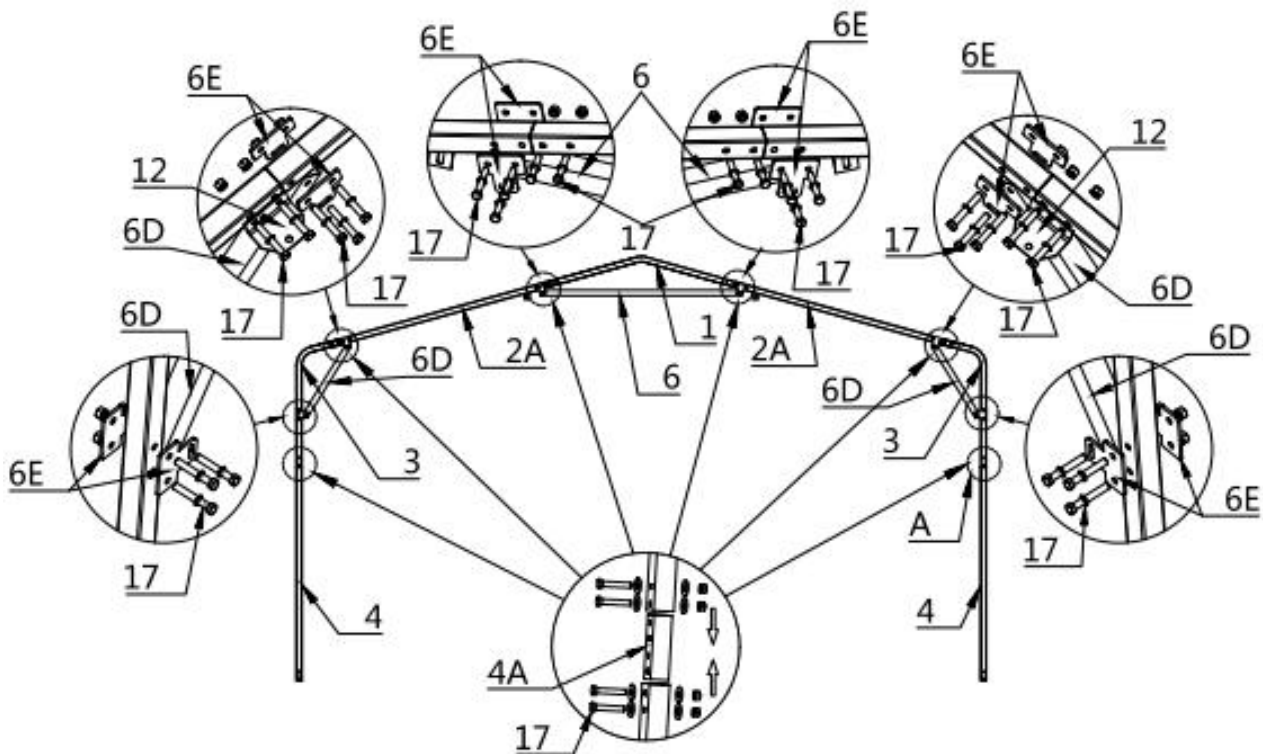

Figure 2

- Parts used to install (1) middle trusses in this step (refer to figure 3).

- (1) Peak arch tube (#1)
- (2) Middle rafter tube (#2)
- (2) Shoulder tube (#3A)
- (2) Sidewall tube (#4)

- (34) Hex bolt (#17)
- (1) Ceiling cross bar (#6)
- (2) Reinforcing tube (#6D)
- (12) Reinforced tube mounting plate (#6E)
- (6) Short casing (#4A)

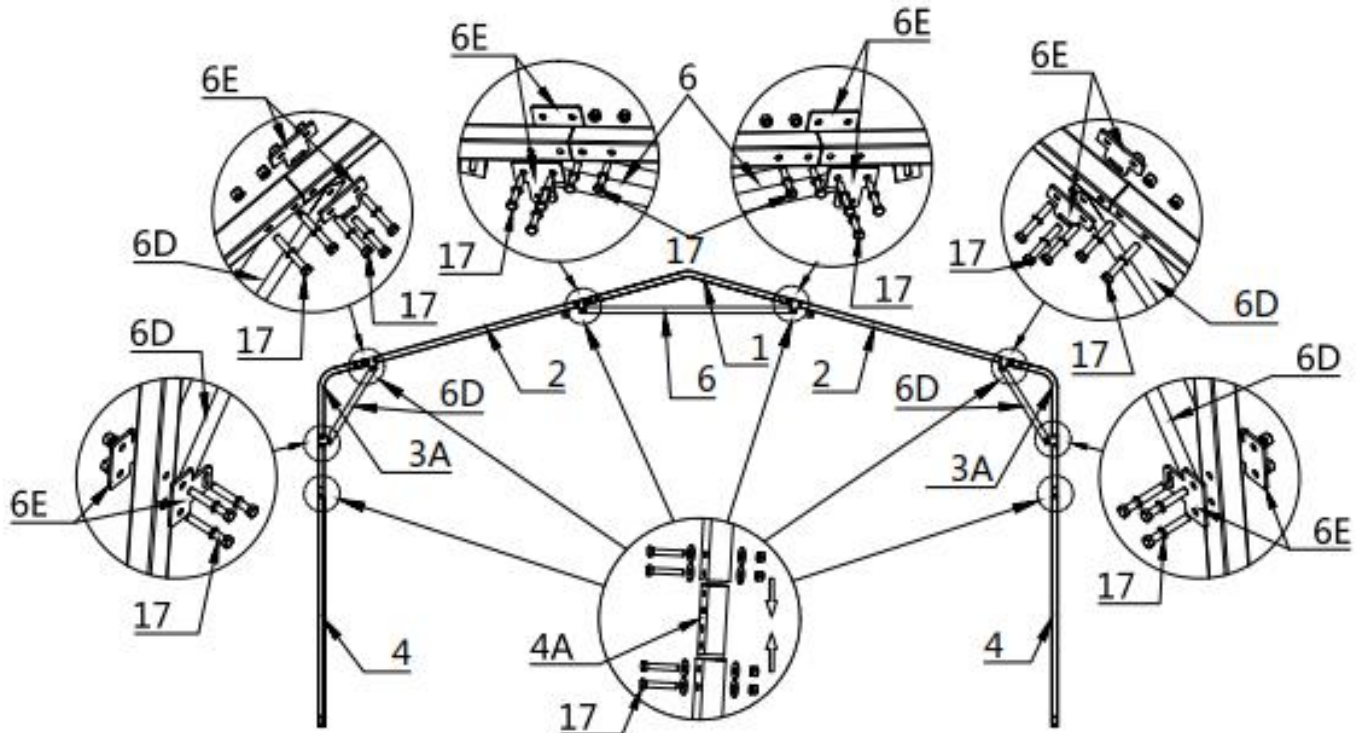
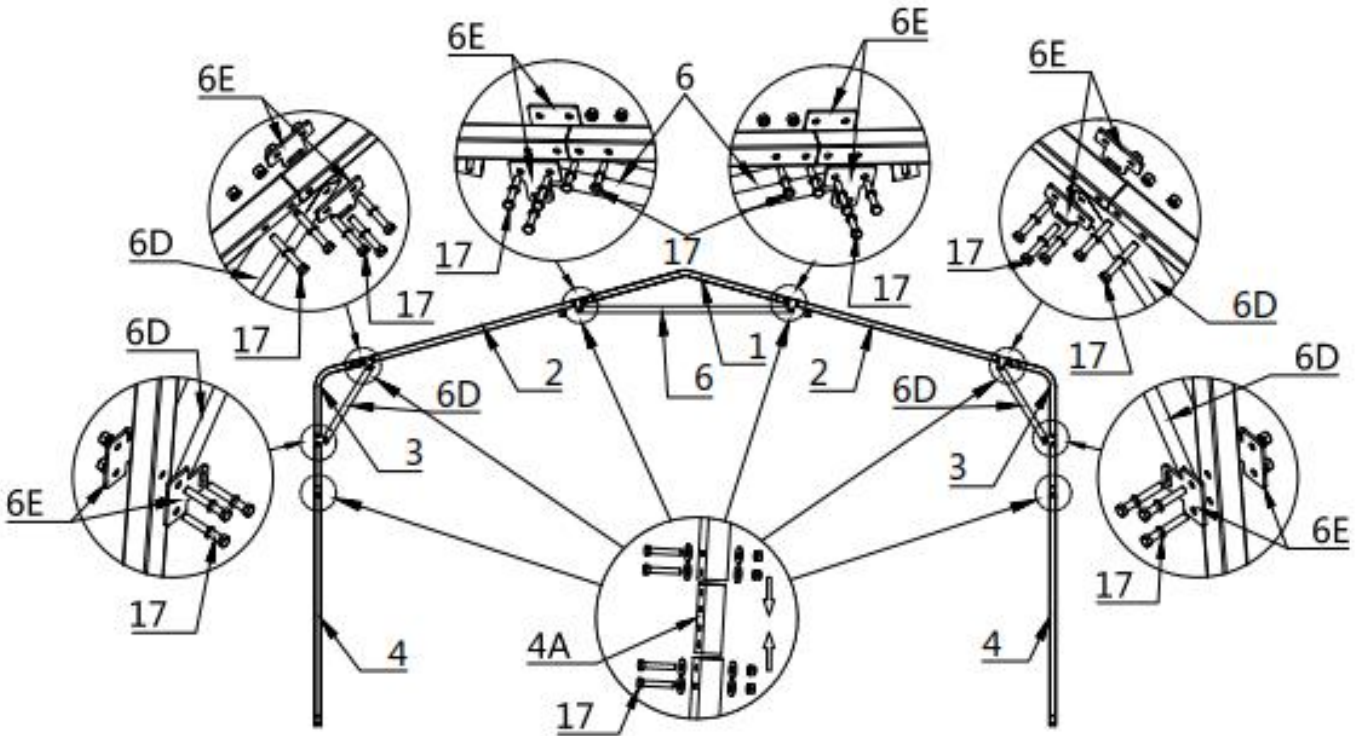

Figure 3

- Parts used to install (5) middle trusses in this step (refer to figure 4).

- (1x4) Peak arch tube (#1)
- (2x4) Middle rafter tube (#2)
- (2x4) Shoulder tube (#3)
- (2x4) Sidewall tube (#4)
- (34x4) Hex bolt (#17)
- (1x4) Ceiling cross bar (#6)
- (2x4) Reinforcing tube (#6D)
- (12x4) Reinforced tube mounting plate (#6E)
- (6x4) Short casing (#4A)



**Figure 4**

- Lay down all (7) trusses on the ground when the assembly is all completed and before moving to next step (refer to figure 5).

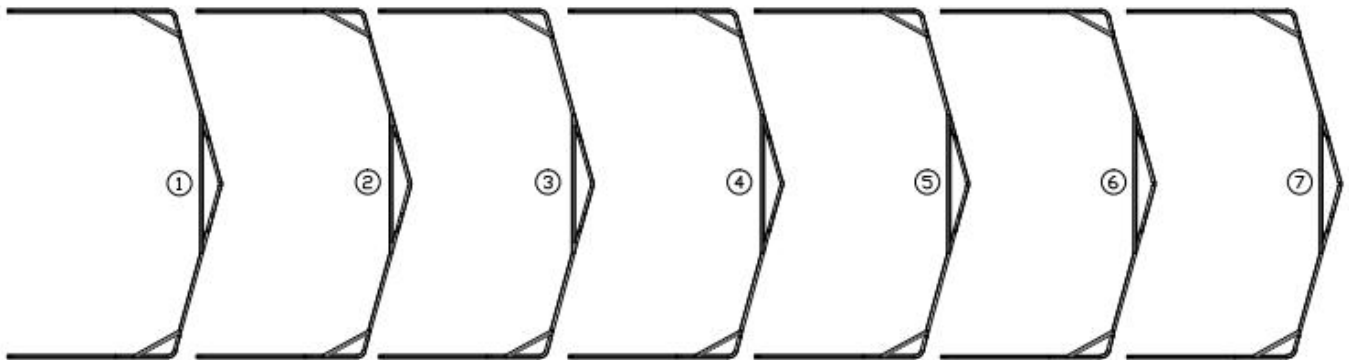

**Figure 5**

### **Step 3 : Assemble all trusses to the foundation pipe and connect them with (#17) bolts**

- The front and rear trusses are installed with one side of (#12) Steel cable mounting plate facing outwards (refer to figure 6).

Parts used in this step :

- (4x7) Hex bolt (#17)



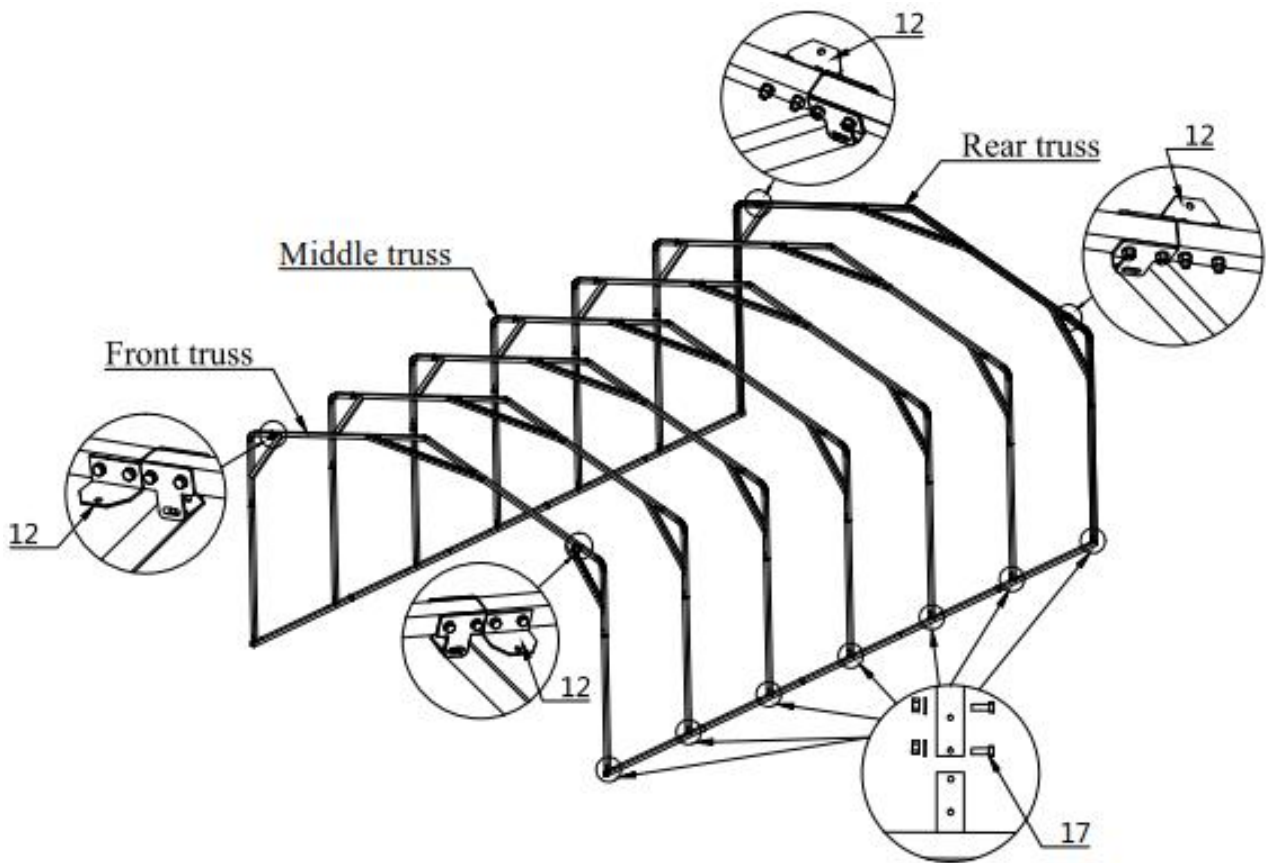
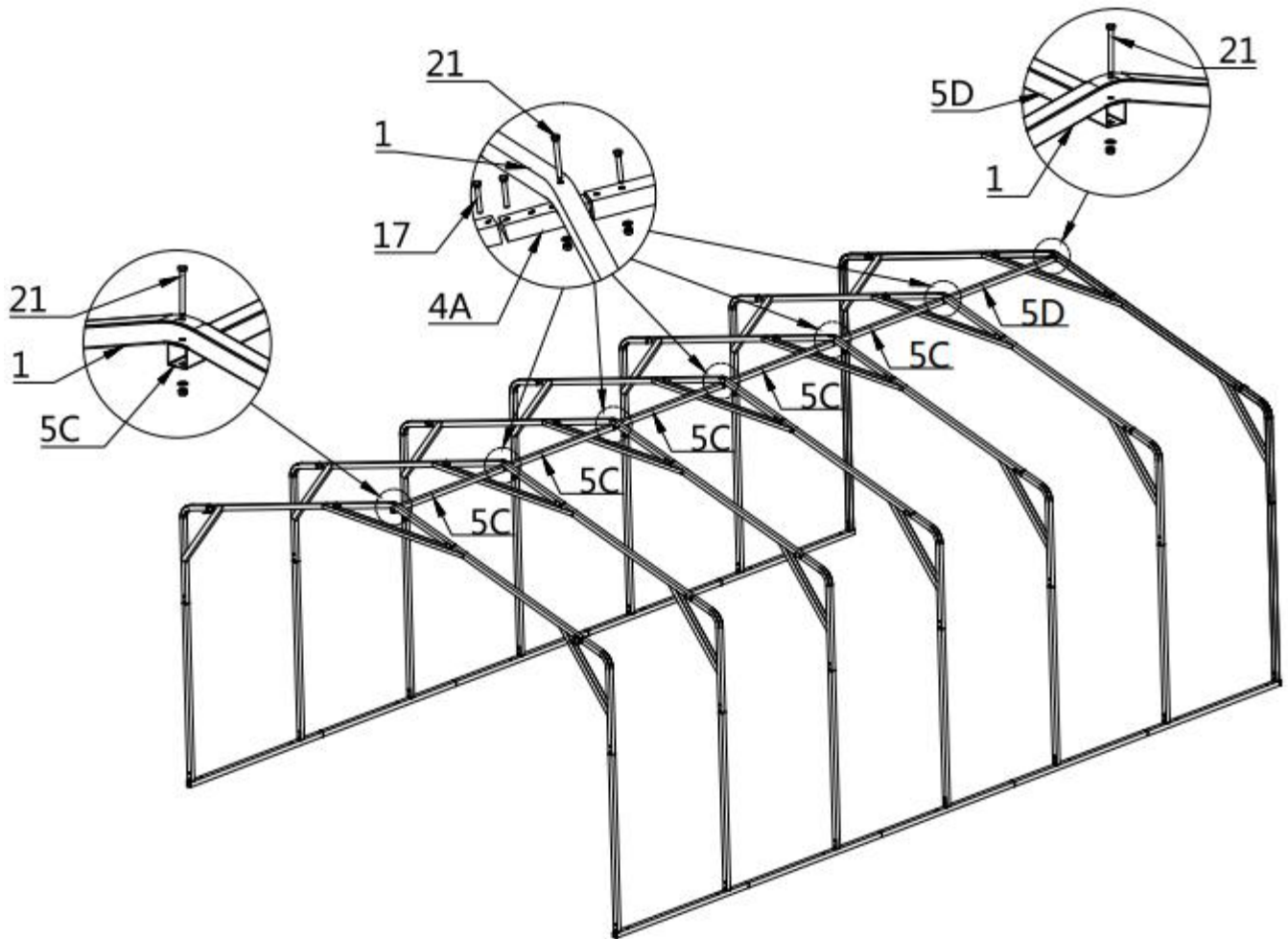

**Figure 6**

- Install top cross bar A (#5C) and top cross bar B (#5D). Use (#21) and (#17) Hexagonal bolt fixation (refer to figure 7).

Parts used in this step :

- (5) Top cross bar A (#5C)
- (1) Top cross bar B (#5D)
- (5) Short casing (#4A)
- (15) Hex bolt (#17)
- (7) Hex bolt (#21)



**Figure 7**

#### **Step 4 : Install the color iron tile**

- Before installation, ensure that the distance between centers of each collapse is 1500mm. Install the first row of colored steel tiles from the top end. The center of the colored steel tiles must be aligned with the midpoint of the top arch tube (you can mark the center of the top arch tube with a line). The extension size of both ends is 50mm. The size of the middle cross overlap position is 95mm, and the cross overlap position needs to be coated with waterproof silicon sealant. All color steel tiles are fixed on the truss with (#18) self tapping screws (refer to figure 8).
- Parts used in this step :
  - (30) Metal sheet (#7)
  - (60) Metal sheet (#8)
  - (340) Self tapping screw (#18)
  - (4) Waterproof silicon sealant (#16)

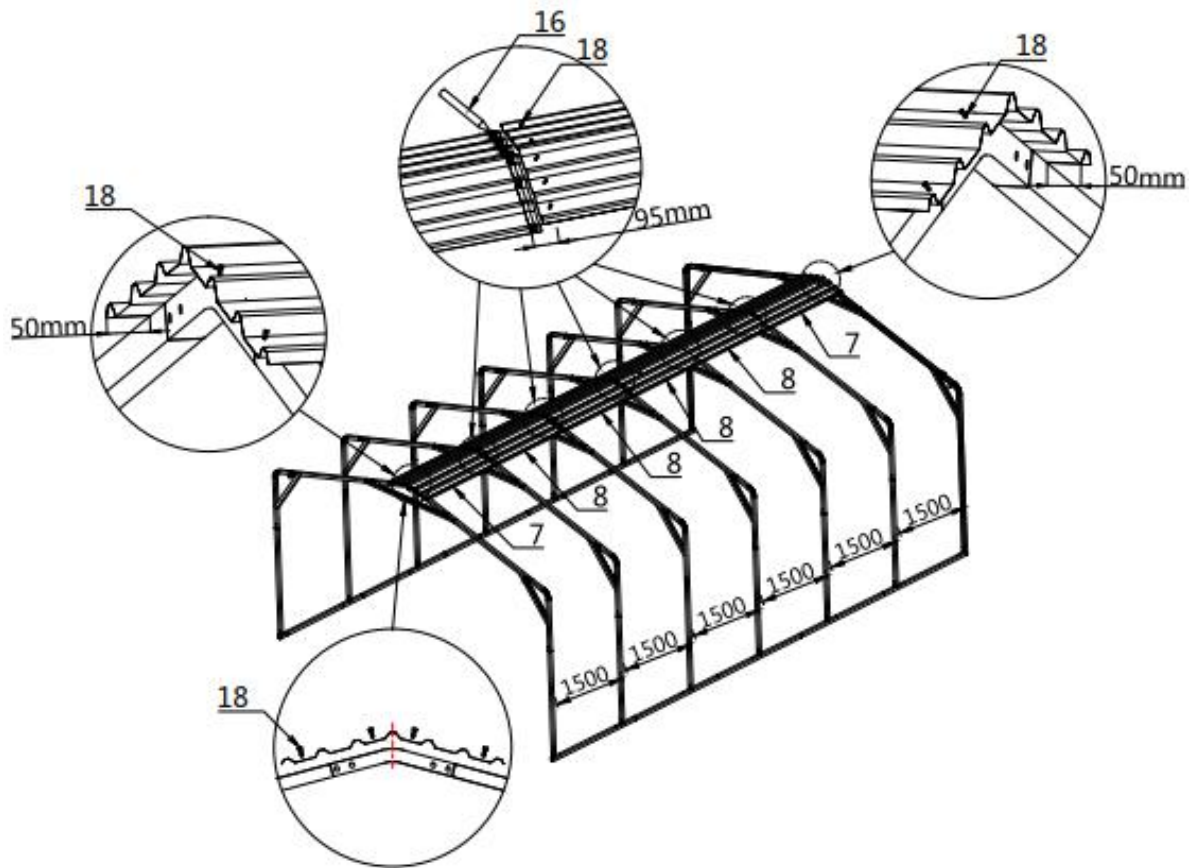

**Figure 8**

- Install the first color steel tile. Take the first colored steel tile at the top as the benchmark, ensure that both ends of each colored steel tile are aligned, and lock it on the truss with (#18) self tapping screw (refer to figure 9).

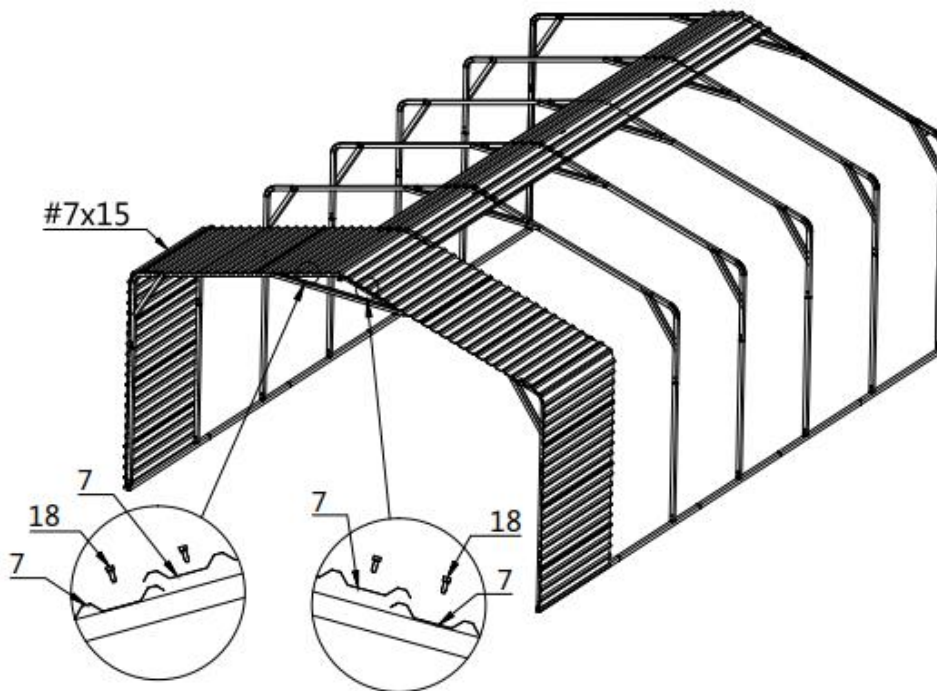

**Figure 9**

- Install all color iron tiles in turn, make sure that both ends of each color iron tile are aligned, and apply waterproof silicon sealant (#16) on the butt joint of both ends (refer to figure 10).

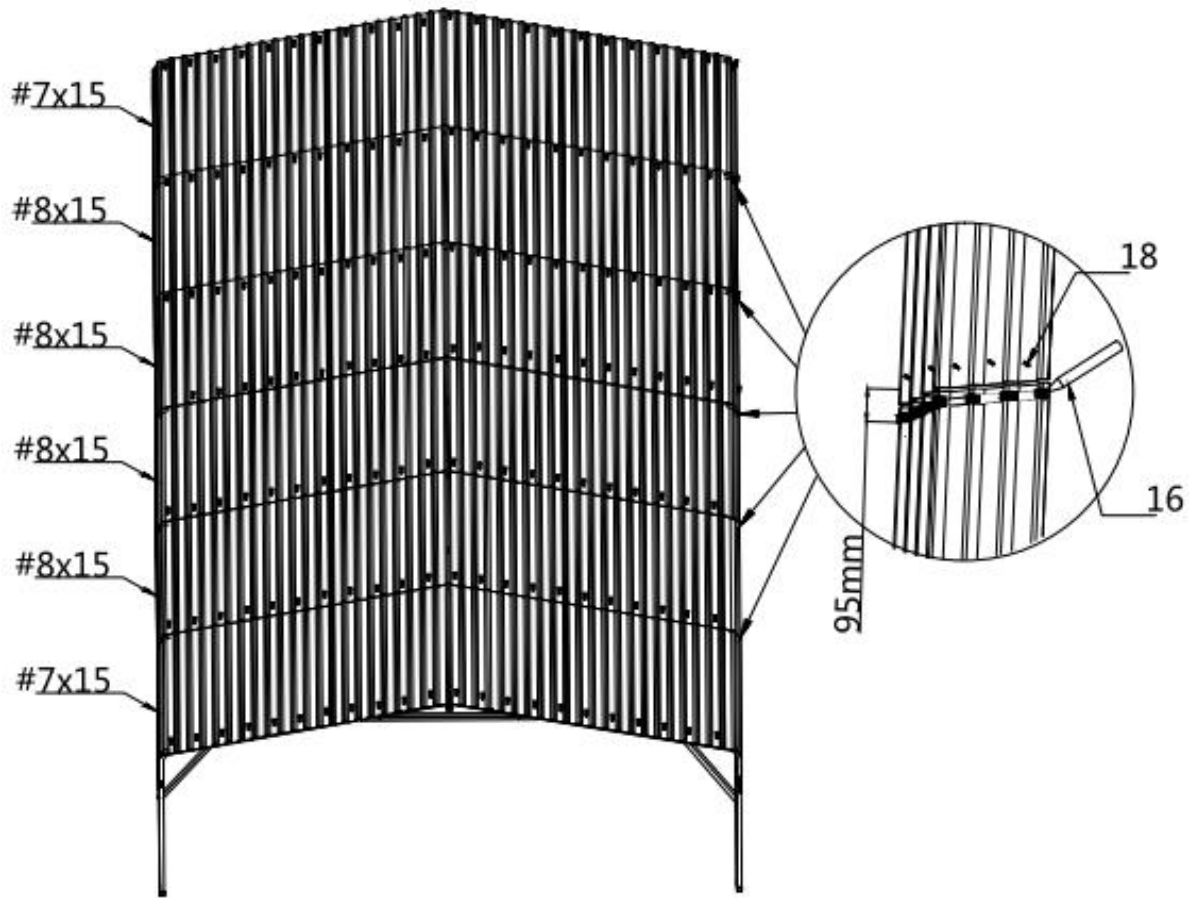

**Figure 10**

### **Step 5 : Install the front and rear edging strips**

- Start to install the color steel tile edge protector (#9A) from one side, and align one end with the color steel tile edge. The opening of the edge banding strip of the color steel tile shall be aligned with the end face of the color steel tile, and the bottom buckle can be pressed into place. It is necessary to use tools to cut out the gap at the corner so that the edge banding strip of color steel tile can be bent and installed (refer to figure 11).
- Parts used in this step :
  - (14) Edge protector (#9A)
  - (12) Edge buckle (#10)

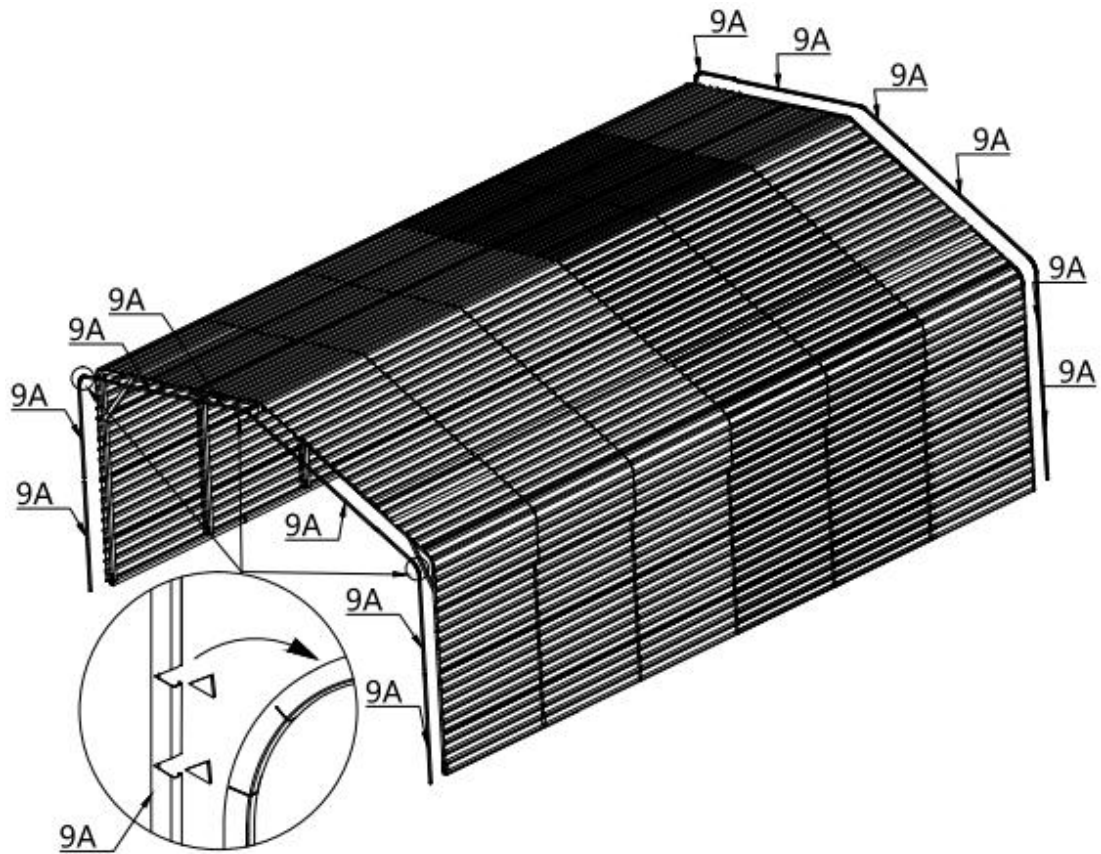

**Figure 11**

- Install the edge buckle (#10) and the two raised card points of the edge buckle are aligned with the square holes at the interfaces of the two color steel tile edge bands, and then press the buckle in place. The front and rear installation methods are the same (refer to figure 12).

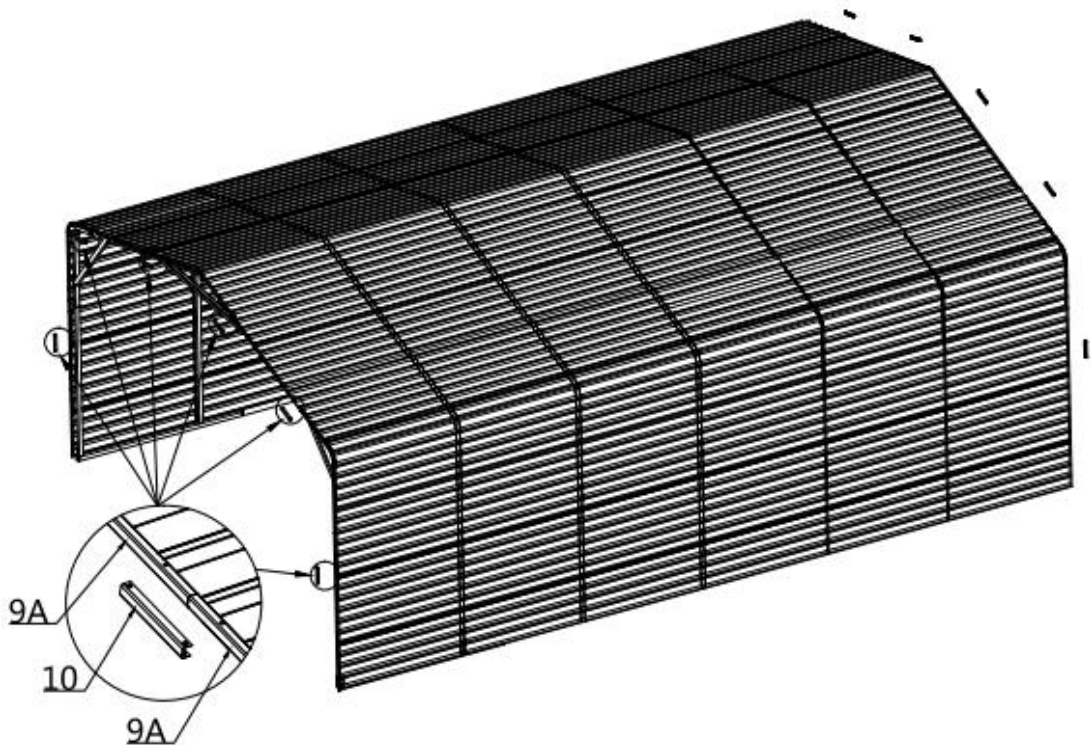

**Figure 12**

## Step 6 : Drilling holes in metal sheet

- Drill holes from inside to outside where the middle truss has holes, through the thin metal sheet (refer to figure 13).

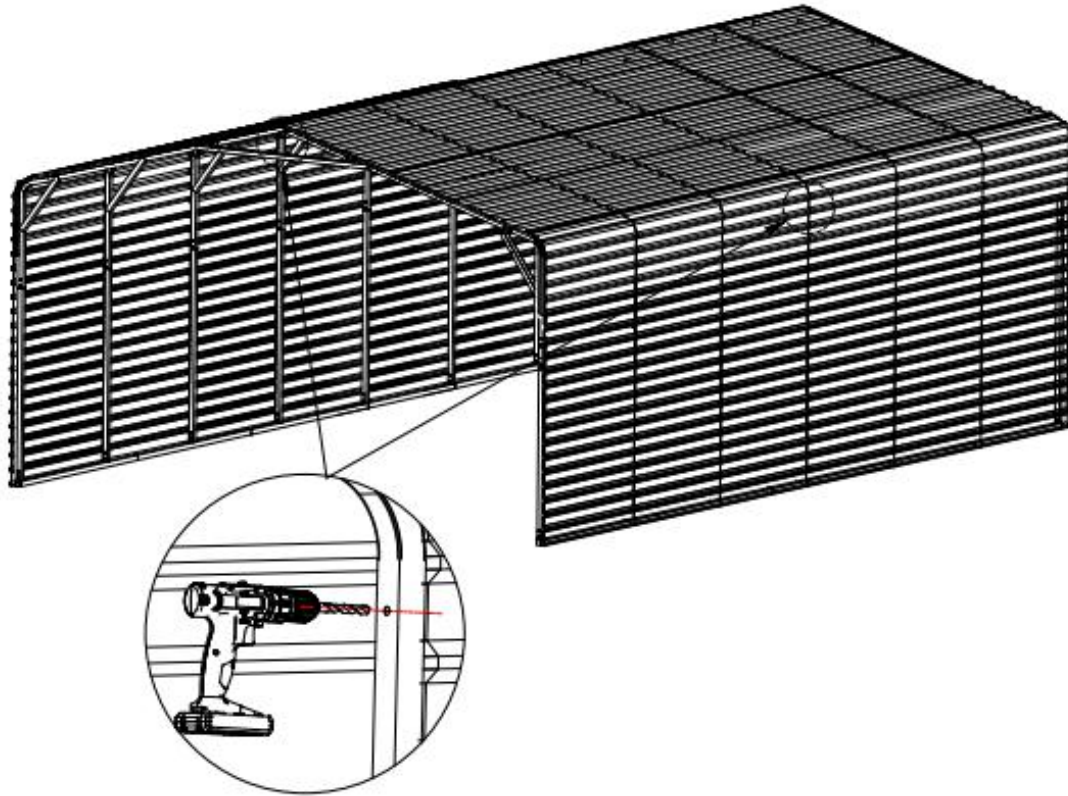
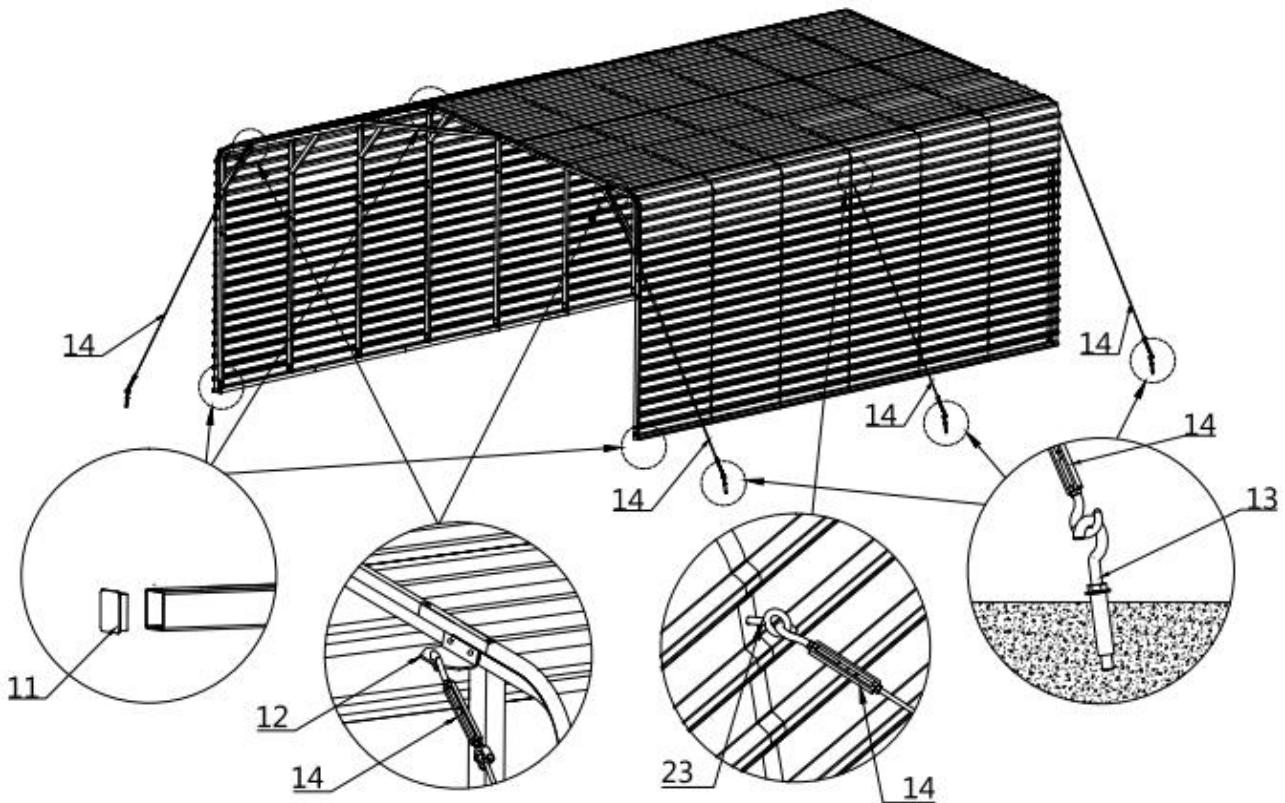

**Figure 13**

## Step 6 : Install wire rope and waterproof plug

Select a suitable position to fix the expansion bolt of the draw hook on the ground, hook one end of the wire rope onto the wire rope mounting plate and eyebolt, and fix the other end to (#13) anchor hook of the draw hook, adjust the nut on the steel wire rope to tighten the steel wire rope. Last, put the waterproof plug into the square pipe head (refer to figure 14).

- Parts used in this step :
  - (6) Anchor hook (#13)
  - (6) Steel cable (#14)
  - (6) Water plug (#11)
  - (2) Steel cable (#23)



**Figure 14**

Now that your building is completely installed, we need to check all components and trusses to make sure the whole structure is rectangular. Check whether the connection of color steel tile fits. We provide (#19) rivets, which can be used to fix the color steel tiles where necessary, so that they can fit together to prevent water leakage.

- All bolts installed in this step can now be tightened. Do not over tighten the bolts, otherwise the pipes or components will be damaged.

### **After the Installation**

Walk around and inspect the shelter periodically to make sure all components are still firmly secured and the whole shelter is well supported. Check all bolts and nuts as well as all connection points to make sure they are all in good position. Check the base plates, adjust the ropes and tie downs if required and clean the cover regularly.

Snow accumulating on the fabric cover must be removed as soon as possible. If snow becomes solid ice on the cover, it will increase the weight on the roof and may collapse the shelter or reduce the life span.

We strongly recommend you remove any snow from the roof immediately. Do not leave any snow load on the roof overnight. Keep 3 feet of clearance on all sides at all times. Do not allow snow to accumulate and pile up on the sides of the building. Otherwise the pressure from the sides will push inwards and could lead to a collapse.