

20 TON SHOP PRESS PNEUMATIC

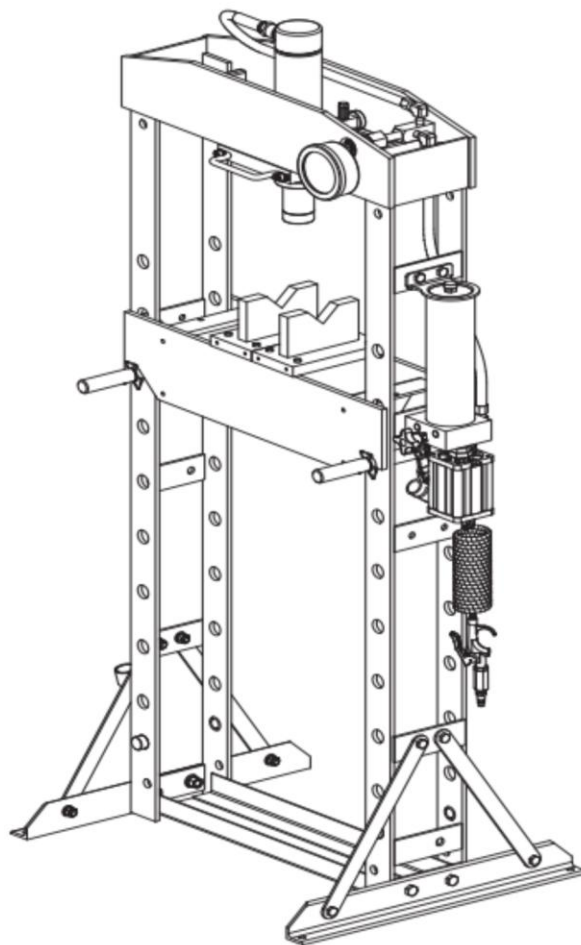

⚠ WARNING



- Please read and understand the product manual completely before assembly
- Check against the parts list to make sure all parts are received
- Wear proper safety goggles or other protective gears while in assembly
- Do not return the product to dealer. They are not equipped to handle your requests.

Missing parts or have questions on assembly?

Please call: 1-877-761-2819 or email: cs@tmgindustrial.com

TECHNICAL SPECIFICATIONS

	DESCRIPTION
Item	TMG-ASP22
Capacity	20TON
Bed Opening	100mm
Work Range	0~900mm
Stroke Length	175mm
Inside Bed Dimensions L x W	150x510mm
Dimensions L x W x H	790x560x1650mm
Hydraulic Oil	ISO VG 15

SAFETY MARKINGS

WARNING!

1. Study, understand, and follow all instructions before operating the device.
2. Do not exceed rated capacity.
3. Prior to use, make sure the press is securely anchored.
4. The press shall be installed and operated in accordance with instructions.
5. Ensure the work area is clean and free of any hazards before operation.
6. Keep hands, arms, feet, and legs out of the work area. Accidental slippage can result in personal injury.
7. Use appropriate guarding to contain any pieces that may break or fly apart when applying force.
8. Use only press accessories having a capacity rating equal to or greater than the capacity of the press.
9. Verify lift cables are slack before pressing on the bolster.
10. Avoid off-center loads.
11. No alterations shall be made to the product.
12. Do not use this press for any use other than the manufacturer specified usage.
13. Failure to heed and understand these instructions and markings may result in personal injury, property damage, or both.

SHOP PRESS PARTS LIST (A)

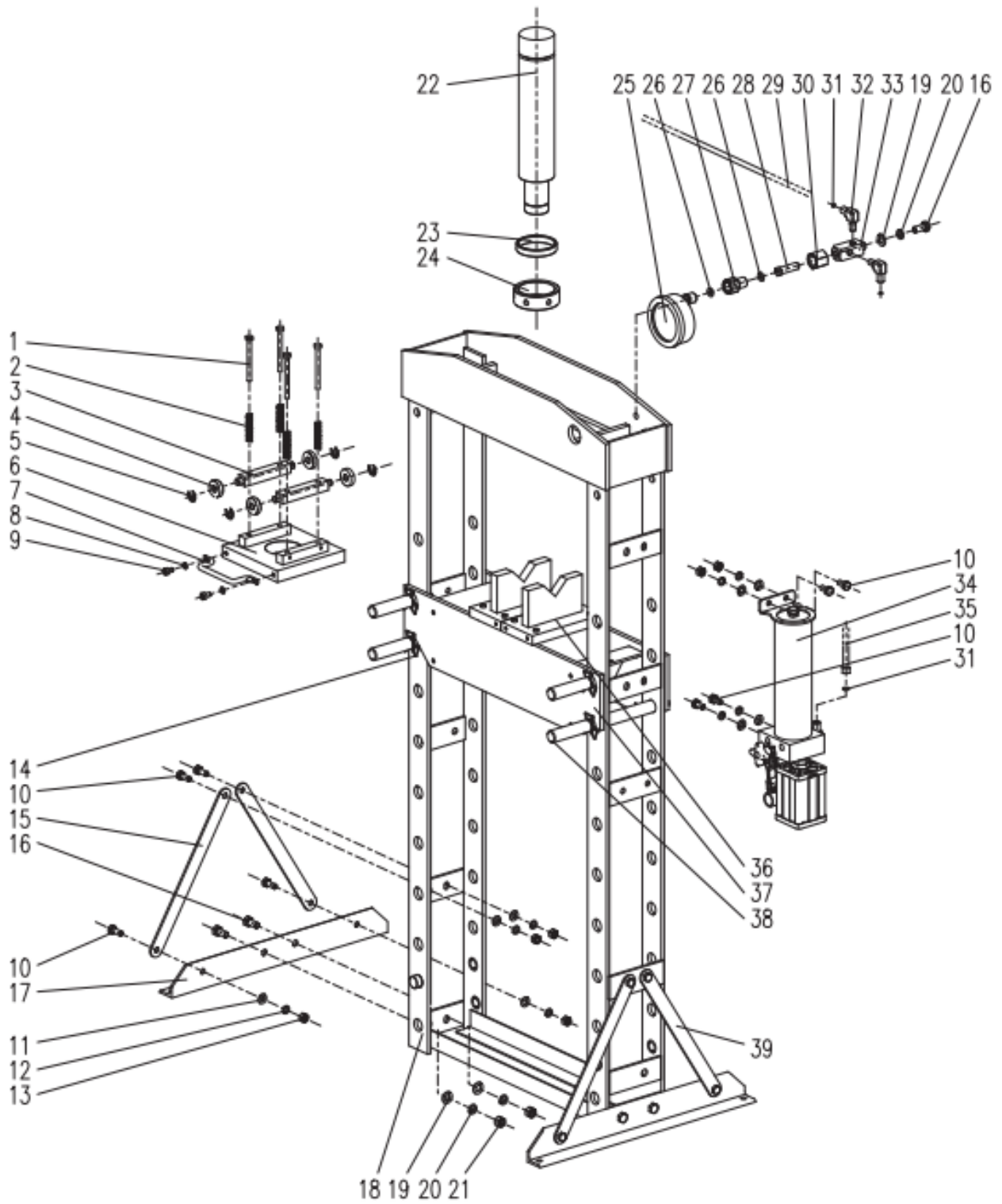

PARTS LIST

SHOP PRESS PARTS LIST (figure A)

NO	DESCRIPTION	QTY
A1	bolt M8x100	4
2A	spring	4
A3	roller shaft	2
A4	bearing	4
A5	ring	4
A6	cylinder fixing plate	1
A7	cylinder moving handle	1
A8	spring washer 8	2
A9	bolt M8x10	2
A10	bolt M10x25	12
A11	washer 10	12
A12	spring washer 10	12
A13	nut M10	10
A14	butterfly washer	4
A15	knighthead	1
A16	bolt M12x25	5
A17	base section	2
A18	frame	1
A19	washer 12	5
A20	spring washer 12	5

NO	DESCRIPTION	QTY
A21	nut M12	4
A22	cylinder parts	1
A23	protecting ring	1
A24	protecting ring	1
A25	pressure gauge	1
A26	rectangular sealing ring	2
A27	pressure gauge connection	1
A28	joint	1
A29	hydraulic hose	1
A30	guage connection nut	1
A31	O-ring	3
A32	straight connector	2
A33	T-connector	1
A34	press pump part	1
A35	hydraulic hose	1
A36	press block	1
A37	bed frame	1
A38	bed frame pin	2
A39	knighthead	3
A40	handle	1

RAM PARTS LIST (B)

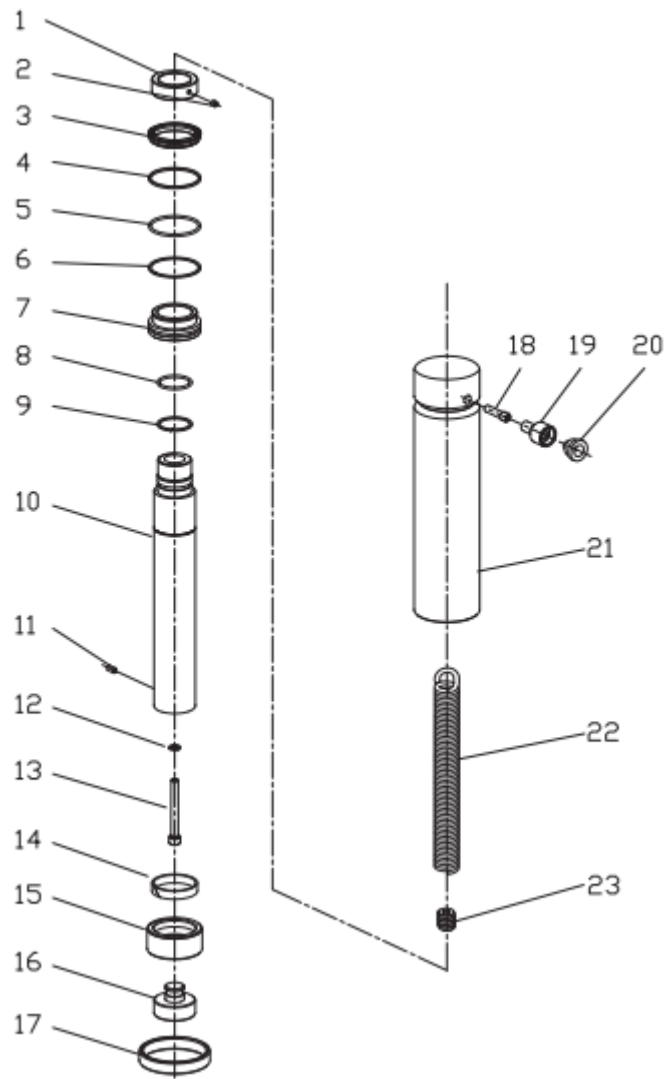

RAM PARTS LIST (figure B)

NO	DESCRIPTION	QTY
B1	Description	1
B2	spacing ring	1
B3	Y-ring	1
B4	back ring	1
B5	O-ring	1
B6	nylon ring	1
B7	piston ring	1
B8	O-ring	1
B9	ring	1
B10	piston	1
B11	screw M6X10	1
B12	sealing washer	1

NO	DESCRIPTION	QTY
B13	bolt M8X70	1
B14	guide ring	1
B15	upper collar	1
B16	toe	1
B17	lower securing collar	1
B18	bolt	1
B19	coupler	1
B20	dust cap	1
B21	cylinder	1
B22	spring	1
B23	spring nut	1

PUMP PARTS LIST (C)

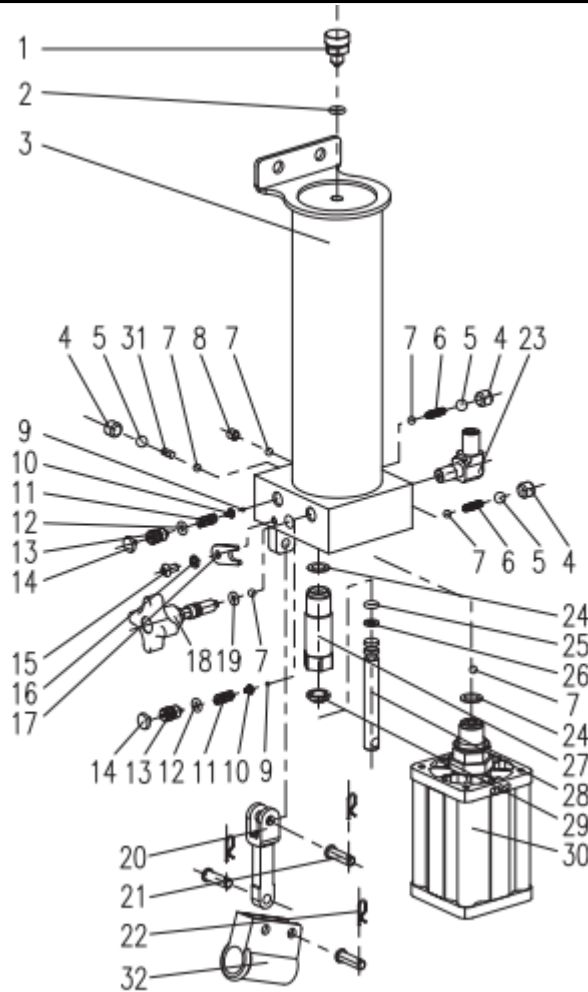

RAM PARTS LIST (figure C)

NO	DESCRIPTION	QTY
C1	Air bleed screw	1
C2	O-ring	1
C3	Hydraulic pump unit	1
C4	M12X1.25X10	3
C5	Ball valve	3
C6	Steel ball Spring	2
C7	Ball valve	5
C8	M8x8	1
C9	Ball valve	2
C10	Spring plate	2
C11	Spring safety valve	2
C12	O-ring	2
C13	Pressure adjusting screw	2
C14	Safety valve cap	2
C15	Bolt M6X10	1
C16	Spring washer6	1

NO	DESCRIPTION	QTY
C17	Limit block	1
C18	Release valve lever	1
C19	O-ring	1
C20	connecting rod	1
C21	Pin	3
C22	Tensional spring latch	3
C23	Angle coupling	1
C24	Copper pad	2
C25	O-ring	1
C26	Ring	2
C27	Pump body	1
C28	Pump unit	1
C29	J-ring	1
C30	Air pump	1
C31	Steel ball pin	1
C32	Hand-held	1

ASSEMBLY INSTRUCTIONS

Use the exploded drawing as your guide to assemble. Lay all parts and assemblies out in front of you before beginning.

The following procedure is recommended:

- Attach one base section (17) to left post using bolts (16) washers (19) lock washers (20) and nuts (21) then attach another to right post.
- Fix one end of knighthead (15) to the base section (17) and another end to the frame (18) using bolts (10) washers (11) lock washers (12) and nuts (13).
- Insert bed frame pin (38) into the holes in the frame, then insert the joined press bed frame (37) into press frame and onto bed frame pin.
- Attach the pump assembly (34) to the right post using bolt (10), washers(11) lock washers (12) and nuts (13), then insert the handle to the handle bracket.
- Connect the hydraulic hose (35) to the pump assembly (34) and assemble the pressure gauge (25) to the pressure gauge connection nut (27).
- Tighten all bolts and screws.

BEFORE FIRST USE

IMPORTANT: BEFORE FIRST USE

- All numbers in parenthesis () refer to the index number from the parts breakdown.
- Perform the following Air Purge Procedure to remove any air that may have been introduced into the hydraulic system as a result of product shipment and handing. This step is to be completed without and weight on the jack.

SYSTEM AIR PURGE PROCEDURE

THIS PRODUCT HAS COMPLETED THE AIR PURGE PROCEDURE BEFORE LEAVING THE FACTORY AND CAN BE USED DIRECTLY

- Check all parts and conditions, if there is any part broken, stop using it and contact your supplier immediately.

1. Firmly close the Release Valve by turning it clockwise.

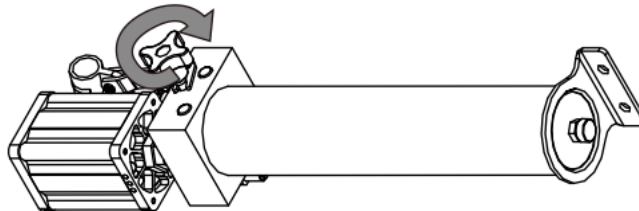

2. Remove the hydraulic cylinder end of the hydraulic hose and press the tip of the Coupling against a hard surface and pump the pump handle.

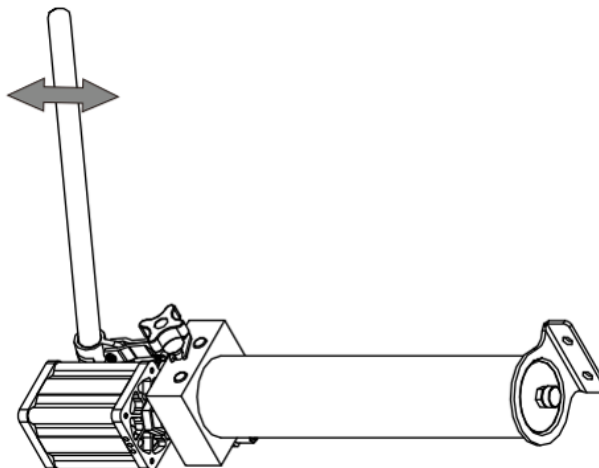

3. Continue pumping until the hydraulic fluid starts to come out from the end of the coupler tip and is free of air bubbles.

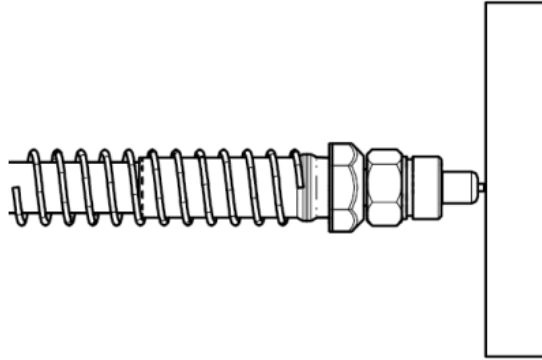

4. Check the oil level and add oil if necessary.(See instructions how to add oil.)

5. Turn the Release Valve counterclockwise to release the pressure in the pump and hose.

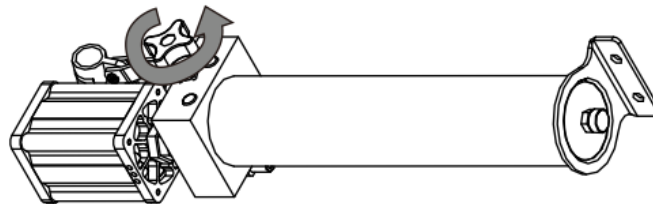

OPERATING INSTRUCTIONS

WARNING! ENSURE THAT YOU READ, UNDERSTAND AND APPLY THE SAFETY INSTRUCTIONS AND WARNINGS BEFORE USE.

- Place the heel block on press bed frame, then insert work piece onto the heel block.
- Close the release valve by turning it clockwise until it is firmly closed.
- Pump the handle until serrated saddle nears work piece.
- Align work piece and ram to ensure center-loading.
- Pump the handle to apply load onto work piece.
- When work is done, stop pumping the handle, slowly and carefully remove load from work piece by turning the release valve counterclockwise in small increments.
- Once ram has fully retracted, remove workplace from bed frame.
- If you want to more press Englander (01) to loosen the it screws, work to tighten the four screws.

MAINTENANCE

- Clean the outside of the press with dry, clean and soft cloth and periodically lubricate the joints and all moving parts with a light oil as needed.
- When not in use, store the press in a dry location with ram and piston fully retracted.
- When press efficiency drops, purge always air from hydraulic system as described before.
- Check the hydraulic oil; remove the oil filler nut on the top of the reservoir, if the oil is not adequate, fill with high quality hydraulic jack oil until full, then replace the oil filler nut, purge away air from the hydraulic system.