

20 GALLON PARTS WASHER

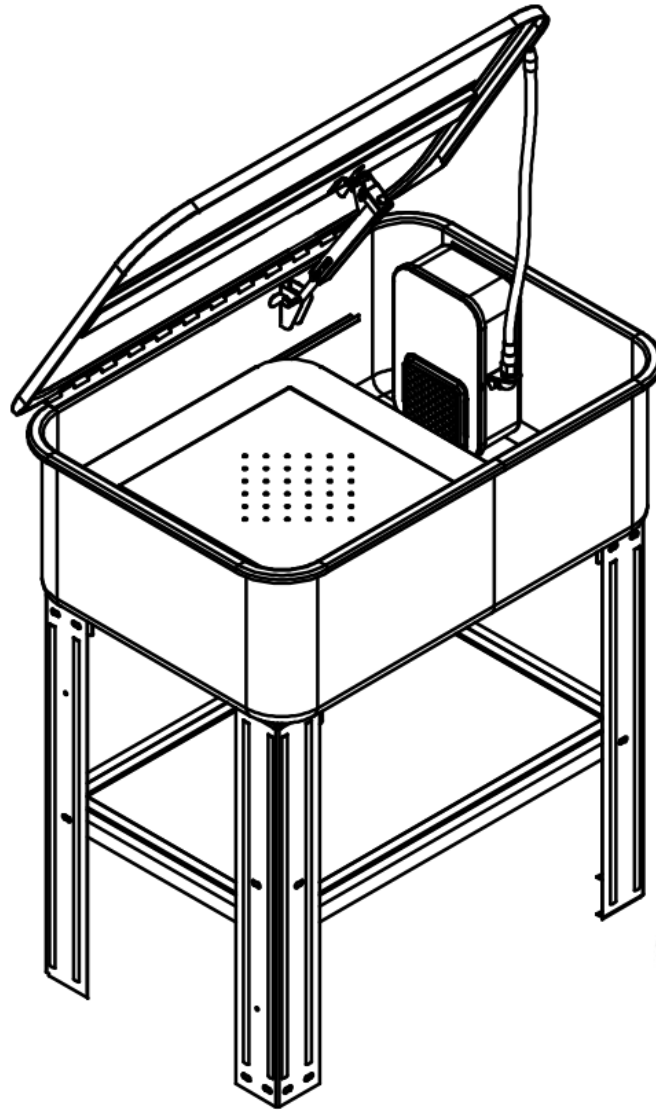

⚠ WARNING

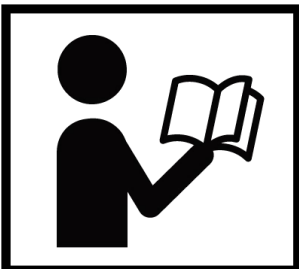

- Please read and understand the product manual completely before assembly
- Check against the parts list to make sure all parts are received
- Wear proper safety goggles or other protective gears while in assembly
- Do not return the product to dealer. They are not equipped to handle your requests.

Missing parts or questions on assembly?

Please call: 1-877-761-2819 or email: cs@tmgindustrial.com

TABLE OF CONTENTS

TABLE OF CONTENTS	2
SAFETY INFORMATION.....	3
SPECIFICATION.....	6
COMPONENTS AND CONTROLS.....	6
UNPACKING & ASSEMBLY.....	7
OPERATION.....	8
CARE & MAINTENANCE.....	10
TROUBLESHOOTING.....	10
PARTS DIAGRAM.....	11

IMPORTANT SAFETY INFORMATION



Before operating the PARTS WASHER read the following safety instructions. Failure to comply with these warnings may result in serious injury or death.

SAFETY INSTRUCTIONS

The alert symbol is used throughout this manual and on the product safety decals. This symbol indicates attention is required and identifies hazards concerning your personal safety and the safety of others. Please follow the recommended precautions



The safety alert symbol means...
ATTENTION! BECOME ALERT! YOUR SAFETY IS INVOLVED!



DANGER

This notice indicates an immediate and specific hazard that will result in severe personal injury or death if the proper precautions are not taken.



WARNING

This notice indicates a specific hazard or unsafe practice that could result in severe personal injury or death if the proper precautions are not taken.



CAUTION

This notice indicates a potentially hazardous situation that may result in minor or moderate injury if proper practices are not taken.

NOTICE - This notice indicates that a specific hazard or unsafe practice will result in equipment or property damage, but not personal injury.

INTRODUCTION

The 20 Gallon Parts Washer is ideal for cleaning grimy parts with water- based solvents. It has a steel flex nozzle and lid with an electrical safety link in the hinge.

SAFETY



WARNING!

Read and understand all instructions before using this tool. The operator must follow basic precautions to reduce the risk of personal injury and/or damage to the equipment.

Keep this manual for safety warnings, precautions, operating or inspection and maintenance instructions.

WORK AREA

1. Operate in a safe work environment. Keep your work area clean, well- lit and free of distractions. Place lights so you are not working in a shadow.
2. Keep anyone not wearing the appropriate safety equipment away from the work area.
3. Store unused tools properly in a safe and dry location to prevent rust or damage. Lock tools away and keep out of the reach of children.
4. Do not install or use in the presence of flammable gases, dust or liquids.
5. Do not use near heat or spark sources such as heaters, open flames or tools that produce sparks.

PERSONAL SAFETY



WARNING!

Wear personal protective equipment approved by the Canadian Standards Association (CSA) or American National Standards Institute (ANSI).

Personal protective equipment

1. Always wear impact safety goggles that provide front and side protection for the eyes. Eye protection equipment should comply with CSA Z94.3-07 or ANSI Z87.1 standards based on the type of work performed.
2. Wear the appropriate type of full-face shield in addition to safety goggles, as the work can create molten, acid or chemical splashes.
3. Wear gloves that provide protection based on the work materials or to reduce the effects of tool vibration.
4. Wear protective clothing designed for the work environment and tool.
5. Non-skid footwear is recommended to maintain footing and balance in the work environment.

Personal precautions

Control the tool, personal movement and the work environment to avoid personal injury or damage to tool.

1. Do not operate any tool when tired or under the influence of drugs, alcohol or medications.
2. Avoid wearing clothes or jewelry that can become entangled with the moving parts of a tool. Keep long hair covered or bound.
3. Do not overreach when operating a tool. Proper footing and balance enables better control in unexpected situations.

SPECIFIC SAFETY PRECAUTIONS



WARNING!

DO NOT let comfort or familiarity with product (gained from repeated use) replace strict adherence to the tool safety rules. If you use this tool unsafely or incorrectly, you can suffer serious personal injury.

1. Use the correct tool for the job. This tool was designed for a specific function. Do not modify or alter this tool or use it for an unintended purpose.
2. Do not use the tool if any parts are damage broken or misplaced. Repair or replace the parts.
3. Only use water-based solvents with the parts washer.

4. Do not modify the washer lid or the lid arm to keep the lid open. Heat from a fire will melt the fusible link and the washer lid will automatically fall to smother the flames.
5. Use the parts washer in a well-ventilated area to avoid fume build up from the solvent.

ELECTRICAL SAFETY



WARNING!

To reduce risk of electric shock, be certain that the plug is connected to a properly grounded receptacle.

1. Disconnect the tool from the power supply before making any adjustments, changing accessories, cleaning, servicing or when storing. Such preventive safety measures reduce the risk of starting the tool accidentally
2. Protect yourself against electric shocks when working on electrical equipment. Avoid body contact with grounded surfaces. There is an increased chance of electrical shock if your body is grounded.
3. Do not disconnect the power cord in place of using the power switch. This will prevent an accidental start-up when the power cord is plugged into the power supply.
 - a. In the event of a power failure, turn off the machine as soon as the power is interrupted. The possibility of accidental injury could occur if the power returns and the unit is not switched off.
4. Do not alter any parts of the tool or accessories. All parts and accessories are designed with built-in safety features that may be compromised if altered.
5. Make certain the power source conforms to requirements of your equipment (see Specifications).
6. This tool is only for use on 120 V (single phase) and is equipped with a three-prong grounded power supply cord and plug. Check with a qualified electrician if you are in doubt as to whether the outlet is properly grounded. If the tool should electronically malfunction or break down, grounding provides a low resistance path to carry electricity away from the user.
 - a. Never remove the grounding prong or modify the plug in any way, as this will render the tool unsafe.
 - b. Do not use any adapter plugs.



WARNING! All wiring should be performed by a qualified electrician.

POWER CORD

1. Insert the power cord plug directly to the power supply whenever possible. Use extension cords or surge protectors only when the tools power cord cannot reach a power supply from the work area.
 - a. When operating a tool outside, use an outdoor extension cord marked W-A or W. These cords are rated for outdoor use and reduce the risk of electric shock.
 - b. Use in conjunction with a Ground Fault Circuit Interrupter (GFCI). It is recommended that the GFCI should have a rated residual current of 30 mA or less.
2. Do not operate this tool if the power cord is frayed, damaged or poorly spliced, as an electric shock may occur, resulting in personal injury or property damage.
 - a. Inspect the tools power cord for cracks, fraying or other faults in the insulation or plug before each use.
 - b. Discontinue use if a power cord feels more than comfortably warm while operating the tool.
3. Keep all connections dry and off the ground to reduce the risk of electric shock. Do not touch the plug with wet hands.
4. Prevent damage to the power cord by observing the following:
 - a. Do not pull on the cord to disconnect the plug from an outlet.
 - b. Keep the cord away from heat, oil, sharp edges or moving parts.
 - c. Never use the cord to carry the tool.
 - d. Place the electrical cord in a position that prevents it from coming into contact with the tool and getting caught by the workpiece. The cord should always stay behind the tool.
5. Do not allow people, mobile equipment or vehicles to pass over unprotected power cords.
 - a. Position power cords away from traffic areas.
 - b. Place cords in reinforced conduits or place planks on either side of the power cord to create a protective trench.
6. Do not wrap the cord around the tool, as sharp edges may cut insulation or cause cracks if wound too tight. Gently coil cord and either hang on a hook or fasten with a device to keep cord together during storage.

PRODUCTS SPECIFICATIONS

Model	TMG-APW20
Tank capacity	20 Gallon
Solvent capacity	12 Gallon
Electric pump	120VAC, 60hz, 0.25A
Flow rate	4GPM
Tank size	28"x19"x10"
Dimensions (L x W x H)	30" x 21" x 35"

COMPONENTS AND CONTROLS

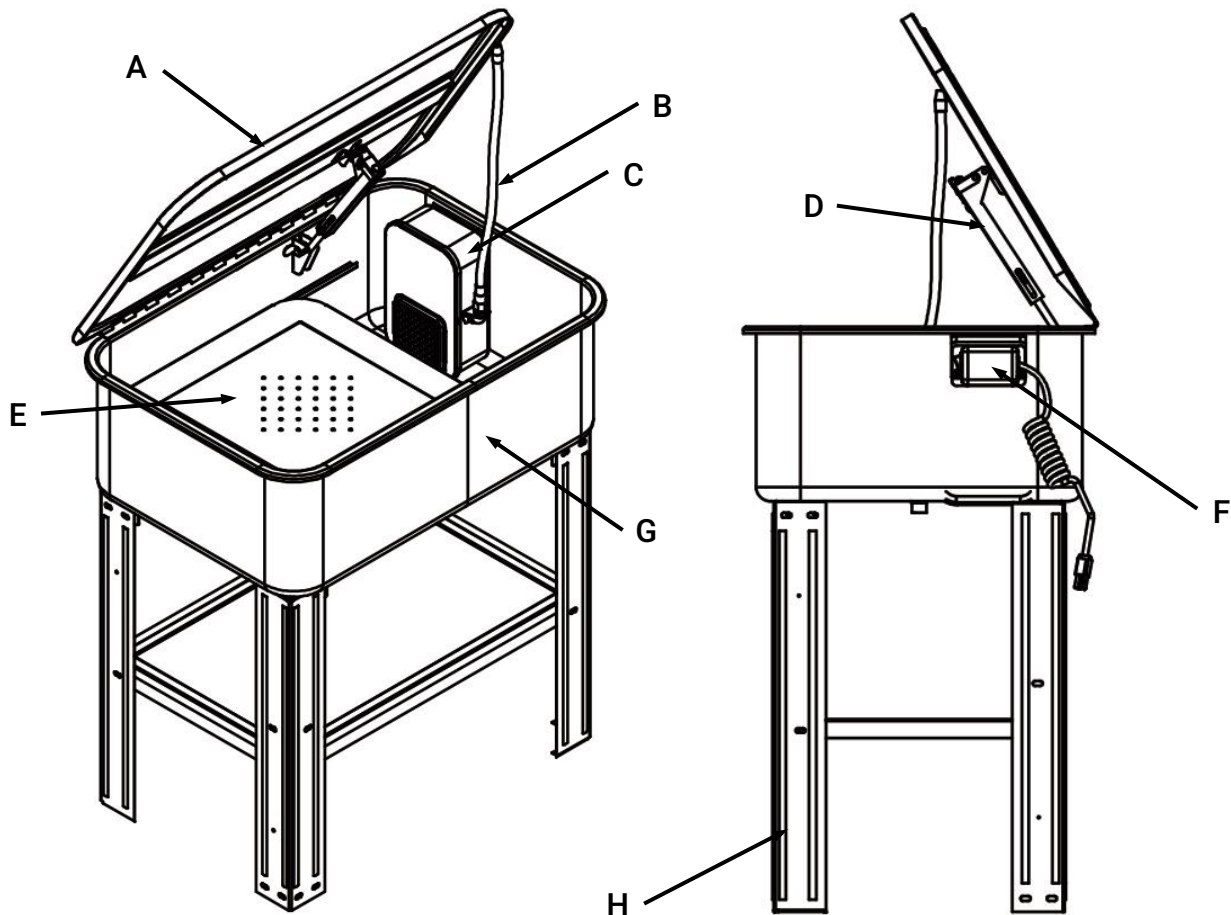

A: Cover
 C: Electric Motor
 E: Work basket
 G: Basin

B: Spray Gun
 D: Safety Hinge
 F: Electric Switch
 H: Leg

UNPACKING & ASSEMBLY

UNPACKING



WARNING!

Do not operate the tool if any part is missing. Replace the missing part before operating. Failure to do so could result in a malfunction and personal injury.

Remove the parts and accessories from the packaging and inspect for damage. Make sure that all items in the parts list are included.

ELECTRICAL CONNECTIONS



WARNING!

Read these electrical safety instructions thoroughly before connecting the product to the mains supply.

Before switching the product on, make sure that the voltage of your electricity supply is the same as that indicated on the rating plate. Connecting it to any other power source may cause damage. This product may be fitted with a non-rewireable plug. If it is necessary to change the fuse in the plug, the fuse cover must be refitted. If the fuse cover becomes lost or damaged, the plug must not be used until a suitable replacement is obtained.

If the plug has to be changed because it is not suitable for your socket, or due to damage, it should be cut off and a replacement fitted, following the wiring instructions shown below. The old plug must be disposed of safely, as insertion into a mains socket could cause an electrical hazard.

ASSEMBLY

1. With spring loaded lid closed, place Tub (7) unit upside down on a non-scratching surface (cardboard, carpet etc.).
2. Attach each of the 4 legs (13) with 4 sets each of 6mm screws (14), washers (8) and locknuts (9) to the brackets on the Tub (7) unit (Fig 1).
3. Attach Storage Tray (12) to holes located mid-way of 4 legs with 2 sets each of 6mm screws(14), washers(8) and locknuts (9) (Fig 2).
4. Return the Tub unit to the upright position on its legs and open the springtensioned lid.
5. Place the Filter (21) inside of the Filter Cover (27). Slide Filter and Filter Cover into place on Pump Housing Cover (28).

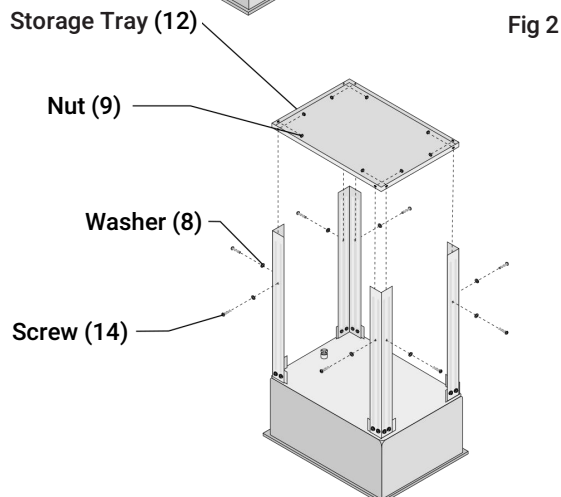
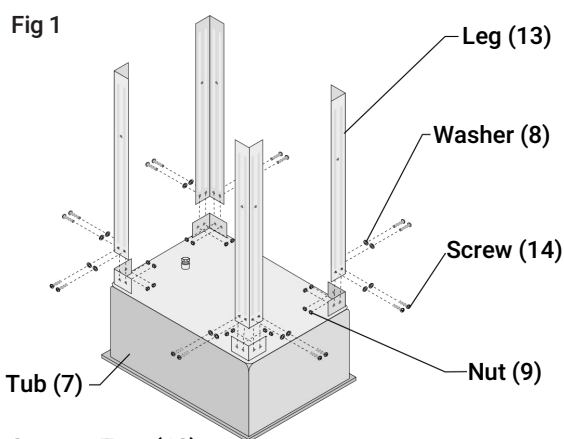

6. Snap the Pump Housing Cover (20) into place on the Pump Housing (28) (Fig 3).
7. Connect the Flexible Pipe (24) to the Elbow (29) (Fig 4).
8. Loosen the two Screws (17) on the Switch Box (23) until there is about a 1/8" gap between the Switch Box (23) and the Pump Housing (28) (Fig 5).
9. Place the Pump Housing (28) inside the Tub (7) so that the bottom lip of the Switch Box (23) hangs outside the Tub and slide it down.
10. Secure the Pump Housing to the Tub by tightening the Switch Box Screws (22).
11. Be sure the Nozzle or Brush outlet is facing in toward the center of the Tub and downward.
12. Fill unit with suitable, water-based degreasing solution sufficiently to cover the entire Inlet Filter (approx. 12 gallons).

Important Note: Follow degreasing solution mixing, usage and safety label instructions carefully before using.

13. Plug power cord into an approved, grounded and GFI equipped Outlet.
14. Turn Power Switch to the "On" position. The Parts Washer is now ready for use.

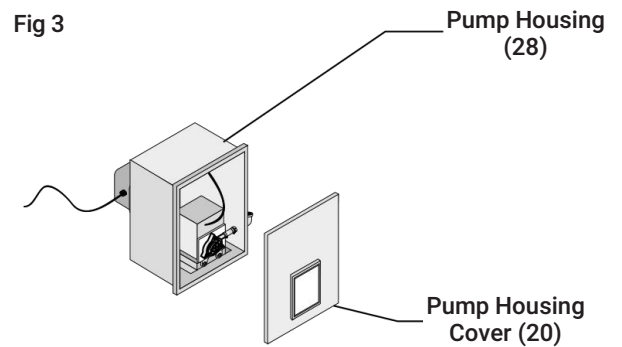

Fig 4

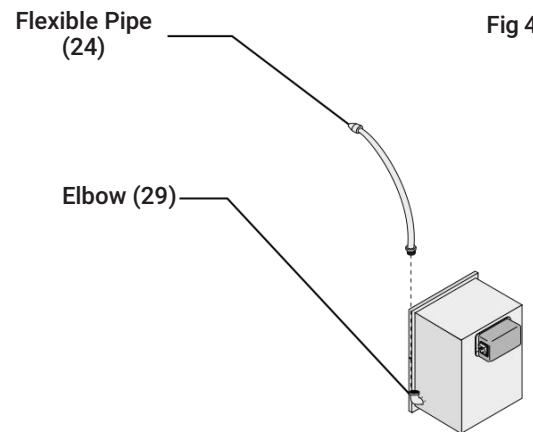
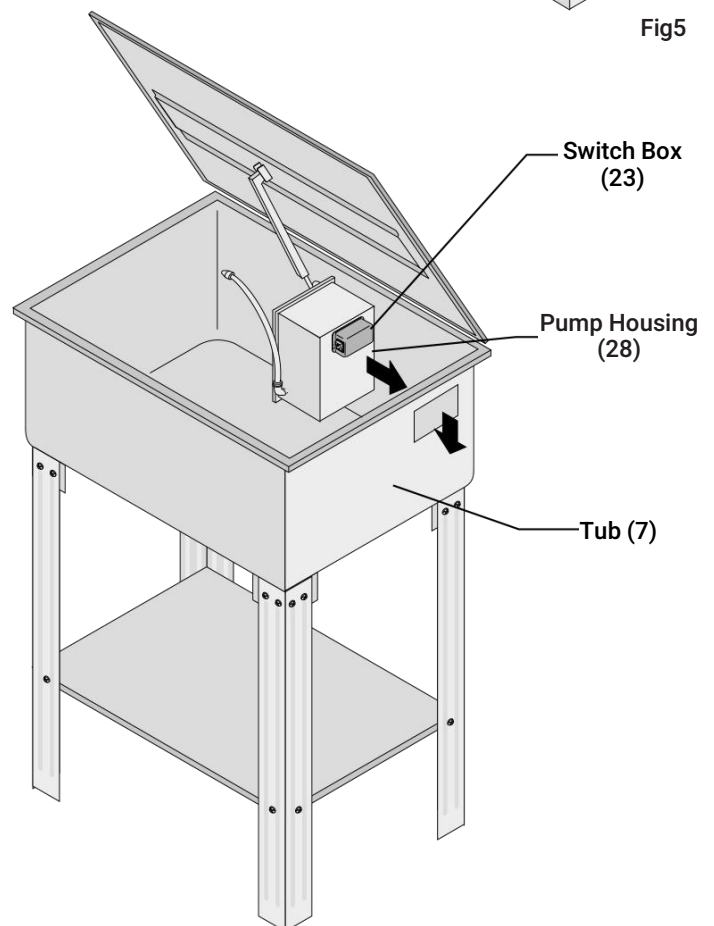

Fig 5



OPERATING

OPERATION



WARNING!

DO NOT use liquids with a flashpoint under 150°F (65°C), such as gasoline, kerosene, ethanol, etc., in the parts washer. The liquid may ignite and cause a fire. Check the manufacturer's Material Data Sheet for the liquid cleaner's flashpoint.



CAUTION!

Wear gloves that will not react with the solvent to protect your hands.

1. Fill the basin (#7) with a water-based solvent. Stop filling before the liquid level reaches the parts tray (#6). The pump must be submerged.
 - a. Only use mild cleaning detergents with a PH of 6 to 8.
2. Place the parts tray and parts basket into the basin.
3. Place the grimy part on the tray.
4. Push the power switch (#22) to start the pump. A stream of liquid will pour out of the spigot. Adjust the spigot as needed.
5. Hold the part to be cleaned under the nozzle, slowly rotate the component until clean.
6. Push the power switch again to stop the flow of liquid.
7. When clean, leave to drain on the tray or in a small component container until dry.
8. Drain the solvent from the tank when washing is complete.
 - a. Position a receptacle that can handle the volume of liquid below the drain. Pull the plug (#11) and empty the basin.
 - b. Store or dispose the solvent based on your local by-laws.
9. Wipe down the tank and parts tray before storing the tool.
10. Remove gloves and goggles, store safely.

Note: Any spillages should be mopped up immediately, so as not to cause a safety hazard.

IMPORTANT:

1. The Lid Stay incorporates a safety device in the form of a fusible link, which closes the lid in the event of fire. The link is non-resetting and must be replaced should it be activated.
2. Clean the pump filter regularly, by sliding it away from the pump housing and rinsing it in clean degreaser.
3. Do not allow the level of liquid in the parts washer to fall below the pump inlet, as damage to the pump can result.

ENVIRONMENTAL PROTECTION

Do not dispose of this product or damaged components with general household waste. All tools, accessories and packaging should be sorted, taken to a recycling centre and disposed of appropriately.

One of the most damaging sources of environmental pollution is oil products. Never throw away used oil with domestic refuse or flush it down a sink or drain. Collect any oil in a leak proof container and take it to your local waste disposal site.



Through purchase of this product, the customer is taking on the obligation to the treatment, recycling & recovery and environmentally sound disposal. In effect, this means that this product must not be disposed of with general household waste. It must be disposed at a recognised disposal facility.

CARE & MAINTENANCE

MAINTENANCE

1. Maintain the tool with care. A tool in good condition is efficient, easier to control and will have fewer problems.
2. Inspect the tool fittings, alignment, hoses and power supply cord periodically. Have damaged or worn components repaired or replaced by an authorized technician. Only use identical replacement parts when servicing.
3. Clean all surfaces inside the tool.
4. Check the pump intake and clean any blockages or material caught in the impeller.
5. Maintain the tool's labels and name plates. These carry important information. If unreadable or missing, contact TMG INDUSTRIAL for replacements.



WARNING!

Only qualified service personnel should repair the tool. An improperly repaired tool may present a hazard to the user and/or others.

DISPOSAL

Recycle a tool damaged beyond repair at the appropriate facility.

Contact your local municipality for a list of disposal facilities or by-laws for electronic devices, batteries, oil or other toxic liquids.

IMPORTANT! DO NOT pollute the environment by allowing uncontrolled discharge of waste oil.

TROUBLESHOOTING

Visit a TMG INDUSTRIAL location for a solution if the tool does not function properly or parts are missing. If unable to do so, have a qualified technician service the tool.

EXPLODED VIEW & PARTS LIST

1. Exploded diagram

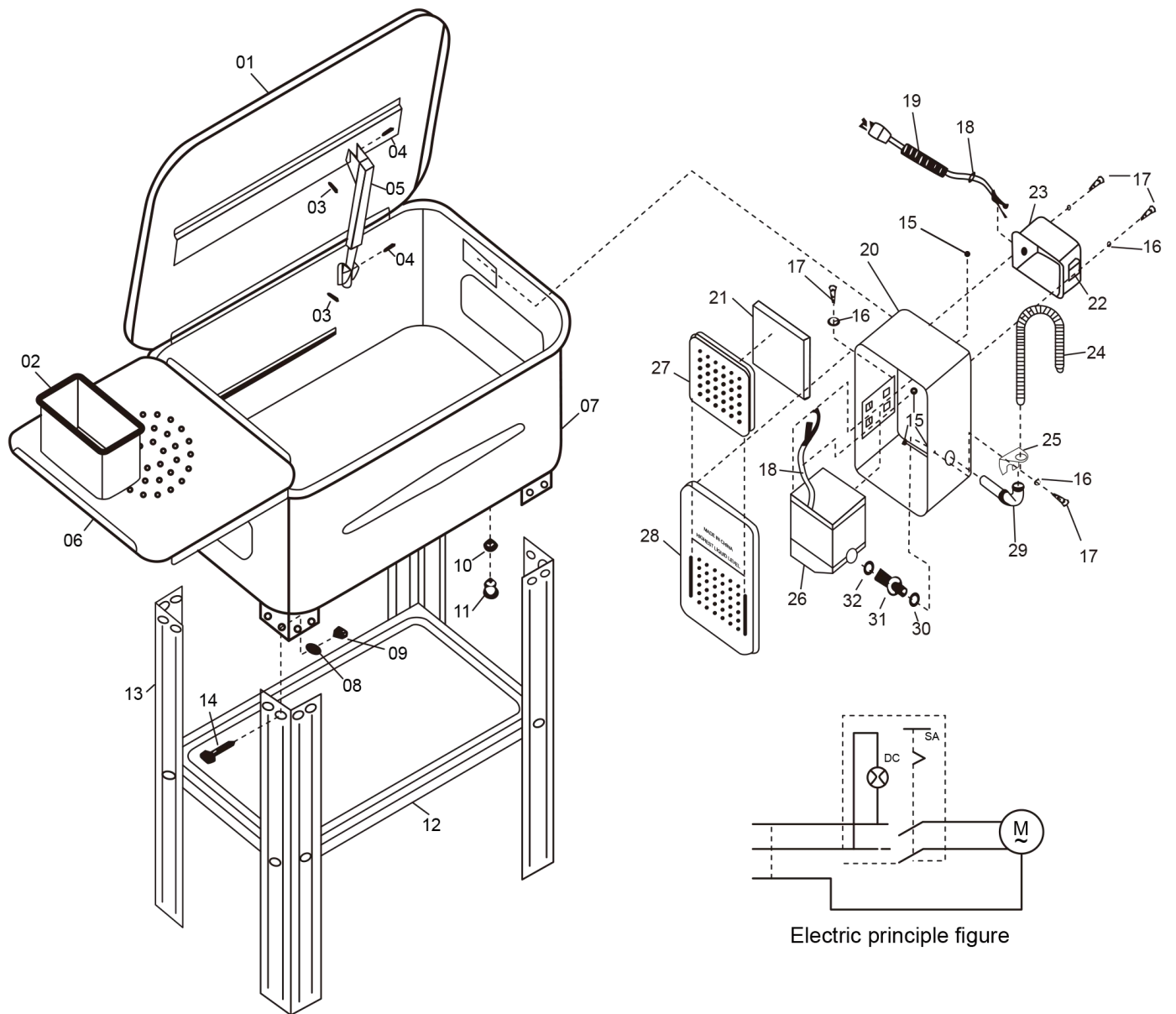

Electric principle figure

2. Parts List

PART NO.	DESCRIPTION	QTY	PART NO.	DESCRIPTION	QTY
1	Cover	1	17	Screw M4x10	6
2	Work basket	1	18	Strain relief	1
3	Spring pin Ø1.6x10	2	19	Cable and plug	1
4	Pin 5x20	2	20	Pump Housing	1
5	Safety hinge	1	21	Filter screen	1
6	Parts tray	1	22	Switch	1
7	Basin	1	23	Switch box	1
8	Spring washer Ø6	24	24	Flexible pipe G1/4"	1
9	Nut M6	24	25	Elbow seat	1
10	O-ring Ø11.8x3.1	1	26	Pump assembly	1
11	Drain plug	1	27	Filter cover	1
12	Shelf	1	28	Pump housing cover	1
13	Leg	4	29	Elbow	1
14	Screw M6x12	24	30	O-ring Ø10x2.65	1
15	Hex nut	6	31	Spigot	1
16	Spring washer Ø4	6	32	Seal ring Ø14x2.65	1