

4 TON LOW PROFILE FLOOR JACK

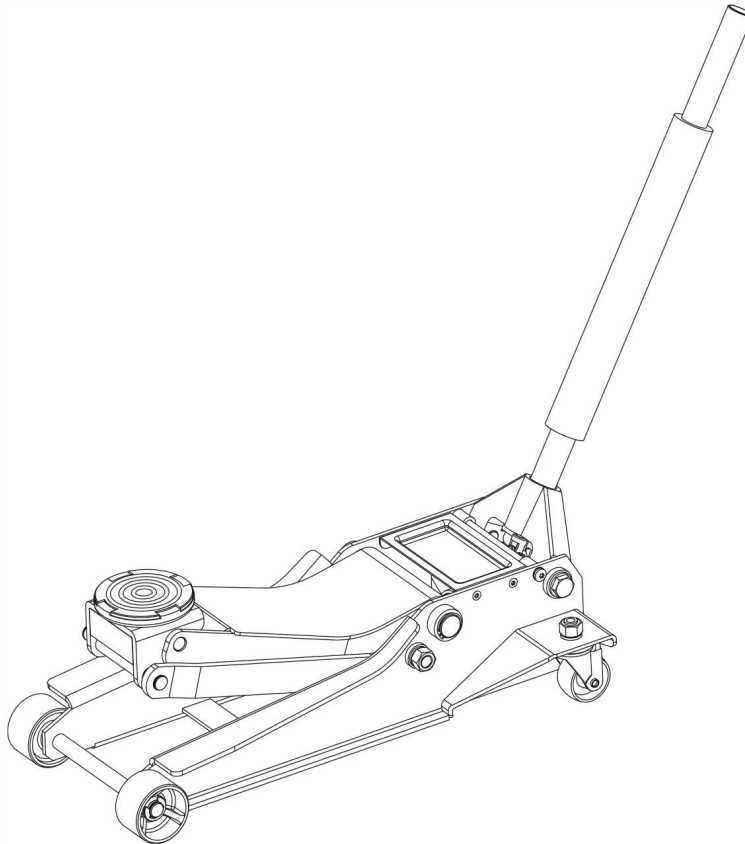

⚠ WARNING



- Please read and understand the product manual completely before assembly
- Check against the parts list to make sure all parts are received
- Wear proper safety goggles or other protective gears while in assembly
- Do not return the product to dealer. They are not equipped to handle your requests.

Missing parts or have questions on assembly?

Please call: 1-877-761-2819 or email: cs@tmgindustrial.com

Please read these instructions carefully before using the product for the first time and store them for future reference. This product must be operated in accordance with these instructions at all times. Make these instructions for use accessible to all persons who will be working with this product. This applies also when reselling the product. We cannot assume any liability for any accidents or damage that may arise due to non-observance of this guide or the safety instructions contained therein. Any structural modifications to the product will void the manufacturer's warranty!

This product is intended for private use only!

Technical specifications

Description:	Garage Jack
Model:	TMG-AJF04L
Nominal load:	max. 4 tonnes
Lifting height:	min. 98 mm to max. 508 mm
Total length:	ca. 726mm
Own weight:	ca. 43.1kg

Made in China

Intended use / safety instructions

This product is a floor jack for lifting motor vehicles. It is intended for use as a lifting device only. Ensure that the load to be lifted does not exceed the maximum permissible load of the jack. The maximum load of 2 tonnes must not be exceeded otherwise the jack may become damaged and safety compromised. Use the jack on a firm, even surface only. Instability or slipping of the load may occur on soft or uneven surfaces. Consequential damage to the vehicle or persons cannot then be precluded. (Risk of accident!). Make sure there are no persons inside the vehicle being lifted. Position the hydraulic jack so that no part of your body will be under the vehicle while it is being lifted. Never work under a car that is being supported only by the hydraulic jack. Always use additional supports. Before lowering the hydraulic jack, ensure there are no persons or objects under the vehicle. Never leave the hydraulic jack unattended for longer periods when it is supporting a load as it can lose pressure and begin to sink for design-related reasons. Therefore place something underneath the lifted load immediately! Never get into the vehicle or start its engine while it is on the hydraulic jack.

WARNING: Lifting of persons prohibited!



General warning sign



Read the manual instruction before using



Do not work under the vehicle when you are using the jack



Work under the vehicle with jack stands



Use the jack on even ground



Use wheel chocks
to secure the wheel



Do not overload



Warning about
hand injuries

General usage instructions

Before using the floor jack, check for loss of oil, damage or missing accessories.

First time operation:

1. Open the drain valve and insert the enclosed handle (extension) in the pumping arm .
To ensure the oil distributes itself completely, carry out approx. 6 full pumps of the handle.
2. Close the drain valve - the vehicle jack is now ready for use.

Lifting the vehicle:

3. Locate your vehicle on an even, firm surface and secure the vehicle against rolling as specified by the vehicle manufacturer.
4. To ensure safe lifting, position the jack at a 90° angle to the vehicle and under the appropriate jacking point (see the manufacturer's instructions).
5. Insert the handle in the drain valve and close it by rotating clockwise until the limit stop is reached.
6. Insert the handle in the pumping arm and pump the handle until the saddle is in contact with the vehicle.
7. Check again that the jack is seated correctly.
8. Continue pumping the handle until the vehicle has been lifted to the desired height.
Caution: Observe the vehicle carefully during the lifting operation. The jack should move in the direction of the vehicle during lifting. Should this not be the case, there is a strong possibility that the vehicle will slide off the jack.
9. Put the handle out of the pumping arm. (Risk of accident!)
10. Secure the load with suitable jack stands before commencing work on or under the vehicle.
Caution: Working on or under the vehicle without first appropriately securing the raised load is prohibited! (Risk of accident!)
11. After you have finished working on the vehicle, open the drain valve by carefully twisting the jack handle in small increments in a counterclockwise direction until the vehicle begins to move downwards.
12. Once the vehicle is firmly on the ground, the drain valve can be opened again (approx, one half turn) in order to return the lifting arm all the way to the bottom in the starting position.
13. Before lifting the load, check that the drain valve is properly closed.
14. All moving parts must be lubricated in accordance with the operators' manual and maintained on a regular basis.

Storage & care:

15. When the vehicle jack is not in use, the lifting arm should be in the lowest position and the handle in an upright position to protect the precision mechanics from damage. The vehicle jack must be stored in a horizontal position and in a dry location. Ensure the jack remains in its original condition. Do not undertake any modifications to the device.
16. Use only SAE10 (SAE: Society of Automotive Engineers) grade, special-purpose hydraulic oil for the pump. Dispose of all used and spilled oil appropriately.
17. Do not use a high pressure cleaner to clean the jack. All external moving parts, e.g. the foot roller bearings, fastening bolts of the lifting arm, fastening bolts of the lifting arm cylinder and fastening bolts of the pumping arm must be well lubricated regularly every 3 months.
IMPORTANT: Never lubricate or grease the rods of the pump and lifting cylinder.
18. All maintenance and repair work must be performed by a suitably qualified personnel in accordance with the manufacturer's instructions.
19. **Caution:** Do not use the jack if there are any missing, loose or broken parts!



NOTE: The instructions below must not be carried out while the vehicle jack is In use.

NOTE: The vehicle jack is equipped with a safety valve (15). It has been configured to allow the vehicle jack to lift loads up to 2 tonnes. The safety valve must not be modified or adjusted in any way!

Troubleshooting

Problem	Possible cause	Action
The jack does not reach its full height.	Low level of oil in the jack.	Check the oil level.
	Air in the hydraulic system.	Bleed in accordance with the instructions.
The load lowers down.	The relief valve does not close properly.	Contact an authorised service centre.
	The oil is contaminated.	
	The pump valves are leaking	
	The piston is jammed.	
	Air in the hydraulic system.	Bleed in accordance with the instructions.
The lifting arm does not lower.	The piston is jammed.	Contact an authorised service centre.
	Worn parts.	
	Internal damage to the jack.	
	The return spring has broken, or come loose.	
	The lift linkage is damaged or jammed.	
	Air in the hydraulic system.	Bleed in accordance with the instructions.
Imprecise movement when lifting.	Air in the hydraulic system.	Bleed in accordance with the instructions.

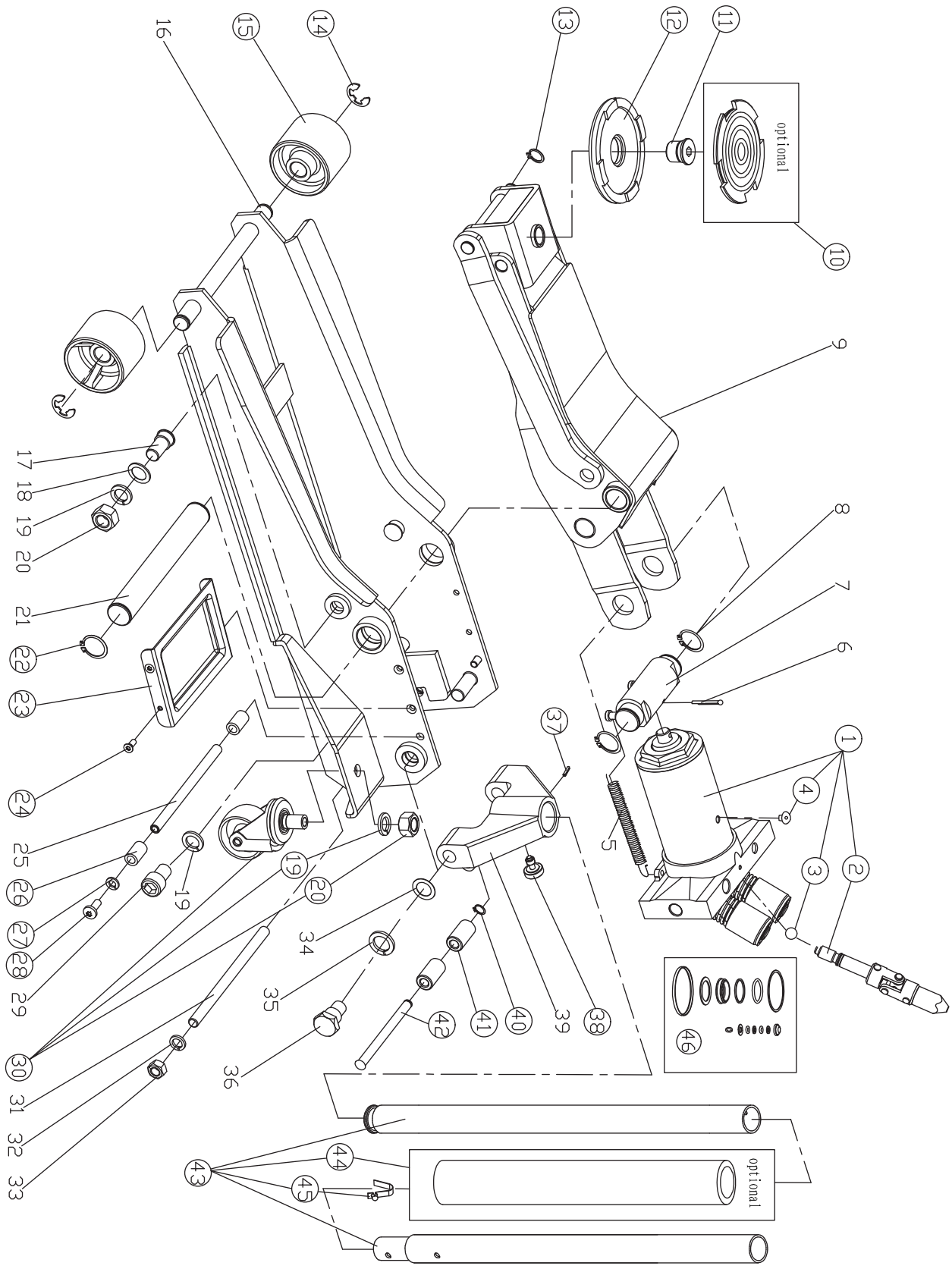

REF#	PART #	DESCRIPTION	QTY
1	T83508.3	Power unit assembly	1
2	T83508.3.1(asm)	Universal joint assembly	1
3	GB308-6	Steel ball bearing Ø6mm	1
4	TF1201C-29	Oil plug	1
5		Return spring	2
6		Cotter pin Ø4x40mm	1
7		Coupling connector	1
8		C-clip Ø30mm	2
9		Lifting arm assembly	1
10	T84007-3	Saddle pad (optional)	1
11	T83508-10	Pin for saddle	1
12	T84007-1	Saddle	1
13	GB894.1-18	C-clip Ø18mm	1
14	GB896-15	Side-mount external retaining ring Ø15mm	2
15	T84004-3	Front wheel	2
16		Frame assembly	1
17		Connecting rod pintle	2
18		Washer M16	2
19	GB859-16	Spring washer M16	6
20	GB6170-M16	Nut M16	4
21		Supporting shaft	1
22	GB894.1-28	C-clip Ø28mm	2
23	T830008E-2	Cover plate	1
24	GB70.3-M6X16	Flat-head socket cap screw M6X16mm	4
25		Handle socket shaft	1
26	T84004-7	Rubber sleeve	2
27	GB859-8	Spring washer M8	2
28	GB823-M8X16	Cross recessed countersunk head screw M8X16mm	2
29		Socket head cap screw M16X25mm	2
30	T83508.6(asm)	Rear caster assembly	2
31		Back shaft	1
32		Spring washer M12	2
33		Nut M12	2
34		Washer M18	2
35		Spring washer M18	2
36		Shoulder bolt M18x65mm	2
37	GB879-3X14	Spring pin Ø3X14mm	1
38	T83508.2-2	Handle socket screw M10X23.5mm	1
39		Handle socket	1
40	GB894.1-10	C-clip Ø10mm	1
41	T83508.2-3	Contact roller	2
42	T83508.2-4	Pin for roller	1
43	T83508.5	Handle assembly	1
44	T83508-9	Flexible protective pipe (optional)	1
45	T83508.5-4	Handle lock pin	1
46	T83508.MF	Seal kit	1

WARRANTY INFORMATION:

Please refer to our website for detailed warranty conditions and coverage.

For the most up-to-date and comprehensive warranty information, visit www.tmgindustrial.com