

11,000-LB CHAIN HOIST

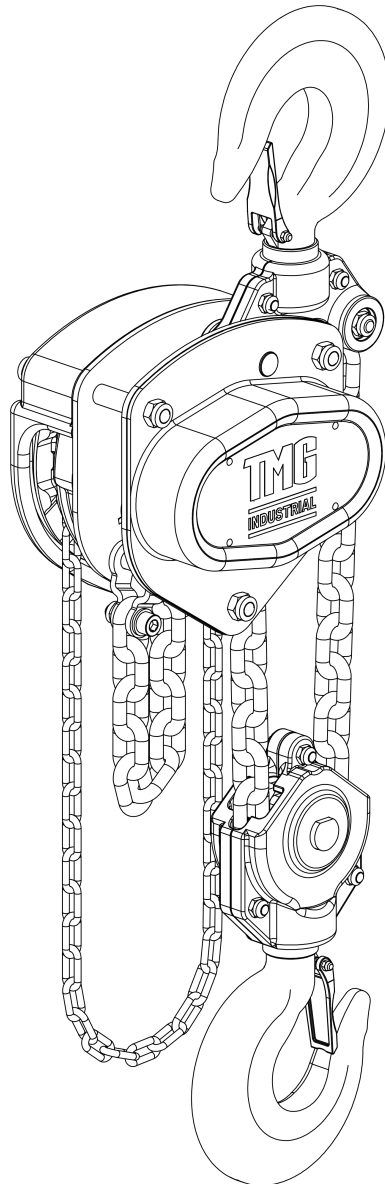

⚠ WARNING

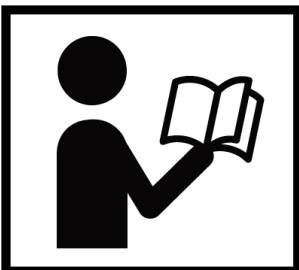

- Please read and understand the product manual completely before assembly
- Check against the parts list to make sure all parts are received
- Wear proper safety goggles or other protective gears while in assembly
- Do not return the product to dealer. They are not equipped to handle your requests.

Missing parts or questions on assembly?

Please call: 1-877-761-2819 or email: cs@tmgindustrial.com

TABLE OF CONTENTS

IMPORTANT INFORMATION AND WARNINGS.....	3
IMPORTANT SAFETY INSTRUCTIONS.....	3
WARNINGS AND PRECAUTIONS.....	4
SAFETY LABELING.....	5
PRODUCTS SPECIFICATIONS.....	6
PRE INSTALLATION INSTRUCTIONS.....	7
OPERATION INSTRUCTIONS.....	8
INSPECTION.....	8
MAINTENANCE.....	10
TROUBLESHOOTING.....	12
PARTS LIST AND EXPLOSION VIEW.....	13

Conventions used in this manual



WARNING

This indicates a hazardous situation, which, if not avoided, could result in death or serious injury.



CAUTION

This indicates a hazardous situation, which, if not avoided, could result in minor or moderate injury.



NOTICE

This information is important in proper using of your machine. Failure to follow this instruction could result in damage to your machine or property.

Additional Information and Potential Changes

We reserve the right to discontinue, change, and improve its products at any time without notice or obligation to the purchaser. The descriptions and specifications contained in this manual were in effect at printing. Equipment described within this manual may be optional. Some illustrations may not be applicable to your machine.

IMPORTANT INFORMATION AND WARNING



WARNING

- This product should not be installed, operated, or maintained by any person who has not read all the contents of these instructions. Failure to read and comply with these instructions, warnings, or limitations noted might result in bodily injury, death, or property damage.
- Contact the distributor for further explanation if information is not fully understood.
- It is the responsibility of the owner/user to install, test, maintain, and operate these products in accordance with OSHA regulations, other federal, state, and local regulations, and ANSI standards including:
 - ANSI/ASME B30.16- Manually Operated Chain Hoists
 - Other applicable volumes within ANSI/ASME B30
- Only trained and qualified personnel shall operate and maintain this equipment.

IMPORTANT SAFETY INSTRUCTIONS

- Read, understand and follow the safety information contained in these instructions prior to using this tool. Keep these instructions for further reference.
- Always operate, inspect and maintain this hoist in accordance with American National Standards Institute Safety Code ASME B30.16 and any other applicable safety codes and regulations.
- Hoists are designed to provide a 4 to 1 safety factor. Supporting structures and load-attaching devices used in conjunction with this hoist must provide an adequate safety factor to handle the rated load, plus the weight of the hoist and attached equipment. This is the customer's responsibility.
- Rigging: it is the responsibility of the operator to exercise caution and be familiar with proper rigging techniques. Refer to ASME B30.9 for rigging information.
- Do not exceed rated capacity. Hooks are designed to bend or stretch when overloading is detected.
- Do not use this hoist for lifting, supporting, or transporting people or lifting or supporting loads over people.
- During operation, always ensure a firm footing. Operate the hoist from a location that will be clear of the load at all times. People must stay clear of load at all times.
- Before lifting a load, confirm that the chain hoist is in good condition and functioning properly. Inspect the chain hoist regularly. Never use a chain hoist when malfunction, unusual performance, damage, or extensive wear are found.
- Always keep the load chain well lubricated and protect it from weld spatter and other damaging contaminants. Never allow the load chain or hooks be used as a ground for welding and never touch them with live welding electrodes. Never use the hoist with twisted, kinked, damaged or worn load chains. Never attempt to lengthen the load chain.
- Never use a chain hoist as a sling. Always use proper slings and attachments in the correct manner and confirm that they are seated properly in the hook, also confirm that the safety latch assembly has closed completely and not supporting any part of the load.
- Slacked load chain must be taken up carefully. While checking the balance of the load, lift and lower the load about 4" to test the brake system before lifting further. Loads must be lifted slowly.
- Never divert your attention when operating the chain hoist and never leave a suspended load unattended.
- Do not allow a load to drop, such as over the edge of a platform, while connected to a chain hoist. The sudden drop, even of a small distance, can cause a severe momentary overload, seriously damaging the chain hoist and possibly resulting in the loss of the load. This can occur at loads rated well below the rated capacity.
- Never adjust or repair a chain hoist unless you are qualified to perform hoist maintenance.
- Never modify the chain hoist. Approval from TMG is required for all nonstandard maintenance.
- Use only genuine TMG INDUSTRIAL parts when repairing the chain hoist.
- Never remove or obscure the nameplate on the chain hoist.
- Hoists from TMG INDUSTRIAL are rated for use between -40 to +60 °C, Humidity 100% or below. These are not underwater devices.

WARNINGS AND PRECAUTIONS

The following warnings and operating practices are intended to avoid unsafe hoisting practices which might lead to personal injury or property damage.

DO	DO NOT
<ol style="list-style-type: none"> 1. DO read the operating and maintenance instructions 2. DO be familiar with hoist operating controls, procedures, and warnings. 3. DO make sure that the unit is securely attached to a suitable support before applying load. 4. DO maintain firm footing or be secured when operating unit. 5. DO make sure that load slings or other approved sling attachments are properly sized and seated in the hook saddle. 6. DO make sure the hook safety latches are closed and not supporting any part of the load. 7. DO make sure load is free to move and will clear all obstructions. 8. DO take up slack carefully, check load balance, move the load a few inches, and check load holding action before continuing. 9. DO make sure all persons stay clear of the supported load. 10. DO avoid swinging of load or load hook. 11. DO protect load chain from weld spatter or other damaging contaminants. 12. DO promptly report any malfunction, unusual performance, or damage of the unit. 13. DO inspect unit regularly, replace damaged or worn parts, and keep appropriate records of maintenance. 14. DO use the recommended TMG INDUSTRIAL parts when repairing unit. 15. DO apply lubricant to load chain as recommended by TMG INDUSTRIAL 	<ol style="list-style-type: none"> 1. DO NOT lift or pull more than rated load. 2. DO NOT use the hoist load limiting device to measure the load weight. 3. DO NOT use damaged unit or unit that is not working correctly. 4. DO NOT apply a load unless chain is properly seated in chain wheel(s) or sprocket(s). 5. DO NOT use with twisted, kinked, damaged or worn chain. 6. DO NOT apply a load if any binding prevents equal loading on all load supporting chains. 7. DO NOT use load chain as a sling or wrap chain around a load. 8. DO NOT apply the load to the tip of the hook. 9. DO NOT operate except with hand power. 10. DO NOT operate unit when it is restricted from adjusting itself to form a straight line with the direction of loading. 11. DO NOT allow your attention to be diverted from operating the unit. 12. DO NOT allow more than one operator to pull on chain at same time. 13. DO NOT operate unit beyond limits of load chain travel. 14. DO NOT use hoist to lift, support or transport people. 15. DO NOT lift loads over people. 16. DO NOT leave a load supported by the unit unattended unless specific precautions have been taken. 17. DO NOT allow unit to be subjected to sharp contact with other units, structures, or objects through misuse. 18. DO NOT allow the chain or hook to be used as a ground for welding. 19. DO NOT allow the chain or hook to be touched by a live welding electrode. 20. DO NOT remove or obscure the warnings on the unit. 21. DO NOT adjust or repair a unit unless you are qualified to perform such maintenance. 22. DO NOT attempt to lengthen the load chain or repair damaged load chain. 23. DO NOT allow loads to drop suddenly while operating this lift. 24. DO NOT use hand chain to move loads. Move loads by pulling or pushing on the load itself or using a geared trolley. 25. DO NOT continue to pull on hand chain when the chain slips. This will continue to tighten the overload slip clutch and eventually bind the hoist. 26. DO NOT place loads on a hoist for raising or lowering a load. Hoists must only be used to lift loads.

SAFETY LABELING

The warning tags illustrated below are supplied with each hoist shipped from TMG INDUSTRIAL. If the tag is not attached to your hoist's no-load side of the load chain, order a tag from your dealer or TMG INDUSTRIAL and install it. Read and follow all warnings and guidelines attached to this hoist.



CAUTION

1. These general instructions deal with the normal installation, operation, and maintenance situations encountered with the equipment described herein. The instructions should not be interpreted to anticipate every possible contingency or to anticipate the final system, crane, or configuration that uses this equipment. For systems using the equipment covered by this manual, the supplier and owner of the system are responsible for the system's compliance with all applicable industry standards, and with all applicable federal, state, and local regulations/codes.
2. Record your hoist's model, purchasing date and Serial Number on the front cover of this manual for identification and future reference to avoid referring to the wrong manual for information or instructions on installation, operation, inspection, maintenance, or parts.
3. Use only TMG INDUSTRIAL authorized replacement parts in the service and maintenance of this hoist

NOTICE

1. It is the responsibility of the owner/user to install, inspect, test, maintain, and operate a hoist in accordance with ANSI/ASME B30.16, "Overhead Under-hung and Stationary Hoists" and OSHA Regulations.
2. If the hoist is installed as part of a total lifting system, such as an overhead crane or monorail, it is also the responsibility of the owner/user to comply with the applicable ANSI/ASME B30 volume that addresses that type of equipment.
3. It is the responsibility of the owner/user to have all personnel that will install, inspect, test, maintain, and operate a hoist, read the contents of this manual and applicable portions of ANSI/ASME B30.16, "Overhead Under-hung and Stationary Hoists" and OSHA Regulations.
4. If the hoist owner/user requires additional information, or if any information in the manual is not clear, contact TMG or the distributor of the hoist. Do not install, inspect, test, maintain, or operate this hoist unless this information is fully understood.
5. A regular schedule of inspection of the hoist in accordance with the requirements of ANSI/ASME B30.16 should be established, and records maintained.

PRODUCT SPECIFICATIONS

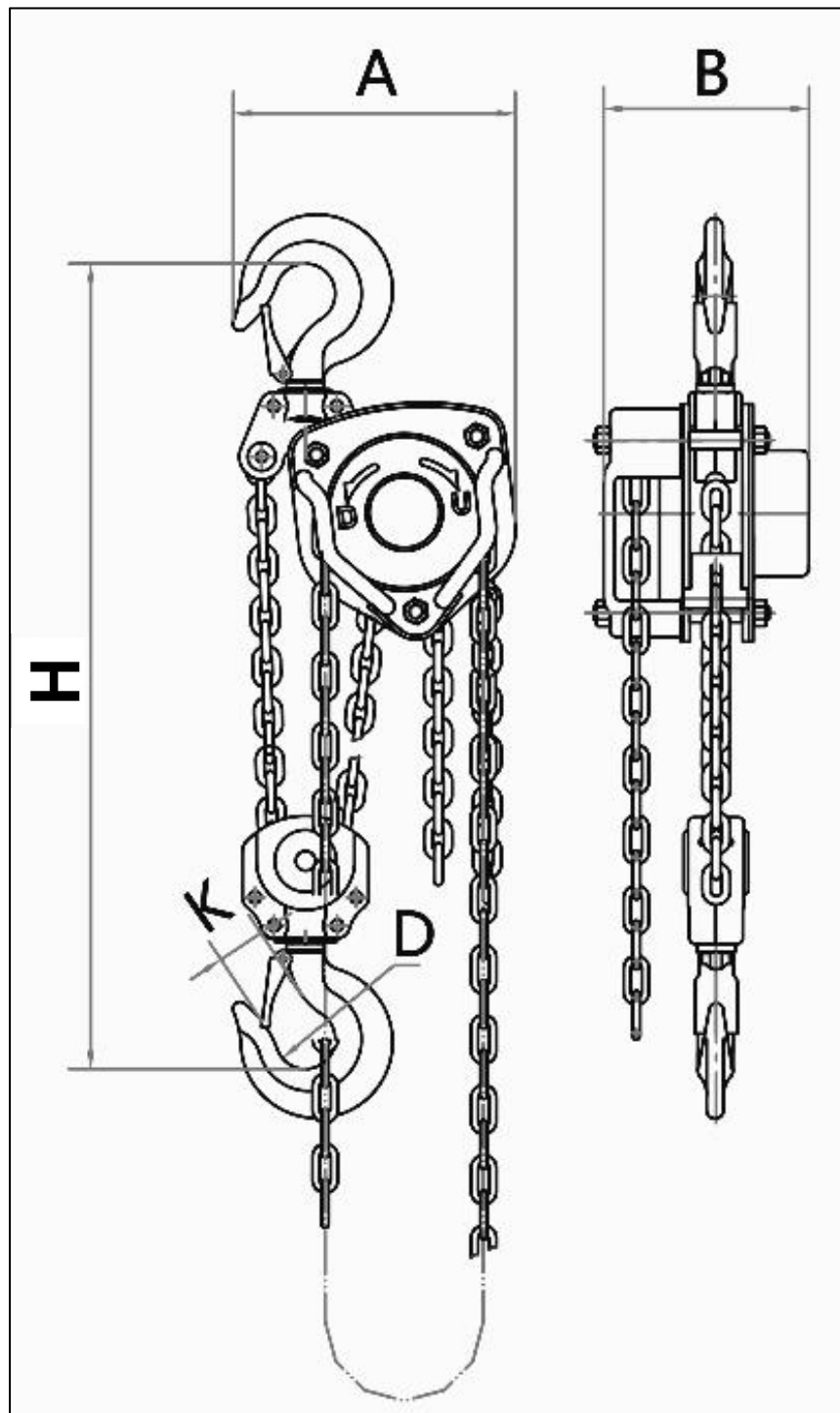

MODEL	CAPACITY (Ton)	STD LIFT (ft.)	CHAIN DIA. X FALLS	HOOK OPENING (mm)	DIMENSION (in.)			SHIP WEIGHT (lbs)
				K	A	B	H	
TMG-AHC5	5	20	Ø10 X2	46.0	11.34	7.52	24.33	87

PRE INSTALLATION INSTRUCTIONS

1. PREPARATION FOR USE

- Inspect carefully for any damage that may have occurred during shipping. Check for loose, missing, or damaged parts.
- Lubricate the load chain along the whole length with non-acid, non-corroding machine oil (See Figure 1).
- Examine the load chain to ensure that there are no twists (See Figure 2). 3 and 5 ton chain hoists have 2 falls of load chain, 10 ton has 4 falls. Twists can arise from the bottom hook being turned over through the load chains (See Figure 3). If a twist is found, reverse capsize the chain to correct.
- Confirm the brake is functioning properly by lifting a test load (10% of rated capacity) a few inches off the ground several times.
- Confirm that the supporting structure is strong enough to support the full rated capacity of the chain hoist with a generous factor of safety.

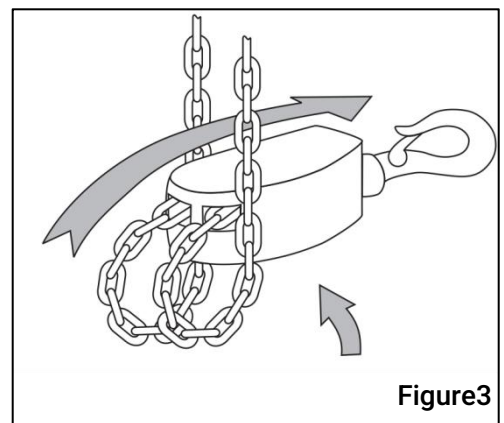
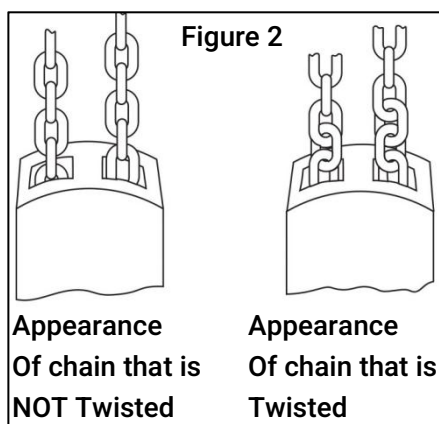
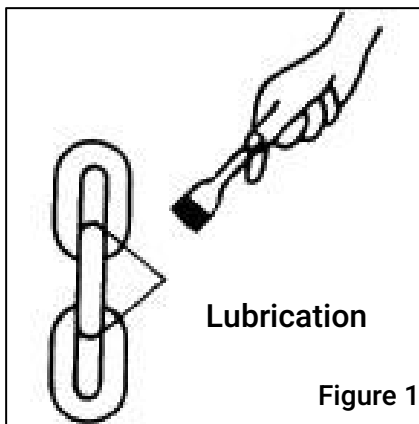

OPERATION INSTRUCTIONS

1. Attaching the Load

- If there are no twists in the chain, proceed on to attach the lower hook to the load
- Do not use the chain to wrap around the load.
- The load should be seated in the bowl of the hook and should not bear against the tip of the hook or latch.
- The hook latch should be tightly closed against the hook tip

Assure that the upper and lower hooks form a straight line and frame is able to swivel.



2. Hoisting (Raising the load)

- Pull the silver hand chain clockwise.

3. Lowering

- Pull the silver hand chain counter-clockwise.



Ensure the bottom hook block has NOT been flipped through the chain falls

Brake locking

- Chain hoists are used for vertical lifting of loads from a stationary position. Most lifting malfunctions are due to violating this principle.
- If transferring a load to a chain hoist, the chain hoist must be used to lift the load from the previous stationary environment. The load cannot be lowered onto a chain hoist. This automatically locks the braking mechanism.
- Never allow the load to drop suddenly or to swing when transferring loads.
- Never use a chain hoist as a towing device. Chain hoists are for lifting vertically only.
- Always use from a stationary lifting point. Never lift the hoist and load with another lifting device, such as a crane.

4. Operating Precautions

- Keep the load within the rated capacity marked on the chain hoist. An excess load may lead to an accident. The chain hoist is overloaded when the hand chain is no longer operable by a single operator, or the clasp on the load hook will no longer close.
- Before operating, lift and lower the load about 4" (10cm) and test the braking system. Ineffective braking may lead to an accident.
- Loads must be lifted as slowly as possible. Load swinging and abrupt shocks will impose excessive stress on the chain hoist and could lead to overloading or brake locking.
- Extreme temperatures will affect the durability of the chain hoist. In subzero temperatures, loads must be lifted and lowered very slowly and carefully.
- When hooking, the load must be applied squarely to the center of the hook and the hook must not come loose during operation.
- Mount the top hook for a fixed location. Ensure the fixed suspension point rests on the center of the hooks saddle and that the hook's safety latch is engaged.
- Do not side load the hoist. Chain hoists are for vertical lifting only.

5. Care After Use

- Always store your chain hoist in a no-load condition.
- Never leave or store the chain hoist with the brake system locked. Loosen the brake system by operating the chain hoist as if lowering a load.
- Always service and repair the chain hoist after use. Thoroughly clean the dust or if used in the rain, wipe off the dirt and moisture. Lubricate all moving parts of the hoist after use, especially the load chain, to prevent rust.
- Inspect the hooks and load chain for bends and any other type of defects. Also check to see if the hooks freely rotate. If any defect is found, replace the defective component before using the chain hoist again.
- Before returning hoist to service, follow instructions for hoists not in Regular Service in the INSPECTION Section 5.

INSPECTION PROCEDURES

1. INSPECTION PRECAUTIONS

- All new, altered or modified equipment should be inspected and tested by personnel trained in the safety, operation and maintenance of this equipment to ensure safe operation at rated specifications before placing equipment in service.
- Frequent and Periodic inspections should be performed on equipment in regular service.
- Frequent inspections are visual examinations performed by operators or service personnel and include observations made during routine equipment operation.
- Periodic inspections are thorough inspections conducted by personnel trained in the safety, operation and maintenance of this equipment.
- ASME B30.16 states inspection intervals depend up the nature of the critical components of the equipment and severity of usage.
- Deficiencies revealed through inspection or operation must be reported to designated personnel trained in safety, operation and maintenance of this equipment. Any corrective action must be completed and documented by written report before placing the equipment in service.

2. RECORDS AND REPORTS

- Inspection records should be maintained for all load bearing equipment requiring periodic inspection.
- Written reports should be made on the condition of the critical parts as a method of documenting periodic inspection. These reports should be dated, signed by the person who performed the inspection, and kept on file where they are readily available for review.

3. FREQUENT INSPECTION

- The Manual Chain Hoist should be inspected at the beginning of each shift. Visual inspections should also be conducted during regular service for any damage or evidence of malfunction which appears between regular inspections.
- »»**OPERATION:** Check for visual signs or abnormal noises which could indicate a potential problem. Do not operate a hoist unless the chain feeds through the hoist and hook block smoothly. If the chain binds, jumps or is excessively noisy, clean and lubricate the chain. Do not operate the hoist until all problems have been corrected. The bottom hook should stop moving when the hand chain stops moving.
- »»**HOOKS:** Check for wear and damage monthly. This includes: cracks, twists, latch engagement and latch operation (See Figure 4). Replace hooks that exceed the throat opening discard width. If the hook latch snaps past the tip of the hook, the hook has been overloaded and must be replaced. Check the hook support bearings for lubrication and damage. Check that hooks swivel easily and smoothly. Repair or lubricate as needed.
- »»**HOOK LATCHES:** Check operation of hook latches. Replace if broken or missing. Ensure they catch the tip of hook.
- »»**CHAIN:** Examine each link for bending, cracks in weld areas or shoulders, transverse nicks and gouges, weld spatter, corrosion pits, striation (minute parallel lines) and chain wear, including bearing surfaces between chain links (See Figure 5). Replace a chain that fails any of these inspections. Check lubrication and lubricate if necessary.
- »»**LOAD CHAIN REEVING:** Make sure welds on standing links are away from the load sheave. Reinstall chain if necessary (See Figure 6). Make sure chain is not capsized, twisted or kinked (See Figure 2 & 3). Adjust as required.

4. PERIODIC INSPECTION

- According to ASME B30.16, frequency of periodic inspection depends on the severity of usage.

NORMAL	HEAVY	SEVERE
Yearly	Semiannually	Quarterly

- Disassembly may be required for HEAVY or SEVERE usage. Any deficiencies must be corrected before hoist is returned to service. Keep records of periodic inspections to provide a basis for continuing evaluation. Inspect all items in 'Frequent Inspection'. Also inspect the following:
 - »»Chain for excessive wear or stretch.
 - »»Worn, cracked or distorted parts such as hook blocks, top hooks, chain guide, stripper, loose end pin, shafts, gears, hook collar and bearings.
 - »»Inspect for wear on the top of the pawl, teeth of the ratchet and pockets of the lift wheel and hand wheel. Loose or missing bolts, nuts, pins or rivets.
 - »»Inspect brake components for worn, glazed or contaminated friction discs and scoring of the hand wheel hub, ratchet, and friction hub.
 - »»Corroded, stretched or broken pawl spring.
 - »»Free movement of the pawl on the pawl stud.
 - »»Hook inspections using dye penetrant, magnetic particle or other suitable crack-detecting inspections should be performed at least once per year, if external conditions indicate possible unusual usage.

5. HOISTS NOT IN REGULAR USE

- A hoist that has been idle for a period of one month or more should be given a Frequent Inspection before use.
- A hoist that has been idle for a period longer than one year should be given a Periodic Inspection before use.
- Standby hoists should be inspected at least semiannually in accordance with the Frequent Inspection. In abnormal operating conditions this inspection should be completed at shorter intervals.

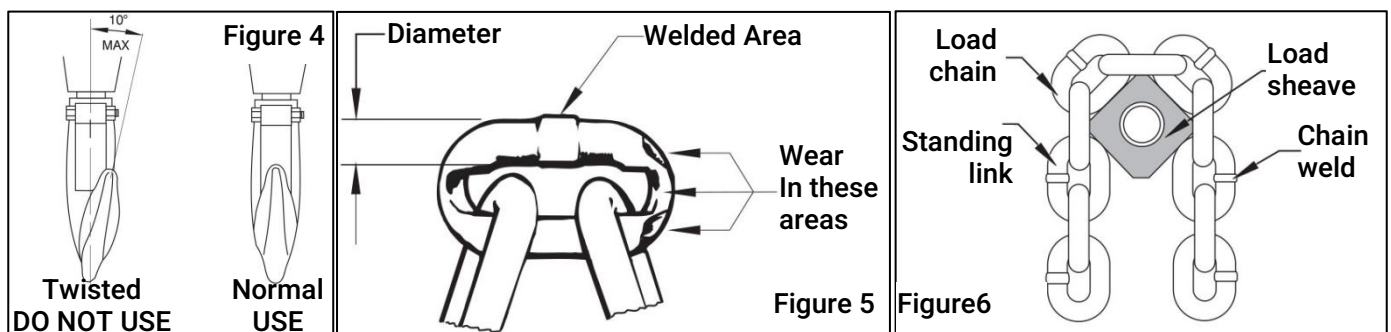

MAINTENANCE INSTRUCTION

- The chain hoist is designed and manufactured to withstand heavy duty material handling operations, but wear and damage are unavoidable after an extended use in less than ideal environments.
- Never leave the hoist in a damp environment or damp weather such as rain. Always store the hoist in a dry, well ventilated area.
- Proper lubrication will help lengthen the life of the chain hoist. Before storing, check to see if the hoist is well lubricated. Be especially sure that the moving parts, such as gears and bearings, are well lubricated.
- Load chain and hooks

Note: The load chains and hooks are precisely heat-treated.

Never weld or heat-treat the load chain.

1. Lubrication

Proper lubrication with machine oil is necessary to increase the life of the chain. Lubrication should be done based on usage and on a regular basis. It may be necessary on a weekly basis for heavy use or monthly if used less often.

- Clean the chain with an acid free cleaning solution to remove debris.
- Apply oil to chain focusing on bearing surfaces such as interlink areas.
- Do not apply oil to braking surfaces.
- Gears and shafts run on roller bearings and do not require lubrication.

2. Brake & top hook inspection & replacement

Disassembly

- Remove the cover using a standard socket wrench.
- Remove the hand chain from the wheel.
- Use needle nose-pliers to straighten the cotter pin.
- Remove nut.
- Remove secondary cover (protects the brake).
- Remove brake
- To disassemble the top hook remove the pin and the hook comes off.

Assembly

- Chain should be well seated in the wheel.
- Put the hand wheel back on.
- Should hear a click, indicating the brake is set.
- Hand tighten the nut.
- Push the cotter pin back in.
- Use pliers to flare the ears so it stays in place.
- Reattach the hand chain; making sure the weld is out.
- Attach cover and tighten lock nuts.

3. Storage of Hoist

Store the hoist in a clean dry area.

Maintain proper lubrication of the hoist while it is being stored.

If the hoist is malfunctioning clearly mark it before placing it in storage.

4. Outdoor Hoist Usage

Store hoist indoors when not in use.

Frequently inspect the hoist for signs of corrosion due to environmental factors.

Load Chain

Load chains worn-out or elongated beyond the permissible dimensions must be replaced at once. To examine, clean the chain with an acid-free solvent and, using a caliper style gauge, measure the inside length of 5 links of chain under light tension. Replace the entire load chain immediately if even one link of the load chain is extensively worn-out, elongated or damaged.

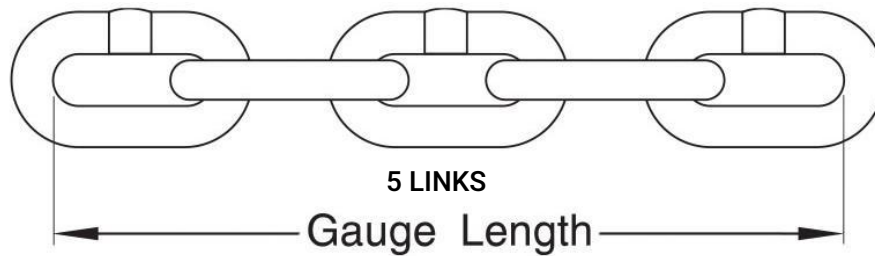

Load Chain Dimensions

CAPACITY(Tons)	DIAMETER(Ø mm)	STANDARD*(Ø mm)	LIMIT*(mm)
1/2	6	89.9	92.6
1	6	89.9	92.6
2	8	119.8	123.4
3	8	119.8	123.4
5	10	149.6	154.1

Hooks

TMG material handling hooks are designed to bend slightly when overloaded. If the hook opening is elongated beyond the permissible dimension (10% greater than standard), the hook is dangerously deformed and must be replaced at once. No deformation of the hook will arise when the chain hoist is used and maintained properly.

HOOK DIMENSIONS

CAPACITY (TONS)	STANDARD C SIZE (mm)	MAX C SIZE* (mm)
1/2	28.0	30.8
1	32.0	35.2
2	36.0	39.6
3	46.0	50.6
5	46.0	50.6

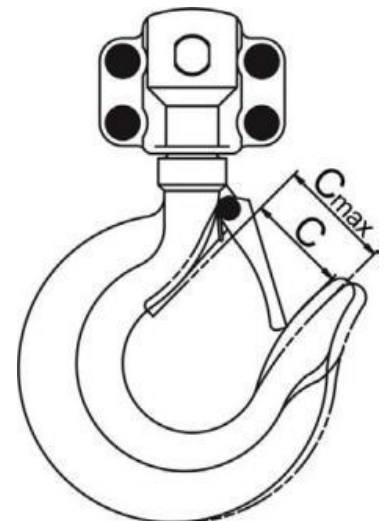

* Limit C size is 10% wider than the standard hook opening. The safety latch will not catch the hook tip once the hook is stretched beyond this point.

TROUBLE SHOOTING PROCEDURES

CONDITION	PROBABLE CAUSE	HOW TO REPAIR
Hoist will not lift load	1. Hoist is overloaded.	1. Reduce load to within hoist rated capacity.
Slip caused by ineffective braking	1. Worn-out friction discs. 2. Excessive oil on the braking surface. 1. Incorrect assembly of the braking system.	1. Replace with new friction discs. 2. Disassemble and clean. 3. Assemble correctly.
Load dropped while lowering	1. Damaged friction discs. 2. Foreign matters in the braking system.	1. Replace with new friction discs. 2. Disassemble and clean.
Load chain binds	1. Damaged load chain or internal parts 2. Load chain not installed properly (twisted, kinked or 'capsized').	1. Disassemble hoist, inspect and repair or replace damaged components. 2. Untwist load chain if possible, or uninstall load chain and re-install.
Hand chain binds	1. Damaged hand chain, hand chain wheel, or internal parts. 2. Hand chain not installed properly (twisted, kinked or 'capsized'). 3. Extremely long hand chain can swing and bind during use.	1. Disassemble hoist, inspect and repair or replace damaged components. 2. Untwist hand chain if possible, or uninstall load chain and re-install. 3. Pull load more slowly to avoid swinging hand chain. Pull chain the other way to unbind.
Noises during hoisting and lowering operation	1. Wear or deformation of the load chain and load sheave.	1. Replace with new parts.
Load hook latch does not work	1. Latch broken. 2. Load hook bent or twisted.	1. Replace hook latch. 2. Inspect load hook as described in (Maintenance instruction for hook) for signs of overloading
Load will not go down	1. The hoist was left under load for extended period. 2. Over tightened brake. 3. Shock loaded during operation. 4. Brake rusted tight.	1. For non-overload protection chain hoists, pulling harder on the chain may loosen brake. 2-4. If load cannot be moved, use another lifting device to remove the load from the affected hoist and replace brake components and perform hoist maintenance.

PARTS LIST AND EXPLOSIVE VIEW

Assembly Diagram

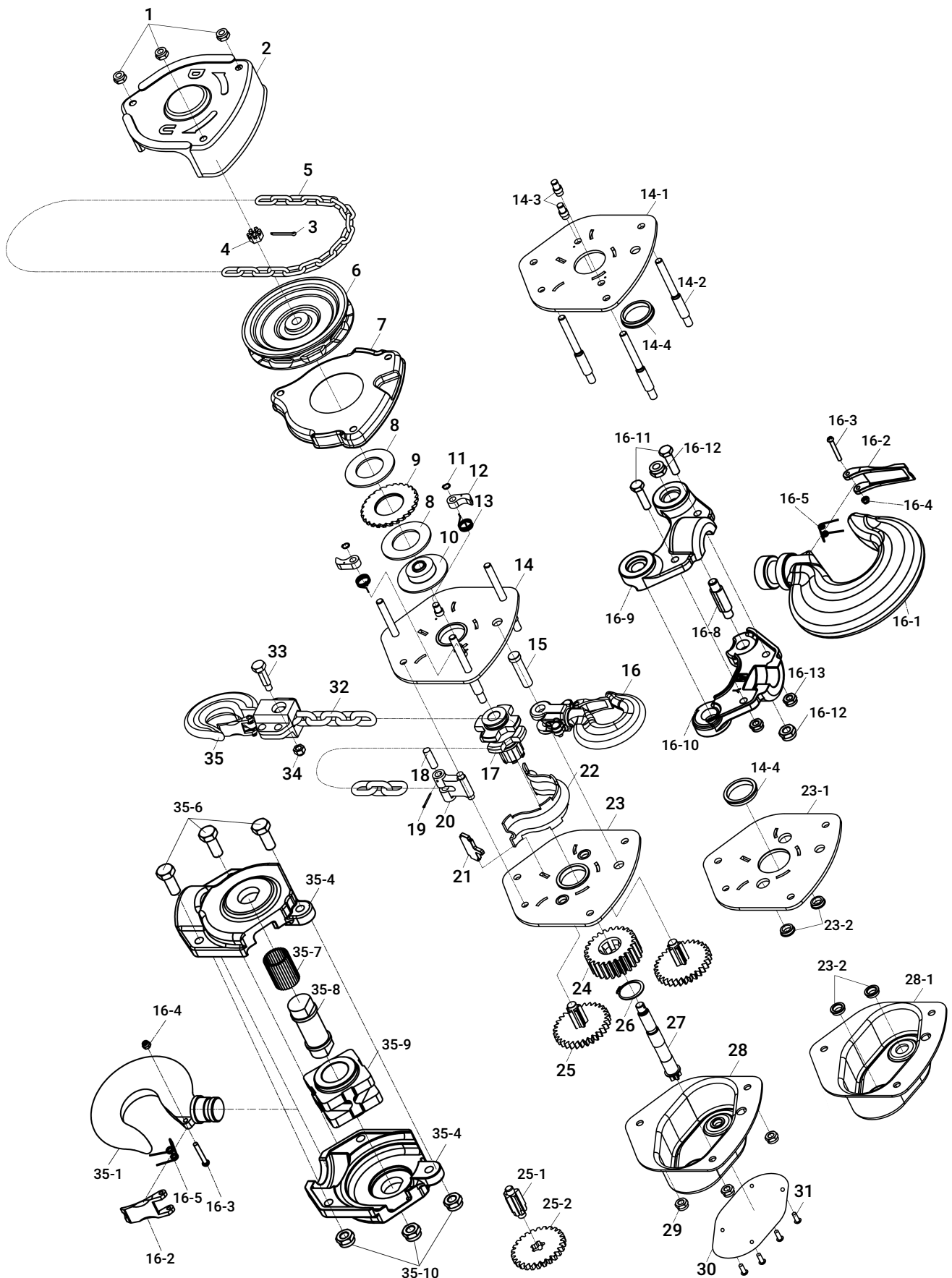

Parts List

PART NO.	DESCRIPTION	QTY	PART NO.	DESCRIPTION	QTY
1	Hex nut of hand wheel cover M8	3	17	Load chain	1
2	Hand wheel cover	1	18	Pin of end anchor	1
3	Split pin	1	19	Split pin	1
4	Hexagon slotted nut M12	1	20	End anchor	1
5	Hand chain	1	21	Stripper	1
6	Hand wheel	1	22	Load chain cover	1
7	Brake disc cover	1	23	Right side plate assembly	1
8	Friction plate	2	23-1	Right side plate	1
9	Ratchet gear	1	23-2	Steel ring	4
10	Brake seat	1	24	Splined gear	1
11	Snap ring	2	25	Disc gear assembly	2
12	Pawl	2	25-1	Gear 1st	2
13	Spring of pawl	2	25-2	Gear 2nd	2
14	Left side plate assembly	1	26	Snap ring	1
14-1	Left side plate	1	27	Pinion shaft	1
14-2	Support pin	3	28	Gear cover assembly	1
14-3	Pin of pawl	2	28-1	Gear cover	1
14-4	Needle bearing	2	29	Hex nut of gear cover	3
15	Pin of top hook	1	30	Name plate	1
16	Top hook assembly	1	31	Rivet of nameplate Ø2.5x4	4
16-1	Top hook	1	32	Load chain	1
16-2	Safety latch of top hook	2	33	Suspension pin of bottom hook	1
16-3	Pin of safety latch	2	34	Hex nut of suspension pin M10	1
16-4	Hex nut of safety latch M4	2	35	Bottom hook assembly	1
16-5	Spring of safety latch	2	35-1	Bottom hook	1
16-8	Hook pin of top hook	1	35-4	Bottom hook housing	2
16-9	Top hook housing A	1	35-6	Screw of bottom hook's M8x35	3
16-10	Top hook housing B	1	35-7	Needle bearing	1
16-11	Screw bolt of top hook's M8x35mm	2	35-8	Shaft of axle of bottom hook	1
16-12	Hex nut of top hook's housing A M8	2	35-9	Axle of bottom hook	1
16-13	Hex nut of top hook's housing B M8	2	35-10	Hex nut of bottom hook M4	3