

84" 3-POINT HITCH SNOW BLOWER

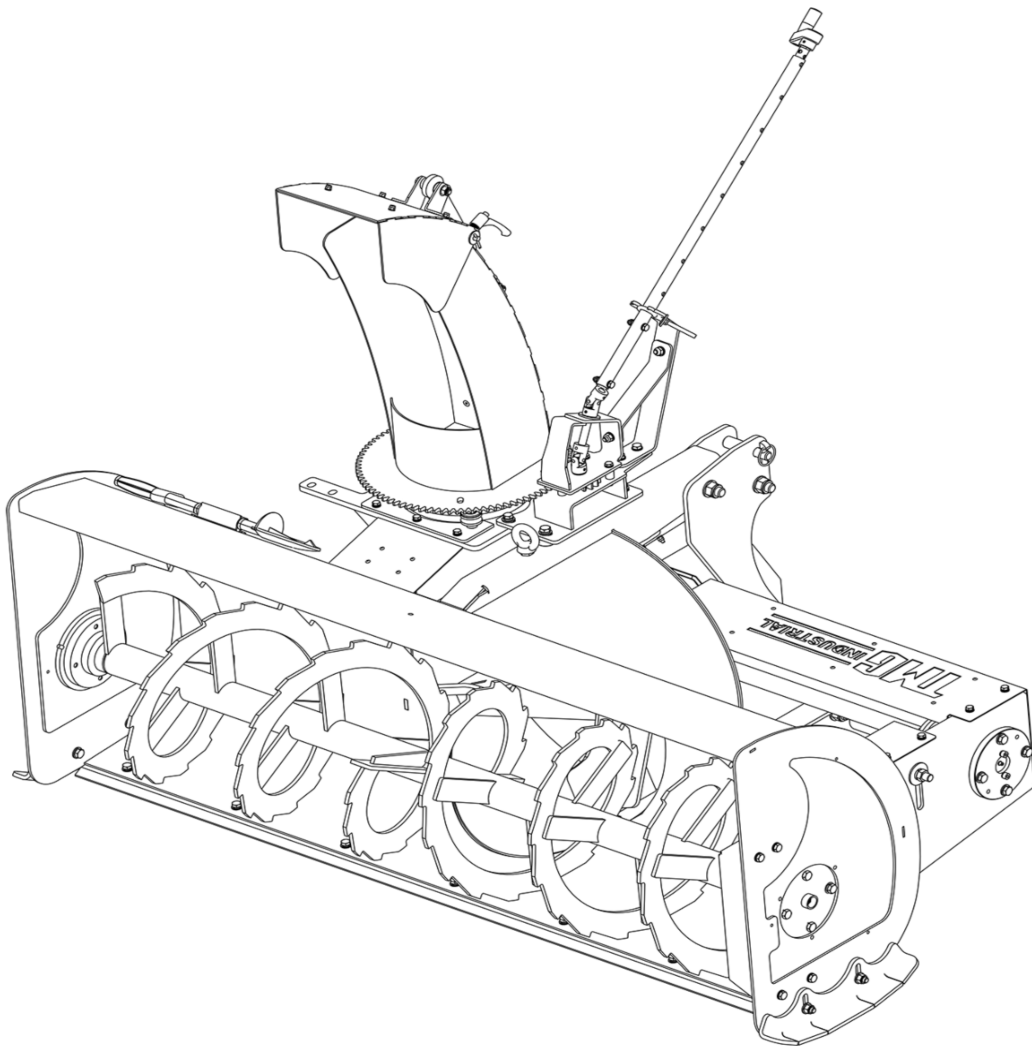

⚠ WARNING



- Please read and understand the product manual completely before assembly
- Check against the parts list to make sure all parts are received
- Wear proper safety goggles or other protective gears while in assembly
- Do not return the product to dealer. They are not equipped to handle your requests.

Missing parts or have questions on assembly?

Please call: 1-877-761-2819 or email: cs@tmgindustrial.com

TABLE OF CONTENTS

SAFETY INSTRUCTIONS	2
SAFETY RULE	3
PARTS DESCRIPTION AND FUNCTION	9
PRODUCTS SPECIFICATIONS	8
UNPACKING & ASSEMBLY	11
CONNECTING TRACTOR	16
LUBRICATION POINTS SUMMARY	18
OPERATING ESSENTIALS	21
OPERATING FINISH	22
MAINTENANCE SCHEDULE	23
TROUBLE SHOOTING	24
EXPLODED VIEW & PARTS LIST	25

SAFETY INSTRUCTIONS



Before operating the Snow Blower read the following safety instructions. Failure to comply with these warnings may result in serious injury or death.

SAFETY DECALS

▲ DANGER
AVOID INJURY OR DEATH
 • Stop engine before placing hand in discharge chute
 • Be aware that spinning fan blades can crush and cause dismemberment

▲ DANGER
AVOID INJURY OR DEATH
 Stay 10 feet away from the machine and its attachments when they are in use.

▲ DANGER
KEEP AWAY
 Keep hands, feet and face away from opening

FAILURE TO FOLLOW THESE INSTRUCTIONS MAY RESULT IN SERIOUS INJURY OR DEATH.

▲ DANGER
ROTATING AUGER KEEP AWAY!

• Keep hands, feet and clothing away from the rotating auger.
 • Lower the equipment, turn off the engine, remove the key, and set the brake before servicing.

FAILURE TO FOLLOW THESE INSTRUCTIONS MAY RESULT IN SERIOUS INJURY OR DEATH.

▲ DANGER
AVOID INJURY OR DEATH
 Do not operate with shields removed.

▲ DANGER
ROTATING DRIVELINE CONTACT CAN BE FATAL

KEEP AWAY!
 DO NOT OPERATE WITHOUT
 • Guards and shields in place.
 • Drivelines securely attached at both ends.
 • Driveline guards rotating freely.

MAX PTO 540 RPM

▲ WARNING
AVOID INJURY OR DEATH

• Read the Operators Manual before operating, servicing, or repairing equipment. Follow all safety rules and instructions.
 • Operate only from the tractor seat.
 • Before dismounting the tractor, lower equipment to the ground, stop the engine, remove the key, and set the brake.
 • Never allow children or untrained persons to operate equipment.
 • Never allow riders.
 • Keep all shields in place and in good condition.
 • Never direct discharge towards people, buildings, cars, etc.
 • Keep hands, feet, hair, and clothing away from moving parts.
 • Stop machine and wait for all movement to stop before unclogging or servicing the machine.
 • Ensure everyone is clear of the machine before starting and during operation.
 • Watch for hidden hazards on terrain during operation.
 • Never go under raised equipment.

FAILURE TO FOLLOW THESE INSTRUCTIONS MAY RESULT IN SERIOUS INJURY OR DEATH.

▲ DANGER
AVOID INJURY OR DEATH
 DO NOT OPERATE WITHOUT

Never direct discharge toward bystanders. Debris can be thrown great distances.

▲ DANGER
DO NOT start, operate or service machine until you read and understand the operator's manual.

Failure to do so could result in DEATH or SERIOUS INJURY, or damage to equipment.

▲ DANGER
AVOID INJURY OR DEATH

• Keep hands out of discharge chute while engine is running.
 • Shut off engine before unclogging discharge chute.

FAILURE TO FOLLOW THESE INSTRUCTIONS MAY RESULT IN SERIOUS INJURY OR DEATH.

▲ DANGER
FALLING OFF MAY RESULT IN BEING RUN OVER.

• This tractor must be equipped with ROPS or FOPS, LADD and seat belt. Keep ROPS system locked, unadjusted, unrestrained, or mechanical linkage failure.
 • Buckle up. Keep seat belt securely fastened.
 • Allow no riders.

RAISED IMPLEMENT CAN DROP AND CAUSE CRUSHING.

• Never get underneath a raised implement that could drop from the implement or tractor. This includes area to be under front differential, rear, hydraulic system failure, unadjusted movement of control levers, or mechanical linkage failure.
 • Service work done and engine stop, underneath the implement. Read the manual instructions.

FALLING OFF OR GOING UNDER A IMPLEMENT MAY RESULT IN SERIOUS INJURY OR DEATH.

▲ CAUTION
 THE FOLLOWING SAFETY PRECAUTIONS SHOULD BE THOROUGHLY UNDERSTOOD BEFORE ATTEMPTING TO BEGIN ASSEMBLING THIS MACHINE

1. Select an area for assembly that is clean and free of any debris which might cause persons working on the assembly to slip.
 2. Do not lift heavy parts or assemblies. Use cranes, jacks, hoists, lock trucks or other mechanical devices.
 3. Never use hands or feet to hold, hold, or support any assembly that is being lifted or lowered.
 4. Use proper lifting techniques. Lift with your legs, not your back. Never use your arms to support any load.
 5. Before working on equipment, from time to time regarding the proper assembly or operation, consult your dealer or the manufacturer.

⚠ DANGER

KEEP AWAY

Keep hands, feet and face away from opening.



FAILURE TO FOLLOW THESE INSTRUCTIONS MAY RESULT IN SERIOUS INJURY OR DEATH.

TMG-MACH-4117

⚠ CAUTION

THE FOLLOWING SAFETY PRECAUTIONS SHOULD BE THOROUGHLY UNDERSTOOD BEFORE ATTEMPTING TO BEGIN ASSEMBLING THIS MACHINE

- 1) Select an area for assembly that is clean and free of any debris which might cause persons working on the assembly to trip.
- 2) Do not lift heavy parts or assemblies. Use crane, jack, tackle, fork trucks or other mechanical devices.
- 3) Never put hands or any part of body under blocked up assemblies if at all possible.
- 4) After completing assembly, thoroughly inspect the machine to be sure that all nuts, bolts or any other fastened assemblies have been thoroughly tightened.
- 5) Before operating equipment, if you have any questions regarding the proper assembly or operation, contact your dealer or the manufacturer.

TMG-MACH-4040

MAX PTO 540

RPM

TMG-GNRL-0023

⚠ DANGER



DO NOT start, operate or service machine until you read and understand the operator's manual.

Failure to do so could result in DEATH or SERIOUS INJURY, or damage to equipment.

TMG-GNRL-0019

⚠ DANAGER



AVOID INJURY OR DEATH

- Stop engine before placing hand in discharge chute
- Be aware that spinning fan blades can crush and cause dismemberment

TMG-MACH-4120

⚠ DANGER

ROTATING AUGER KEEP AWAY!



- Keep hands, feet, and clothing away from the rotating auger.
- Lower the equipment, turn off the engine, remove the key, and set the brake before servicing.

FAILURE TO FOLLOW THESE INSTRUCTIONS MAY RESULT IN SERIOUS INJURY OR DEATH.

TMG-MACH-4119

⚠ DANGER

ROTATING DRIVELINE CONTACT CAN BE FATAL



KEEP AWAY!

DO NOT OPERATE WITHOUT

- Guards and shields in place.
- Drivelines securely attached at both ends.
- Driveline guards rotating freely.

TMG-MACH-4125

⚠ DANGER

- Keep hands out of discharge chute while engine is running.
- Shut off engine before unclogging discharge chute.



FAILURE TO FOLLOW THESE INSTRUCTIONS MAY RESULT IN SERIOUS INJURY OR DEATH.

TMG-MACH-4121

⚠ WARNING

AVOID INJURY OR DEATH

- Read the Operator's Manual before operating, servicing, or repairing equipment. Follow all safety rules and instructions.
- Operate only from the tractor seat.
- Before dismounting the tractor, lower equipment to the ground, stop the engine, remove the key, and set the brake.
- Never allow children or untrained persons to operate equipment.
- Never allow riders.
- Keep all shields in place and in good condition.
- Never direct discharge towards people, buildings, cars, etc.
- Keep hands, feet, hair, and clothing away from moving parts.
- Stop machine and wait for all movement to stop before unclogging or servicing the machine.
- Ensure everyone is clear of the machine before starting and during operation.
- Watch for hidden hazards on terrain during operation.
- Never go under raised equipment.

FAILURE TO FOLLOW THESE INSTRUCTIONS MAY RESULT IN SERIOUS INJURY OR DEATH.

TMG-MACH-4126

⚠ DANGER

FALLING OFF MAY RESULT IN BEING RUN OVER.

- The tractor must be equipped with ROPS (or ROPS CAB) and a seat belt. Keep foldable ROPS systems in the "LOCKED UP" position.
- Buckle up. Keep seat belt securely fastened.
- Allow no riders.



RAISED IMPLEMENT CAN DROP AND CAUSE CRUSHING.

- Never go underneath a raised implement that could drop from the equipment or tractor. This may occur due to 3-point hitch hydraulic leaks, hydraulic system failures, unexpected movement of control levers, or mechanical linkage failures.
- Service work does not require going underneath the implement. Read the manual instructions.

FALLING OFF OR GOING UNDERNEATH IMPLEMENT MAY RESULT IN SERIOUS INJURY OR DEATH.

TMG-MACH-4127

⚠ WARNING

AVOID INJURY OR DEATH

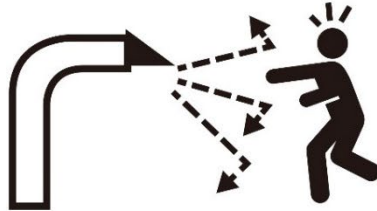

Never direct discharge toward bystanders. Debris can be thrown great distances.

TMG-MACH-4122

⚠ DANAGER



AVOID INJURY OR DEATH

Do not operate with shields removed.

TMG-MACH-4123

⚠ DANAGER



AVOID INJURY OR DEATH

Stay 10 feet away from the machine and its attachments when they are in use.

TMG-MACH-4118

SAFETY RULE

❖ WARNING

Careful operation is your best assurance against an accident. All operators, no matter how much experience they may have, should carefully read this manual and other related manuals before operating the power machine and this implement.



- Thoroughly read and understand the "Safety Label" section. Read all instructions noted on them.
- Do not operate the equipment while under the influence of drugs or alcohol, as they impair your ability to safely and properly operate the equipment.
- The operator should be familiar with all functions of the tractor and attached implement, and be able to handle emergencies quickly.
- Make sure all guards and shields appropriate for the operation are in place and secured before operating the implement.
- Keep all bystanders away from equipment and work area.
- Start tractor from the driver's seat with hydraulic controls in neutral.
- Operate tractor and controls from the driver's seat only.
- Never dismount from a moving tractor or leave tractor unattended with engine running.
- Do not allow anyone to stand between the implement and tractor while backing up to the implement.
- Keep hands, feet, and clothing away from power-driven parts.
- While transporting and operating equipment, watch out for objects overhead and along the sides such as fences, trees, buildings, wires, etc.
- Do not turn tractor so tight as to cause hitched implement to ride up on the tractor's rear wheel.
- Store implement in a safe and secure area where children normally do not play. When needed, secure implement against falling with support blocks.

❖ PREPARATION

- Keep a first aid kit and fire extinguisher handy.
- Keep the nozzle in contact with the rim of the fuel tank or container opening at all times, until refueling is complete. Do not use a nozzle lock open device.
- Wear protective clothing and equipment appropriate for the job such as safety shoes, safety glasses, hard hat, dust mask, and ear plugs
- Clothing should fit snug without fringes and pull strings to avoid entanglement with moving parts.
- Prolonged exposure to loud noise can cause hearing impairment or hearing loss. Wear suitable hearing protection such as earmuffs or earplugs.
- Operating a machine safely requires the operator's full attention. Avoid wearing headphones while operating Equipment

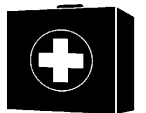

❖ SAFETY PRECAUTIONS FOR CHILDREN

Tragedy can occur if the operator is not alert to the presence of children, Children generally are attracted to implements and their work

- Never assume children will remain where you last saw them.
- Keep children out of the work area and under the watchful eye of a responsible adult.
- Be alert and shut the implement and tractor down if children enter the work area.
- Never carry children on the tractor or implement. There is not a safe place for them to ride. They may fall off and be run over or interfere with the control of the power machine.
- Never allow children to operate the power machine, even under adult supervision.
- Never allow children to play on the power machine or implement.
- Use extra caution when backing up. Before the tractor starts to move, look down and behind to make sure the area is clear.

❖ Wear Personal Protective Equipment (PPE)

- Wear protective clothing and equipment appropriate for the job such as safety shoes, safety glasses, hard hat, dust mask, and ear plugs.
- Clothing should fit snug without fringes and pull strings to avoid entanglement with moving parts.
- Prolonged exposure to loud noise can cause hearing impairment or hearing loss. Wear suitable hearing protection such as earmuffs or earplugs.
- Operating a machine safely requires the operator's full attention. Avoid wearing headphones while operating equipment.



❖ Handle Chemicals Properly

- Protective clothing should be worn.
- Handle all chemicals with care.
- Follow instructions on container label.
- Agricultural chemicals can be dangerous. Improper use can seriously injure persons, animals, plants, soil, and property.
- Inhaling smoke from any type of chemical fire can be a serious health hazard.
- Store or dispose of unused chemicals as specified by the chemical manufacturer.

✧ OPERATION

- Do not put hands or feet near, under or inside rotating parts.
- Exercise extreme caution when operating on or crossing gravel drives, walks or roads. Stay alert for hidden hazards or traffic. Do not carry passengers.
- Never tolerate bystanders in the working zone. Never use an accessory in the direction of bystanders, it might throw gravel or debris that can hurt people or damage property.
- Never operate the accessory at high transport speeds on slippery surfaces. Use care when backing up.
- Do not carry passengers.
- Disengage power to the accessory when it is transported or not in use.
- Never operate the accessory without good visibility or light.
- Keep the accessory away from heat sources or flames.
- Never handle the winch cable or hook while in tension.
- Use only accessories approved by the manufacturer of the snow blower (such as wheel chains, and the like).
- Never operate the snow blower without good visibility or light
- Keep all safety guards in place and in proper working order at all times.
- NEVER place fingers, hands, or body near the snow blower when it is running. Do not lean or reach over the snow blower when the machine is running.
- Keep all people (except the operator) a minimum of 25 feet from the snow blower during operation.
- Always aim the discharge chute away from people and animals.
- Do not leave the snow blower unattended when it is running. Turn off the engine before leaving the area.
- Do not use this piece of equipment while tired or under the influence of drugs, alcohol or medication.
- Parts, especially exhaust system components, get very hot during use. Stay clear of hot parts.
- Use extra caution when operating on gravel or other loose material.
- Exercise caution to avoid slipping or falling, especially when operating in reverse.
- Thoroughly inspect the area where the equipment is to be used. Remove all foreign objects, which could be tripped over or thrown by the auger/impeller.
- Always wear safety glasses or eye shields during operation and while performing an adjustment or repair to protect your eyes. Thrown objects which ricochet can cause serious injury to the eyes.
- Operate the equipment with appropriate foot ware, gloves and clothing. Avoid loose fitting clothing that can get caught in moving parts.
- The auger and drive controls must be depressed to operate. Do not override this safety feature. Both control levers must operate easily and automatically return to the disengaged position when released.
- Do not overload the snow blower by attempting to clear snow too quickly.
- Do not operate at high speed on icy or slippery surfaces.
- Always be sure of your footing especially when driving in reverse.

❖ PRACTICE SAFE MAINTENANCE

- Understand procedure before doing work. Refer to the Operator's Manual for additional information
- Work on a level surface in a clean dry area that is well-lit.
- Lower implement to the ground and follow all shutdown procedures before leaving the operator's seat to Perform maintenance.
- Do not work under any hydraulically supported equipment. It can settle, suddenly leak down, or be lowered accidentally. If it is necessary to work under the equipment, securely support it with stands or suitable blocking beforehand
- Use properly grounded electrical outlets and tools.
- Use correct tools and equipment for the job that are in good condition.
- Allow equipment to cool before working on it.
- Disconnect battery ground cable before servicing or adjusting electrical systems or before welding on implement.
- Inspect all parts. Make certain parts are in good condition & installed properly.
- Do not alter this implement in a way which will adversely affect its performance.
- Do not grease or oil implement while it is in operation.
- Remove buildup of grease, oil, or debris.
- Always make sure any material and waste products from the repair and maintenance of the implement are properly collected and disposed.
- Remove all tools and unused parts from equipment before operation.
- Do not weld or torch on galvanized metal as it will release toxic fumes.



❖ MTRANSPORT SAFETY

- Read this owner's manual carefully. Be thoroughly familiar with the controls and proper use of the vehicle and snow blower. Know how to stop the unit and disengage the controls quickly..
- Never allow children to operate snow blower nor the vehicle. Never allow adults to operate snow blower nor the vehicle without proper instructions..
- No one should operate the vehicle nor the snow blower while intoxicated or while taking medication that impairs the senses or reactions.
- Keep the area of operation clear of all persons, particularly small children and pets
- Comply with state and local laws governing safety and transporting of machinery on public roads.
- Check that all the lights, reflectors and other lighting requirements are installed and in good working condition.
- Do not exceed a safe travel speed. Slow down for rough terrain and cornering
- Do not drink and drive.
- Be a safe and courteous driver. Always yield to oncoming traffic in all situations, including narrow bridges, intersections, etc. Watch for traffic when operating near or crossing road- ways.
- Never allow riders on the machine.

❖ Use Seat Belt and ROPS

- Recommends the use of a CAB or roll-over-protective- structures (ROPS) and seat belt in almost all power machines.
- Combination of a CAB or ROPS and seat belt will reduce the risk of serious injury or death if the power machine should be upset.
- If ROPS is in the locked-up position, fasten seat belt snugly and securely to help protect against serious injury or death from falling and machine overturn

❖ Keep Riders Off Machinery

- Never carry riders on the tractor or implement.
- Riders obstruct operator's view and interfere with the control of the power machine.
- Riders can be struck by objects or thrown from the equipment.
- Never use the tractor or implement to lift or transport riders.

❖ Transport Safely

- Comply with federal, state, and local laws.
- Avoid contact with any overhead utility lines or electrically charged conductors.
- Engage park brake when stopped on an incline.
- Maximum transport speed for an implement is 20 mph (32 km/h). DO NOT EXCEED.
- Never travel at a speed which does not allow adequate control of steering and stopping. Some rough terrains require a slower speed.
- Sudden braking can cause a towed load to swerve and upset.
- Do not tow an implement that, when fully loaded, weights more than 1.5 times the weigh of towing vehicle.



PARTS DESCRIPTION AND FUNCTION

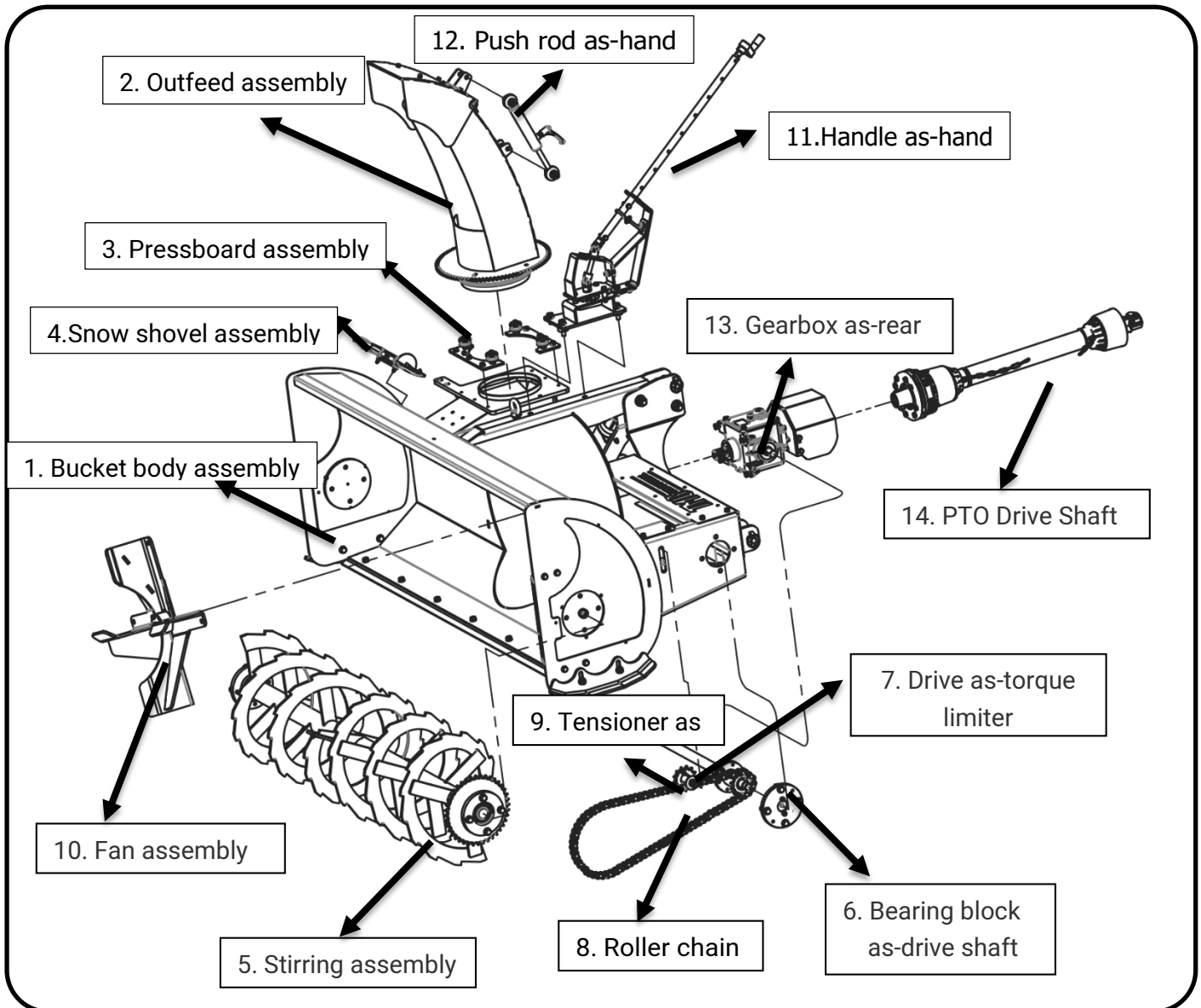

1. Bucket body assembly

Collect the snow raised by the augers

2. Outfeed assembly

Lift the snow out

3. Pressboard assembly

It is used to adjust and fix the snow outlet

4. Snow shovel assembly

Clean snow from snow chute or auger before and after use

5. Stirring assembly

Snow removal and ice breaking on roads

6. Bearing block as-drive shaft

To power the auger

7. Drive as-torque limiter

To power the auger

8. Roller chain

To power the auger

9. Tensioner as

To power the auger

10. Fan assembly

Blow up the snow

11. Handle as-hand

Control of snow outlet left and right steering

12. Push rod as-hand

For controlling the angle of the top of the snow outlet

13. Gearbox as-rear

It is used to connect the PTO to power the tractor

14. PTO Drive Shaft

It is used to connect tractors to provide

PRODUCTS SPECIFICATIONS

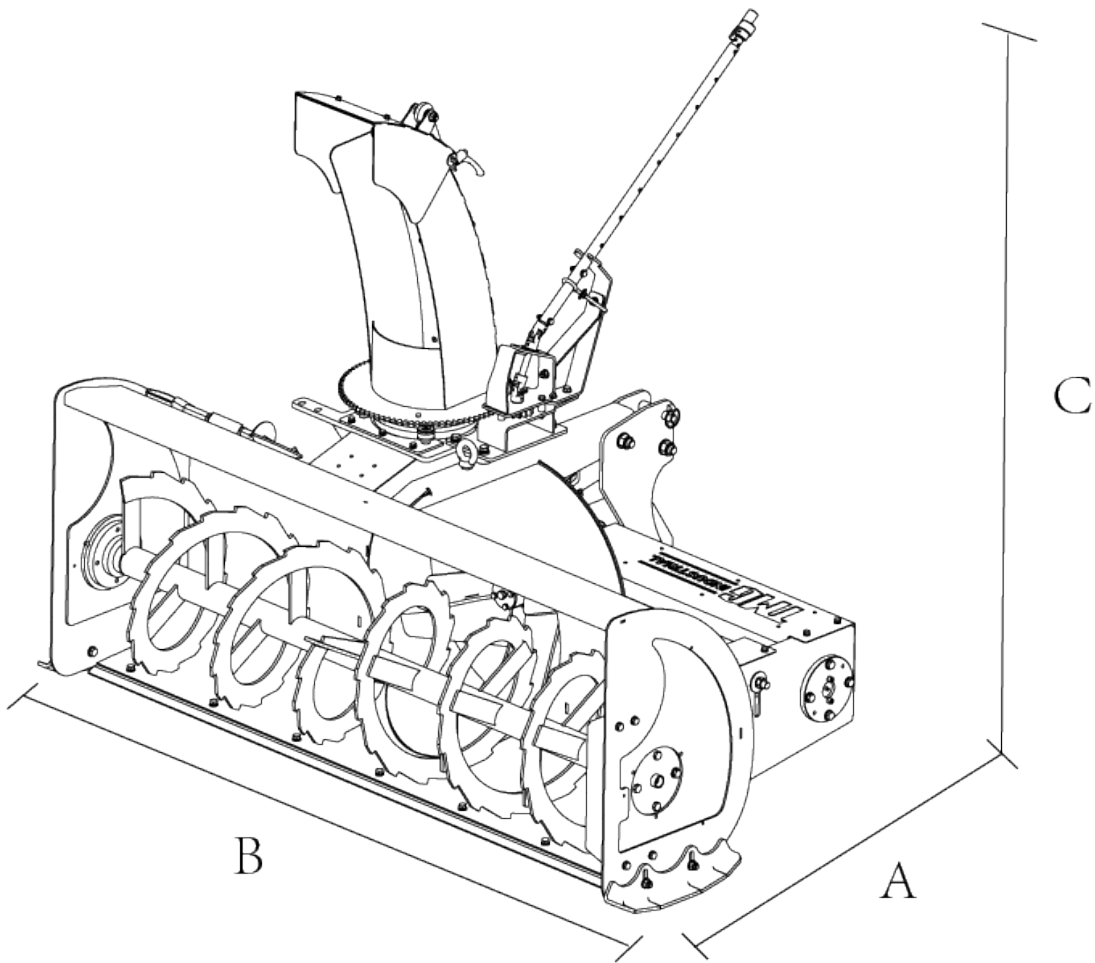

3-Point Tractor Snow Blower

SNOWBLOWER	TMG-TBS84
Shipping weight	987lbs(447.6kg)
Operating weight	841lbs(381kg)
DIMENSIONS	
Overall length	44.6 in (1133mm)
Overall width	86.6in (2200mm)
Overall height	63.5 in (1613mm)
Cutting width	82.7 in (2100 mm)
Cutting height	27.65 in(702mm)
Impeller diameter	24 in(610mm)
Impeller housing depth	7.87 in(200mm)
Auger diameter	17.5 in(445mm)
Auger height	11.55 in(293mm)
Auger clearance from ground	2.77 in(70mm)
DRIVE SYSTEM	
Primary drive	PTO
PTO input	540 RPM
Auger speed	180 RPM

Gearbox oil capacity	1 Qt SAE 90
PTO horsepower requirement	25- 90 HP
Tractor hitch	CAT1 & CAT2
Number of blades on impeller	4
Chute rotation	Manual
Chute rotation degrees	360 degrees
Discharge chute diameter	8.66 in (220mm)
Adjustable chute deflector	Yes
Adjustable skid shoes	Yes
Replaceable cutting edge	Yes
Hitch system	Quick hitch system (ASABE)

UNPACKING & ASSEMBLY

After unpacking, check the following components

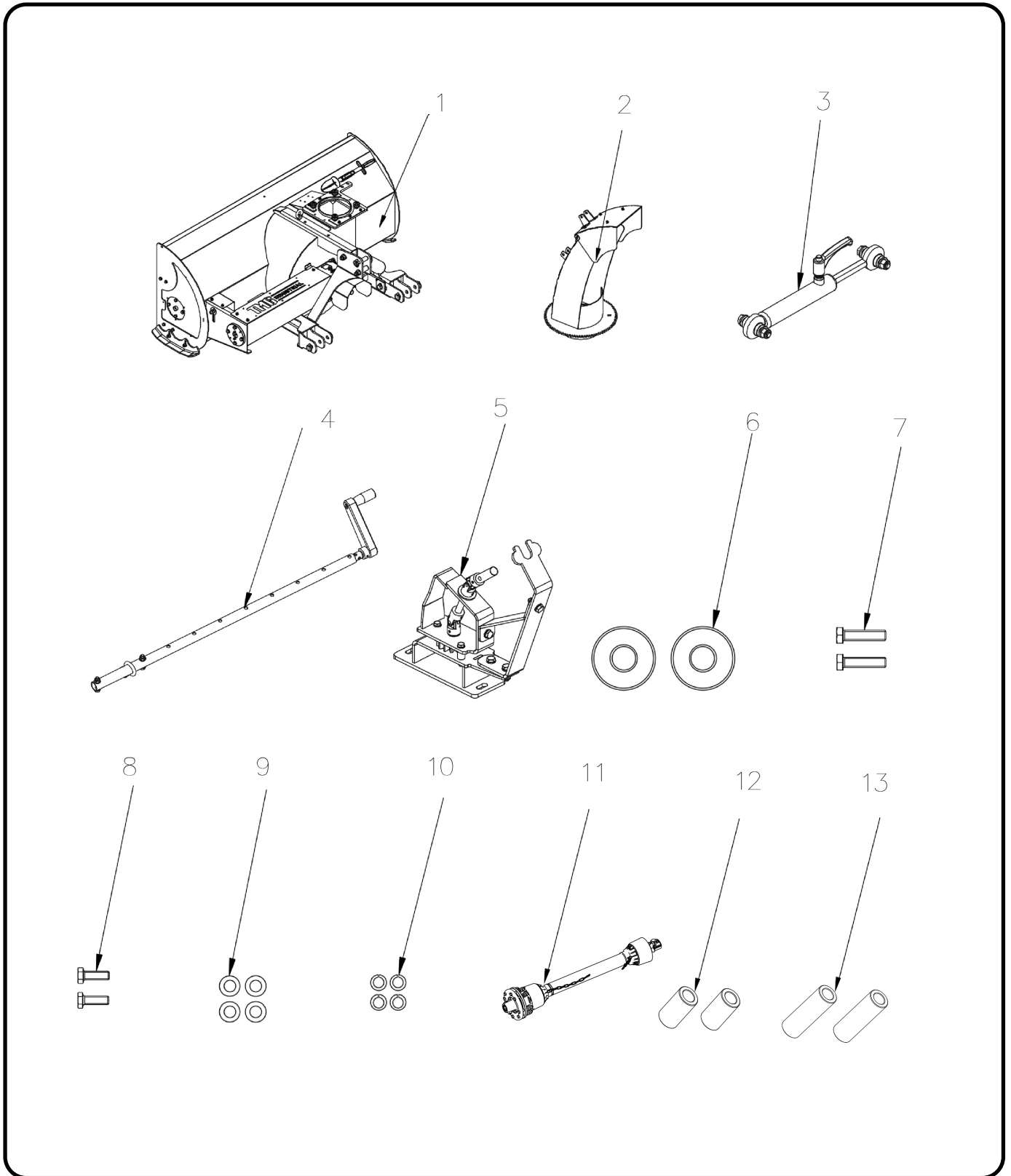

* All numbers are not part numbers in the drawings. For correct part **numbers, see explosive diagra**

NO.	DESCRIPTION	QTY	NO.	DESCRIPTION	QTY
1	Bucket body assembly	1	7	Full thread bolt	2
2	Outfeed assembly	1	8	Full thread bolt	2
3	Push rod as-hand	1	9	Plain washer	4
4	Handle as-hand(rocker)	1	10	Spring washer	4
5	Handle as-hand(base)	1	11	PTO Drive Shaft (with Clutch)	1
6	Pad block	2	12	Lower hanging pin sleeves	2
13	Under hanging fast sleeves	2			

TOOLS USED FOR INSTALLATION				
NO	DESCRIPTION	SPECIFICATION	CONDITIONS OF USE	QTY
1	open end wrench	13/19	M8, M12 bolt fastening	2
2	wind gun	1280t	Match the corresponding sleeve instead of the wrench to tighten the bolt	1
3	hammer			1
4	torque wrench	10-220N·m	Measuring torque	1

1. Install the hand push rod (For controlling the angle of the top of the snow outlet)

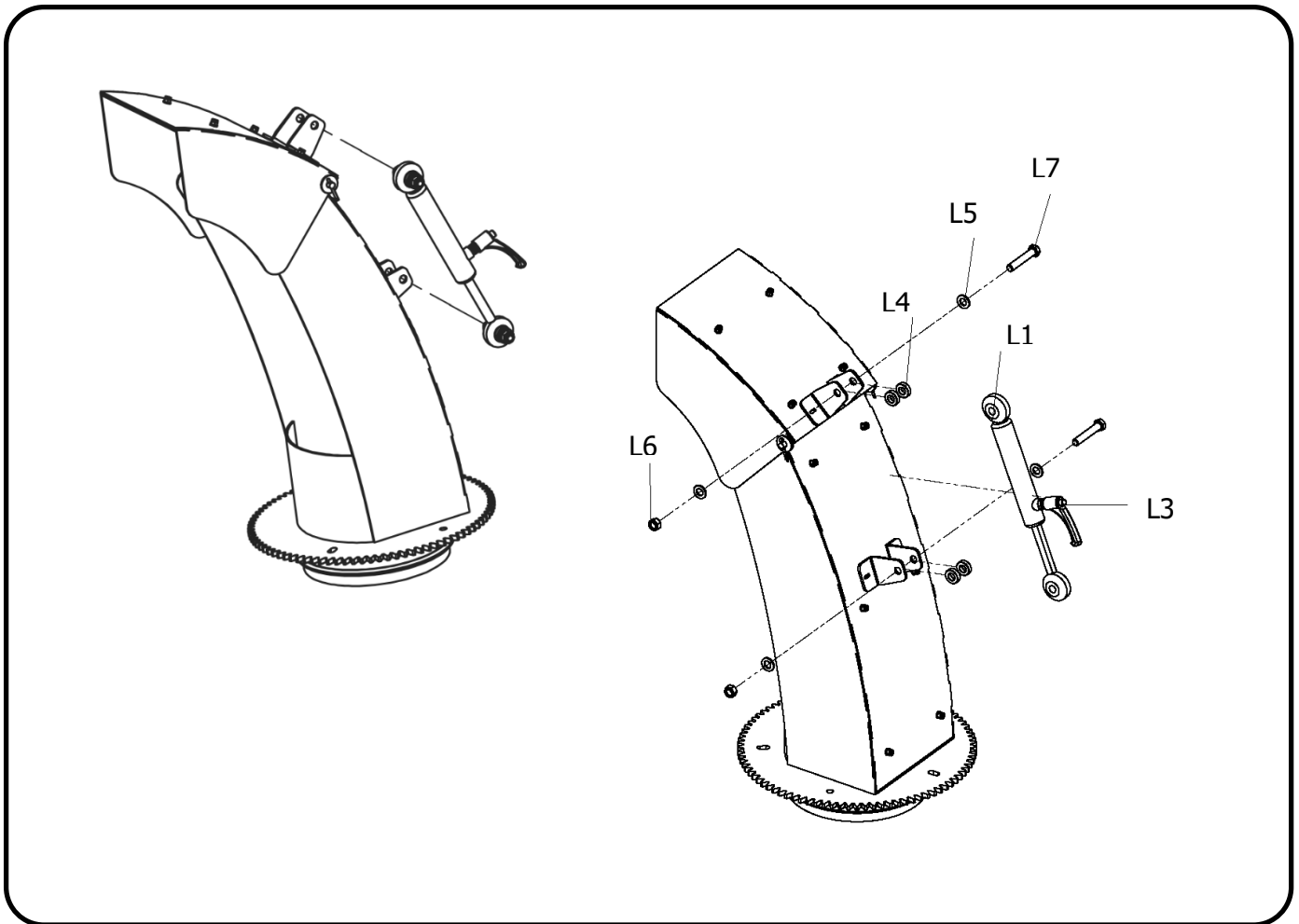

Installation steps:

1. Install the hand push rod on the snow outlet, install the handle (L3) on the manual cylinder welding, and then secure the Spacer sleeves (L4), Plain washers (L5), Full-thread hexagon bolts M12*70 (L7) and Locknuts M12(L6) on Manual push rod welding parts (L2).
2. Importance: All bolts are locked in place without shaking.



WARNING: Once the assembly bolts are not fastened in place, there will be abnormal noises when the machine is working.

PART NO.	DESCRIPTION	QTY	PART NO.	DESCRIPTION	QTY
L1	Push rod welding parts	1	L5	Plain washers $\varphi 12$	4
L3	Handle M10*1.25*25	1	L6	Locknuts M12	2
L4	Spacer sleeves	4	L7	Full-thread hexagon bolts M12*70	2

2. Install the Plate as-stop

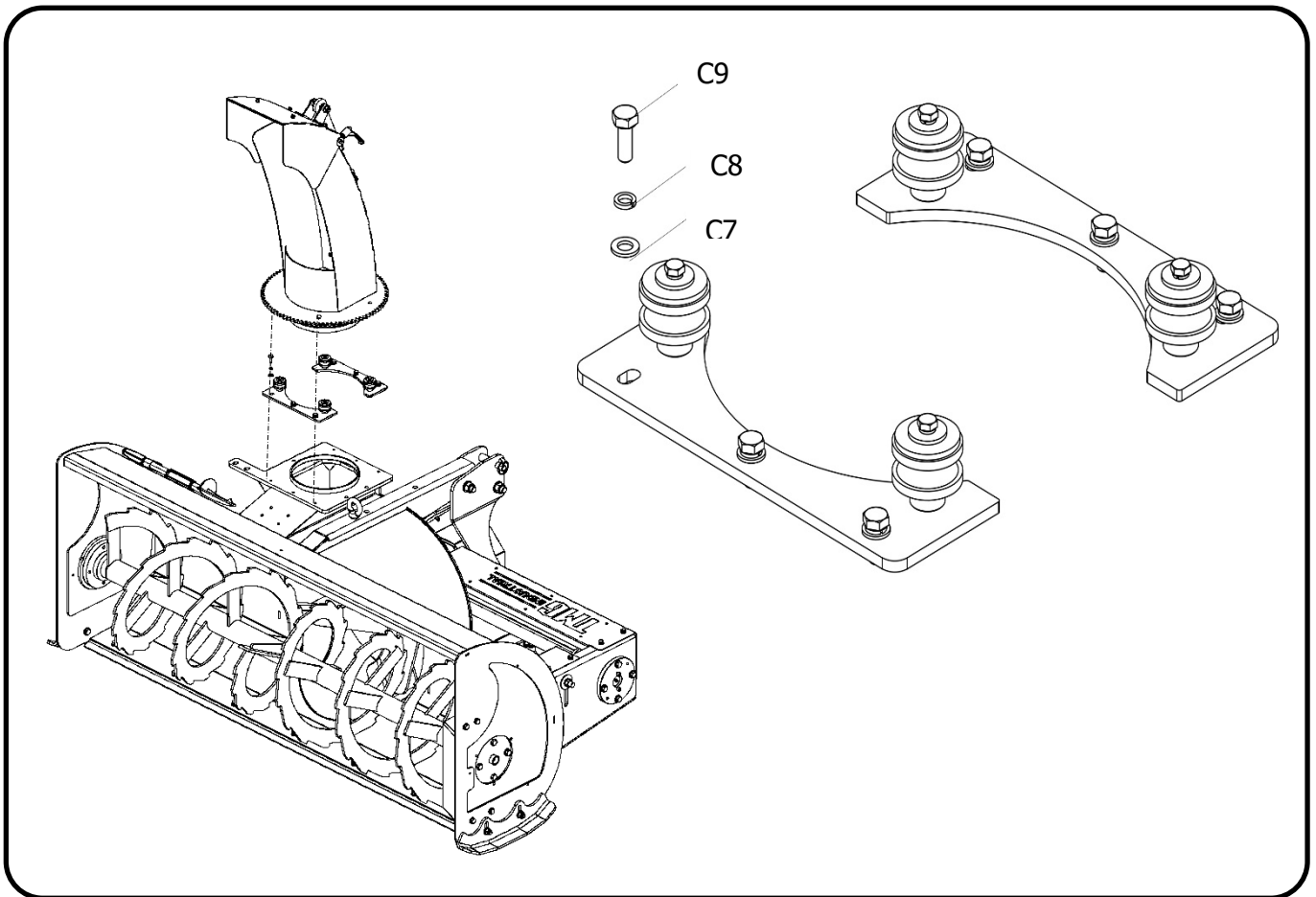

Installation steps:

1. Install the discharge port on the snow blower, unscrew the bolt on the machine first, remove one of the Limit plate of snow funnel, align the discharge port with the bayonet of the snow blower, and fix the limit plate with Plain washers (C7) , Full-thread hexagon bolts M8*20 (C9) and Spring washers (C8)
2. importance: All bolts are locked in place without shaking.



WARNING: Once the assembly bolts are not fastened in place, there will be abnormal noises when the machine is working.

PART NO.	DESCRIPTION	QTY	PART NO.	DESCRIPTION	QTY
C7	Plain washers $\varphi 8$	6	C9	Full-thread hexagon bolts M8*20	6
C8	Spring washers $\varphi 8$	6			

3. Install the hand push rod

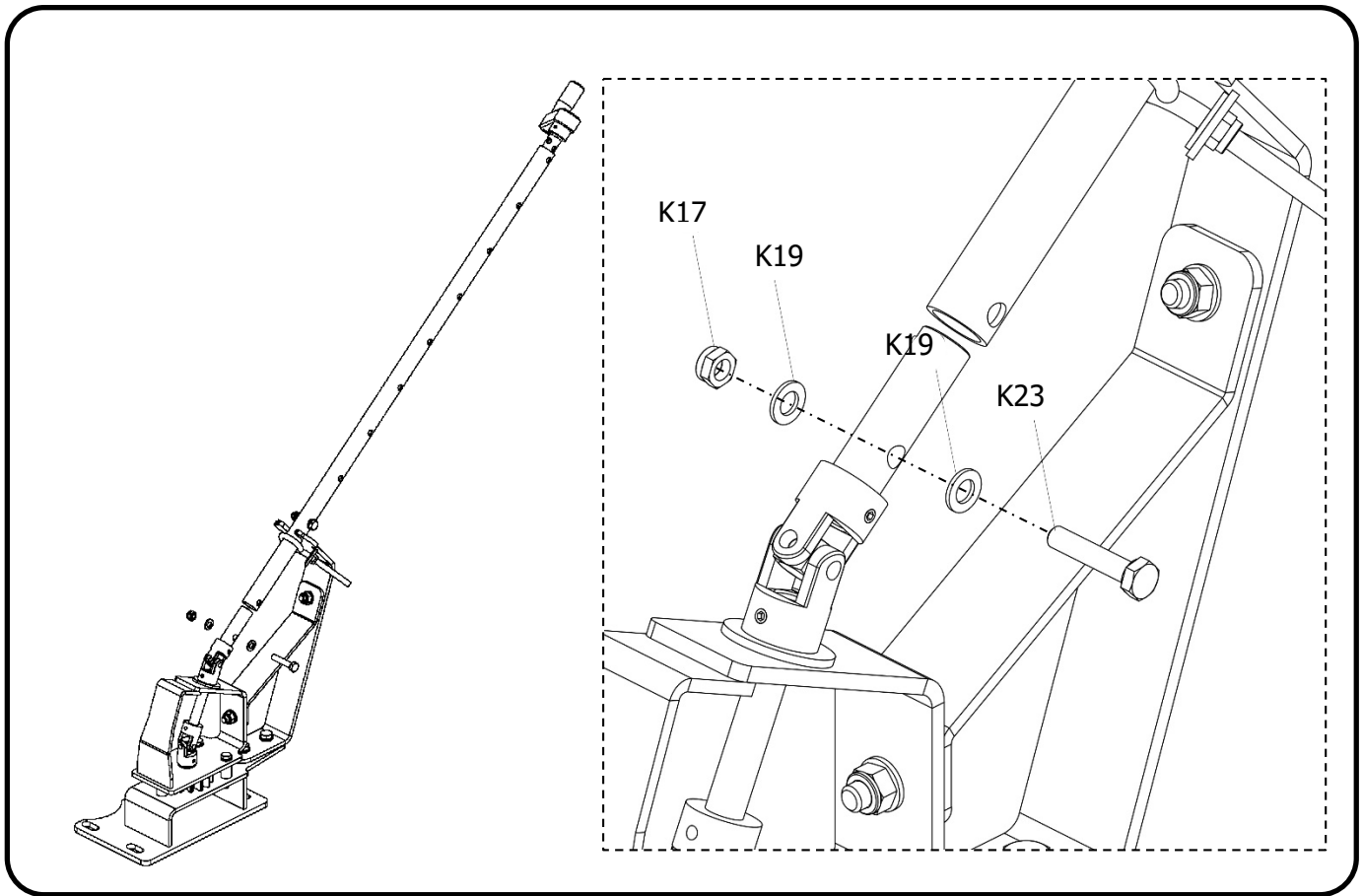

Installation steps:

1. Installation of hand push rod, when you receive the parcel, you need to install the push rod by yourself, the push rod will be fixed with Locknuts M8 (K17) , Plain washers $\varphi 8$ (K19) and Full-thread hexagon bolts M8*40 (K23) .
- 2 .Importance: All bolts are locked in place without shaking.



WARNING: Once the assembly bolts are not fastened in place, there will be abnormal noises when the machine is working.

PART NO.	DESCRIPTION	QTY	PART NO.	DESCRIPTION	QTY
K17	Locknuts M8	1	K23	Full-thread hexagon bolts M8*40	1
K19	Plain washers $\varphi 8$	2			

4. Install the hand push rod (Control of snow outlet left and right steering)

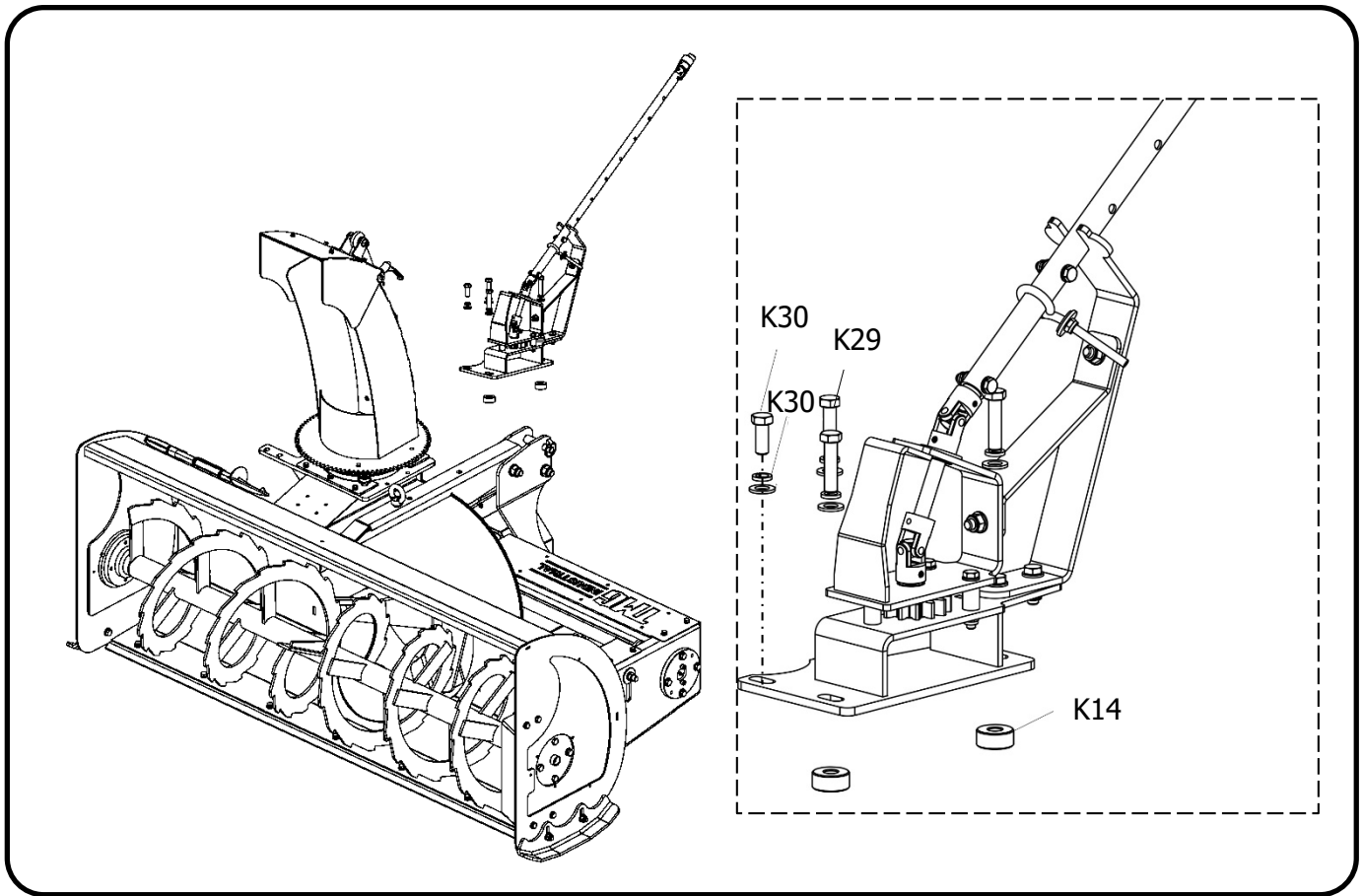

Installation steps:

1. Attach the hand push rod, first install fix the base plate of the hand push rod respectively with Full-thread hexagon bolts (K30), Spring washers (K28), Plain washers (K27) and Backing block (K14) to secure the remaining two holes in the base plate.
2. Importance: All bolts are locked in place without shaking.



WARNING: Once the assembly bolts are not fastened in place, there will be abnormal noises when the machine is working.

PART NO.	DESCRIPTION	QTY	PART NO.	DESCRIPTION	QTY
K14	Backing block	2	K29	Full-thread hexagon bolts M12*50	2
K27	Plain washers $\varphi 12$	4	K30	Full-thread hexagon bolts M12*30	2
K28	Spring washers $\varphi 12$	4			

CONNECTING TRACTOR

1. About the tractor attachment

Note: This Snow Blower is featured with a hitch design compatible with CAT.I and CAT.II. It can be attached to both the front and rear of a tractor.

Upper Hook-Up:

a. Attach Top center link to the snow blower with Hitch pin-Upper (#7) and pin (#6).

Lower Hook-Up:

b. Attach center 3-point link to the lower hitch clevis with Lower suspension pins (#2), Lower suspension quick change sleeves (#3) and secure with pin (#4) and pin (#5)

Quick hitch compatible

TBS series Snow Blower mounted with Quick hitch, with Suspension sleeve (#3) and Lower suspension quick change sleeve (#2)

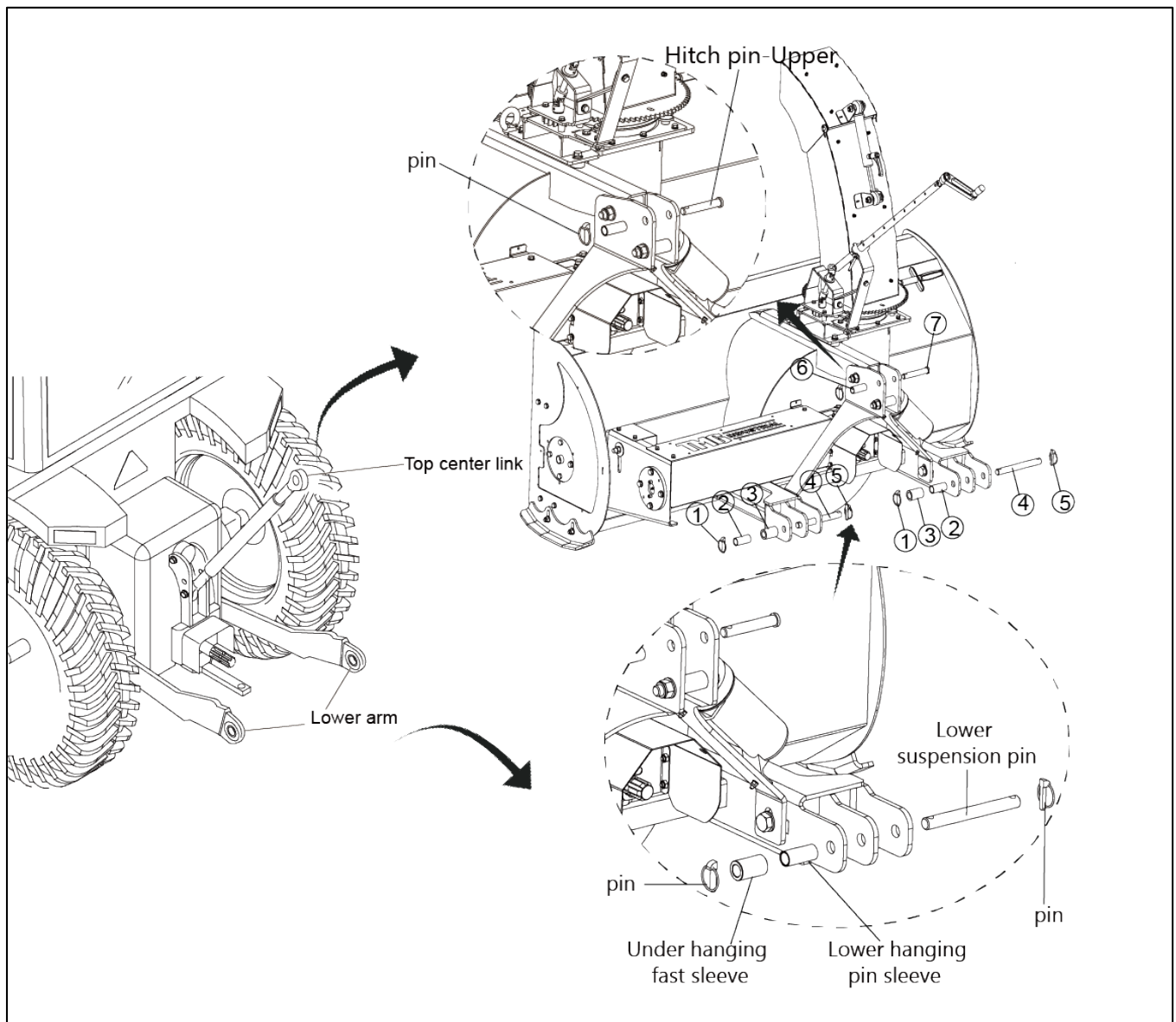

CHECK BEFORE OPERATING

1. Check before operating

Before operating the machine, check the following:

1. Check that the SNOW BLOWER is properly attached to the tractor by inserting the safety latch.
2. Check that moving parts are free of any debris or tangled material.
3. Check that the machine is lubricated according to the schedule listed in the Maintenance section.
4. Check and ensure that all guards, shields and guards are in place, secured and working as designed.
6. Check that the snow outfeed assembly is turned in the proper working direction.
7. Check that the fan and angle go in the right direction of movement, the fan runs in the clockwise direction (towards the machine) for the right, and the angle rotates in the working direction.
8. Check and tighten all fasteners. Make sure the equipment is in good condition.
9. Check that appropriate personal protective equipment is available and being used.
10. Check that jewellery and loose clothing are not worn. Long hair must be tied behind the head.

2. Before startup

Each operator must be trained in the proper operating procedures prior to operating the machine. The new machine or machine long unused, you must first idling operation.

- Review location of the controls, their function, and movement direction when activated.
- Follow the Pre-Operation Check
- Set up the machine correctly.

LUBRICATION POINTS SUMMARY

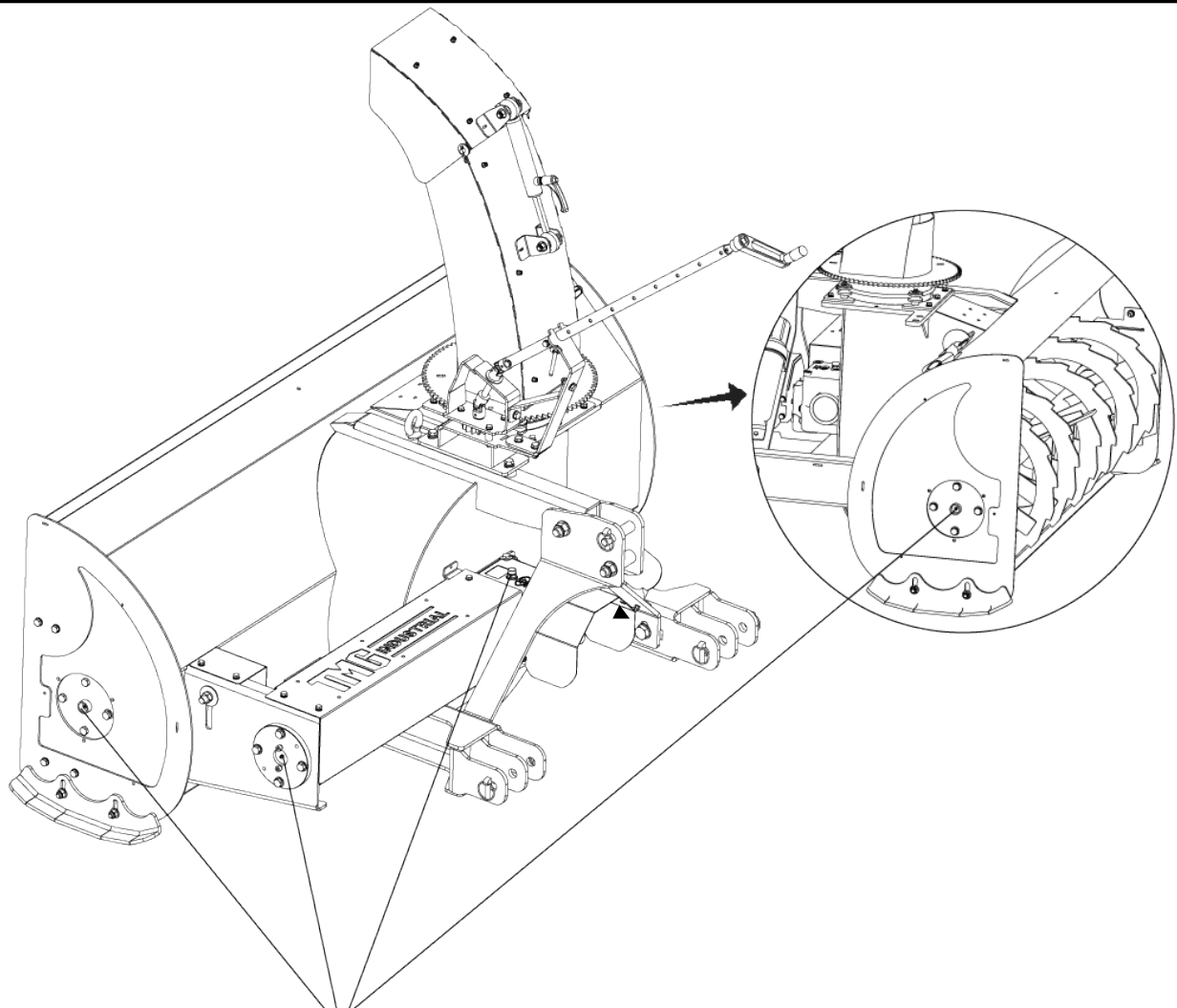

4 lubrication points
Gearbox oil - SAE 90, others - grease

PTO INSTALLATION

In some cases it will be necessary to shorten the PTO assembly to match your particular tractor. The following procedure should be used:

1. Check that the driveline is the correct length. The minimum coupling length (overlap) must be no less than 150mm (6 inches) in each work position. The driveline travel must still be about 25 mm (1 inch) in the maximum coupling (overlap) position.

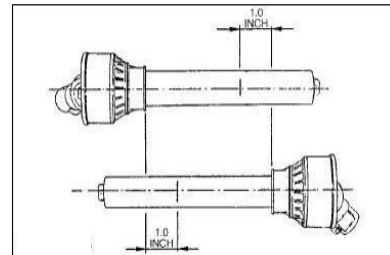

2. Always couple the two end yokes of the driveline, check that they are locked in place.

To achieve this condition, completely insert the latch pin into the groove in the PTO shaft on the tractor. Install the bolt through the yoke and input the shaft on the mixer. An unlocked shaft will slip out of position, causing notable mechanical damage and serious injury to anyone nearby.

If the driveline is too long, it should be shortened in the following way:

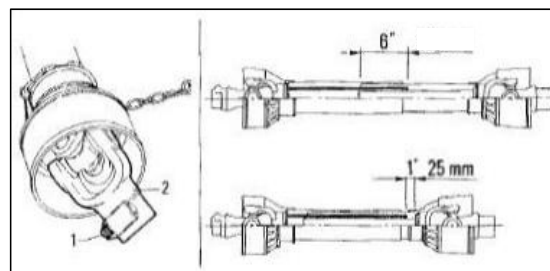

- Set the machine PTO input shaft at a minimum distance from the tractor PTO stub shaft, then set the tractor brakes, and switch the engine off.
- Separate the two halves of the driveline. Install the female part into the tractor PTO and the male part on the machine PTO, checking that the position is correct by means of the latch pin.
- Place the two halves of the driveline together, keeping them parallel. Using a felt-tip pen, mark the place where the two halves must be shortened, measuring 1.0 inch from the beginning of each half, as shown in Figure. Double check before making any cuts. Cut PTO drivelines cannot be returned.
- Raise and lower the mixer to determine the position with the greatest distance between the PTO shaft and mixer input shaft. Shut the tractor off, leaving the mixer in the position of greatest distance between shafts. **SECURELY BLOCK THE MIXER IN POSITION.**
- Hold the driveline sections parallel to each other and check for a minimum of 6" (15cm) overlap. If the driveline has been marked for cutting, the overlap will be the distance between the two marks. If the driveline has less than the minimum overlap, do not use it. Contact an authorized dealer.
- If the driveline must be cut to a shorter length, it in a well-padded vise to prevent the shield.
- Repeat the procedure on the other driveline half. Remove all burrs and cuttings.
- Apply multi-purpose grease to the inside of the outer (female) driveline section. Assemble the driveline and install on the tractor. Pull on each driveline section to be sure the yokes lock into place. Make certain the driveline shielding is in place and in good condition.

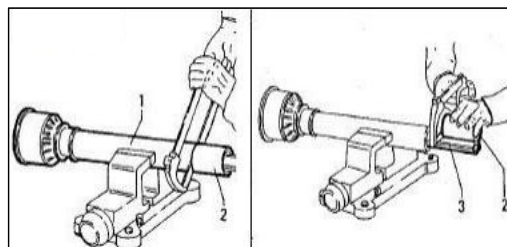

OPERATION

1. SNOW REMOVAL METHODS

When removing snow, do not use the snow blower as a dozer blade to push snow. Let the snow blower work its way through deep drifts. If the speed of your tractor is too fast, the snow blower may become overloaded and clog. For best results, raise the snow blower and remove a top layer of snow. A second pass with the snow blower will remove the remaining snow.

IMPORTANT : Use full RPM power when removing wet, sticky snow. Low RPM power will tend to clog

WARNING: Do not use hands or feet to unclog chute. Do not attempt to clear clogged chute of snow while tractor engine is running. If the chute clogs, disengage the drive shaft, shut off the tractor engine, remove the ignition key, wait for all movement to stop, and then clear the snow from the chute.

A definite pattern of operation is required to thoroughly clean the snow area. These patterns will avoid throwing snow in unwanted places as well as eliminating a second removal of snow

PATTERN 1

DISCHARGE SNOW BOTH SIDES

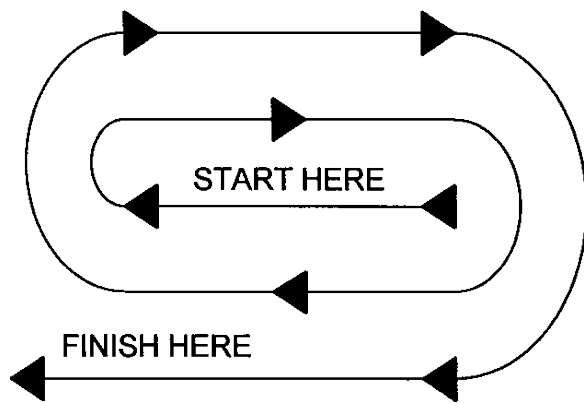

DISCHARGE SNOW BOTH SIDES

PATTERN 2

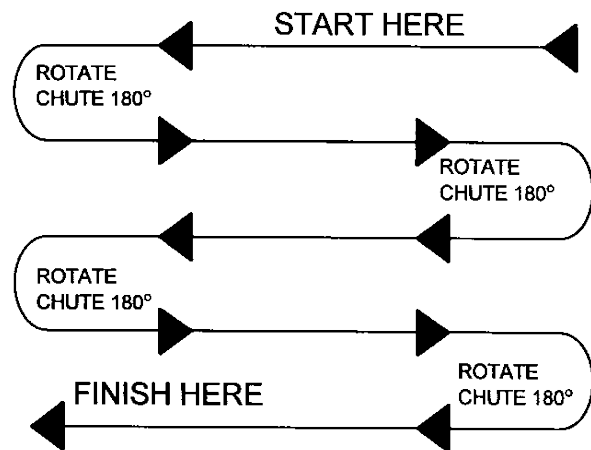

DISCHARGE SNOW THIS SIDE ONLY

PATTERN1:

Where it is possible to throw the snow to the left and right (above), as on a long driveway, it is advantageous to start in the middle. Plow from one end to the other, throwing snow to both sides without changing the direction of the discharge guide.

PATTERN2:

If the snow can only be thrown to one side of the driveway or sidewalk (above), start on the opposite side. At the end of the first pass, rotate the discharge guide 180 degrees for the return pass. At the end of each succeeding pass, rotate the discharge guide 180 degrees to maintain direction of throw in the same area

OPERATING FINISH



WARNING: Provide adequate blocking before working under the snow blower when in the raised position.

1. Park the machine on dry, level ground. Turn ignition to OFF and remove the key.
2. Allow the engine to idle for 5 minutes to cool.
3. Remove large debris such as clumps of dirt, grass, crop residue, etc. from machine.
4. Inspect machine and replace worn or damaged parts.
5. Replace any safety decals that are missing or not readable.

1. DRIVELINE

IMPORTANT: When the snow blower is not used for more than two weeks, perform driveline maintenance and always store it in a dry place, away from bad weather conditions.

2. BOLTS

Check bolts for tightness to ensure the blower is in safe working condition.

3. Gearbox

NOTE: Do not overfill! Snow Blower should be level when checking oil. Oil expands when hot, therefore, always check oil level when cold. Remove oil level plug shown with arrow. If oil is below bottom of plug hole, add recommended gear lube through oil level plug hole until oil flows out of the hole. Reinstall and tighten oil level plug.

4. LUBRICATION

Use oil or a grease gun and lubricate as follows:

DESCRIPTION	INTERVAL	LUBRICATION REQUIRED
Driveline	8 hours	Grease each universal joint. Separate the sliding parts and cover each one of them with grease
	16 hours	Oil the push pins
Chain	4 hours and after each operation	Lubricate with chain lube
Drive Shaft	24 hours of operation	Grease fitting on shear plate
Gearbox	Every month	Check oil level. If needed, add 1 Qt SAE 90 oil
	250 hours	Replace oil
Bearing	24 hours of operation	Grease each auger bearing

MAINTENANCE SCHEDULE

Perform maintenance procedures at time shown or hour interval, whichever comes first.

Inspection unit list	Inspection time
Grease Gearbox	Regular refueling
Grease PTO shaft (if equipped)	Every 50 hours of operation or weekly
Check condition of bucket teeth	Every 50 hours of operation or weekly
Clean machine—remove any entangled material or debris build-up.	Every 100 hours of operation or annually
Check oil level in PTO Pump Kit reservoir (if equipped)	Every 100 hours of operation or annually
Replace return filter on PTO Pump Kit (if equipped)	Every 500 hours of operation

TROUBLESHOOTING

Problem	Solution
Not Throwing Snow	Operate at full throttle (540 PTO rpm) , check PTO speed and tractor engine Shift transmission to a lower gear Discharge chute is plugged . Clear chute
Excessive Vibration	Discharge fan blade is bent or missing
Gearbox Noisy	Check oil level
Auger is Not Turning	Replace shear bolts on auger torque limited
Discharge Fan is Not Turning	Tighten the clutch bolt of the PTO drive shaft
Snow not completely removed from surface • Skid shoe needs adjustment	<ul style="list-style-type: none"> • Disengage the auger and drive controls, wait ten seconds for the auger to stop rotating. Loosen the two hex nuts on the skid shoe on either side of the snow blower. • Raise the skid shoes so the entire bottom surface of the skid shoe rests on the ground evenly. Retighten the hex nuts on both sides. This adjustment allows the auger to come into closer contact with the ground surface.
Snow blower continually clogs • Machine does not propel itself forward	<ul style="list-style-type: none"> • Operate at a slower pace to allow the snow blower to dispel snow through the discharge chute. • Forcing the snow blower to move faster than it can remove the snow will result in clogged auger and/or discharge chute. Do not overload the blower in extremely heavy or wet snow.

EXPLODED VIEW & PARTS LIST

1. Snow blower

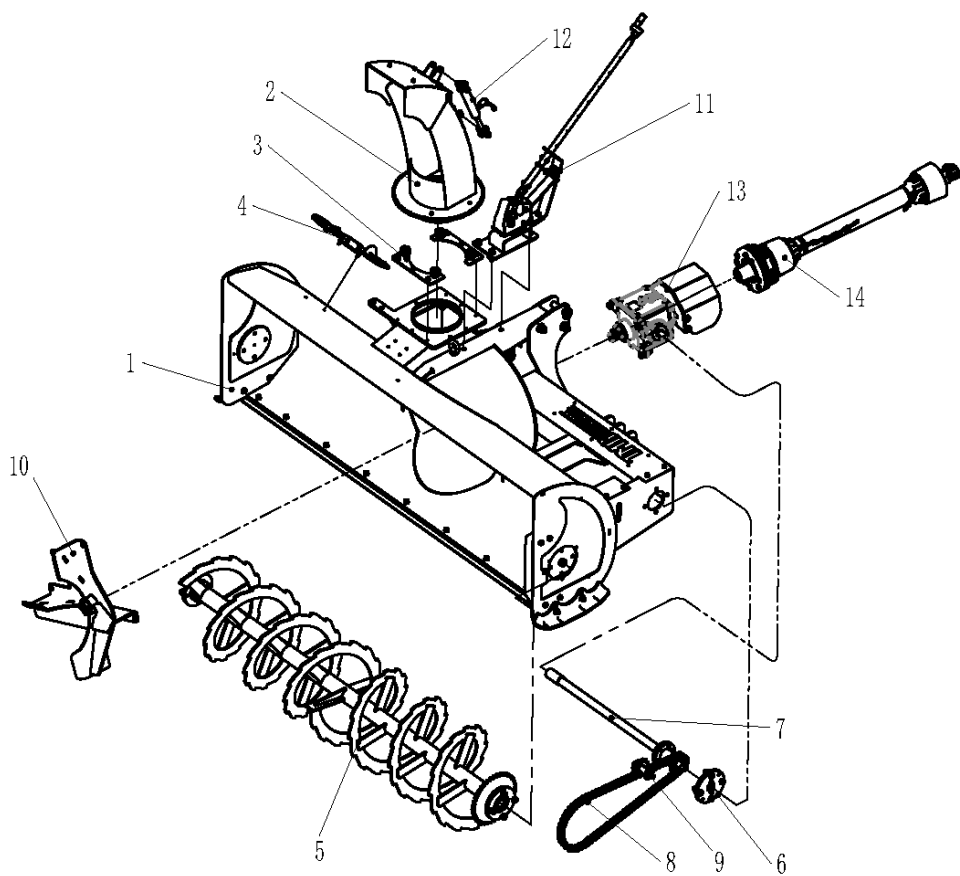

PARTS LIST

PART NO.	DESCRIPTION	QTY	PART NO.	DESCRIPTION	QTY
1	Bucket body assembly	1	8	Roller chain	1
2	Outfeed assembly	1	9	Tensioner as	1
3	Pressboard assembly	2	10	Fan assembly	1
4	Snow shovel assembly	1	11	Handle as-hand	1
5	Stirring assembly	1	12	Push rod as-hand	1
6	Bearing block as-drive shaft	1	13	Gearbox as-rear	1
7	Drive as-torque limiter	1	14	PTO Drive Shaft (with Clutch)	1

2. Bucket body assembly

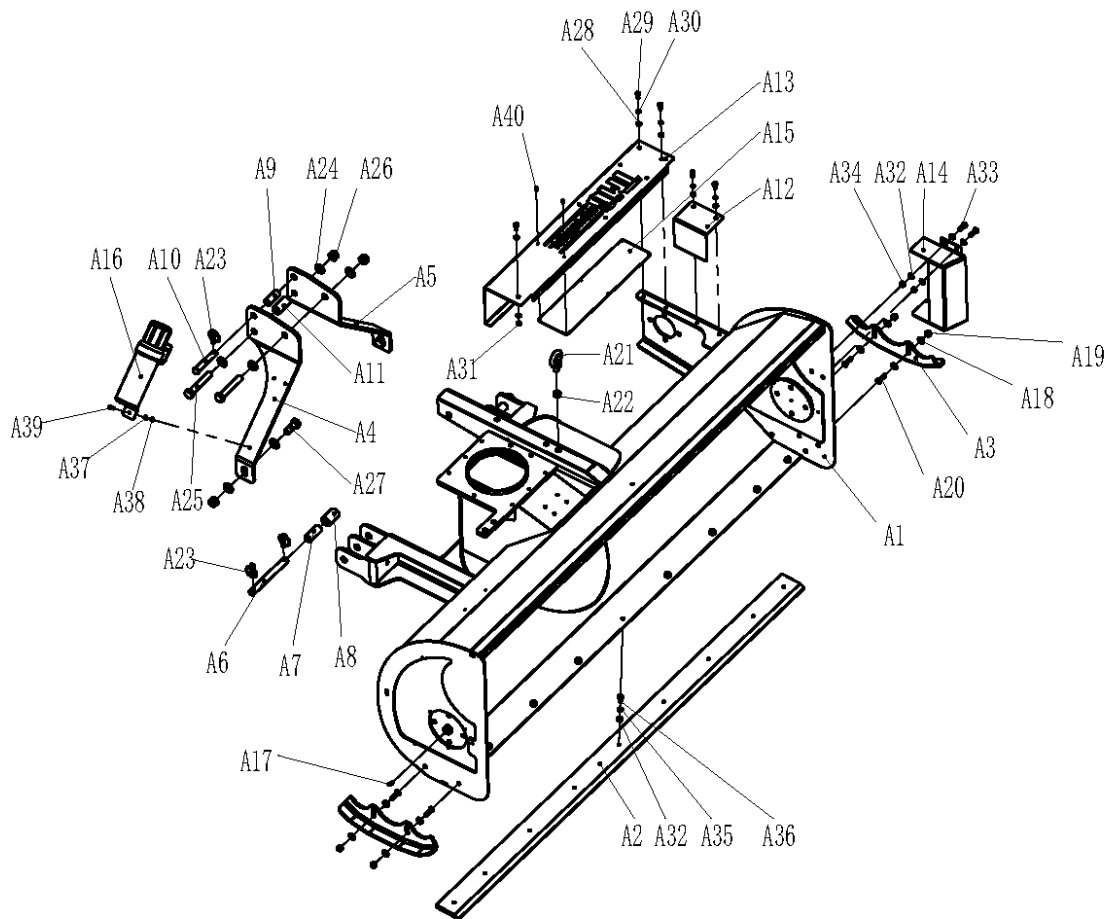

PARTS LIST

PART NO.	DESCRIPTION	QTY	PART NO.	DESCRIPTION	QTY
A1	Hood weldment	1	A21	Eye bolt M16*28	1
A2	Blade	1	A22	Hexagon thin nut M16	1
A3	skid plates	2	A23	Pins φ12	5
A4	Left side of suspension plate	1	A24	Plain washers φ20	8
A5	Right side of suspension plate	1	A25	Hexagon head bolts M20*120	2
A6	Lower suspension pins	2	A26	Locknuts M20	4
A7	Cat2 Lower hanging pin sleeves	2	A27	Full-thread hexagon bolts M20*50	2
A8	Under hanging fast sleeves	2	A28	Plain washers 8	6
A9	Suspension sleeve	1	A29	Full-thread hexagon bolts M8*20	5
A10	Hitch pin-Upper	1	A30	Spring washers 8	4
A11	Suspension sleeve	1	A31	Locknut M8	1
A12	Sprocket cover	1	A32	Plain washers 10	17
A13	Transmission shaft cover	1	A33	Full-thread hexagon bolts M10*30	4
A14	Front baffle	1	A34	Locknuts M10	4
A15	Color board	1	A35	Spring washers 10	9
A16	Manual canister	1	A36	Full-thread hexagon bolts M10*20	9
A17	Grease nipples M6	2	A37	Plain washers 6	3
A18	Plain washers φ12	8	A38	Locknuts M6	3
A19	Locknuts M12	4	A39	Full-thread hexagon bolts M6*30	3
A20	Full-thread hexagon bolts M12*35	4	A40	Open end Oind rivets 4*10	10

3. Outfeed assembly

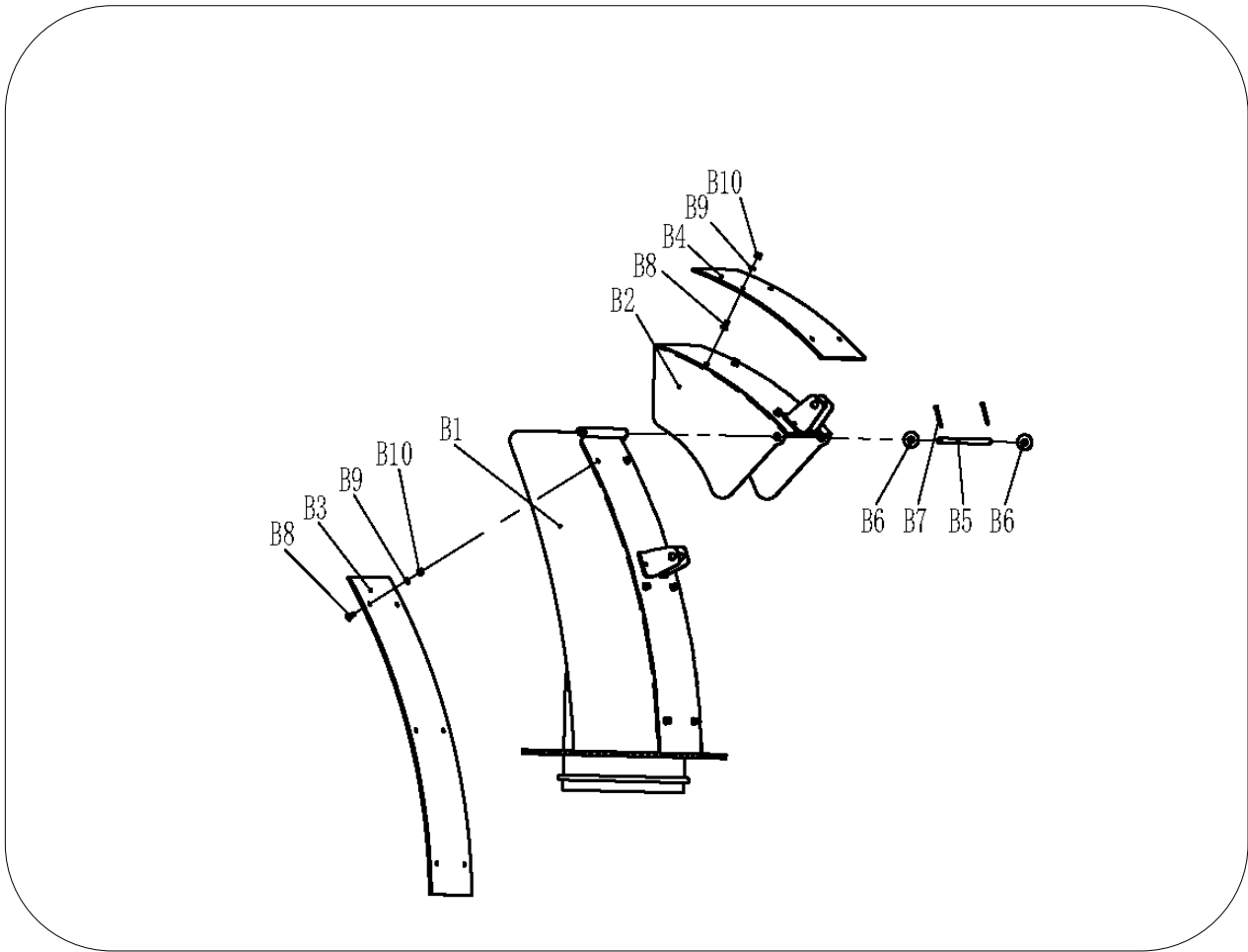

PARTS LIST

PART NO.	DESCRIPTION	QTY	PART NO.	DESCRIPTION	QTY
B1	Welding parts of snow discharge cylinder	1	B6	Large plain washers $\phi 10$	2
B2	Flap weldment	1	B7	Split pins 4*32	2
B3	Back panel veneer	1	B8	HSCS-Countersunk M6*16	10
B4	Flap cover plate	1	B9	Plain washers $\phi 6$	10
B5	Install pin	1	B10	Locknuts M6	10

4. Pressboard assembly

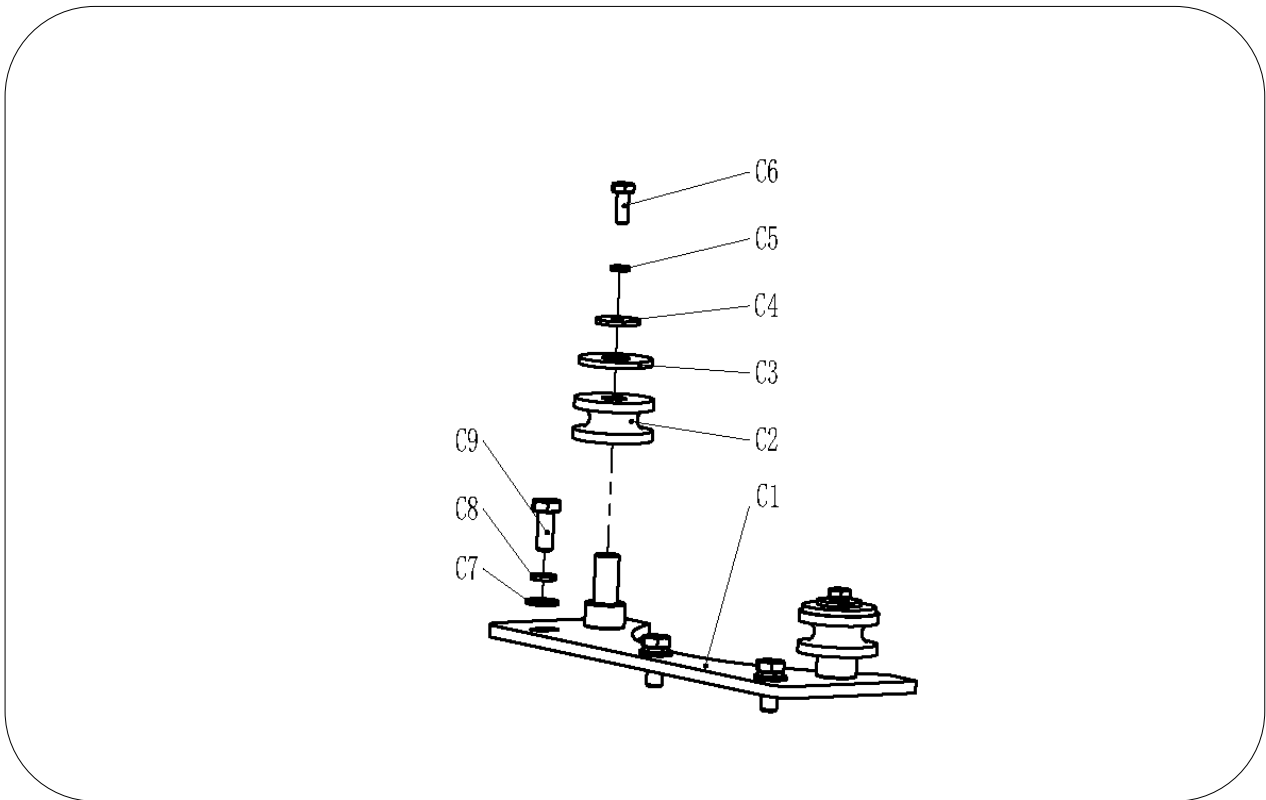

PARTS LIST

PART NO.	DESCRIPTION	QTY	PART NO.	DESCRIPTION	QTY
C1	Press plate weldment	1	C6	Full-thread hexagon bolts M6*16	2
C2	pulley	2	C7	Plain washers $\phi 8$	3
C3	Large plain washers $\phi 12$	2	C8	Spring washers $\phi 8$	3
C4	Extra Large plain washer $\phi 6$	2	C9	Full-thread hexagon bolts M8*20	3
C5	Spring washers $\phi 6$	2			

5.Snow shovel assembly

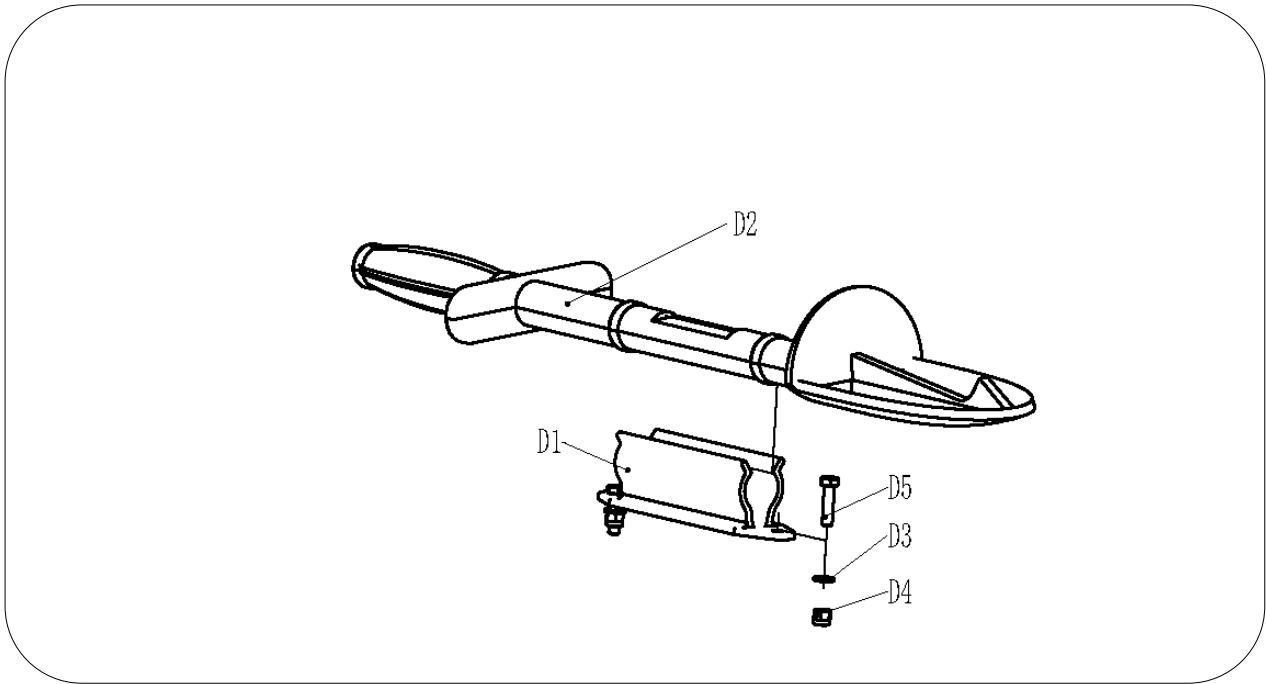

PARTS LIST

PART NO.	DESCRIPTION	QTY	PART NO.	DESCRIPTION	QTY
D1	Rubber T1	1	D4	Locknuts M6	2
D2	Rubber T2	1	D5	Full-thread hexagon bolts M5*20	2
D3	Plain washers $\phi 5$	2			

6. Stirring assembly

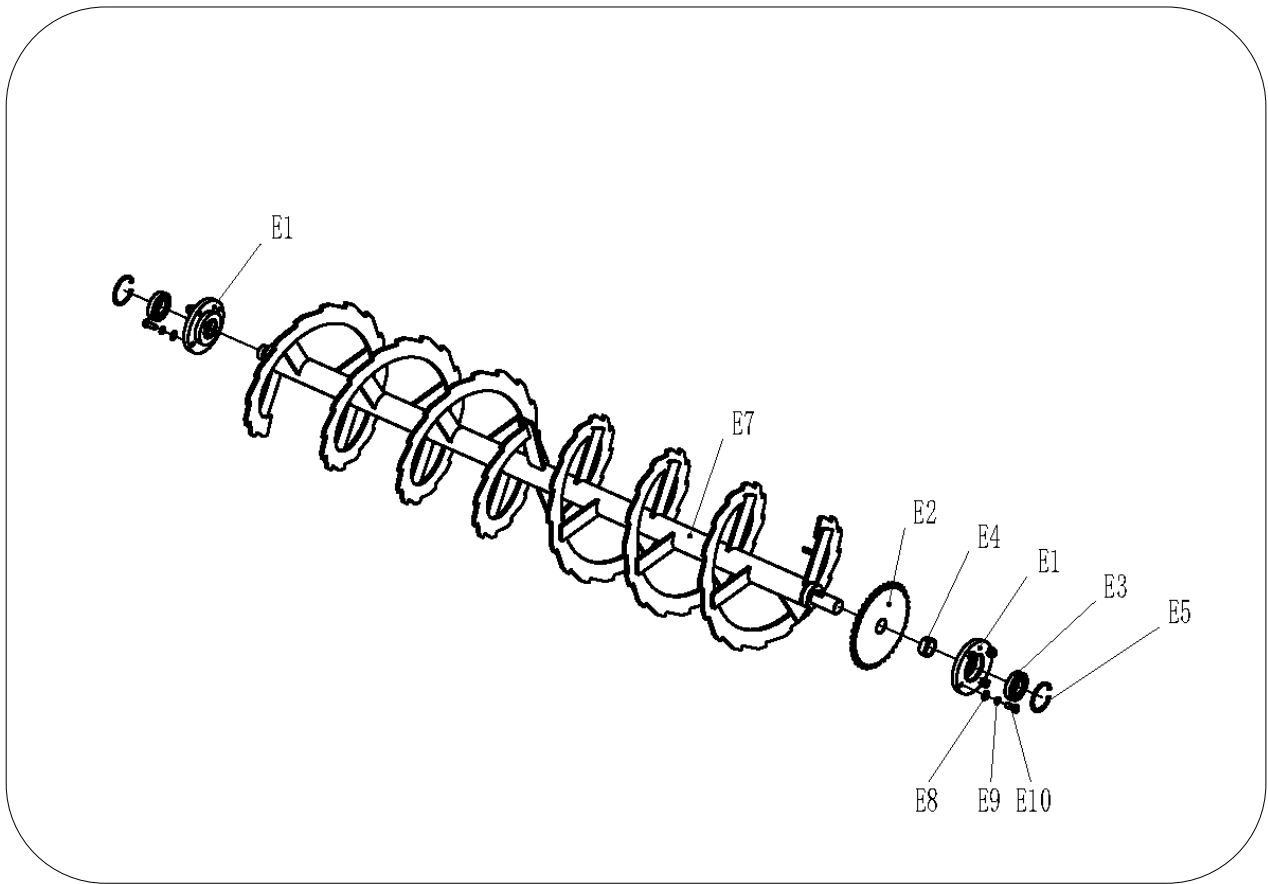

PARTS LIST

PART NO.	DESCRIPTION	QTY	PART NO.	DESCRIPTION	QTY
E1	Agitating bearing seat	2	E6	Key 8*30	1
E2	Chain wheel	1	E7	Stir up welding parts	1
E3	Deep groove ball bearing 6208-RS	2	E8	Plain washers φ12	8
E4	Stirring shaft end bushing	1	E9	Spring washers φ12	8
E5	Elastic retainer ring for hole 80A	2	E10	Full-thread hexagon bolts M12*30	8

7. Bearing block as-drive shaft

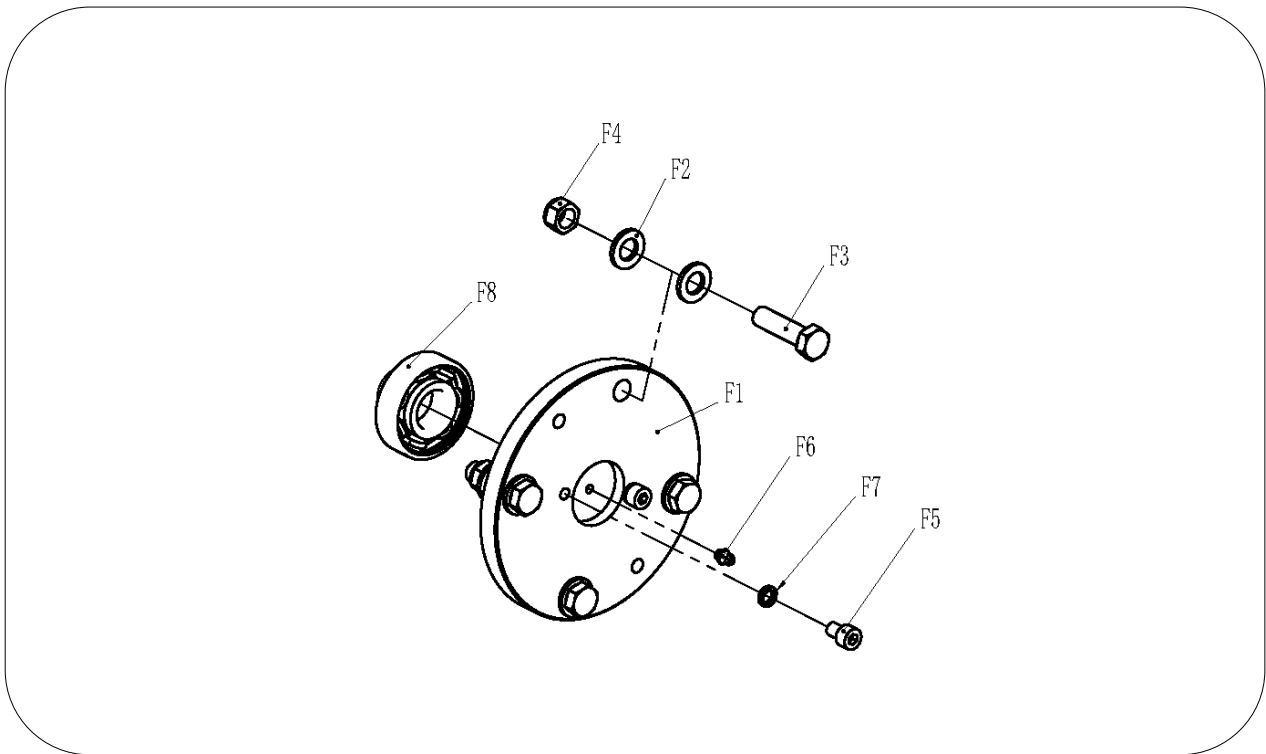

PARTS LIST

PART NO.	DESCRIPTION	QTY	PART NO.	DESCRIPTION	QTY
F1	Drive shaft bearing seat	1	F5	Hexagon socket head cap screws M8*12	2
F2	Plain washer ϕ 12	8	F6	Grease nipples M6	1
F3	Full-thread hexagon bolts M12*45	4	F7	Spring washers ϕ 8	2
F4	Locknuts M12	4	F8	Deep groove ball bearing 6305-RZ	1

7. Drive as-torque limite

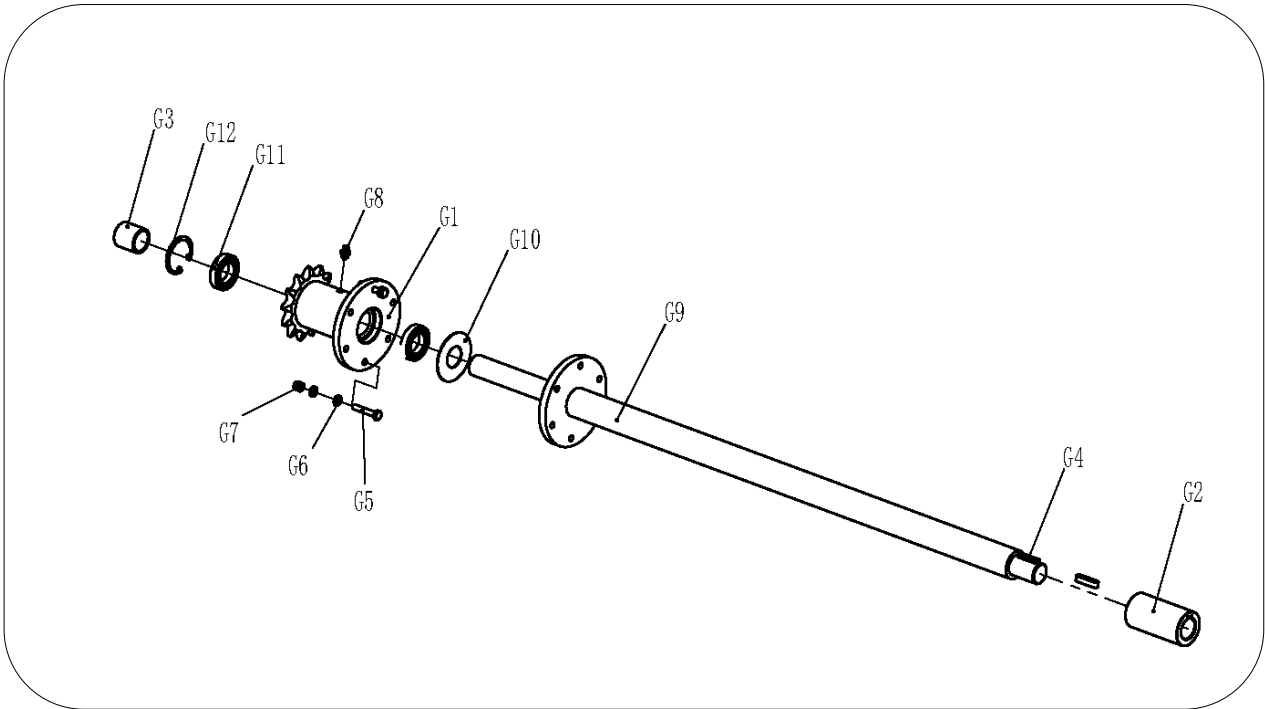

PARTS LIST

PART NO.	DESCRIPTION	QTY	PART NO.	DESCRIPTION	QTY
G1	Clutch drive shaft welding	1	G7	Full-thread hexagon bolts M6*35	2
G2	Chain wheel	1	G8	Locknuts M6	2
G3	Gearbox connecting sleeve	1	G9	Sprocket bushing	1
G4	Key 8*32	2	G10	Rubber	1
G5	Grease nipple M8*1	1	G11	Deep groove ball bearing 61905-2RS	2
G6	Plain washer φ6	4	G12	Elastic retainer ring for hole 42A	1

8. Roller chain

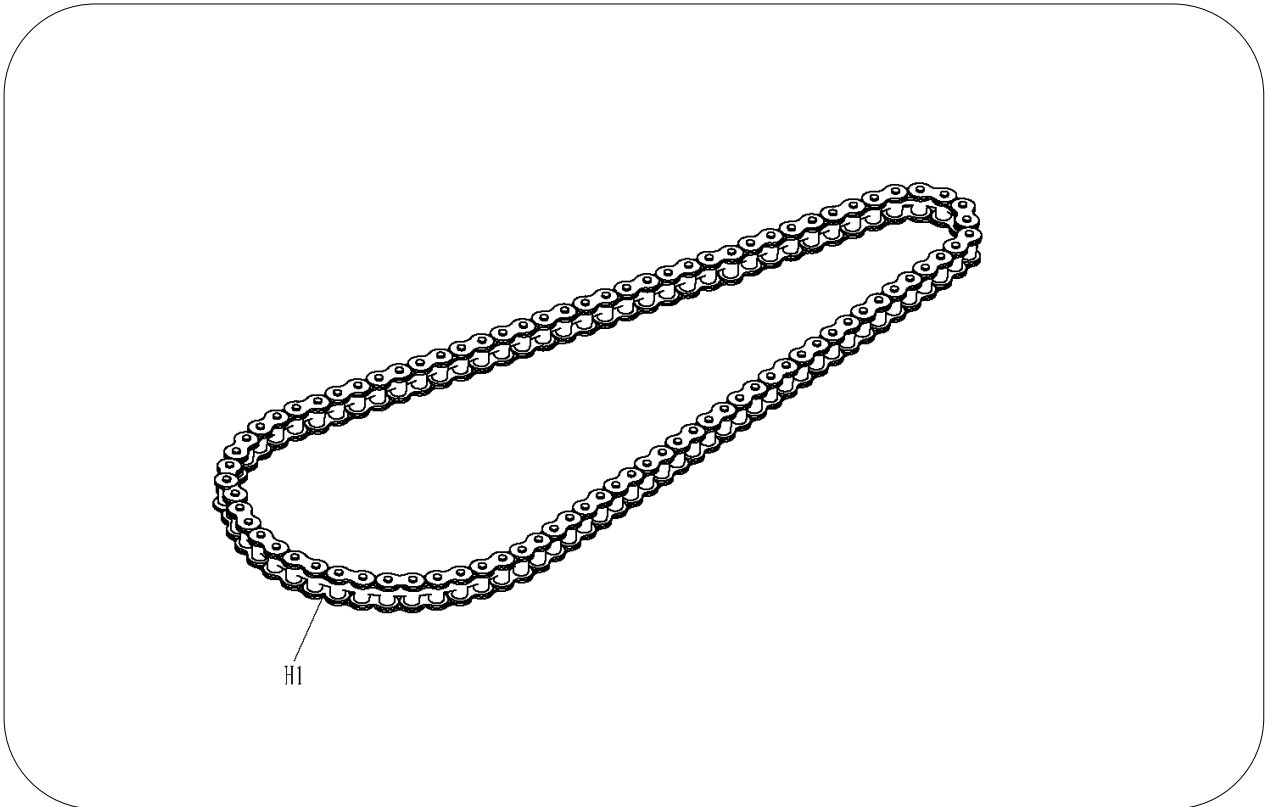

PARTS LIST

PART NO.	DESCRIPTION	QTY
H1	Roller chain GB/T 1243-12A-1*86	1

10. Tensioner as

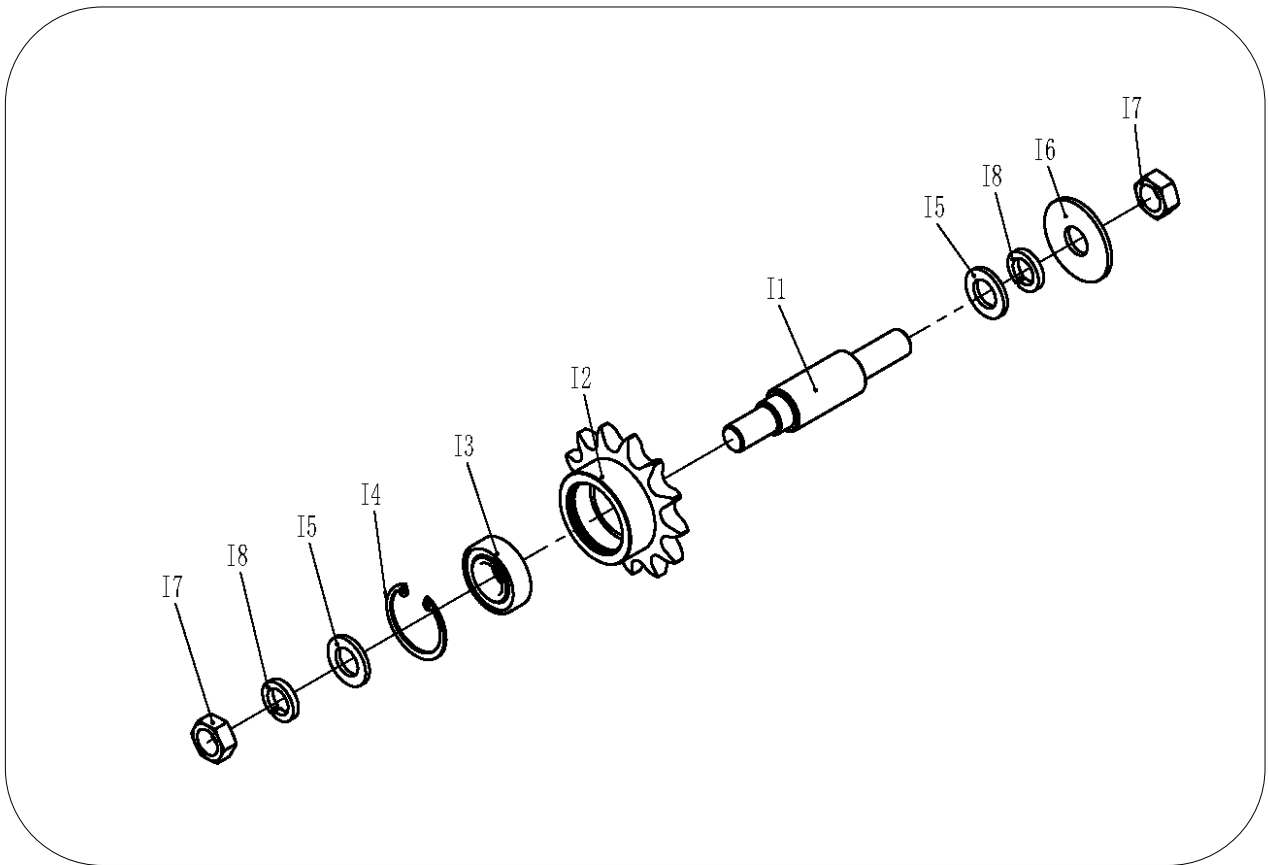

PARTS LIST

PART NO.	DESCRIPTION	QTY	PART NO.	DESCRIPTION	QTY
I1	Tighten axle	1	I5	Plain washers φ16	2
I2	Chain wheel	1	I6	Large plain washers φ16	1
I3	Deep groove ball bearing 6004-2RS	1	I7	Hexagon Nuts M5	2
I4	Elastic retaining ring 42A for holes	1	I8	Spring washers φ16	2

11.Fan assembly

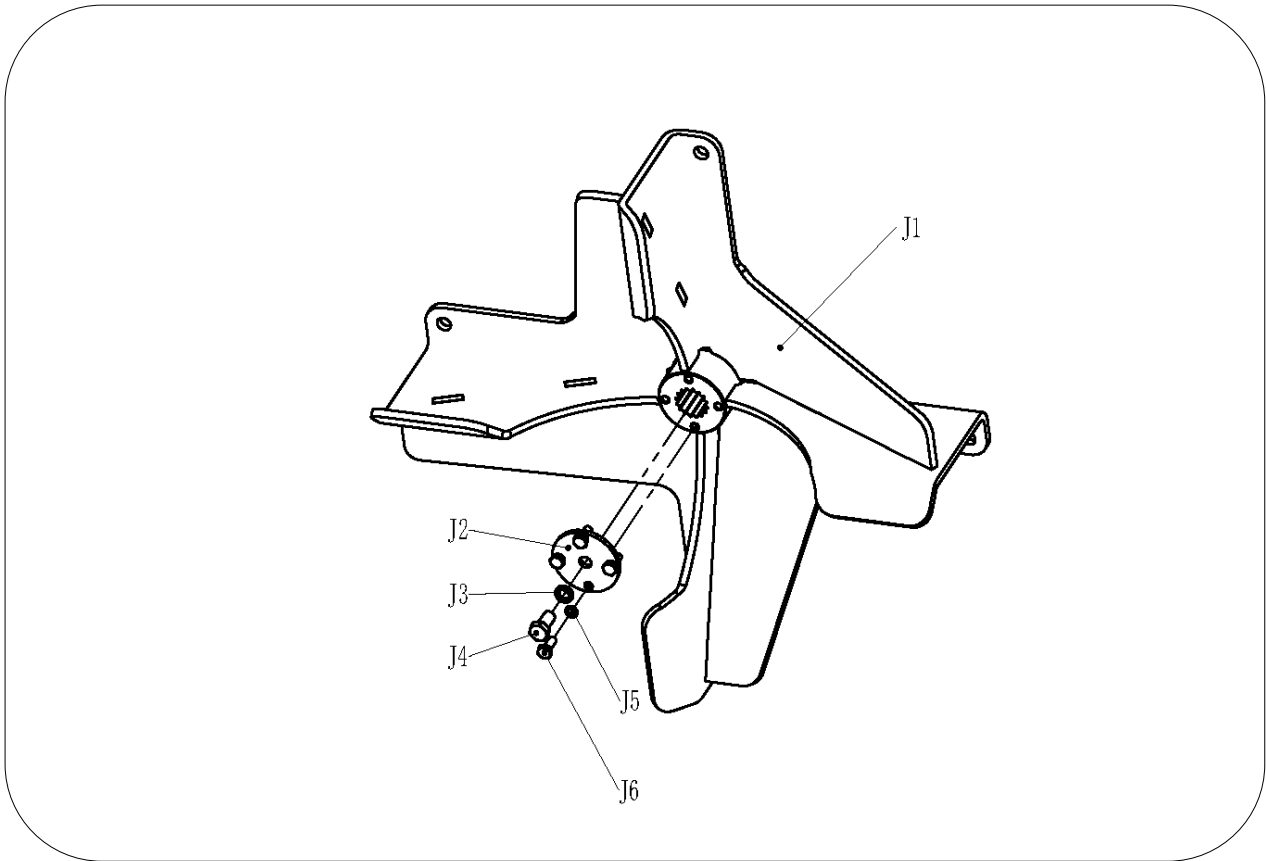

PARTS LIST

PART NO.	DESCRIPTION	QTY	PART NO.	DESCRIPTION	QTY
J1	Fan weldment	1	J4	Full-thread hexagon bolts M12*25	1
J2	Fan gasket	1	J5	Spring washers $\phi 8$	4
J3	Spring washers $\phi 12$	1	J6	Full-thread hexagon bolts M8*20	4

12. Handle as-hand

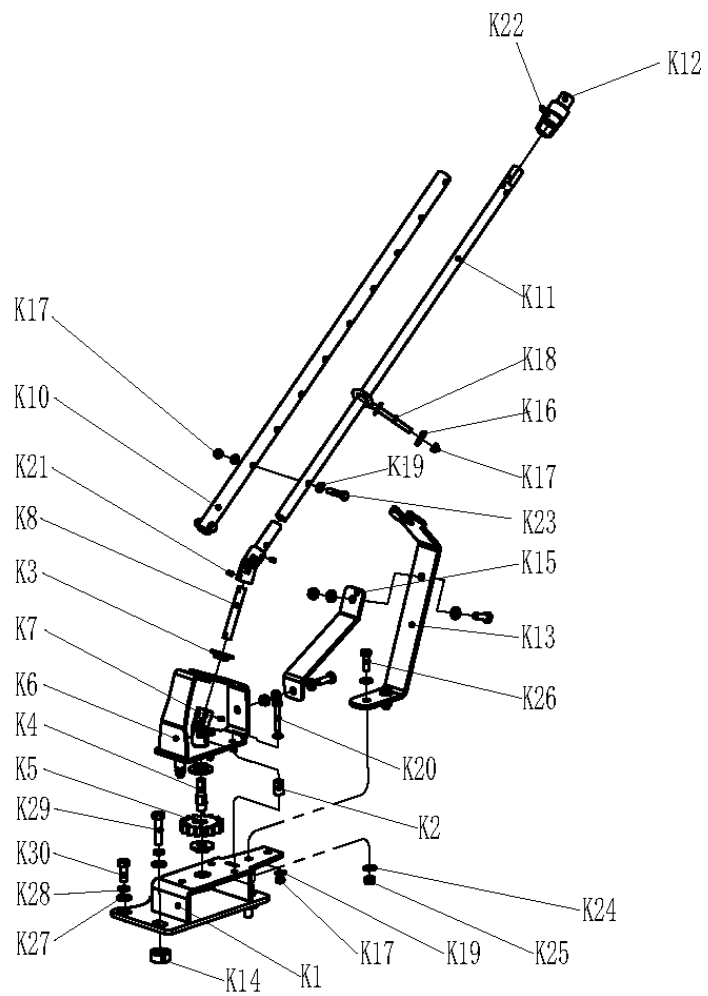

PARTS LIST

PART NO.	DESCRIPTION	QTY	PART NO.	DESCRIPTION	QTY
K1	Handle mount welded	1	K16	Extra Large plain washers $\phi 8$	1
K2	Positioning sleeve	3	K17	Locknuts M8	6
K3	Rotary spacer	3	K18	Welding of eyebolt	1
K4	Link bar	1	K19	Plain washers $\phi 8$	10
K5	Gear	1	K20	Full-thread hexagon bolts M8*50	3
K6	Pinion clamp welding	1	K21	Hexagon socket screws with flat point M6*10	4
K7	Cardan SQR.G14	2	K22	Hexagon socket screws with flat point M5*8	1
K8	Connecting rod	1	K23	Full-thread hexagon bolts M8*40	2
K9	Handle link bar	1	K24	Plain washers $\phi 10$	8
K10	Extension bar	1	K25	Locknuts M10	4
K11	Adjusting rod weldment	1	K26	Full-thread hexagon bolts M10*30	4
K12	Handle CH06.424	1	K27	Plain washers $\phi 12$	4
K13	Manual rocker support plate	1	K28	Spring washers $\phi 12$	4
K14	Backing block	2	K29	Full-thread hexagon bolts M12*50	2
K15	Tie bar	1	K30	Full-thread hexagon bolts M12*30	2

13. Push rod as-hand

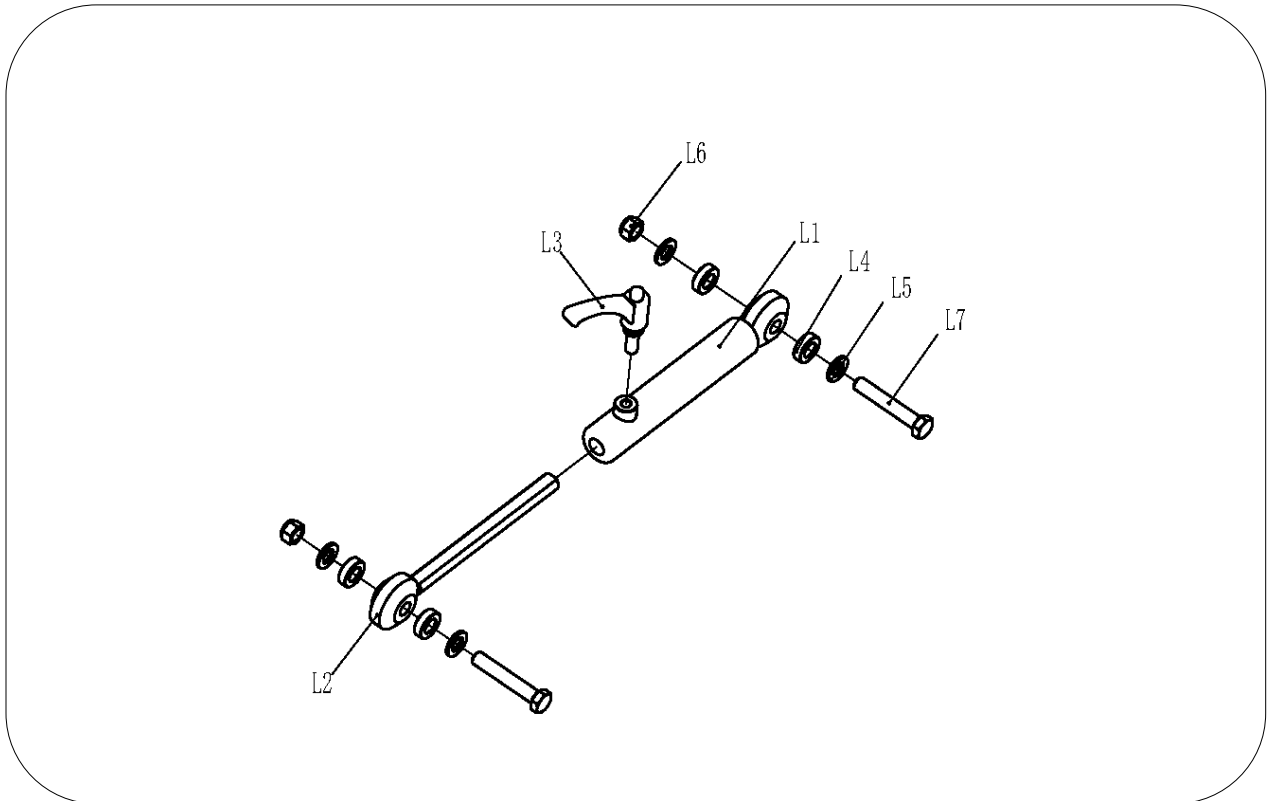

PARTS LIST

PART NO.	DESCRIPTION	QTY	PART NO.	DESCRIPTION	QTY
L1	Cylinder body welding parts	1	L5	Plain washers $\phi 12$	4
L2	Push rod welding parts	1	L6	Locknuts M12	2
L3	Handle M10*1.25*25	1	L7	Full-thread hexagon bolts M12*70	2
L4	Spacer sleeves	4			

14. Gearbox as-rear

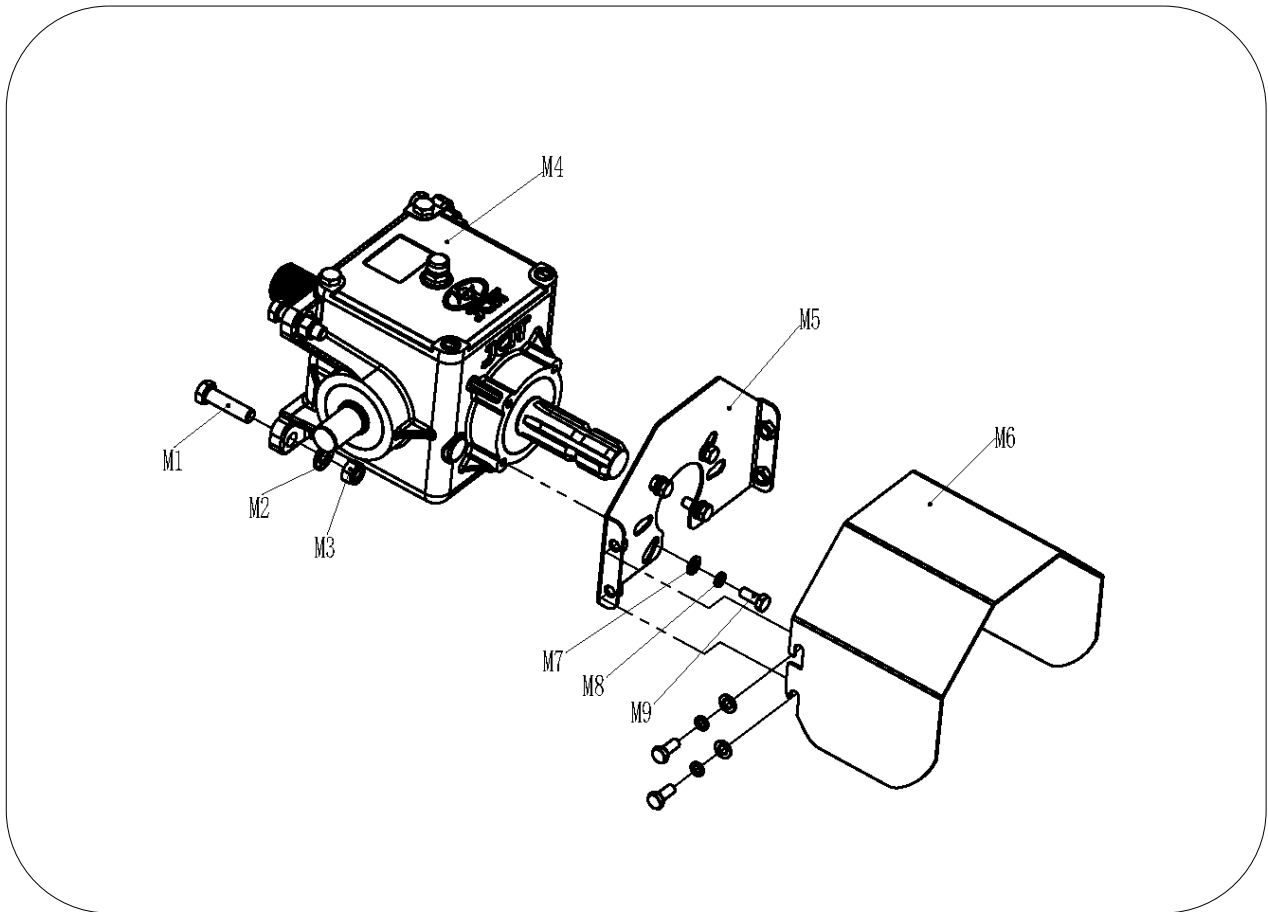

PARTS LIST

PART NO.	DESCRIPTION	QTY	PART NO.	DESCRIPTION	QTY
M1	Full-thread hexagon bolts M12*45	4	M6	PTO Guard	1
M2	Plain washers $\phi 12$	4	M7	Plain washers $\phi 12$	8
M3	Locknuts M12	4	M8	Spring washers $\phi 12$	8
M4	Gear box KF038R100J0200 (TMG)	1	M9	Full-thread hexagon bolts M12*20	8
M5	Welding of shield bottom plate	1			

15. PTO Drive Shaft (with Clutch)

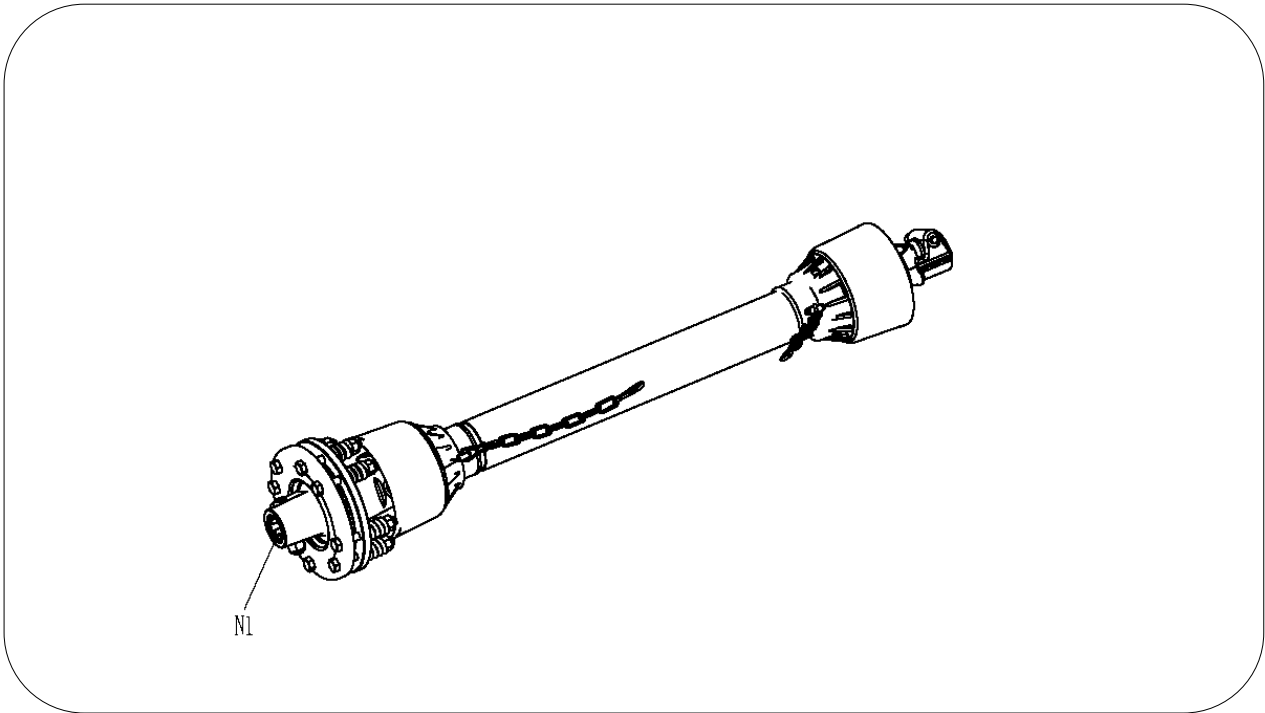

PARTS LIST

PART NO.	DESCRIPTION	QTY
N1	PTO Drive Shaft (with Clutch)	1