









ASSEMBLY INSTRUCTION

MODEL: 3D-RAVEN D-TABLE

Before you begin, please follow Assembly Instruction carefully. Then follow them step by step.

HARDWARE LIST			
A	JCBC M6 x 40mm		8pcs
B	Hex Nut		16pcs
C	Flat Washer M6		16pcs
D	Spring Washer M8		16pcs
E	Base Adjuster		6pcs
F	CSK M4 x 32mm		16pcs
G	Allen Key		1pc
H	Spanner 12.8mm		1pc

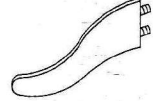
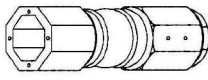
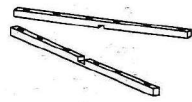
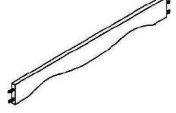
PART LIST					
1	 Table Top	1pc	2	 Pedestal Leg	6pcs
3	 Pedestal	2pcs	4	 Leg Support	4pcs
5	 Stretcher	1pc			

STEP 1

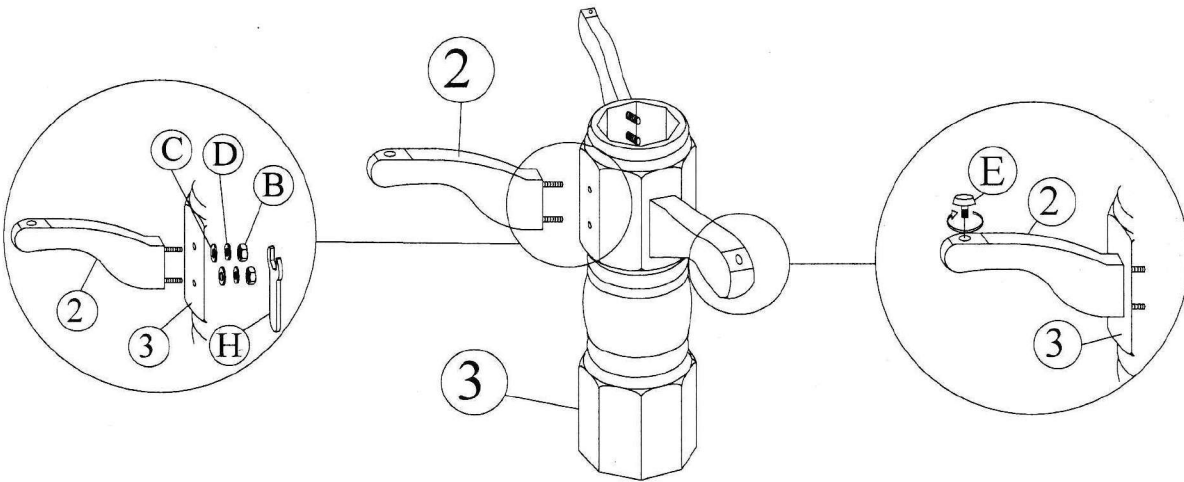

STEP 2

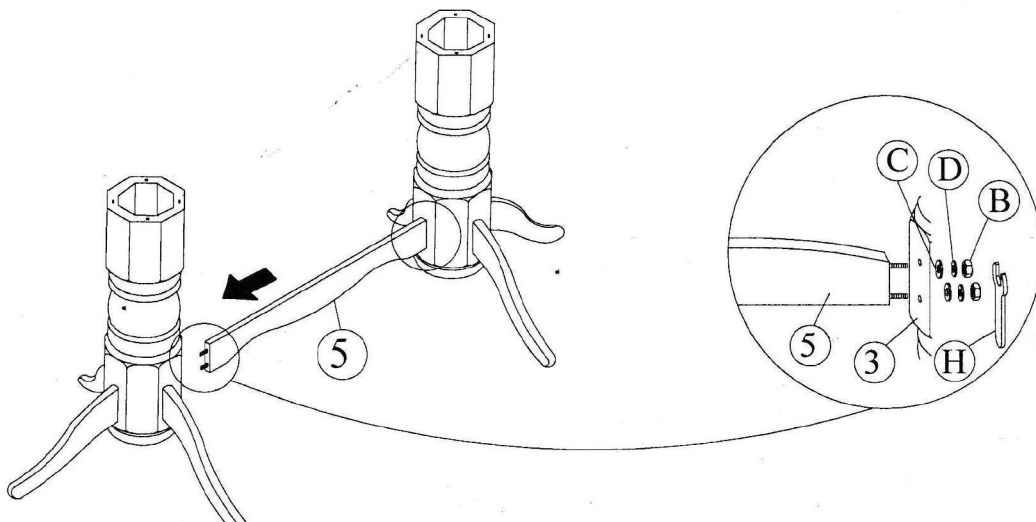

ASSEMBLY INSTRUCTION

MODEL: 3D-RAVEN D-TABLE

Before you begin, please follow Assembly Instruction carefully. Then follow them step by step.

STEP 3

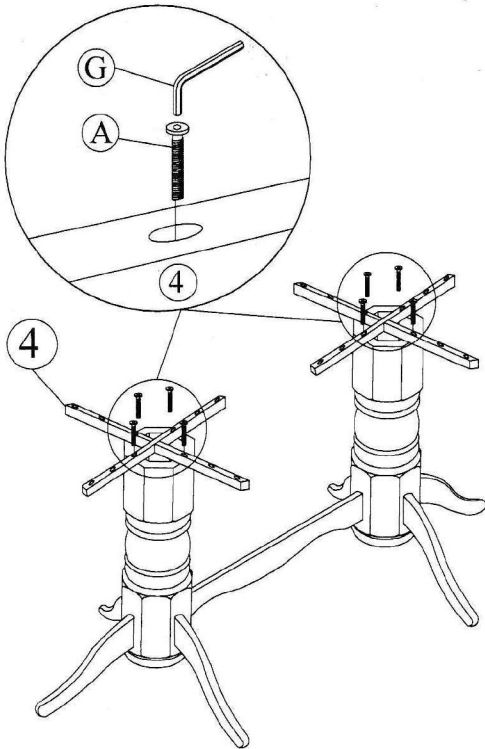

STEP 4

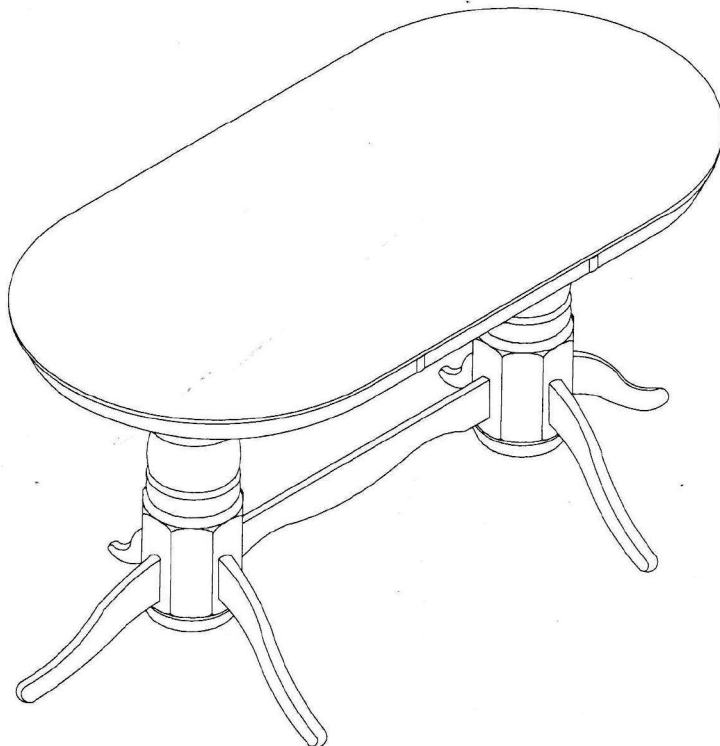
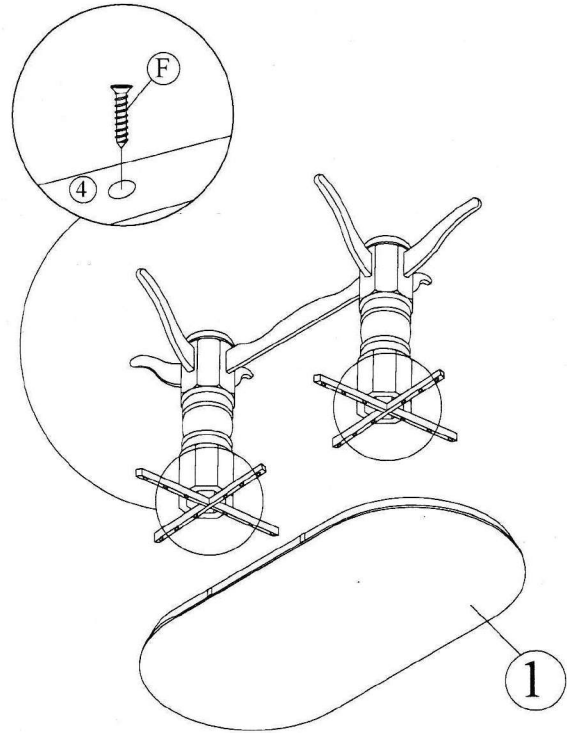

FULLY SET



ASSEMBLY INSTRUCTION

MODEL :3D - RAVEN COCO CHAIR

HARDWARE LIST (2 Pcs)

A	JCBC M6 x 45mm		12pcs
B	Spring Washer M6		12pcs
C	Flat Washer M6		8pcs
D	Wood Dowel M8 x 30mm		8pcs
E	CSK M4 x 32mm		14pcs
F	Allen Key		1pc

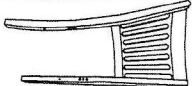
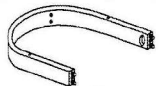
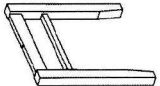
PART LIST (2 Pcs)

1		2pcs	2		2pcs
3		2pcs	4		2pcs
5		2pcs			

STEP 1

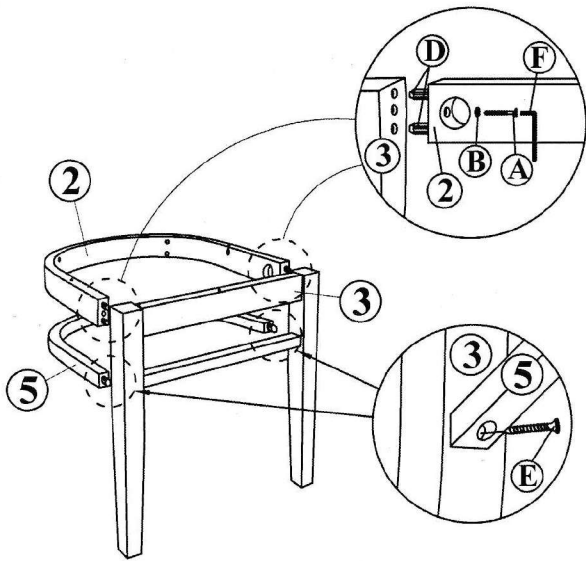

STEP 2

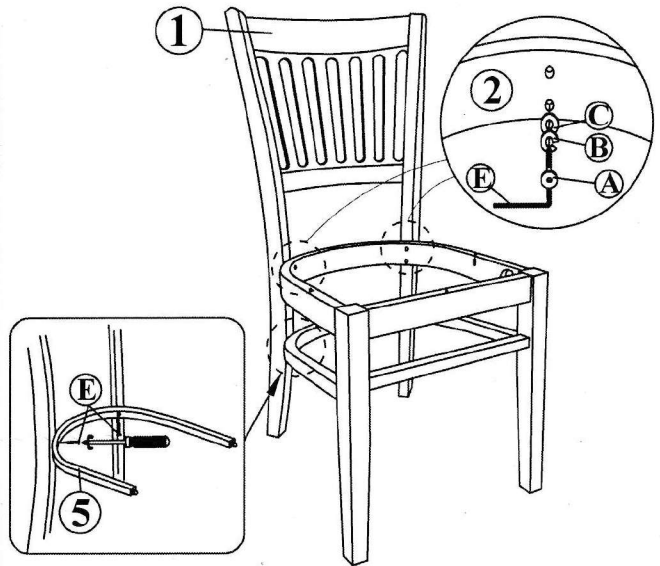

STEP 3

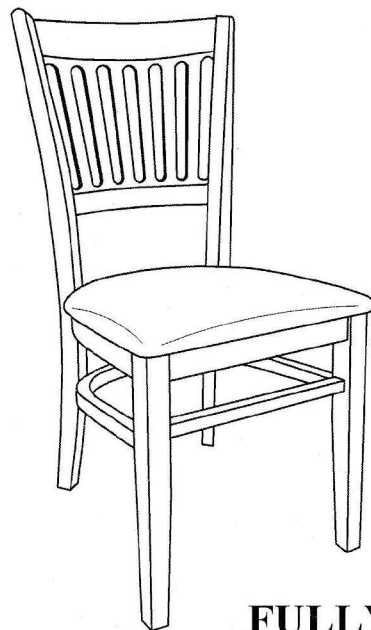
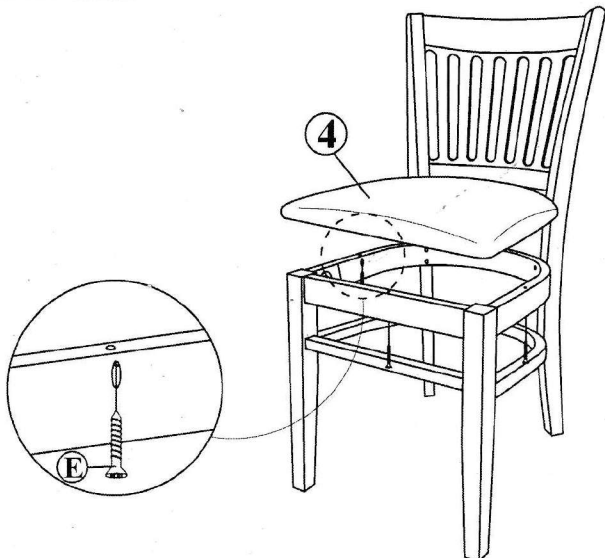

FULLY SET