

NEW!

TEAM FEEDER™

TEAM BALL FEEDER FOR BASEBALL & SOFTBALL

FEEDER



New!
Wireless Remote

Shown as Baseball Feeder

TEAM BALL FEEDER
PATENTS APPLIED FOR

INSTRUCTION MANUAL

OPERATION · SETUP · USE & CARE · SERVICE



SPORTS ATTACK LLC. | 800.717.4251 | www.sportsattack.com

WARRANTY STATEMENT

What is most important to Sports Attack is that your machine meets your expectations and represents our high standards of quality and performance. No matter the circumstances, if this is not the case, we encourage you to call our customer service department at 800.717.4251.

Warranty:

Residential & Institutional

We stand behind the material and workmanship of our machines as well as all wear components (i.e., throwing wheels, controllers, and motors) for a period of two (2) years from the date of original purchase based on the serial number and date codes on the unit.

Commercial

We stand behind the material and workmanship of our machines as well as all wear components (i.e., throwing wheels, controllers, and motors) for a period of one (1) year from the date of original purchase based on the serial number and date codes on the unit.

Requirements of the Warranty

- Warranty wear components such as motors, controllers and wheels may now require a picture or live video when submitting your request.
- The serial number that represents the date of original shipment must be legible on the Product, it cannot be removed or altered in any way.
- All date codes on unit components must be legible, not removed or altered in any way.
- If warranty components have previously been provided by Sports Attack for the unit, video evidence of their use on the machine must be provided when submitting your request.

Not Included in this Warranty:

- Normal wear and tear;
- Cosmetic damage (i.e., minor scratches, surface deformations, or discolorations) including natural fading of colors;
- Damage caused by misuse, abuse, accident or negligence including prolonged exposure to inclement weather;
- Damage caused by fire, flood or any other Act of God;
- Unauthorized modification or alteration of a machine including the use of non-authorized, after market components; and
- Any damage or failure arising after the warranty period.

The Warranty Process

If you encounter any issues during the warranty period, Sports Attack will quickly get your machine back in working order. To submit a warranty request, you must call our customer service department at 800.717.4251. If the warranty repair involves a replacement part, we will make sure you get both the part and easy instructions for replacement at no cost to you.

Returns

Sports Attack manufactures the highest quality sports training equipment in the world. If for any reason you are not satisfied, a machine can be returned within 30 days of receipt, for any reason, for a full refund less a 15% restocking fee. Cost of shipping the unit back to Sports Attack will also be the responsibility of the purchaser. Please note that the refund amount may be reduced by any non-cosmetic damage to the machine.

Please call customer service department at 800.717.4251 for returns.

SHIPPING DAMAGE CLAIMS PROCEDURE

NOTE: For your protection, please note that equipment in this shipment was carefully inspected and packaged by skilled personnel before leaving the factory.

Upon acceptance of this shipment, the transportation company assumes full responsibility for its safe delivery.

IF SHIPMENT ARRIVES DAMAGED:

1. **VISIBLE LOSS OR DAMAGE:** Be certain that any visible loss or damage is noted on the freight bill or express receipt, and that the note of loss or damage is signed by the delivery person.

(cont. on page 1)

To register the Warranty, please return the Warranty Registration Card to:

Sports Attack LLC.
P.O. Box 1529
Verdi, NV 89439

For repairs and service after the Warranty period, please call:

Sports Attack
Customer Service Dept.
Ph 800.717.4251
Fx 775.345.2883

RETURNS

To return an item, please contact our Customer Service Department at 800.717.4251.

A 15% restocking fee will be charged for any items accepted for return. It is the customer's responsibility to handle the repacking and shipment (as well as all associated fees) back to Sports Attack.

No returns will be accepted after 30 days of receiving this product.

2. **FILE CLAIM FOR DAMAGE IMMEDIATELY:** Regardless of the extent of the damage.
3. **CONCEALED LOSS OR DAMAGE:** If damage is unnoticed until the merchandise is unpacked, notify the transportation company or carrier immediately, and file "CONCEALED DAMAGE" claim with them. This must be done within fifteen (15) days from the date the delivery was made to you. Be sure to retain the container for inspection.

Sports Attack LLC. cannot assume liability for damage or loss incurred in transit. We will, however, at your request, supply you with the necessary documents to support your claim.

INTRODUCTION

Thank you for purchasing this Sports Attack LLC. equipment.

Proper assembly, careful operation and consistent maintenance of this equipment will ensure that it gives you the very best performance and a long, economical service life.

This manual contains the information needed to properly set up the Team Ball Feeder, and to use, care for and maintain the Team Ball Feeder, in a manner which will ensure its optimum performance.

RECEIVING THE PRODUCT

Please check the contents of your boxes to ensure you have received all parts for the feeder.

If anything is missing or damaged, call Sports Attack Customer Service at 800-717-4251. If the product or package has been damaged in shipping, note on shipping tag, save all evidence of damage along with related documents and contact the shipper immediately.

See page 5 for Assembly instructions.

TABLE OF CONTENTS

Warranty Statement	i
Team Ball Feeder Safety Instructions	2
Team Ball Feeder Features & Operational Controls	3
Team Ball Feeder Assembly	4-9
Team Ball Feeder Operation	10

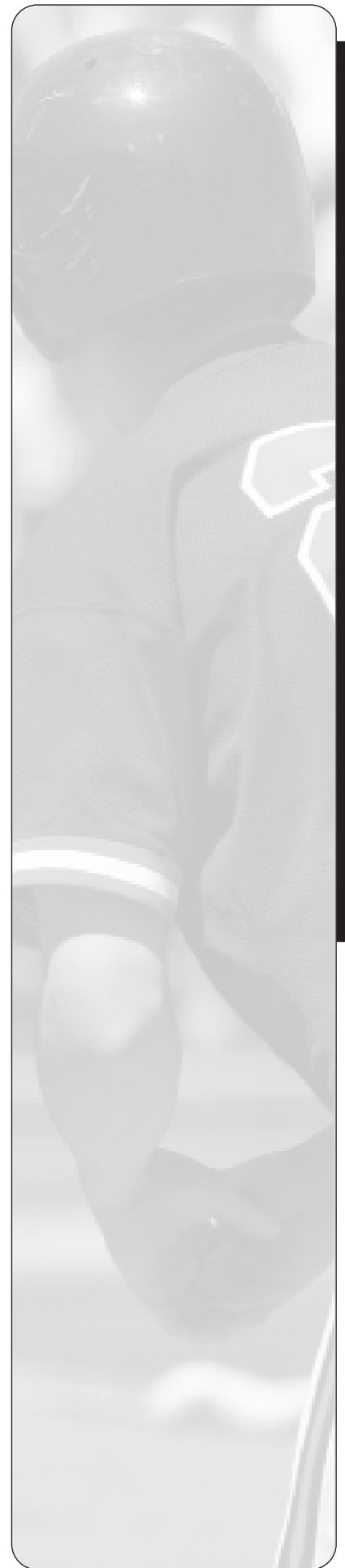

SAFETY INSTRUCTIONS

ELECTRICAL SAFETY

Use a 115 volt single phase 3-wire (2 wire with ground) grounded power source.

Up to 200 ft. from power source, use a minimum #14/3 grounded 3-wire 15 amp minimum rating extension cord.

Over 200 ft. from power source, consult a licensed electrician for required power cord size.

OPERATING SAFETY

CAUTION: Carefully check Team Ball Feeder for completeness and condition before connecting to electrical power:

1. Drive belt must be in alignment with motor pulley.
2. Make sure rear leg is aligned with both front legs (see Fig. 1).
3. Check to make sure the hitter's warning light is on.
4. Never cross home plate when the warning light is "ON".
5. When warning light is "ON," be ready for a pitch.
6. Occasionally the Team Ball Feeder may skip a pitch. Be alert for the following pitch.
7. It is possible that the Team Ball Feeder could skip a pitch at the end of its supply of balls causing the hitter to think the last ball has been delivered. Always be prepared for a pitched ball as long as the light is "ON" and the feeder is in operation.
8. Use protective screen in front of pitching machine. Make sure it is tall enough to also protect the feeder.
9. Test pitches before allowing a hitter to enter the batter's box.

Carefully check the Team Ball Feeder frequently for cleanliness, chips and cracks. Do not use if damaged. (For damage within Warranty period, see Warranty Statement, page i.)

Do not allow anyone to walk in front of the machine if it is connected to electrical power.

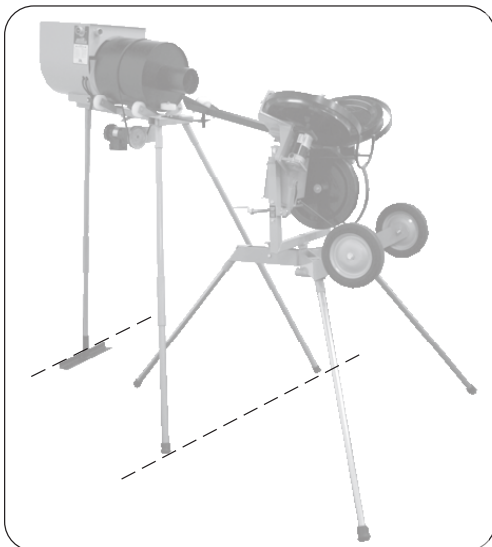

Fig. 1 Rear leg is parallel to the front legs.

WARNING PERSONAL INJURY HAZARD

Carefully read all instructions in this manual, and all labels and warnings on Team Ball Feeder before using this machine.

Use machine only under adult supervision. Failure to operate Team Ball Feeder as described in this manual can result in severe personal injury or death.

ELECTRICAL SHOCK HAZARD

Team Ball Feeder must be connected to a properly grounded electrical receptacle.

Do not operate on wet ground.

CAUTION PERSONAL INJURY HAZARD

DO NOT allow anyone to walk in front of the machine if it is connected to electrical power.

Carefully check Team Ball Feeder for completeness and condition before connecting to electrical power.

At all times when the red warning light is "ON" it is possible a ball will be pitched. Be alert.

EQUIPMENT ELECTRICAL DAMAGE

DO NOT plug in or energize this equipment until all Assembly Instructions (see pages 4-6) and Operation Instructions (see page 7) are read and followed.

FEATURES & OPERATING CONTROLS

TEAM BALL FEEDER PATENTS APPLIED FOR

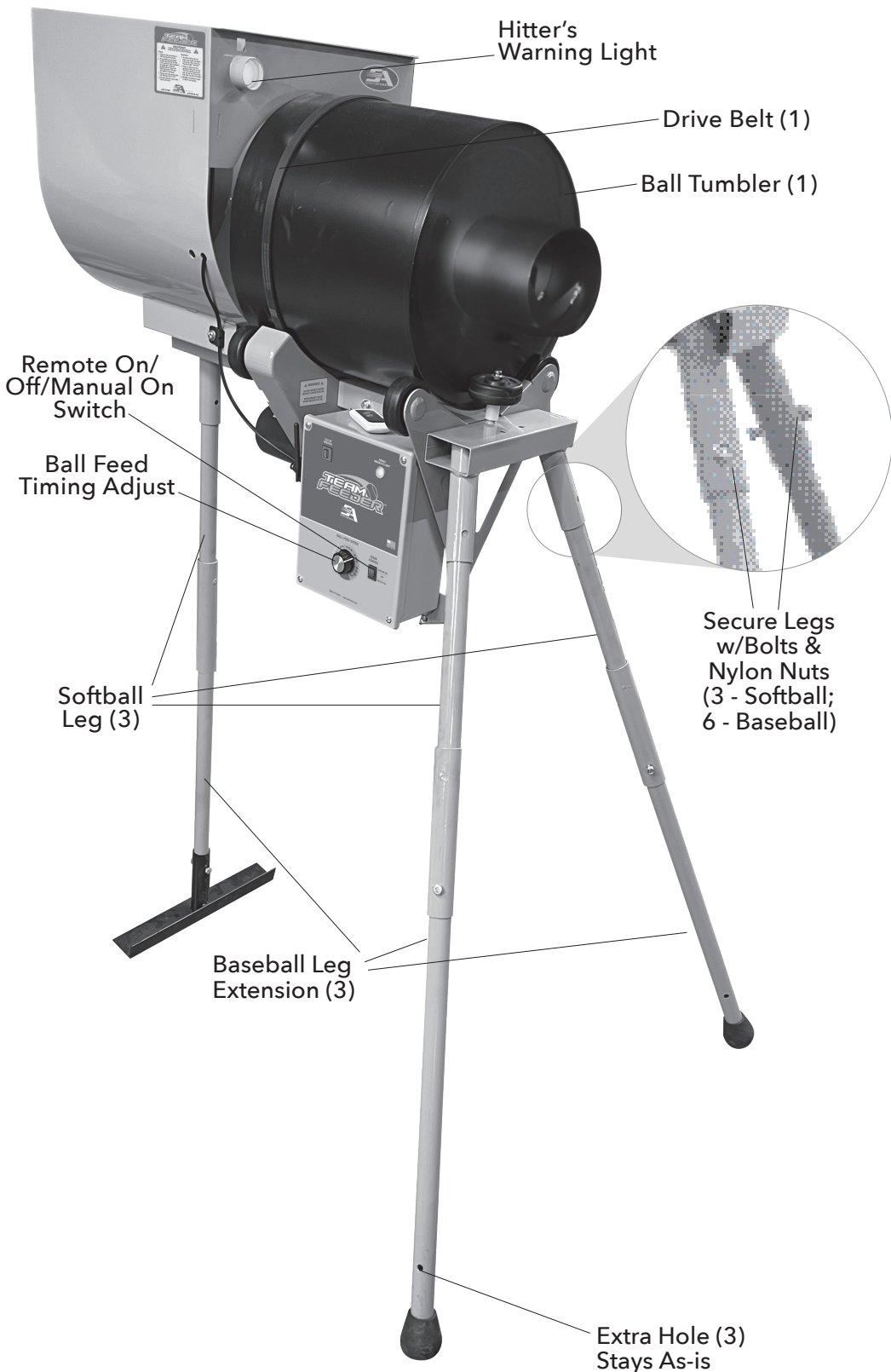

Not Shown:

- Ball Feed Chute (1)
- Feed Trough (1)
- Manual

INCLUDED MATERIALS

Baseball

Qty	Item
6	$\frac{5}{16}$ " x 2" Bolts
6	$\frac{5}{16}$ " Nylon Nuts

Softball

Qty	Item
3	$\frac{5}{16}$ " x 2" Bolts
3	$\frac{5}{16}$ " Nylon Nuts

TOOLS REQUIRED

Qty	Item
2	$\frac{1}{2}$ " Wrenches or wrench and socket-ratchet combo.

For missing parts, please call:

Sports Attack
 Customer Service Dept.
 Ph 800-717-4251
 Fx (775) 345-2883

TEAM BALL FEEDER

TEAM BALL FEEDER ASSEMBLY

Your Team Feeder will arrive fully assembled and strapped to pallet.

1. Remove straps from the machine
2. Team Feeder is shipped with shipping legs (see Fig. 3). These will need to be removed and discarded. Install the actual machine legs.
5. Remove ball feed chute from pitching machine and install feed chute supplied with the Team Ball Feeder.
6. Assemble ball feed trough. See page 6.



Figure 3 Team Feeder with shipping legs on pallet

CAUTION PERSONAL INJURY HAZARD

Use of the softball feeder on a machine set up for baseball could result in equipment damage and/or personal injury.

TEAM BALL FEEDER ASSEMBLY (cont'd)

- Align ball feed trough and Team Ball Feeder to pitching machine. See Figures 5a through 5c. When aligning the Team Ball Feeder, ball feed trough and pitching machine, make sure the hitter's warning light will be visible to the batter while they are practicing.



Figure 5a Align ball feed trough under Team Ball Feeder.



Figure 5b Align ball feed trough from Team Ball Feeder to pitching machine (Side View).

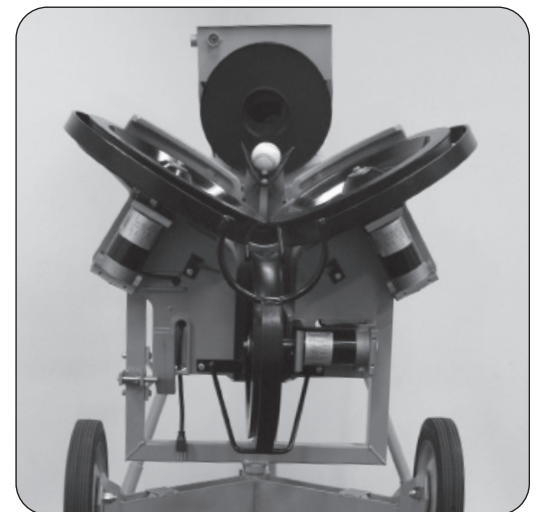

Figure 5c Align ball feed trough from Team Ball Feeder to pitching machine (Front View).

NOTE: The Team Feeder is supplied with one (1) ball feed chute.

CAUTION PERSONAL INJURY HAZARD

Use of the softball feeder on a machine set up for baseball could result in equipment damage and/or personal injury.

Team Ball Feeder Assembly

TEAM BALL FEEDER BALL TRAY ASSEMBLY

Installing the ball tray assembly for the Team Feeder on the Hack Attack and Junior Hack Attack Baseball and Softball Pitching Machines.

MATERIAL

1. Taking the bracket and the two (2) mounting bolts (See Figure 6), select the proper alignment holes on the bracket for baseball or softball (See Figure 7).

IMPORTANT Make sure the bracket is attached with the rubber tube facing **up** (See Figure 8 on page 8).

2. Using the ½ inch wrenches or ratchet, attach the bracket to the team feeder (See Figure 6 below). The Team Feeder is now ready to attach to your pitching machine.
3. Line the team feeder up directly behind the pitching machine, leaving enough space between the chute and the bracket to allow for the tray that will carry the balls to the machine.
4. Attach the flexible stem socket to the flexible stem (See Figure 8), being sure the flexible stem inserts fully into the flexible stem socket.

The ball tray assembly is now fully assembled and ready to use.



Figure 6 Attaching bracket.

INCLUDED MATERIALS

Qty	Item
1	Bracket with Flexible Stem
2	5/16" x 2 1/4" Mounting Bolts
1	Tray
2	5/16" USS Washer
1	5/16" Nylon Lock Nut
1	Mounting Bracket (ball tray to feeder)

TOOLS REQUIRED

Qty	Item
2	½" Wrenches or wrench

To order additional parts, please contact:

Sports Attack
Customer Service Dept.
Ph 800.717.4251
Fx 775.345-2883

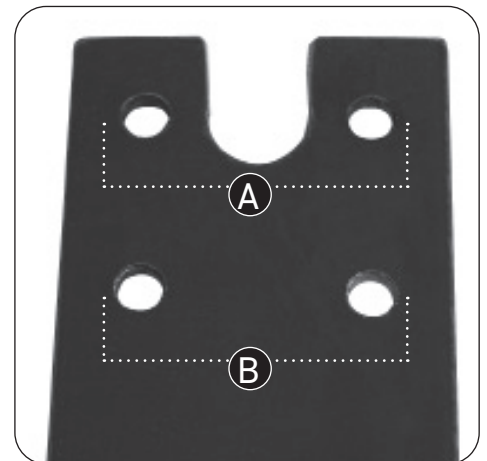

Figure 7 Alignment selection

- A** Softball
- B** Baseball

TEAM BALL FEEDER BALL TRAY ASSEMBLY (cont'd)

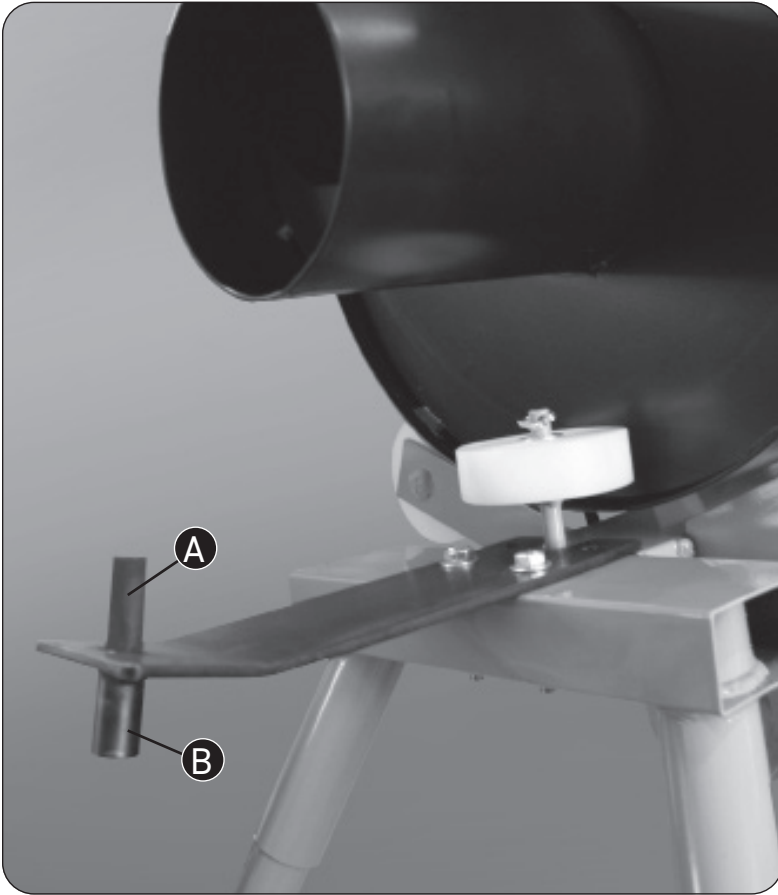

Figure 8 Team Ball Feeder and bracket.

- A** Rubber tube should be facing up.
- B** Metal tube should be facing down.



Figure 9 Ball tray assembly at pitching machine with mounting bracket (ball tray to feeder) installed.

**To order additional parts,
please contact:**

Sports Attack
Customer Service Dept.
Ph 800.717.4251
Fx 775.345.2883

Team Ball Feeder Ball Tray Assembly

TEAM BALL FEEDER OPERATION

REMOTE ON/OFF/MANUAL ON SWITCH

1. This switch starts and stops the Team Ball Feeder, which also turns the warning light "ON" and "OFF."
2. Have pitching machine turned on with the wheels turning fast enough to deliver a ball so that the first ball from the feeder does not jam in the pitching machine.
3. **NEW 3-POSITION POWER SWITCH**
Turning the switch to "Remote On" allows you to turn the feeder "ON" and "OFF" using the remote only. Turning the switch to "Manual On" turns power on and disables remote access. The "Power" light and the "Safety Warning Light" (facing hitter) indicate the feeder power is "ON" and the unit is dispensing balls.

HITTER'S SAFETY WARNING LIGHT

1. Any time the hitter's safety warning light is on or the Team Ball Feeder is turning, a pitch could be delivered.
2. Care must be taken as the Team Ball Feeder might skip a pitch or deliver a pitch after skipping a pitch near the end of the supply of balls, causing it to appear that no more balls remain to be pitched. One or more balls may have been so distributed in the Team Ball Feeder that a pitch is skipped, causing the hitter to think that the Team Ball Feeder is empty. Be ready at all times.

GENERAL OPERATION

1. Do not mix different types of balls.
2. ALWAYS use protective screen to protect Team Feeder from batted balls and line drives or void warranty.

CAUTION PERSONAL INJURY HAZARD

Team Ball Feeder should be used under adult supervision only! The on/off switch is intentionally located out of reach of children.

•
Use of the softball feeder on a machine set up for baseball could result in equipment damage and/or personal injury.

•
Any time the hitter's warning light is "ON" or the Team Ball Feeder is turning, a pitch may be delivered.

Be alert at all times.