



# Lake Erie Toolworks

## Shoulder Vise Screw Installation Instructions

Copyright, Lake Erie Toolworks, Inc. – Version 3/14/2019

[www.LakeErieToolworks.com](http://www.LakeErieToolworks.com)

### Very Important – Please Read!

Read all instructions prior to vise screw kit installation to ensure full knowledge of the installation process. Also, please follow all proper safety rules and guidelines as appropriate when using your woodworking tools to install the vise screw kits in order to prevent any bodily injury.

Shoulder Vise Kit Contents:	
Quantity	Description
1	Shoulder Vise Screw
1	Extended Vise Nut (or optional Standard Vise Nut which requires build-up) <b>Note:</b> If using Standard Nut, refer to Wagon Vise install guide for Nut build-up info
1	Brass Mounting Plate with Shoulder Bolt Anchor, Screws & Slotted Shim
1	Vise Handle with End Caps & O-Rings

Recommended Installation Tools and Additional Hardware:	
Quantity	Description
1	1-1/4" dia. Forstner drill bit (clearance hole can be up to 1-1/2" dia.)
1	9/16" drill bit
1	Pilot hole drill for #14 screw (based on wood species)
1	Deadblow mallet or wooden mallet
Additional Hardware	
1	1/2" threaded rod (see "User Supplied Dimensions" for length)
2	1/2" washers
2	1/2" nuts to match threaded rod
<b>(Note: M12 hardware can be substituted)</b>	
2	1/2" x 6" lag bolts (Qty.4 if Extended Nut block & Endcap will be bolted together)

**Disclaimer: Woodworking is inherently dangerous and Lake Erie Toolworks cannot be held responsible for any injury to person or property arising from installation, use or misuse of our products.**

# Instructions for Installing Shoulder Vise Screws

## **Preface / Reference**

If you haven't started building your bench yet, there are several great books out there that can give you good guiding principles about what type of bench and vises will suit you best. If you already have a bench, chances are strong that you can retrofit and accommodate a vise of your choice.

We recommend reading the following books:

- Christopher Schwarz's The Workbench Design Book, The Art & Philosophy of Building Better Benches. He offers a great overview of different types of vises and their usefulness as well as a couple of great plans based on historical designs, all of which can use our various vise screws.
- Scott Landis's The Workbench Book is another very good workbench resource.
- Lon Schleining's The Workbench, a Complete Guide to Creating Your Perfect Bench can also provide you with some good information to help guide your overall bench building efforts.

The books mentioned above will get you thinking about the type of work that you do or plan to do and what type of bench and vise combinations will work best for you.

## **Instruction Steps**

- Read all instructions first and carefully layout and check your work before actually drilling or cutting. It's easy to back yourself into a corner with clearance issues if you're not careful. It's also pretty tough to un-drill holes or un-saw a bench part once you've done it.
- We recommend that you review the "User Supplied Dimensions" and fully document all of the requested dimensions to be used as a reference for completing your work bench shoulder vise screw installation.

### **User Supplied Dimensions**

Dimension A: Length of Shoulder Vise Screw extension past Extended Nut Block	
Dimension B: Length of Shoulder Vise Block = Dimension A + 1.5"	
Dimension C = Width of Benchtop	
Dimension D: Length of Endcap = Dimension C + Dimension B	
Dimension E (Distance from front of Endcap to bolt holes): Dimension B + 2"	
Dimension F (Threaded Rod Length) = Dimension B + Width of Benchtop + 3" + thickness of 2 Nuts and 2 Washers	

## Shoulder Vise Installation Instructions

### Finishing Shoulder Vise Screw

If you plan to stain your wood vise screw kit, it is important that you do so prior to applying any final finishing product.

For the threaded section of the screw we advise that you use a penetrating oil or oil-varnish mix such as what you might finish your workbench with. We don't recommend any finish that will build up a film, such as polyurethane. A good option would be to use an oil finish such as "Watco Danish Oil", "Mahoney's Walnut Oil" or "Defoil".

The vise screw hub can be completed with whatever finish that you find appropriate.

After final finishing, we also recommend that you wax your vise screw and internal nut thread with a good quality wax of some sort (paraffin, beeswax or paste wax) to allow smooth and easy functionality. A nylon brush can be helpful when putting wax on the threads of the nut.

### Extended Nut Block

Thread the Vise Screw all of the way into the Extended Nut Block with counterbore facing hub of screw (front of bench). Back off by 1/4 of a turn. Measure length of threaded portion that sticks out past the Extended Nut Block and record in "**User Supplied Dimensions**" chart as **Dimension 'A'** (Length of Shoulder Vise Screw Extension past Extended Nut Block). (See Figure 1)

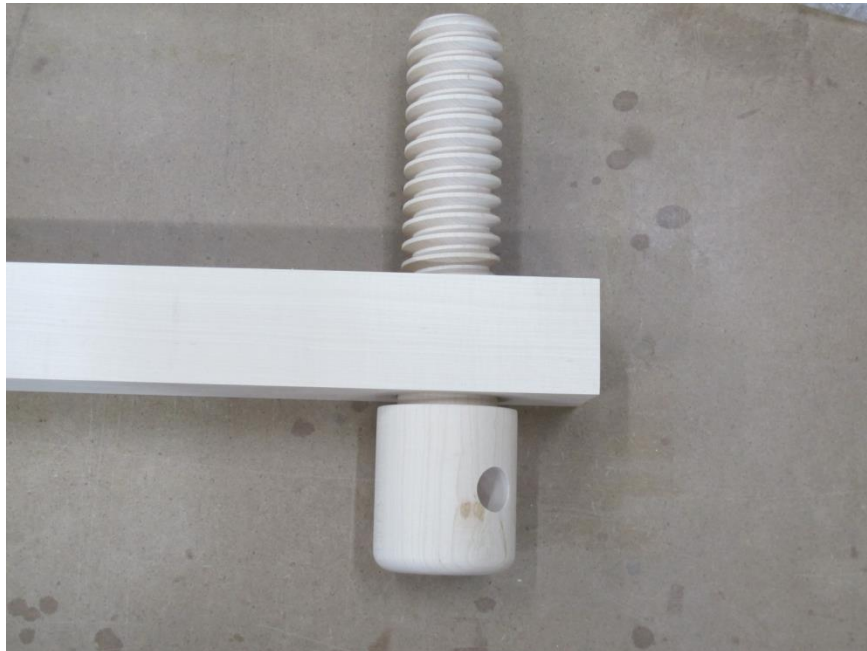

(Figure 1)

Determine and record **Dimension 'B'** by following the instructions in the "**User Supplied Dimensions**" chart.

Then you will use a square to mark both sides of the vise on the Extended Nut Block as shown (See Figures 2 & 3). You may have to use a small scrap of wood to register off of the top of the threads if the thin edge of your square goes between the crests (top) of the threads.



(Figure 2)



(Figure 3)

Remove the vise and measure the distance between the two parallel lines that you just marked on the nut. Make another parallel line at exactly halfway between the first two lines. (See Figure 4)

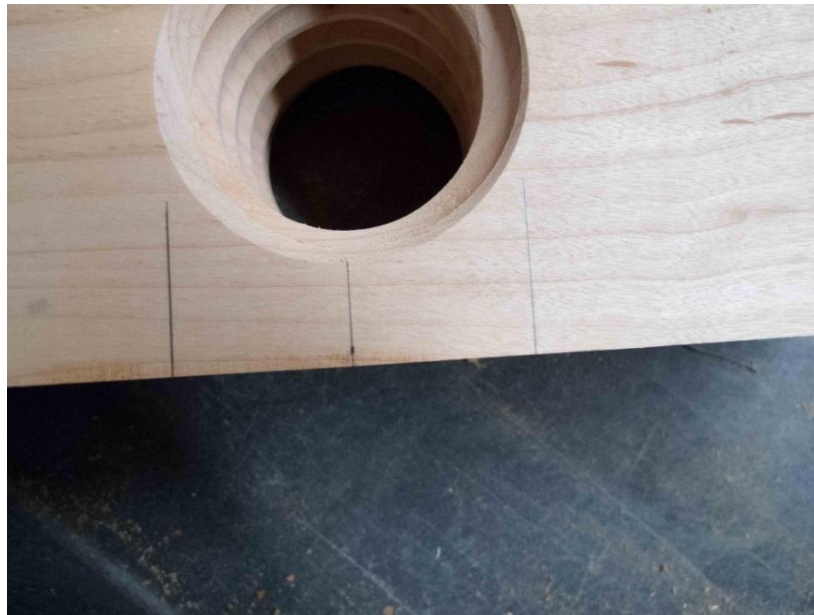

(Figure 4)

Next, drill a 9/16" diameter hole in the Extended Nut Block using the drawing as a guide. (See Figure 5)

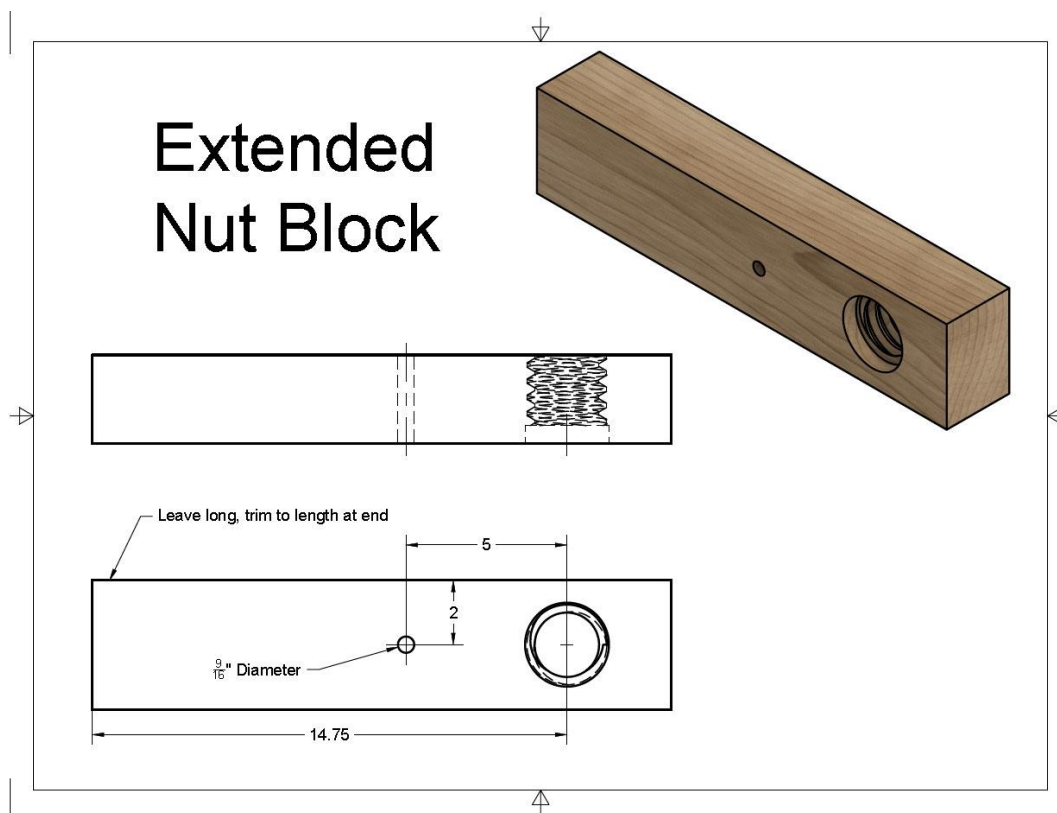

(Figure 5)

## Bench Anchor Installation

Wagon and Shoulder vise brass mounting plates are now shipped with a self-lubricating plastic bushing. The bushing is an Iglus iglide G300 series optimized for long wear and dusty environments. This reduces friction and eliminates the metal on metal contact between the shoulder bolt and the brass mounting plate, which reduces any 'clunking' noise that may occur during use.

Also, the Veritas Bench Anchor is shipped uninstalled and is to be installed by the vise owner via the following instructions. A .020" stainless steel slotted shim is also included to facilitate this as well as resetting the Bench Anchor if it ever shifts during use.

Needed items:

- Shoulder bolt (included in kit)
- Stainless steel slotted shim (included in kit)
- Wagon or Shoulder Vise Screw (included in kit)
- Brass mounting plate (included in kit)
- Veritas Bench Anchor and allen wrench (included in kit)
- Deadblow mallet or wooden mallet (user supplied)

First, you will want to wipe your Bench anchor with a paper towel to remove any oils. The Bench Anchor works by having two separate wedge-shaped parts pulled together by a screw, which in turn expands into the hole that the Bench anchor is inserted into.

You will want to look at the bench anchor and make a visible mark on the ½-13" tapped end so that you will know which face is pushing against the vise hole when it is installed. (See Figure 6 for clarification)

The two faces that push against the hole should be oriented so that they push against the flat sawn surfaces of the hole in the vise. Wood expands and contracts about twice as much in the tangential direction as in the radial direction (flatsawn boards move more in their width with humidity changes than quartersawn boards do). (See Figure 7 for clarification)



(Figure 6)

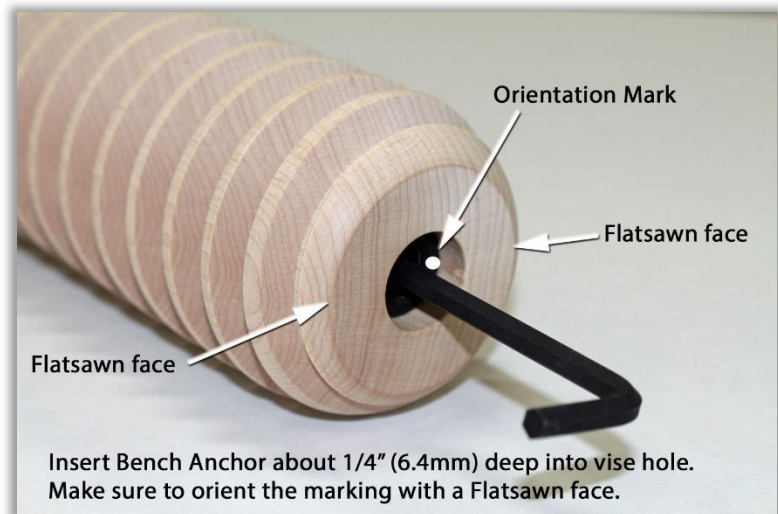

(Figure 7)

Use the allen wrench to loosen the bolt inside of the Bench Anchor (see *Bench Anchor instructions included with your kit*). Insert the anchor until it is about ¼” below the end of the vise and orient your mark so that it is aligned with a flatsawn face of the vise, such as the top of the arch in the maples grain, and lightly snug the bench anchor. (See Figure 7)

Then, insert the shoulder bolt through the back of the brass mounting plate and tighten it by hand into the thread of the Bench Anchor. Put the .020” stainless steel shim between the vise and the brass mounting plate. (See Figure 8)

Then, take your dead blow mallet and while holding the vise with one hand, tap the shoulder bolt until it pushes the whole assembly into the vise and the shim can no longer be moved. Then, loosen the shoulder bolt, remove the brass mounting plate and the shim and then use the allen wrench to lightly snug up the Bench Anchor. It doesn’t take much torque to get plenty of holding force from the Bench Anchor.

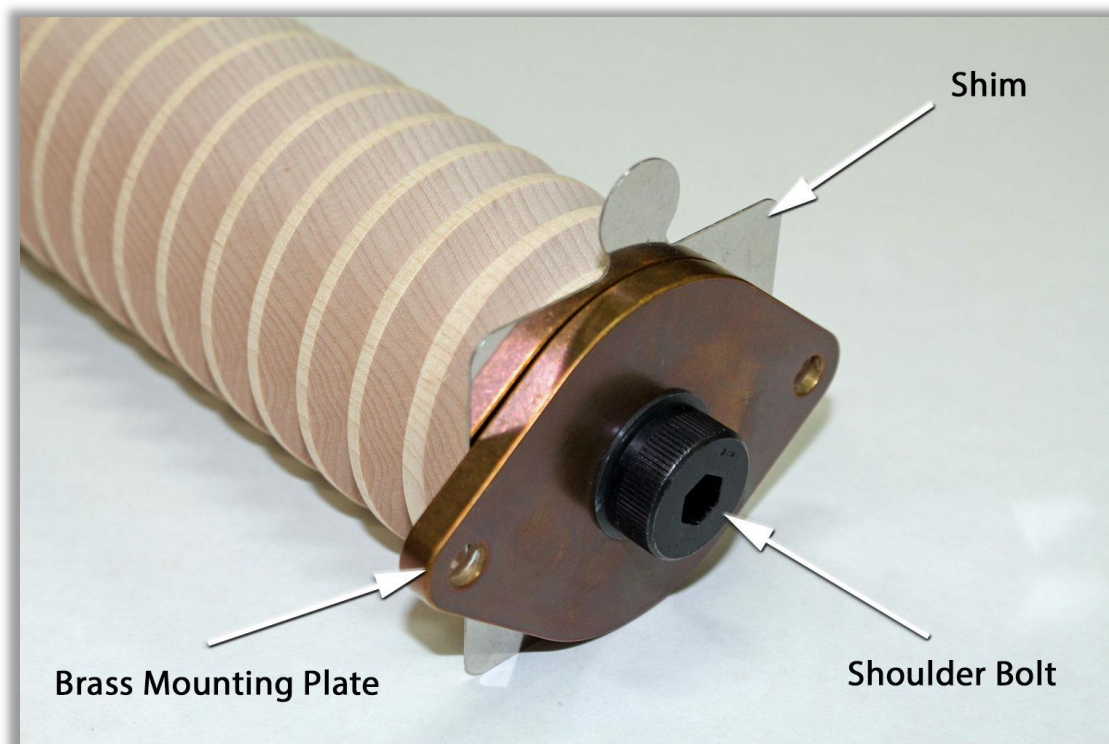

(Figure 8)

## Shoulder Vise Block

Mill a block of wood following the dimensions from the Shoulder Vise Block drawing (See Figure 9) and "User Supplied Drawing" reference information. Drill a 9/16" hole through the block (you may have to drill from both sides) as shown.

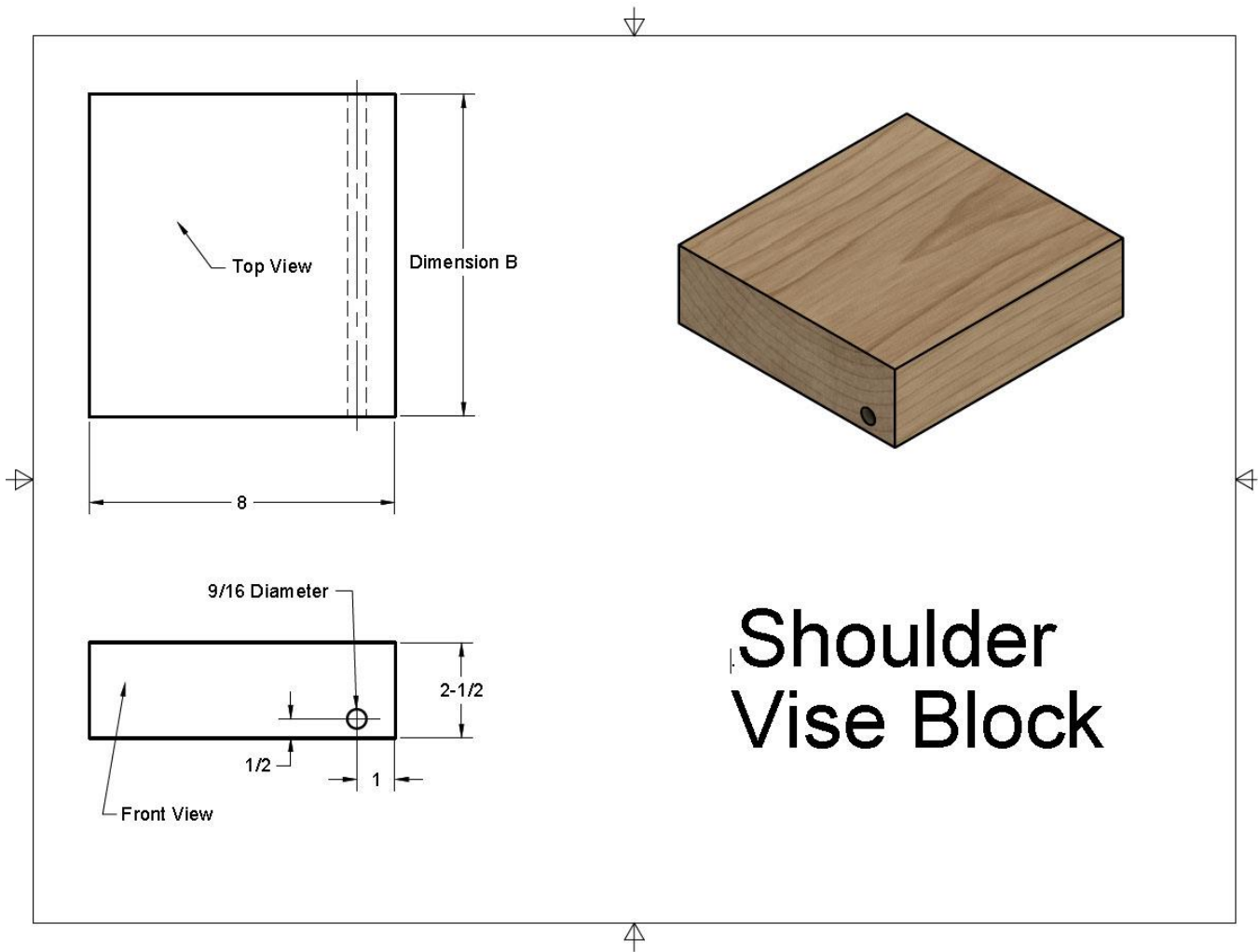

(Figure 9)



## Endcap

Determine the width of your benchtop and enter it in the **"User Supplied Dimensions"** reference section. Determine the length of your endcap and mill out a piece of wood to that dimension. The drawing assumes a bolted butt joint but if you intend to join the Endcap and Extended Nut another way (box joint, dovetail joint, etc.) you will have to make the Endcap longer to allow for the joinery. Drill clearance holes for bolts. (See Figure 10 for details)

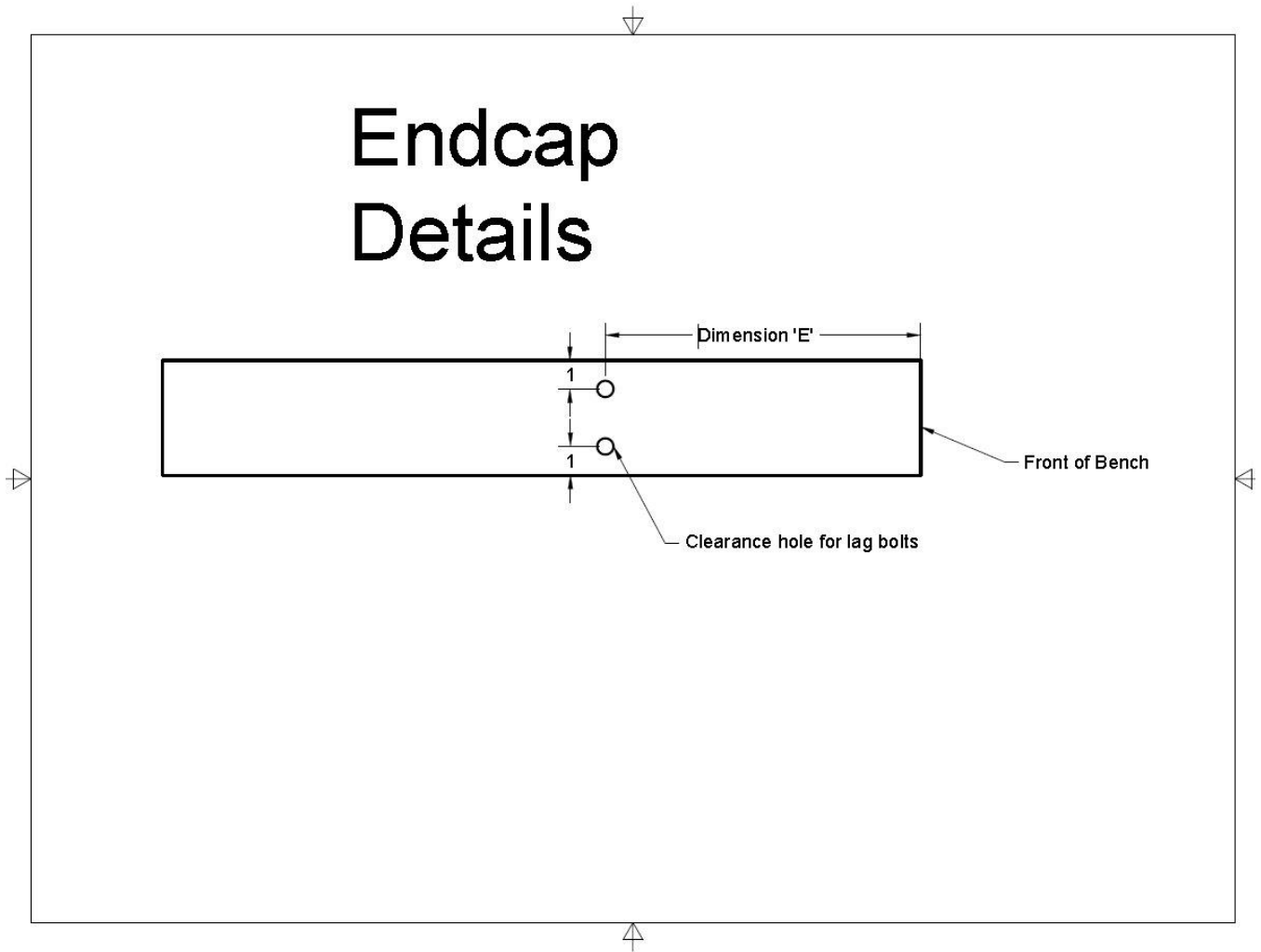

(Figure 10)

## Benchtop

You will need to drill 9/16" diameter holes through each laminated board that is to be glued up into the Benchtop. Use the "Benchtop Detail" drawing for dimensions. This will allow the threaded rod to extend through the entire Benchtop, Shoulder Vise Block and Extended Nut Block. (See Figure 11)

If you already have a benchtop glued up, you will have to drill the 9/16" hole as deep as your drill will allow and will need to cut a slot from the bottom of the bench to hold a washer and a nut so that it intersects with the hole drilled.

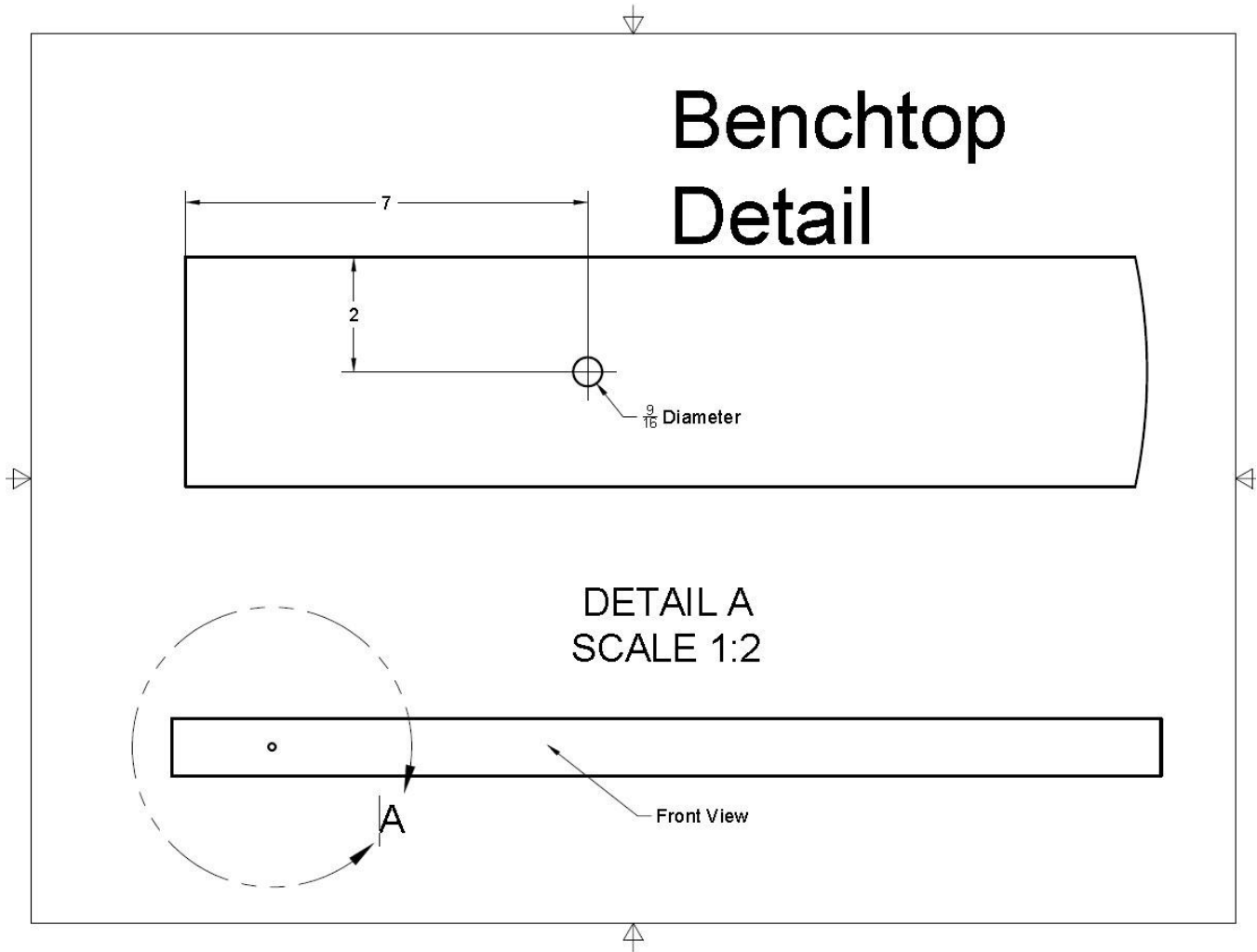

(Figure 11)

## Shoulder Vise Assembly / Installation

Splines should be used between the Shoulder Vise Block, Extended Nut Block, Endcap and Benchtop so that the vise stays in alignment. Cut the slots for the splines (1/2" thick splines are sufficient, plywood works well and is strong/stable), centered 1-1/4" below the top of the Benchtop.

Assemble the Extended Nut Block, Endcap, Shoulder Vise Block and Benchtop with the threaded rod.

Put a washer on the threaded rod, thread a nut onto the end and put the free end through the Extended Nut Block, Shoulder Vise Block and Benchtop. Thread the washer and nut onto the back end of the threaded rod.

If you plan to join the Extended Nut Block and Endcap in another way, do that now. Two Lag bolts work for butt joining the Extended Nut Block and Endcap. Two lag bolts will also be used to bolt the Endcap to the Benchtop. (See Figure 12 for component orientation)

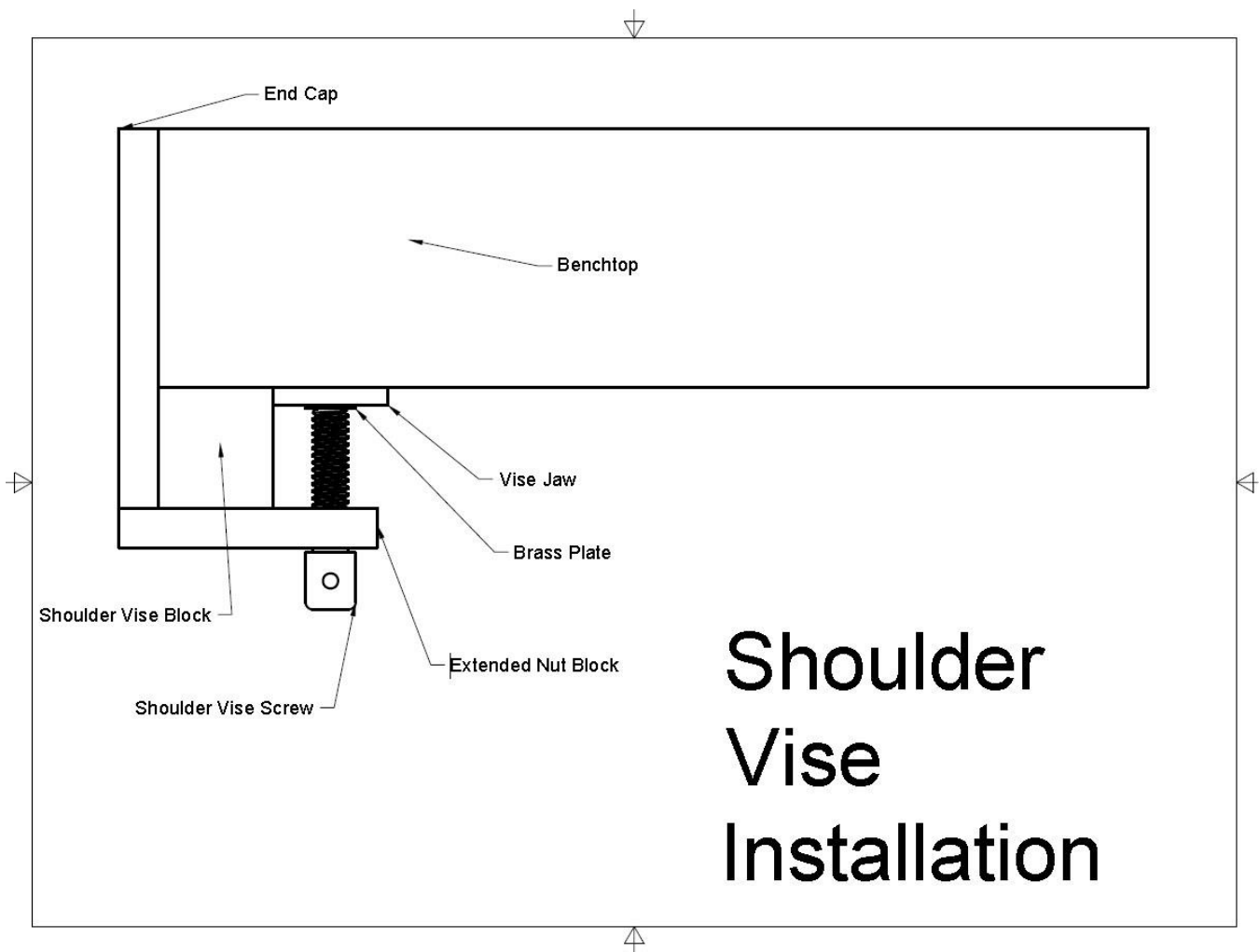

(Figure 12)

## Vise Jaw

Mill the Vise Jaw to the dimensions in the 'Shoulder Vise Jaw' drawing (See Figure 13). Leave an extra  $1/16$ " on the top of the jaw so that it can be planed flush once everything is assembled (this is reflected in the drawing). You will want a close but sliding fit between the Shoulder Vise Block and Trestle. If this becomes too loose the vise will bind in use.

Drill the clearance hole for the bolt that sticks out of the end of the Shoulder Vise Screw.

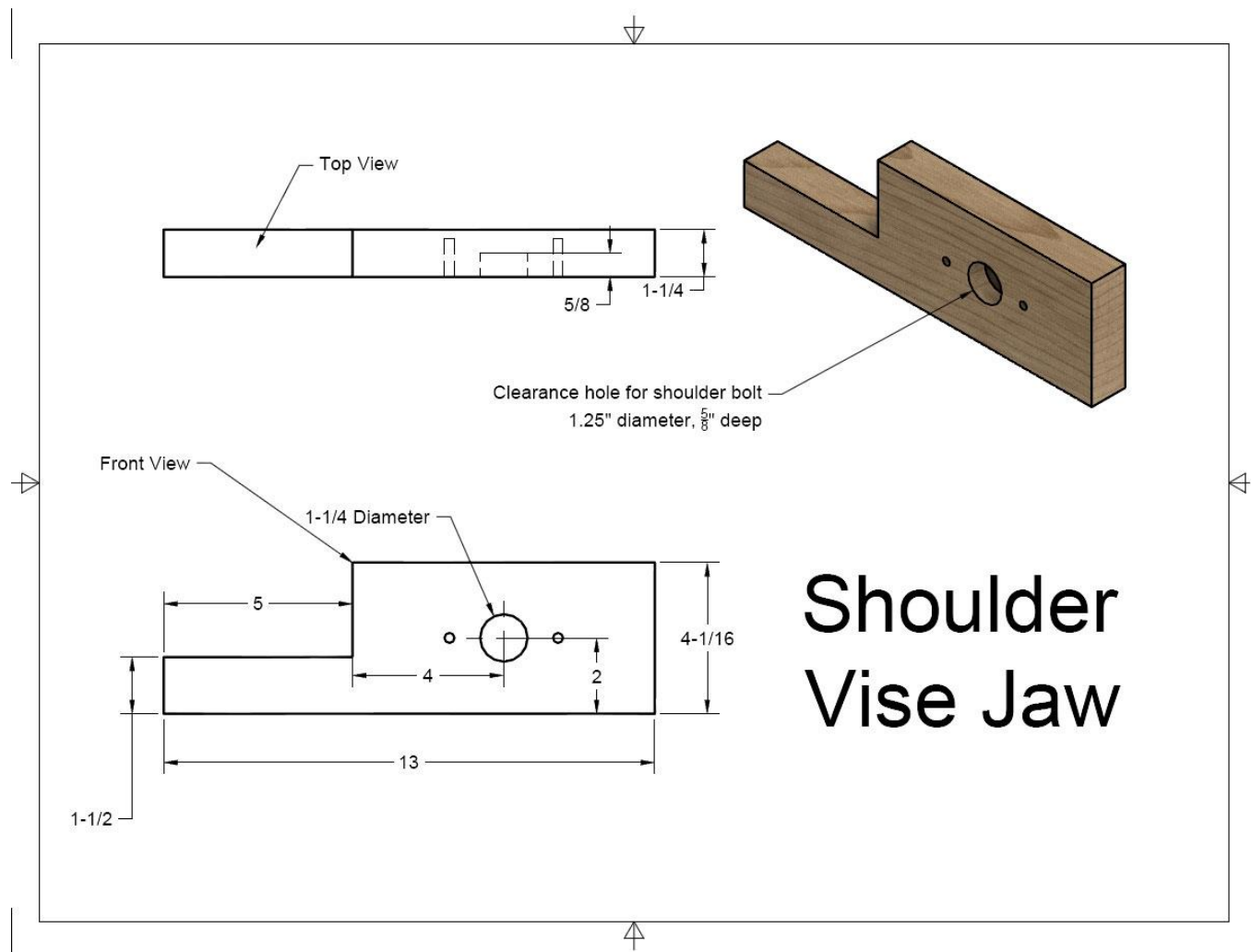

(Figure 13)

## Trestle

In order to constrain the vise jaw, shoulder vises require a board that runs below the Shoulder Vise block, from the front of the Extended Nut to the back of the Benchtop.

This is typically the top of a trestle leg assembly (a top and bottom rail, typically 4" wide by 2-3" thick and 2 or 3 vertical posts between them). The right side of the trestle will be installed plumb with the right side of the Shoulder Vise Block. The top of the trestle can be seen in the Shoulder Vise Overview Drawing (See Figure 14). This is commonly bolted to the Extended Nut block and the Benchtop from below.

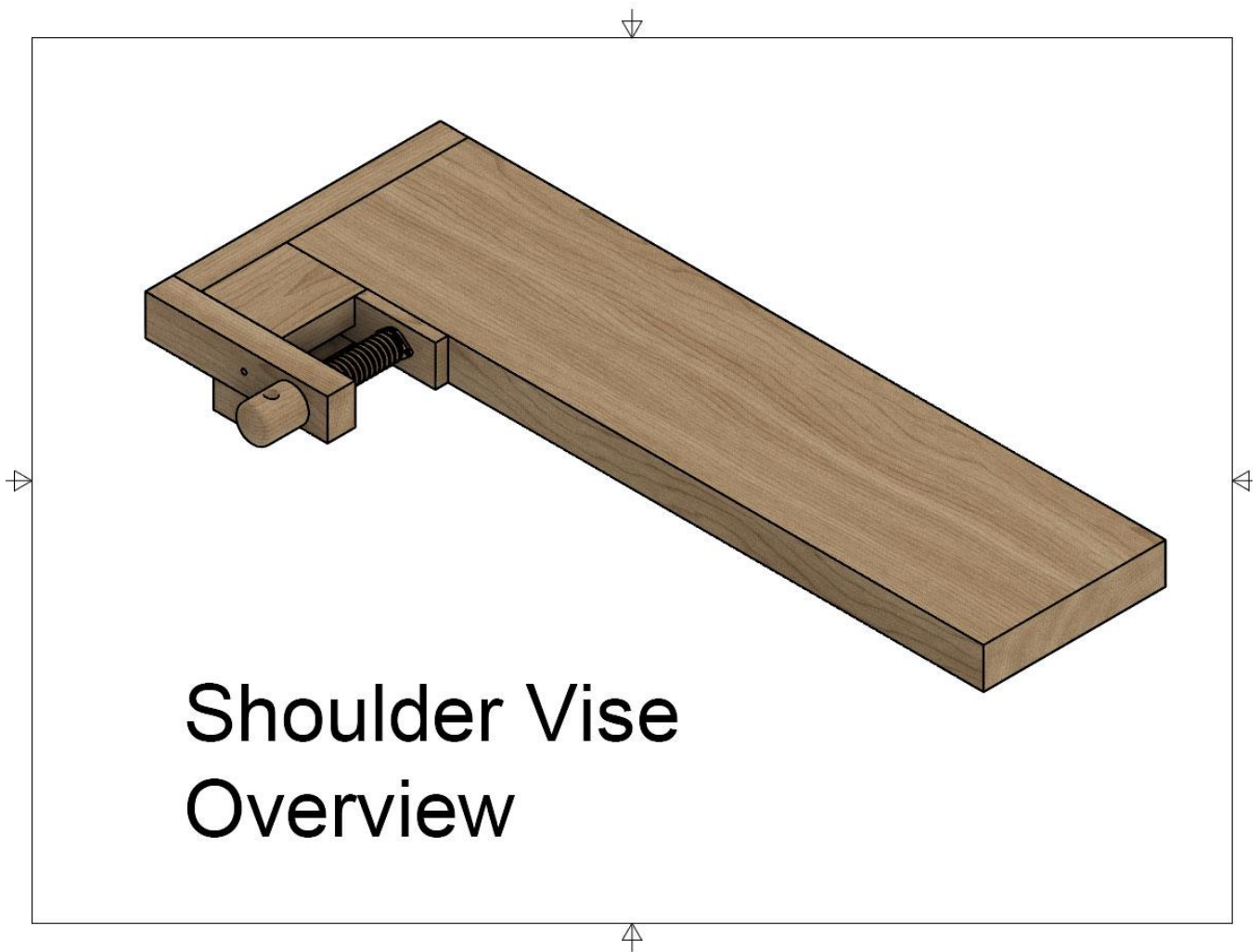

(Figure 14)

## Brass Plate Mounting

Remove the shoulder bolt from the end of the Shoulder Vise Screw assembly and thread the shoulder vise screw into the Extended Nut Block.

Reinstall the brass plate with the shoulder bolt onto the end of the shoulder vise screw.

Put the Vise Jaw into its place and clamp it and then tighten the vise until the brass plate bottoms out on the Vise Jaw and back off until you are able to shift the brass plate around.

Orient the brass plate so that the holes are level with one another, one on the left and one on the right and then push the brass plate up, hold in position and use a pencil to mark the inside of the holes.

Repeat the process, only pushing the brass plate down. Again, repeat the process for the left side and the right side. You will have four overlapping holes on each side and you will need to make a mark in the center of these four holes. Next, drill pilot holes for the #14 screws used to hold the brass plate at these marks. Drive in the #14 screws (wax helps).

Install the vise handle and your vise is now ready to use.

-----

We truly hope that you enjoy your wood shoulder vise screw kit from Lake Erie Toolworks and if you have any questions or comments regarding the installation method detailed in this document or if you have other installation ideas to share, please feel free to contact us via direct email at [info@LakeErieToolworks.com](mailto:info@LakeErieToolworks.com).

We also wish you the absolute best on your woodworking projects and don't forget to drop us a line or send us some pictures on how your shoulder vise screw & work bench efforts turned out. We'd be happy to add them to our website for the benefit of other woodworkers around the globe who are building their workbenches.

Best regards and happy woodworking,

Nick Dombrowski

Lake Erie Toolworks