



Scan for full manual

RTBUS-4C Quick Start Guide

This guide helps you install and use your RTBUS-4C for the first time.

Go to www.kramerav.com/downloads/RTBUS-4C to download the latest user manual and check if firmware upgrades are available.

Step 1: Check what's in the box

- ✓ 1 RTBUS-4C Round Table Mount
Cable Pass-Through
 - ✓ 1 Quick start guide
- ✓ 4 Cable bushings
- ✓ 1 Locking screw for locking ring

Step 2: Get to know your RTBUS-4C

#	Feature
1	Enclosure
2	Locking Ring
3	Inner Plate
4	Cable Slot
5	Inner Plate Screws (4)
6	Cable Bushings

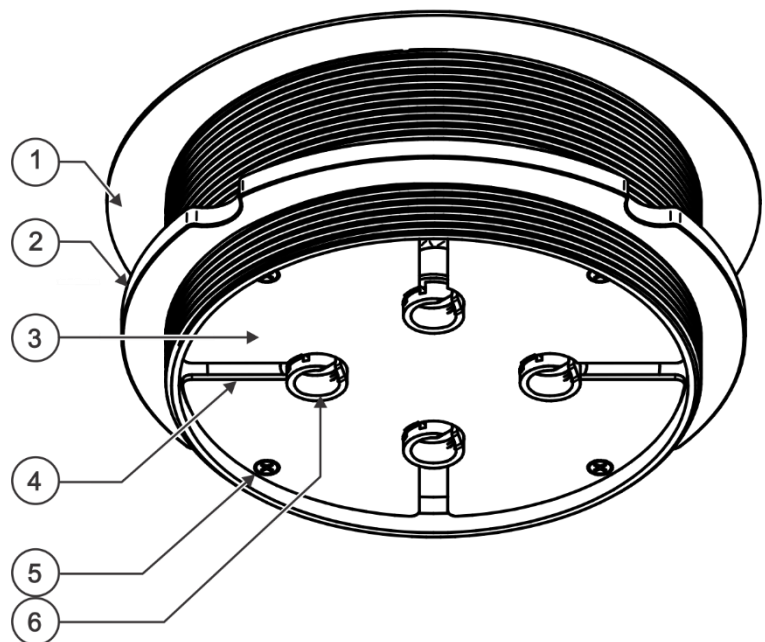
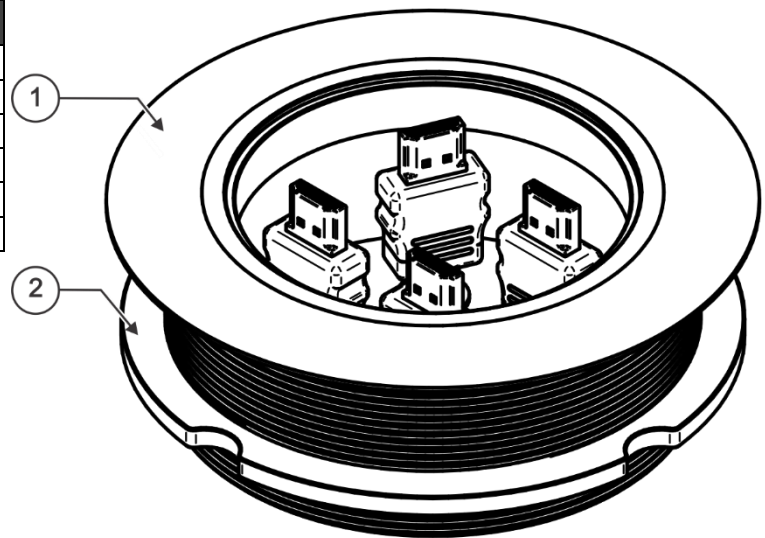

Step 3: Mount RTBUS-4C

To mount RTBUS-4C:

1. Cut a hole in the table 115mm in diameter.
2. Remove the four inner plate screws and remove the inner plate from the enclosure.
3. Run the cables under the table, through the locking ring, and up through the hole in the table.
4. Insert the cables into the bushings on the slots of the inner plate.
5. Place the inner plate into the enclosure and secure the four screws.
6. Place the enclosure into the hole in the table and secure it with the locking ring.
7. Secure the locking ring with the locking ring screw.

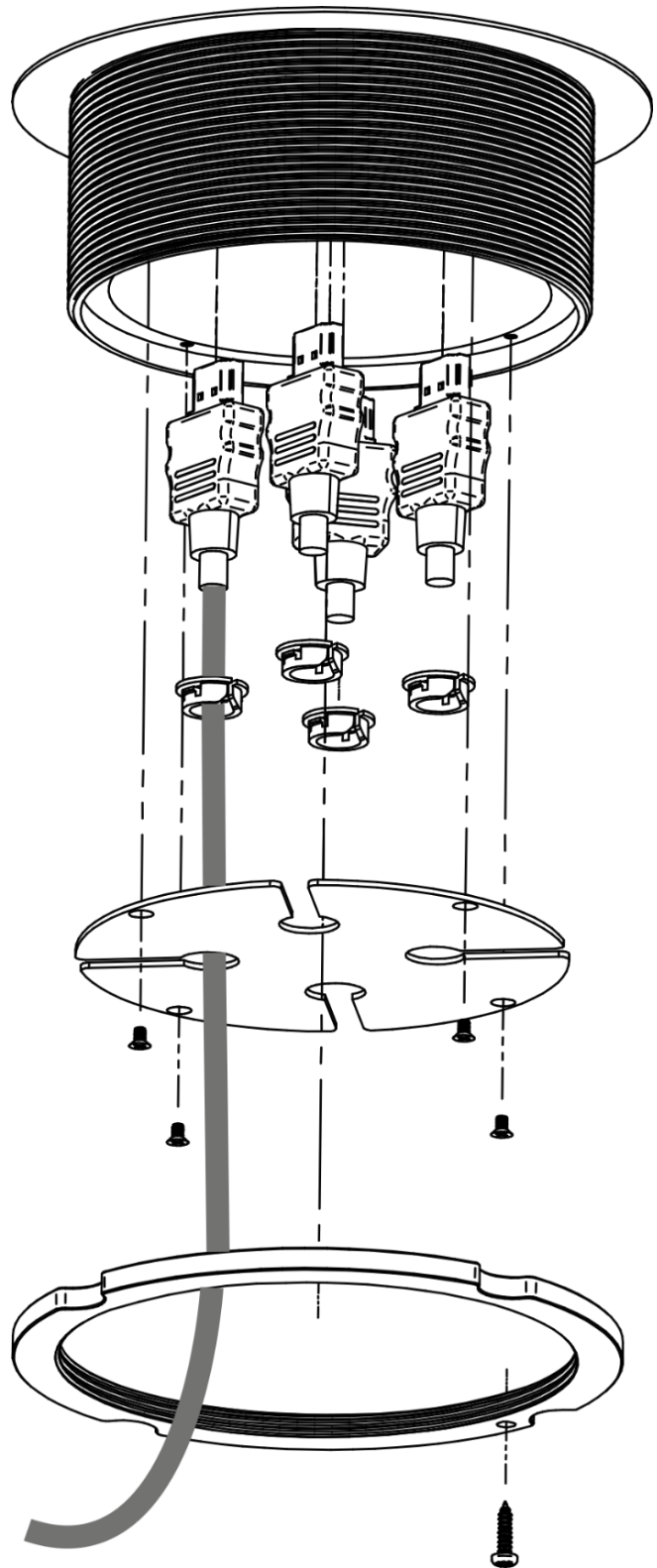

Technical Specifications

Compatibility	Maximum Cable Diameter	8mm
	Minimum Strain Relief Width	9mm
Physical	Enclosure & Locking Ring Material	Aluminum
	Inner Plate Material	Steel
	Cutout Dimensions	115mm Ø
	Weight	0.55kg

Specifications are subject to change without notice at www.kramerav.com

The terms HDMI, HDMI High-Definition Multimedia Interface, and the HDMI Logo are trademarks or registered trademarks of HDMI Licensing Administrator, Inc.