

# EENOUR

## 2 in 1 Tumbler & Hat Press

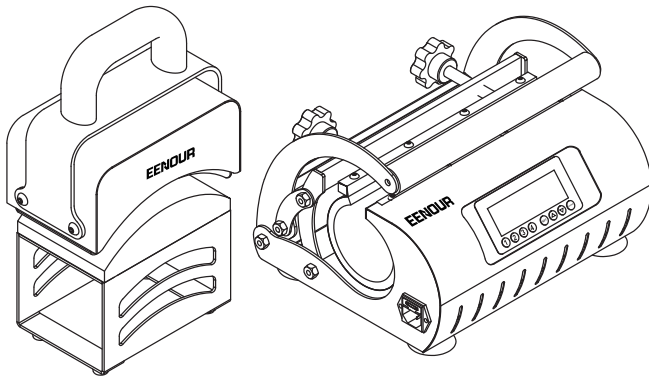

## User Manual

---

Model: CH2302

Please read this manual before use and follow its guidance.  
Keep this manual for future reference.

---

# INTRODUCTION

Thank you for purchasing the EENOUR 2 in 1 Tumbler & Hat Press Machine. Before use, please read the user manual of this product to ensure correct use after a complete understanding. After reading, please keep the user manual in a safe place for future reference. If you need any assistance, please contact our support team at: [support@eenour.com](mailto:support@eenour.com) with your product model number and Amazon order number.

# SAFETY INSTRUCTIONS

## Using Notes:

1. Check the voltage before using it.
2. Do not heat the tumbler machine without a tumbler inside in case of burnout and reducing the life of the heater.
3. Return the hat press machine to the base when it's heating or not in use.
4. Use in a well-ventilated area – vapors from the heating process may irritate sensitive smells.
5. Keep the tumblers, hats, and designed heat transfer sheet completely dry.
6. Please take the sample to test first. The temperature and time depend on the material of the sheet, tumblers, hats and pressure.
7. Plastic products cannot be heat pressed.
8. Do not allow the cord to touch hot surfaces, and remember to turn off and unplug the machine, and let it cool completely before handling or storing.
9. Do not clean the tumbler heating element and curved hat heat plate with water.
10. It's recommended to use lubricating oil for regular machine connection maintenance.

## Note the Cup Types:

1. The cups must have a sublimation layer.
2. The cups should be straight-walled, between 2.65" and 3.2" in diameter, and under 10.6" in length. If the cup is not in this range, you can replace a right size attachment to heat press it.
3. Sublimation cups made of stainless steel, glass, ceramics, and enamel can be heat pressed, while plastic and paper cups are not suitable.

## Note the Hat Types:

1. Make sure the hat is not lined, otherwise, it will completely melt under a heat press.
2. Not suitable for graduation caps as the cap itself is lined with fabric that melts at high temperatures.
3. It's not recommended that you do infusible ink or sublimation on the brim as you may damage the inner structure of the brim.
4. The visor (cotton or polyester) may have light indentations after being pressed, which can be flattened with a scraper.

# SPECIFICATIONS

<b>Product Name</b>	2 in 1 Tumbler & Hat Press	<b>Model</b>	CH2302
<b>Temp. Range</b>	0-400°F/0-204°C	<b>Voltage</b>	110V
<b>Time Range</b>	0-399s	<b>Power</b>	500W Max
<b>Tumbler Heat Attachment</b>	(D)2.7~3.2 inches (6.8~8.1cm) (H)10.6 inches (27cm) max	<b>Tumbler Press Size</b>	12.4*10.6*8.3inch (31.5*27*21cm)
<b>Curved Heat Element</b>	3.15*5.5inch / 8*14cm	<b>Hat Press Size</b>	8.9*5.9*3.6inch (22.5*15*9cm)

## Get to Know EENOUR 2-in-1 Tumbler & Hat Press

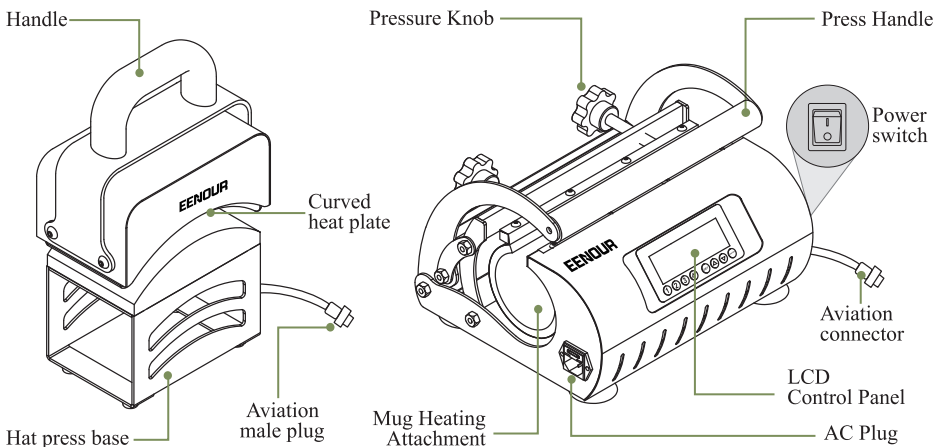

### Note:

The main controller can only power and control one machine at a time. Please connect the corresponding aviation plug to power it.

# Know the Control Panel

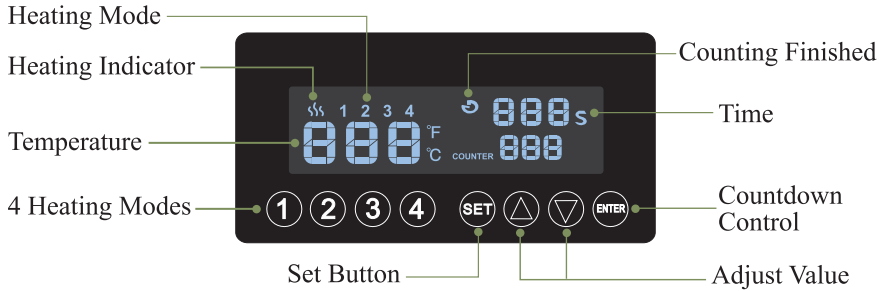

## How to Operate Control Panel

### 1. How to switch between °F and °C



1. Long press the "SET" button for 3 seconds, then press "Δ" to "SV=88"



2. Short single press the "SET" button 8 times to switch the above panel, then press the "Δ" and "∇" buttons to switch between 1=°F and 0=°C.



3. Long press the "SET" button for 3 seconds again to save the setting.



As shown above, the current temperature unit is °C.

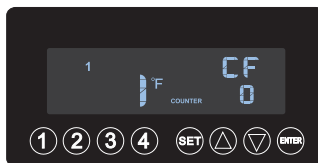

As shown above, the current temperature unit is °F.

## 2. How to set the temperature and time of the 4 heating modes?

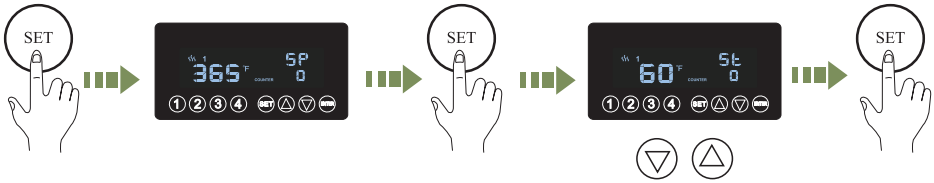

**Note:** The machine has the following 4 temperature and time settings by default. If you want to adjust the parameters of the 4 modes, please follow the steps above.

	Mode 1	Mode 2	Mode 3	Mode 4
Temperature	360°F	360°F	390°F	360°F
Time	50s	90s	200s	30s
Suitable for	stainless cups	sports bottles/glass	ceramic cups	hats

# OPERATION STEPS GUIDE

## 1. How to heat press a tumbler

### Part 1: Preparation Work



1. Use a printer with sublimation ink to print the pattern on sublimation paper, or prepare the printed sublimation paper.



2. Wrap the printed paper on a blank tumbler using thermal tape.



3. Put the tumbler into the heater.



4. Press down the handle and turn two pressure knobs at the same time to adjust the pressure.

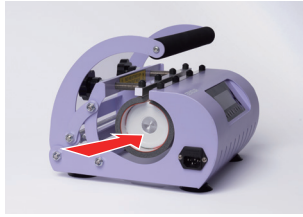

5. Push the bottom of the tumbler to make sure it does not move, in this case, the pressure is suitable.



6. Pull up the handle and take the tumbler out.

## Part 2: Steps to Print a Tumbler



1. Connect the aviation connector of the tumbler heater;

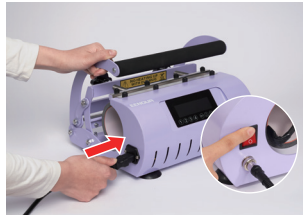

2. Plug in power and turn on the machine;



3. Choose a heat press mode, and then adjust the temperature and time if needed. (For temperature and countdown setting operation, please return to p4; For the printing parameters, please move to p9);



4. Wait until the machine heats up to the set temperature (Place a blank tumbler in when the machine is heating to prolong the life of the heating accessories);



5. Wear heat-resistant gloves, put the tumbler into the heater, press down the handle, and then press "ENTER" to start the countdown.



6. After the countdown is completed, pull up the handle and set a temperature and countdown time for the gap side.

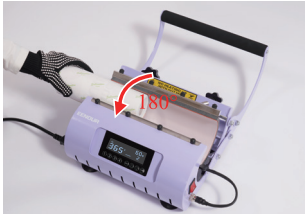

7. Flip the tumbler 180°, pull down the handle and press "ENTER" to start the countdown.



8. After the countdown is completed, take out the tumbler and check the printing.

### Note:

- Step 6 and Step 7 are necessary for fully wrapped pictures because there is a gap between the sides of the heater.
- Flip 180° heating to make sure another side heat enough, achieving better results.

## 2.How to heat press a hat

### Part 1: Preparation Work

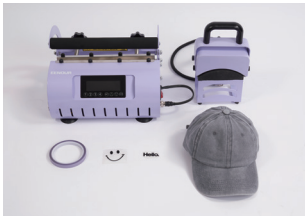

1. Prepare a heat-transfer vinyl film, transfer paper, or sublimation paper with a pattern.



2. Fix it on the hat using heat-resistant tape.



3. Make sure the hat and patten are flat and tight.

### Part 2: Steps to Print a Hat



1. Connect the aviation connector of the hat press;



2. Plug in power and turn on the machine;



3. Choose a heat press mode, and then adjust the temperature and time if needed. (For temperature and countdown setting operation, please return to p4; For the printing parameters, please move to p8);



4. Wait until the machine heats up to the set temperature.



5. Press "ENTER" to start the timer, and heat press your caps.



6. Stays for a suitable time. (If the pattern cannot be fully heated, tightly move the heated plate on the pattern)



7. After finished, put out the hat and place the hat press on the safety base.



8. Tear off the paper and enjoy it. (Please check if your material requires hot or cold tear off)

## Note:

Please wear heat-resistant gloves during operation.

Please cover the heat press part with butcher paper or baking paper during use to avoid burning the hat.

## How to Change the Heating Attachment?



1. Turn off the machine, disconnect the aviation connector of the heater, and plug out the power cord.



2. Remove the 8 screw caps, and place them well.



3. Take out the attachment from the left or right side;





4.Put a new heating attachment in, make sure all the screw holes coincide;



5.Fix the new attachment with the screws in the amount it needs;



6.Plug in the connecting cable.

## How to Change the Fuse?



1.Turn off and unplug the power;



2.Pry off the fuse holder cover and take it away;



3.Take out the old fuse and put in the new one (15A, 5×20mm);



4.Close the fuse cover;

## Printing Parameters for Cups

Material	Temperature	Time	Machine Status
Straight stainless steel tumbler	356°F-365°F	50s+50s/90s+40s	Hot(> 140°F)
Porcelain mug	374°F-392°F	200s	Hot(> 140°F)
Glass tumbler	356°F-392°F	60s+60s	Hot(> 140°F)

## Printing Parameters for Hats

	HTV				Heat Transfer Paper		Sublimation Paper
	Flocking	PU Matte	PU	Printable	Dark color	Light color	
Cotton	329°F 25s	356°F 25s	329°F 15s	356°F 25s	356°F,25s	329°F,25s	
Polyester	Cools off	Heats off	Cools off	Cools off			356°F,35s

### Note:

- 1.The temperature and time of heating transfer depend on the material and thickness of the transfer pattern.
- 2.The above parameters are for reference only. It's recommended to test first before mass production.

# TROUBLE SHOOTING

Fault	Possible Causes	Solutions
No display after powering up.	Poor outlet contact or the fuse is blown.	<ol style="list-style-type: none"> <li>1. Check the power cable and check the outlet.</li> <li>2. Make sure the heater attachment is connected.</li> <li>3. Replace with the supplied backup fuse.</li> </ol>
Heats unevenly or fails to heat up to the temperature displayed. ( $\pm 50^{\circ}\text{F}$ available)	The tumbler heating attachment is burnt out.	<ol style="list-style-type: none"> <li>1. Check the heating attachment connections.</li> <li>2. Replace the heating attachment. (If it's in 6 months warranty, pls contact us by email)</li> </ol>
The temperature will up and down during use.	The machine is keeping the temperature.	It's a normal phenomenon and will not influence results.
Faded and ghosting images.	<ol style="list-style-type: none"> <li>1. Insufficient temperature and press time.</li> <li>2. The paper is not wrapped tight or flat on mugs.</li> <li>3. The pressure is not suitable.</li> </ol>	<ol style="list-style-type: none"> <li>1. Increase the temperature and time.</li> <li>2. Make sure the paper is firmly wrapped and flat, and fully tape the top and bottom.</li> <li>3. Twist the pressure knobs to increase the pressure on the tumblers.</li> </ol>
The ink from the marker projects bleeds onto the mug heating element.	<ol style="list-style-type: none"> <li>1. The transfer paper is too thin.</li> <li>2. The ink pattern is too dark.</li> </ol>	<ol style="list-style-type: none"> <li>1. Wrap a mug with butcher paper to prevent transferring onto future projects.</li> <li>2. DO NOT clean with water that may cause a short circuit. In this case, please buy a new mug heating element to replace it.</li> </ol>
There is a strange smell during heating.	It's a sublimation smell and a normal phenomenon.	<ol style="list-style-type: none"> <li>1. The smell will reduce with time of use.</li> <li>2. Please use it in a ventilated place, or open the door or window.</li> </ol>

# WARRANTY

The product is with a 6-month warranty from the date of purchase (damages from normal wear and tear, alteration, misuse, neglect, accident, service by anyone other than the authorized service center, or act of God are not included).

During the warranty period and upon verification of defects, this product will be replaced or returned with proof of purchase.

## **Customer Support**

If you need help regarding product issues, after-sales service, or other relevant problems, please contact us via email: [support@eenour.com](mailto:support@eenour.com), and provide the following information:

- Order ID
- Problem description

**E-mail:** [support@eenour.com](mailto:support@eenour.com)

**Website:** [www.eenour.com](http://www.eenour.com)