

# EENOUR

## Tumbler Mug Press

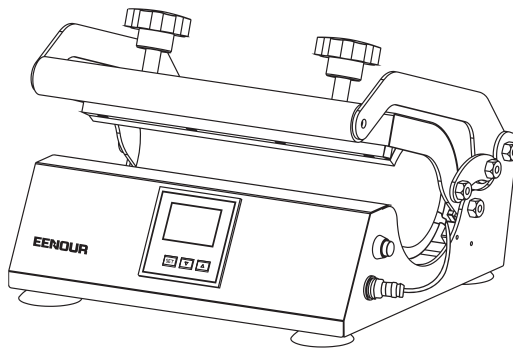

## User Manual

---

Model: CH2242

Please read this manual before use and follow its guidance.  
Keep this manual for future reference.

---



# INTRODUCTION

Thank you for purchasing the EENOUR Tumbler Mug Press. Before use, please read the user manual of this product to ensure correct use after a complete understanding. After reading, please keep the user manual in a safe place for future reference. If you need any assistance, please contact our support team at: [support@eenour.com](mailto:support@eenour.com) with your product model number and Amazon order number.

# SAFETY INSTRUCTIONS

1. Don't touch the tumbler heater as the machine is heating or still hot.
2. Remember to turn off the machine after using it.
3. This machine is not intended for use by children.

## Notes:

1. Check the voltage before using it.
2. Do not heat the machine without a tumbler inside in case of burnout and reducing the life of the heater.
3. If the machine works for more than 1.5 hours, it is better to turn it off for a 20-minute break.
4. Use in a well-ventilated area – vapors from the heating process may irritate sensitive individuals.
5. Plastic products cannot be heat pressed.
6. Unplug the machine and allow it to cool completely before handling or storing.
7. Do not clean the mug heating element with water.
8. Use lubricating oil for regular machine connection maintenance.
9. Keep the designed sublimation paper completely dry.
10. Please take the sample to test. The sublimation temperature and time depend on the sublimation tumbler you purchased.

# SPECIFICATIONS

Product Name	CH2242 Tumble Mug Press	Voltage	110V
Temp. Range	0~400°F (0~204°C)	Power	500W
Time Range	0-999 seconds	Item Size	11.8*9.1*10.6inch
Printable Size	aprox. 11 oz to 30 oz (D)2.7~3.2 inches (H)10.6 inches max	Item Weight	13.8lbs(6.26kg)

## GET TO KNOW EENOUR CH2242 TUMBLER MUG PRESS

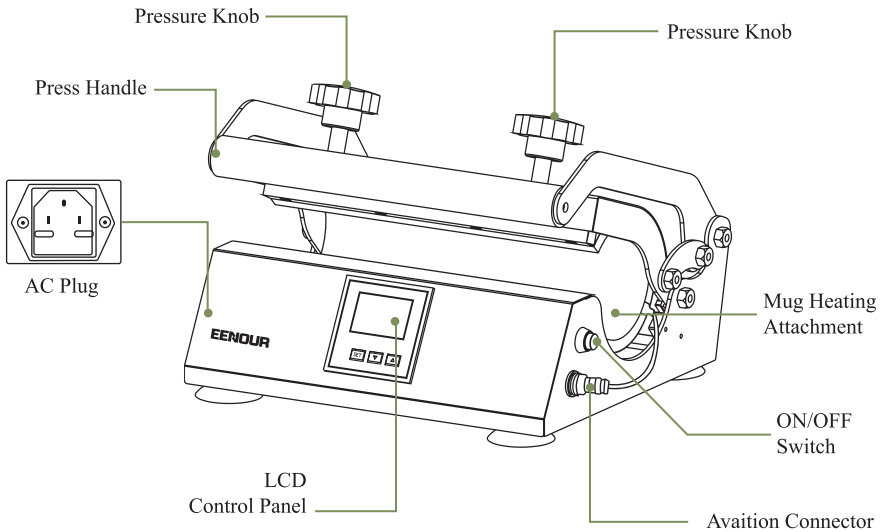

# Know the Control Panel

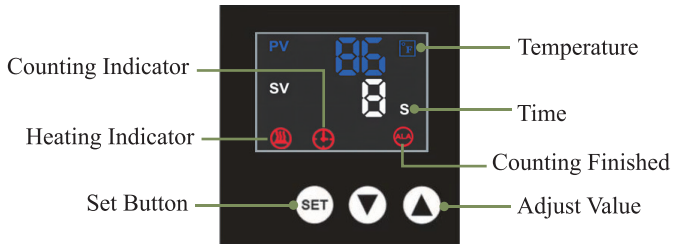

# How to Operate Control Panel

## How to switch between °F and °C?

1. Long press the "SET" button for 3 seconds to "PV=Lo", then press "Δ" to "SV=88"

2. Short single press the "SET" button to "PV=CF" in the panel, then press the "Δ" and "▽" buttons to switch between 1=°F and 0=°C.

3. Long press the "SET" button for 3 seconds again to save the setting.

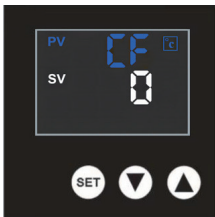

As shown above, the current temperature unit is °C.

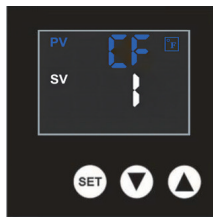

As shown above, the current temperature unit is °F.

## How to set printing time and temperature?



1.Plug in power and press the power button(red), press the "SET" button once and "SP" shows on the screen, which means it's in temperature setting mode. Press the "△" and "▽" buttons to adjust the temperature.

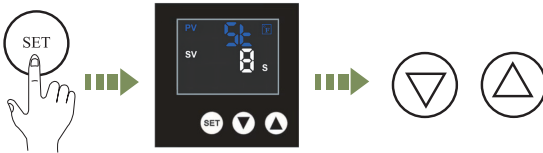

2.Press the "SET" button again and "ST" shows on the screen, which means it's in time setting mode. Press the "△" and "▽" buttons to adjust the counting time.



3.At Last, long press the "SET" button to save the settings and exit setting mode.

**Note:** Countdown will start automatically when you press down the handle well.

## OPERATION STEPS GUIDE

### Part 1: Preparation Work



1. Print the pattern on sublimation paper, or prepare the printed sublimation paper.



2. Fix the image paper on a blank tumbler using thermal tape.



3. Put the tumbler into the heater.



4. Turn two pressure knobs at the same time and press down the handle to adjust the pressure.

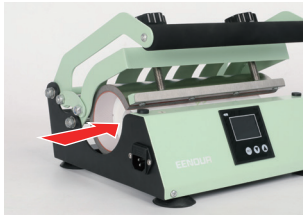

5. Push the bottom of the tumbler to make sure it does not move, in this case, the pressure is suitable.



6. Pull up the handle and take the tumbler out.

## Part 2: Steps to Print a Tumbler



1. Connect the aviation connector of the heater.



2. Plug in power and press the power button.



3. Set printing temperature and countdown time (For temperature and countdown setting operation, please return to p4; For the printing parameters, please move to p7).



4. Wait until the machine heats up to the set temperature (Place a blank tumbler in, do not heat the machine without a tumbler inside).



5. Wear protective gloves, put the tumbler into the heater.



6. Press down the handle, and the machine starts countdown.



7. After the countdown is completed, pull up the handle and set a temperature and countdown time for another side.

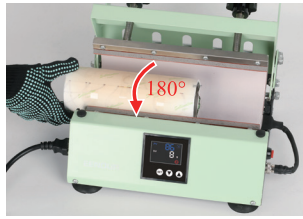

8. Flip the tumbler 180° and press down the handle, and the machine starts a countdown;



9. After the countdown is completed, take out the tumbler, turn off the power and check the printing.

## Note:

Step 7 and Step 8 are for sublimation tumblers with a full pattern, and flipping 180° heating is to make sure all sides heat pressed and to get a perfect result.

# HOW TO CHANGE THE HEATER?



1. Turn off the machine, and unplug the connecting cable of the heater.



2. Unscrew the heater.

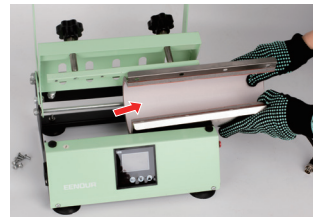

3. Take out the heater from the left or right side.

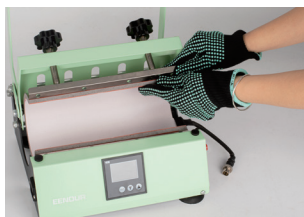

4. Put the new heater in, make sure all the screw holes coincide.



5. Fix the new heater with the screws in the amount it needs.



6. Plug in the connecting cable.

## Note:

Spare tumbler heating attachment is not included, which is available on the EENOUR Direct US store.



# HOW TO CHANGE THE FUSE?



1. Turn off and unplug the power.

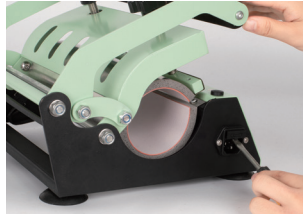

2. Pry off the fuse holder cover and take away.



3. Take out the old fuse and put in the new one (15A, 5×20mm).



4. Close the fuse cover.

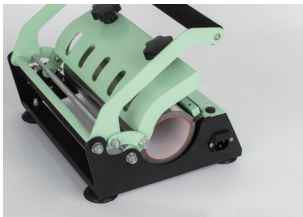

5. Make sure the fuse is installed tightly.



6. Plug in and turn on the power.

# PRINTING PARAMETERS

Material	Machine Status	Temperature	Time
Straight stainless steel tumbler	Hot(> 140°F)	356°F-365°F	50s+50s/90s+40s
Porcelain mug	Hot(> 140°F)	374°F-392°F	200s
Glass tumbler	Hot(> 140°F)	356°F-378°F	300s+200s/ 60s+60s

Compatible Diameter: 2.7-3.2inch (6.8-8.1cm)

Max. Printable Length: 10.6inch (27cm) max

Suitable For: Most 11-30oz

Note: The parameters above are for reference only. Please test to find the best parameters for your own tumblers.

# TROUBLE SHOOTING

Fault	Possible Causes	Solutions
No display after powering up.	Poor outlet contact or the fuse is blown.	<ol style="list-style-type: none"> <li>1. Check the power cable and check the outlet.</li> <li>2. Make sure the heater attachment is connected.</li> <li>3. Replace with the supplied backup fuse.</li> </ol>
Fails to heat up or does not heat up to the temperature displayed. ( $\pm 50^{\circ}\text{F}$ available)	The mug heating attachment is burnt out.	<ol style="list-style-type: none"> <li>1. Check the heating attachment connections.</li> <li>2. Replace the heating attachment.</li> </ol>
Lack of color, faded image.	Because of the insufficient temperature and press time, the design is not tight or completely flat against the mug.	Make sure the design is firmly secured and flush against the mug. Adjust the temperature or increase the heating time.
Darkened, deep color, blurred image.	The temperature was too hot or pressed for a long time.	Set a lower temperature or time. Try more to get a suitable temperature and time for your mug.
The ink from the marker projects bleeds onto the mug heating element.	The transfer paper is too thin.	DO NOT clean with water that may cause a short circuit. You can wrap a mug with butcher paper to prevent transferring onto future projects or buy a new mug heating element to replace it.

<p>The handle cannot hold on by itself, and automatically falls down to start the countdown.</p>	<p>The screws on both sides are loose.</p>	<ol style="list-style-type: none"> <li>1. Please tighten the screws on both sides.</li> <li>2. Contact us for a more detailed operation guide if it cannot be solved by yourself.</li> </ol>
<p>The sucker legs are unstable or fall off.</p>	<p>The screws fixing the suction cup are loose or dropped</p>	<ol style="list-style-type: none"> <li>1. Please tighten or install the screws and suction cups for the back legs.</li> <li>2. For the front legs, please recover the front cover of the machine, and then tighten or install them.</li> <li>3. Contact us for a more detailed operation guide if it cannot be solved by yourself.</li> </ol>

## WARRANTY

The product is with a 6-month warranty from the date of purchase (damages from normal wear and tear, alteration, misuse, neglect, accident, service by anyone other than the authorized service center, or act of God are not included).

During the warranty period and upon verification of defects, this product will be replaced or returned with proof of purchase.

### Customer Support

If you need help regarding product issues, after-sales service, or other relevant problems, please contact us via email: [support@eenour.com](mailto:support@eenour.com), and provide the following information:

- Order ID
- Problem description

**E-mail:** [support@eenour.com](mailto:support@eenour.com)

**Website:** [www.eenour.com](http://www.eenour.com)

