

PAGING AMPLIFIER

PG-20C
PG-50C
PG-100C

- INSTRUCTIONS -

PG-C Series Amplifiers, with built-in paging adaptors, are designed for use with Aiphone paging/intercom systems. 20, 50 and 100 watt models are available.

1 PRODUCT FEATURES



- Built-in Aiphone paging adaptors (MC-A, PD-1, PD-2).
- For use with Aiphone intercom systems MC-60/4, TD-H/Z, RAX, RCX, YKX, or as a stand-alone.
- Telephone system interface for paging.
- Full range volume and tone controls.
- Short circuit and overload protected.
- Separate bass and treble controls for paging and music.
- Adjustable background music volume control.
- Adjustable paging pre-tone volume control.
- Dry contact or VOX music mute (Mic or Tel).
- Black anodized brushed aluminum finish with ABS end panels.
- Integrates with intercom system power supply (PS-1224C) and optional tuner (PGT-8).
- NRTL/C certified (complies with both UL & CSA standards).

2 NAMES AND FUNCTIONS

The following controls and terminals may be accessed by removing the screw on the bottom of the unit and lifting the lower cover.

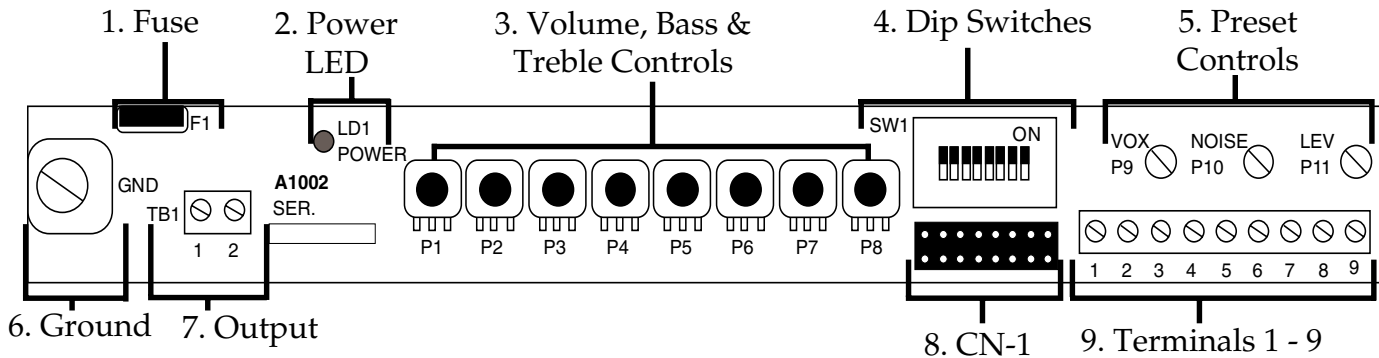

1. FUSE

Replace fuse with 3AG SloBlo's only in the following ratings:
 PG-20C 3/4 Amp PG-50C 1-1/4 Amp PG-100C 2 Amp

2. POWER L.E.D.

Indicates that the amplifier is on or off.

3. VOLUME, BASS & TREBLE CONTROLS

These controls are normally set at the time of installation, purposely protruding only slightly from the cover so that they can be adjusted if necessary, but are less susceptible to accidental change.

A) PRE-TONE Volume - P1

Adjusts the level of the pre-tone signal over the speakers.

B) MUSIC/AUX Volume - P2, Bass - P3, Treble - P4

Adjusts the level, treble and bass of the background music.

C) TEL/MIC Volume - P5, Bass - P6, Treble - P7

Adjusts the level of the telephone/microphone input separately from the music controls.

D) Adaptor Volume - P8

Adjusts the volume level of the paging via the Aiphone intercom/paging system.

4. DIP SWITCHES

A) Dip switches 1 & 2 - Telephone/Microphone

If a telephone system is used, set both switches to the ON position.

If an external microphone is used, set both switches to the OFF position.

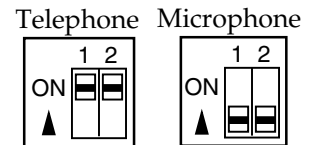

B) Dip switch 3 - VOX (Voice activated switch)

Set this switch to the ON position if VOX music muting is going to be used with tel/mic paging.

C) Dip switches 4 & 5 - Talk battery

Set both switches to the ON position to enable this function. This option provides a talk battery to the telephone set or telephone system C.O. trunk.

D) Dip switch 6 - Pre-tone

Set this switch to the ON position to enable the Pre-tone function.

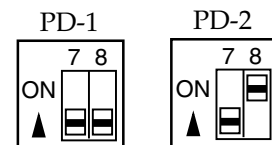

E) Dip switches 7 & 8 - Paging adaptor option

For PD-1 adaptor, set both switches to the OFF position.

(The PD-1 is used for paging in the TD-H and TD-Z systems)

For PD-2 adaptor, set switch 7 to the OFF position and switch 8 to the ON position.

(The PD-2 is used for paging and talkback in the TD-H and TD-Z systems)

For MC-A adaptor, set switch 7 to the ON position and switch 8 to the OFF position.

(The MC-A is used for paging with the MC-60/4, RAX, RCX, and YKX systems)

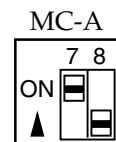

2

NAMES AND FUNCTIONS - CONT.

5. PRESET CONTROLS

A) VOX - P9 (Voice activated switch)

This pot adjusts the sensitivity of the VOX threshold of the tel/mic input. Make adjustments as follows:

- 1) Set the VOX control fully counter clockwise (CCW) (background music should be on).
- 2) While someone is talking in the page mode, slowly turn the control clockwise (CW) until the VOX circuit triggers and the background music cuts off.
- 3) Turn the control an additional 1/8 turn CW and leave at this setting.

If the VOX function has a tendency to drop out, slightly increase (CW) the control setting.

B) Noise - P10 (Talkback background noise balance)

This pot cancels the background noise in the talkback circuit which may be induced into the speaker wiring by an outside source. (For use with the PD-2 talkback paging adaptor only.)

C) Level - P11

This pot sets the talkback level of the amplifier. (For use with the PD-2 talkback paging adaptor only.)

6. GROUND TERMINAL

A chassis ground has been provided to allow separate grounding of the unit, if required.

7. OUTPUT

Connect speaker wires to the terminals labelled OUTPUT. The rated output of all amplifiers is 70V RMS.

Note: To prevent any possible oscillation ensure that the speaker wires are kept away from any input wiring connected to the terminal strip described below (Item 9).

8. CN-1

CN-1 is provided on the amplifier to allow easy direct plug-in of the matching AM/FM tuner (PGT-8), via a ribbon cable included with the tuner.

9. TERMINALS 1-9

In accordance with your particular system installation and requirements, make the following connections at the terminal block at the right.

A) Terminals 1 & 2 - **Tel/Mic** (Balanced Input)

Connect to either the telephone system page port, C.O. port, a telephone set or an external microphone (600Ω balanced - shield to pin 3) to these terminals. Depending on which source is used, dip switches 1 & 2 must be set accordingly.

This voice input can only be activated by the page port dry contacts, the VOX circuit, the C.O. port talk battery circuit or a strap across pins 5 & 6.

CAUTION: This input must NOT be connected directly to the telephone network.

B) Terminals 3 & 4 - **Music/Aux** (Unbalanced Input) - (4 - Positive, 3 - Negative)

Connect a music source to these terminals noting that pin 3 is negative. Reversed connection can cause oscillation. It is important that shielded cable be used to avoid any induced hum. If you are using the matching PGT-8 tuner, follow the separate instructions included with the tuner. In applications where this amplifier is used with an external Aiphone paging adaptor, this input may be used as an AUX input with 10K ohms impedance.

C) Terminals 5 & 6 - **Music Mute**

When these two terminals are shorted together, the music/aux output of the amplifier will be muted to allow a tel/mic page to be heard.

D) Terminal 7 - **Page C/2**

Connect the appropriate leads from your Aiphone intercom system to this terminal. Refer to the following wiring diagrams for more details. Set dip switches 7 & 8 according to your system.

E) Terminals 8 & 9 - **12/24 VDC**

If an Aiphone intercom system is used in conjunction with this amplifier, connect the matching PS-1224C power supply for that intercom system to these terminals. Be sure to observe polarity.

24VDC: When using the built-in MC-A adaptor.

12VDC: When using the built-in PD-1/PD-2 adaptor.

3 INSTALLATION

1. Mount the amplifier on a wall or base plate capable of supporting its weight securely. Be sure no heat producing elements are nearby. Also be sure that the area behind the amplifier allows a clear path of air to flow and that the air slots at the top and bottom are not obstructed.

IMPORTANT: To comply with NRTL/C safety regulations, a minimum clearance of 6 inches must be maintained above the unit. (See picture at right.)

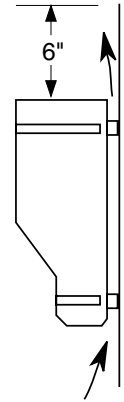

(Airflow)

2. Loosen, but do not remove the screw at the bottom of the unit to gain access to the terminals and switches under the lower cover.

3. Lift the cover all the way up. In the fully open position you can conveniently refer to the labelling which indicates the terminal connections and dip switch settings.

4. Make all the proper connections, determined by which system is being used in conjunction with the amplifier. (As you make your connections, the small "plate" rises from the bottom of the terminal to secure the wire.)

5. Connect the speaker line to the terminals labelled OUTPUT.

6. Set all appropriate switches and volume levels. (Refer to Names and Functions section.)

4 WIRING DIAGRAMS

MARKET COM MC-60/4

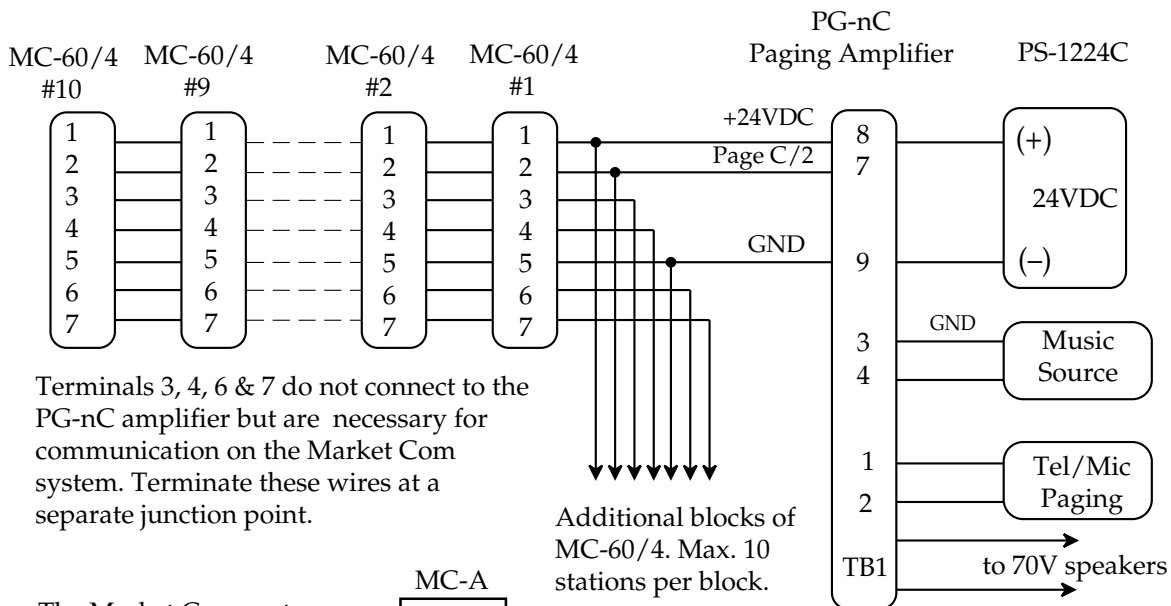

Terminals 3, 4, 6 & 7 do not connect to the PG-nC amplifier but are necessary for communication on the Market Com system. Terminate these wires at a separate junction point.

Additional blocks of MC-60/4. Max. 10 stations per block.

The Market Com system uses the built-in MC-A adaptor. Set switches 7 & 8 as follows:

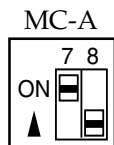

Note: To prevent any possible oscillation, ensure that the speaker wires are kept away from any input wiring connected to the terminal strip.

Note: When using the Tel/Mic input of a PG-C series amplifier, set dip switches 1&2 accordingly. Please refer to Names and Functions section.

4 WIRING DIAGRAMS - CONT.

TD-H/Z TELEPHONE TYPE SYSTEM

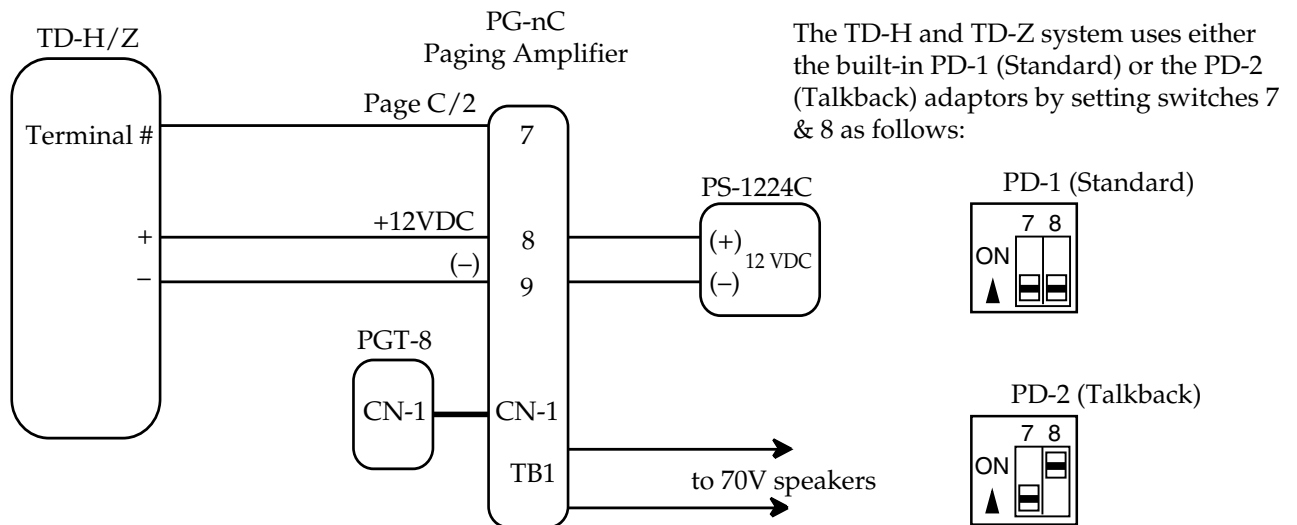

Note: To prevent any possible oscillation, ensure that the speaker wires are kept away from any input wiring connected to the terminal strip.

For each paging zone required, use the appropriate sized PG-C amplifier.

MICROPROCESSOR SYSTEMS (RAX, RCX, YKX)

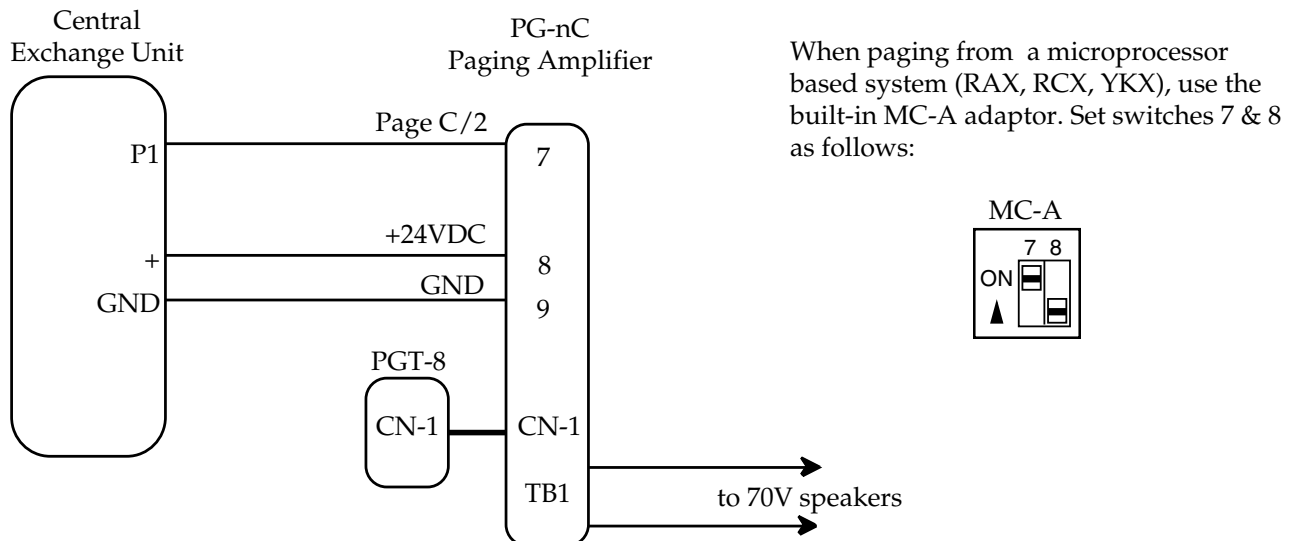

Note: To prevent any possible oscillation, ensure that the speaker wires are kept away from any input wiring connected to the terminal strip.

For each paging zone (up to a total of four), use the appropriate sized PG-C amplifier.

4 WIRING DIAGRAMS - CONT.

LEF SYSTEM

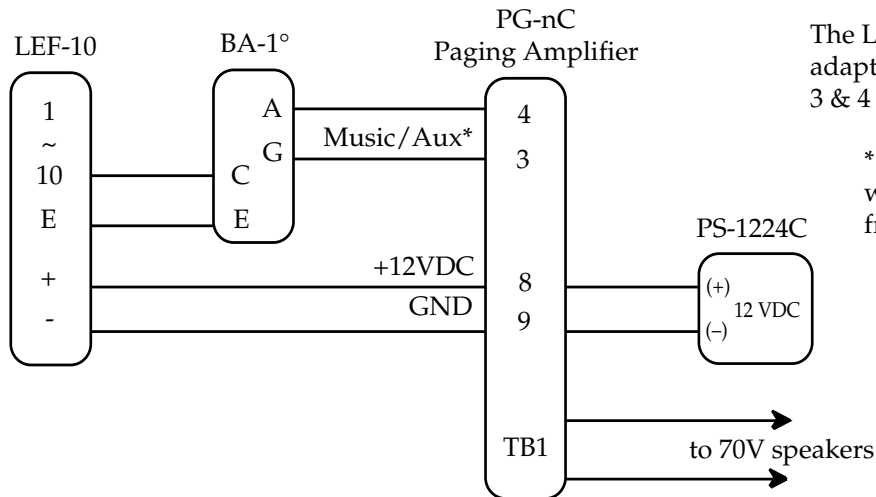

The LEF system will use a separate paging adaptor (not built-in), connected to the 3 & 4 terminals of the PG-C series amplifier.

* Note:: Paging through the Aux input will not mute the Music if provided from PGT-8 Tuner into CN-1.

Note: To prevent any possible oscillation, ensure that the speaker wires are kept away from any input wiring connected to the terminal strip.

° BA-1 is a Special Order Product.

For each paging zone required, use the appropriate sized PG-C amplifier.
For further information on these products, please refer to the instructions provided with each unit.

NEM SYSTEM

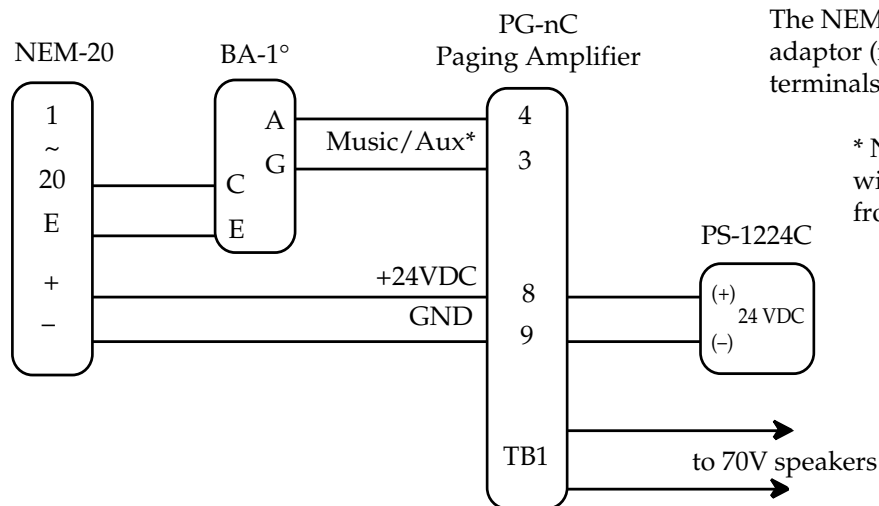

The NEM system will use a separate paging adaptor (not built-in), connected to the 3 & 4 terminals of the PG-C series amplifier.

* Note:: Paging through the Aux input will not mute the Music if provided from PGT-8 Tuner into CN-1.

Note: To prevent any possible oscillation, ensure that the speaker wires are kept away from any input wiring connected to the terminal strip.

° BA-1 is a Special Order Product.

For each paging zone required, use the appropriate sized PG-C amplifier.
For further information on these products, please refer to the instructions provided with each unit.

5

SPECIFICATIONS

PG-C Series Amplifiers

	PG-20C	PG-50C	PG-100C
Power Output	20 Watts RMS	50 Watts RMS	100 Watts RMS
Distortion	Less than 1% at 1,000 Hz rated output	Less than 1% at 1,000 Hz rated output	Less than 1% at 1,000 Hz rated output
Frequency response	±3 dB, 100 to 20,000 Hz	±3 dB, 100 to 20,000 Hz	±3 dB, 100 to 20,000 Hz
Inputs	Tel/Mic - 600Ω Balanced Music/Aux - 10 KΩ Page/C2-Input for intercom paging	Tel/Mic - 600Ω Balanced Music/Aux - 10 KΩ Page/C2-Input for intercom paging	Tel/Mic - 600Ω Balanced Music/Aux - 10 KΩ Page/C2-Input for intercom paging
Sensitivity	Tel - 150 mV Mic - 1 mV Music/Aux - 100 mV	Tel - 150 mV Mic - 1 mV Music/Aux - 100 mV	Tel - 150 mV Mic - 1 mV Music/Aux - 100 mV
Controls	Pretone Volume Music Volume Music Bass ±10 dB @ 100 Hz Music Treble ±10 dB @ 20 kHz Tel/Mic Volume Tel/Mic Bass ±10 dB @ 100 Hz Tel/Mic Treble ±10 dB @ 20 kHz	Pretone Volume Music Volume Music Bass ±10 dB @ 100 Hz Music Treble ±10 dB @ 20 kHz Tel/Mic Volume Tel/Mic Bass ±10 dB @ 100 Hz Tel/Mic Treble ±10 dB @ 20 kHz	Pretone Volume Music Volume Music Bass ±10 dB @ 100 Hz Music Treble ±10 dB @ 20 kHz Tel/Mic Volume Tel/Mic Bass ±10 dB @ 100 Hz Tel/Mic Treble ±10 dB @ 20 kHz
Output	70 Volts RMS	70 Volts RMS	70 Volts RMS
Power Source	120V AC, 60 Hz	120V AC, 60 Hz	120V AC, 60 Hz
Power Consumption	48 watts	80 watts	176 watts
Dimensions	W 12-3/4", H 7-1/2", D 3" (W 323, H 190, D 76 mm)	W 12-3/4", H 7-1/2", D 3" (W 323, H 190, D 76 mm)	W 12-3/4", H 7-1/2", D 3" (W 323, H 190, D 76 mm)
Weight	6.0 lb (2.7 kg)	7.6 lb (3.4 kg)	10.7 lb (4.8 kg)

All specifications are subject to change without notice.

LIMITED WARRANTY

Aiphone warrants its products to be free from defects in material and workmanship under normal use and service for a period of one year after delivery to the ultimate user. At our discretion, Aiphone will repair free-of-charge or replace at no charge a product should it, upon examination, be proven defective and under warranty. Aiphone reserves unto itself the sole right to make the final decision whether there is a defect in materials and/or workmanship, and whether or not the product is within the warranty.

This warranty shall not apply to any Aiphone product which has been subject to misuse, neglect, accident, or used in violation of instructions furnished, nor extended to units which have been repaired or altered outside of the factory.

This warranty does not cover batteries or damage caused by batteries. This warranty covers bench repairs only. Any repairs must be made at the shop or place designated in writing by Aiphone. Aiphone will not be responsible for any costs incurred involving on-site calls.

Aiphone Corporation
1700 - 130th Ave NE, Bellevue WA 98005
P.O. Box 90075, Bellevue WA 98009
(425)455-0510
Fax: (425)455-0071
PG-C-I(E) -99115- 0195A



Printed in Canada