

BV2-ES/BV3-ES SERIES

2-Way and 3-Way - Excavator Series - Block Style Body - Full Port

Carbon Steel and 316 Stainless Steel

Sizes: 1/4" thru 1-1/4"

BV2-ES

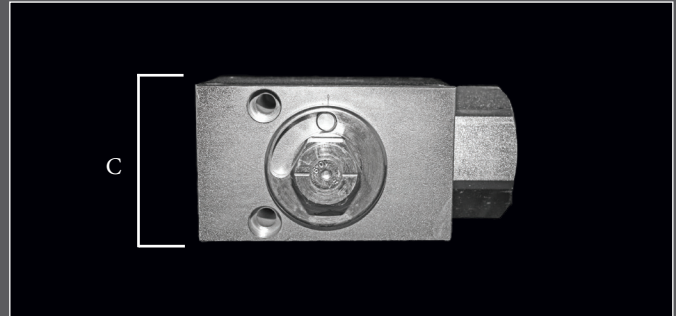
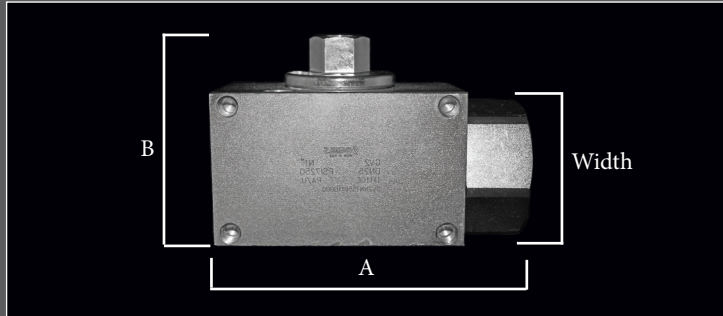

Features and Benefits

- Carbon steel and 316 Stainless Steel available
- Manufactured with two mounting holes
- Special design for high impulse applications
- Threads available: NPT and SAE
- Sizes: 1/4" thru 1-1/4" (Full Port)
- Standard POM ball seats with buna stem seals

Body Size	A	B	C	Width	Max Working Pressure (PSI)
04	3.37	2.26	1.46	1.06	7,250
06	3.48	2.26	1.46	1.26	7,250
08	4.07	2.46	2.46	1.42	7,250
12	5.10	3.05	3.05	1.77	7,250
16	5.26	3.44	3.44	2.17	7,250
20	5.26	4.07	4.07	2.36	7,250

units: inches

BV3-ES

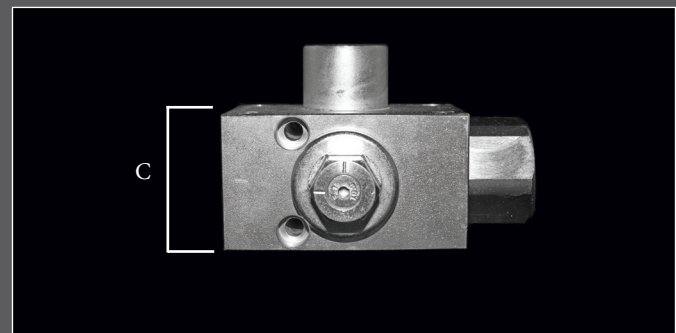
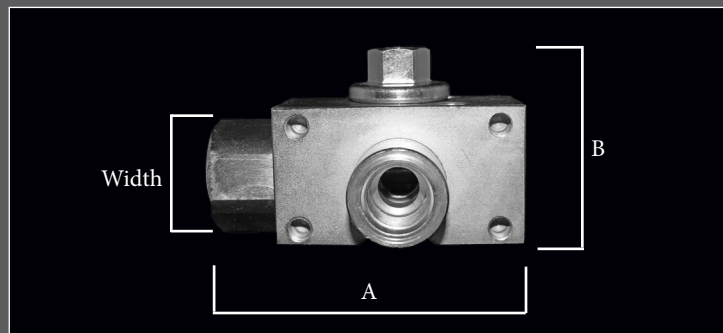

Features and Benefits

- Carbon steel and 316 Stainless Steel available
- Manufactured with two mounting holes
- Special design for high impulse applications
- Threads available: NPT and SAE
- Sizes: 3/8" thru 1-1/4" (1-1/4" reduced port)
- Standard POM ball seats with buna stem seals

Body Size	A	B	C	Width	Max Working Pressure (PSI)
06	3.48	2.26	1.46	1.26	7,250
08	4.07	2.46	2.46	1.42	7,250
12	5.10	3.05	3.05	1.77	7,250
16	5.26	3.44	3.44	2.17	7,250
20	5.26	3.44	3.44	2.17	7,250

units: inches

ORDERING INFORMATION

High Pressure Ball Valve Part Numbering System:

BV2-ES - SS - 08 - NPT

BV2-ES/BV3-ES Series		Material		Body Size		Thread Type	
BV2-ES	2-Way	(blank)	Carbon Steel	08	1/2"	Female NPT	
BV3-ES	3-Way	SS	316 Stainless	12	3/4"	Female SAE	
				16	1"		
				20	1-1/4"		