

Item # _____
 Qty # _____
 Model # _____
 Project # _____



DUKERS
 Quality Commercial Refrigeration

STOCK POT

DCSPB2



Catch Tray



Ventilation



Legs



Knobs



Cast Iron Cooking Surface



PRODUCT DESCRIPTION

- Stainless steel sides and front valve cover.
- Stainless steel tubing for pilots and pilot tips per burner ring.
- Heavy duty cast iron three-ring burner, rated at a total of 160,000 BTU/h.
- Each burner is equipped with two continuous pilots.
- Heavy duty cast iron and top grates.
- Two manual controls to operate the inner and outer rings independently.
- 3/4" NPT rear gas connection and regulator standard.
- Stainless steel legs standard.
- Full length seamless drip pan for easy cleanup.



HIGH QUALITY STAINLESS STEEL & ROBUST DESIGN



STOCK POT MODEL

DCSPB2

DIMENSION

Width	Depth	Height
18 in	42 1/4 in	18 in



Los Angeles | San Francisco | Dallas
 Houston | Florida | Chicago | New Jersey

1-800-931-8628

@ info@dukersusa.com

www.DukersUSA.com

DETAILS & SPECIFICATIONS

STOCK POT DCSPB2

Front View

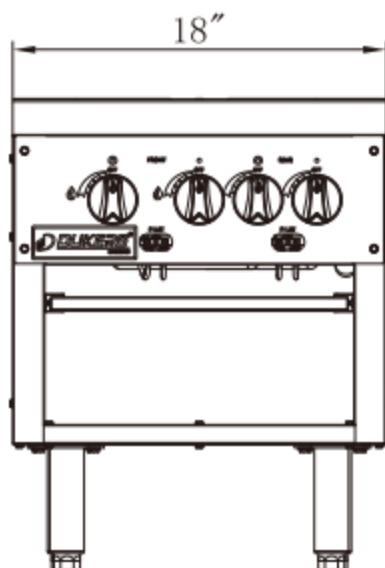

Top View

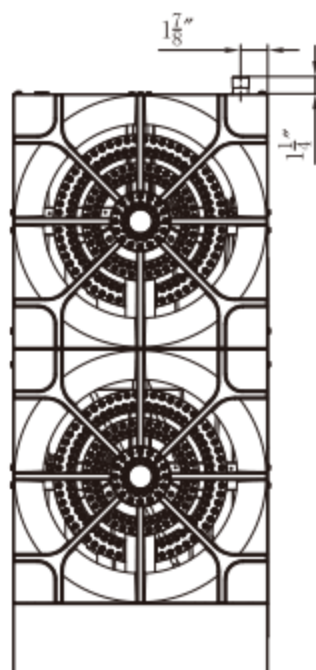

Side View

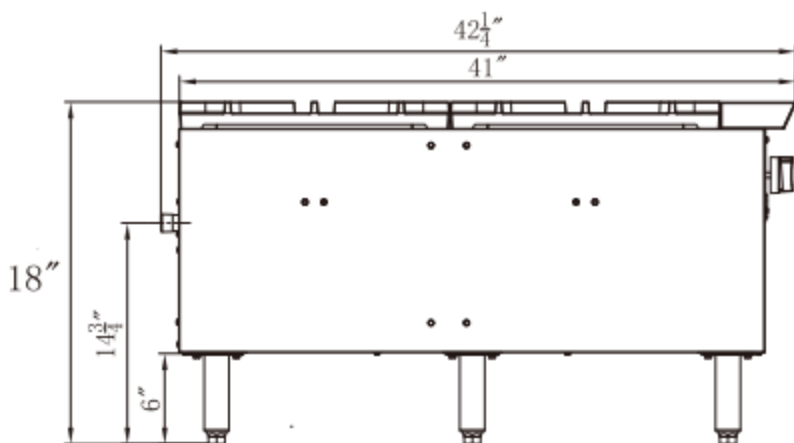

DCSPB2

GAS SOURCE	NG/Propane
COOKING AREA	18x49 1/4 in
BURNER	4 count
SINGLE BURNER	40000 BTU/H
COMBINED	160000 BTU/H
GAS PRESSURE	NG: 5 "WC Propane: 10 "WC
NOZZEL	NG: 32# Propane: 48#

Model	Packaging Dimensions (inches)			Net Weight (lbs)	Ship Weight (lbs)	Container Capacity 40'HQ
	W	D	H			
DCSPB2	21 1/8"	45 1/2"	22 1/2"	224	310	132



Los Angeles | San Francisco | Dallas
Houston | Florida | Chicago | New Jersey

1-800-931-8628

info@dukersusa.com

www.DukersUSA.com