

# PLSP Plateload Shoulder Press Machine

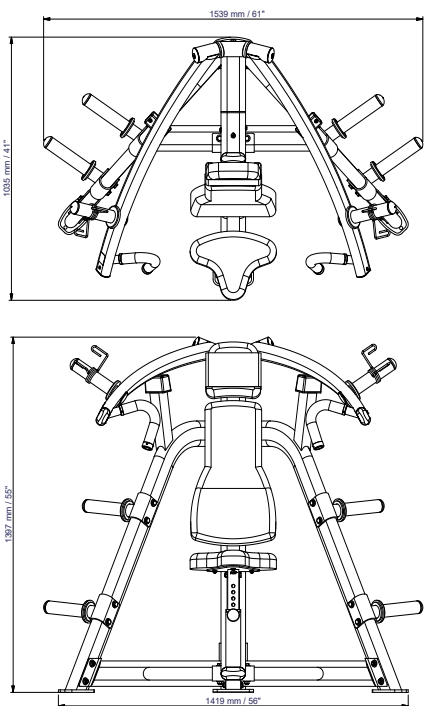

Get amazing results with this Steelflex Plate Load PLSP Shoulder Press, which has a 25-degree converging arm pattern that provides an exceptional range of motion. Both shoulder press arms can be used simultaneously or independently.

- Olympic weight posts (for use only with olympic weight plates)
- For both commercial and non-commercial use
- **Weight plates not included**

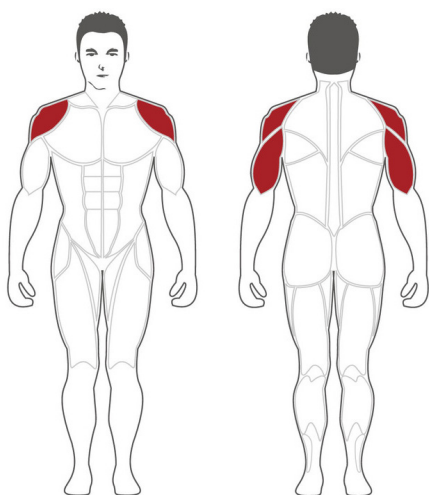

## FEATURES

- 12 gauge steel frame, 5 x 10 cm oval tubing
- Electrostatically applied powder coating
- 50 mm CGPC high density foam upholstery & ergonomic design
- Industrial rated bearings, sealed bearings at all pivot points
- Dipped PVC handle
- Continuous welds at all pivot points
- 25° converging pattern arm movement for advanced biomechanics and a natural range of motion
- Independent, unilateral arm action for balanced muscle development
- Stable foot platforms with moulded rubber and a antislip texture

## SPECIFICATIONS

Dimensions:	154 x 103.5 x 139.7 cm
Product weight:	87.5 kg
Max. user weight:	120 kg

## WARRANTY: COMMERCIAL AND RESIDENTIAL

Frame	15 years
Bearings	2 years
Upholstery & grips	6 months
Other parts	1 year