

PLLA **Plateload**

Lat Pull Down Machine

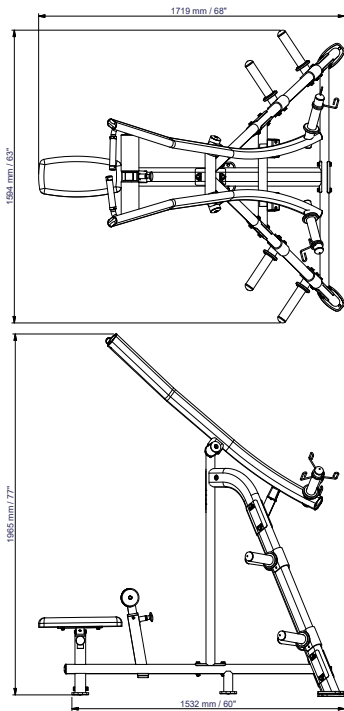

The Steelflex Plate Load PLLA Lat Pull Down is the ideal machine to add to the circuit of Steelflex Plateload machines. The PLLA Lat Pull Down will complete your muscle strength training.

- Olympic weight posts (for use only with olympic weight plates)
- For both commercial and non-commercial use
- **Weight plates not included**

FEATURES

- 11 gauge steel frame, 5 x 10 cm oval tubing
- Electrostatically applied powder coating
- Industrial rated bearings, sealed bearings at all pivot points
- Adjustable seat and leg hold-down bar to fit all size users
- Continuous welds at all pivot points
- Ergonomic hand grip positions, dipped PVC handle
- 50 mm CGPC high density foam upholstery & ergonomic design
- Converging press arm movement for advanced biomechanics
- Independent, unilateral arm action for balanced muscle development
- Foot platforms in moulded rubber with slip-resistant texture

SPECIFICATIONS

Dimensions:	172 x 159.4 x 196.5 cm
Product weight:	84 kg
Capacity weight:	225 kg
Max. user weight:	120 kg

WARRANTY: COMMERCIAL AND RESIDENTIAL

Frame	15 years
Bearings	2 years
Upholstery & grips	6 months
Other parts	1 year

