

PLHP Plateload Hack Press Machine

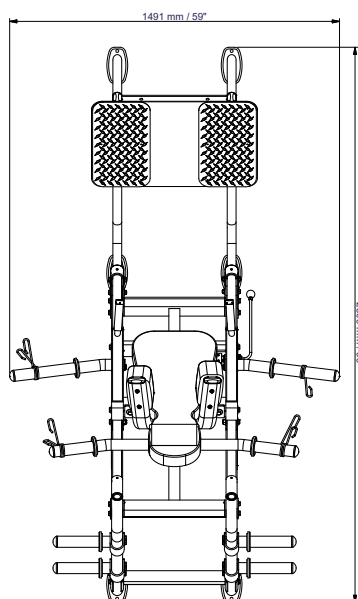

The Steelflex Plate Load PLHP Hack Press machine helps develop the quadriceps, glutes, hamstring and calves. The high-quality mainframe and soft sweat-resistant cushions are safe and easy to clean. The ergonomic design supports maximum workout with smooth linear movement and sturdiness. Adjustable for all heights and sizes.

- Olympic weight posts (for use only with olympic weight plates)
- For both commercial and non-commercial use
- **Weight plates not included**

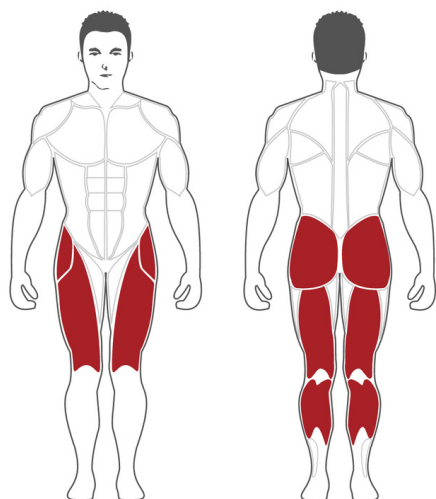

FEATURES

- 12 gauge steel frame, 5 x 10 cm oval tubing
- Electrostatically applied powder coating
- 50 mm CGPC high density foam upholstery & ergonomic design
- Industrial rated bearings, sealed bearings at all pivot points
- Dipped PVC handle
- Continuous welds at all pivot points
- Smooth linear movement and sturdiness
- Easy to clean sweat-resistant pads
- Adjustable

SPECIFICATIONS

Dimensions:	251 x 149 x 133.2 cm
Product weight:	171 kg
Max. user weight:	120 kg

WARRANTY: COMMERCIAL AND RESIDENTIAL

Frame	15 years
Bearings	2 years
Upholstery & grips	6 months
Other parts	1 year