

# PLHE Plateload Hip Extension

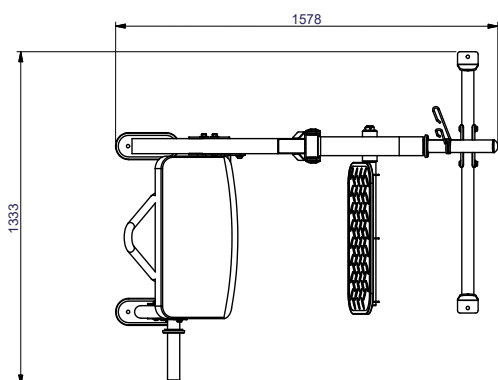

The Steelflex Plate Load PLHE Hip Extension machine will revolutionise the way you train your gluteus, hamstring and quadricep muscles. This machine is designed to emulate natural body movement to optimise the isolation of the targeted muscle groups.

- Olympic weight posts (for use only with olympic weight plates)
- For both commercial and non-commercial use
- **Weight plates not included**

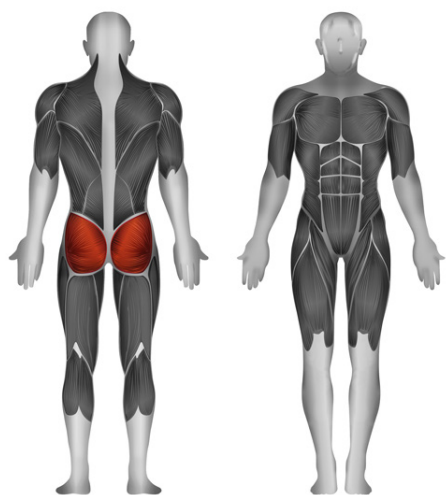

## FEATURES

- 11 gauge steel frame, 6 x 12 cm oval tubing
- Electrostatically applied powder coating
- 50 mm CGPC high density foam upholstery & ergonomic design
- Industrial rated bearings, sealed bearings at all pivot points
- Dipped PVC handle
- Continuous welds at all pivot points
- Natural movement of the body to optimise the isolation of the targeted muscle groups.
- Wide, non-slip platform

## SPECIFICATIONS

- Dimensions: 157.8 x 133.3 x 180.3 cm
- Product weight: 99 kg
- Max. user weight: 120 kg

## WARRANTY: COMMERCIAL AND RESIDENTIAL

- Frame: 15 years
- Bearings: 2 years
- Upholstery & grips: 6 months
- Other parts: 1 year