

PLBP Plateload Bench Press Machine

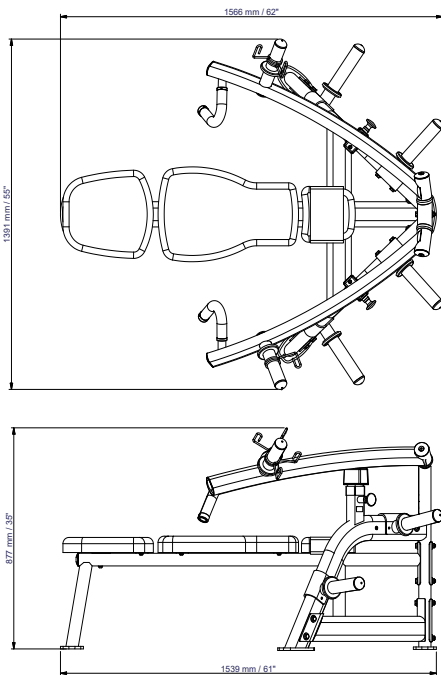

This Steelflex Plate Load PLBP Bench Press machine is designed with great precision to provide a 25° converging pattern providing exceptional range of motion and a natural feel to your workout. The bench press arms can be used together or independently for balanced muscle development.

- Olympic weight posts (for use only with olympic weight plates)
- For both commercial and non-commercial use
- **Weight plates not included**

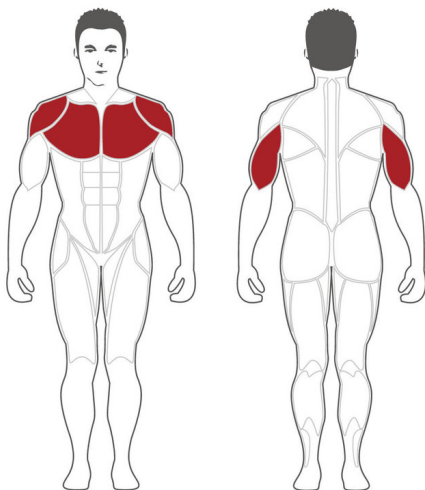

FEATURES

- 11 gauge steel frame, 5 x 10 cm square tubing
- Electrostatically applied powder coating
- Industrial rated bearings, sealed bearings at all pivot points
- 50 mm CGPC high density foam upholstery & ergonomic design
- Continuous welds at all pivot points
- Independent, unilateral arm action for balanced muscle development
- Converging press arm movement for advanced biomechanics
- Independent, unilateral arm action for balanced muscle development

SPECIFICATIONS

Dimensions:	156.6 × 139 × 88 cm
Product weight:	75 kg
Max. user weight:	120 kg

WARRANTY: COMMERCIAL AND RESIDENTIAL

Frame	15 years
Bearings	2 years
Upholstery & grips	6 months
Other parts	1 year