

PLBC Plateload Bicep Curl Machine

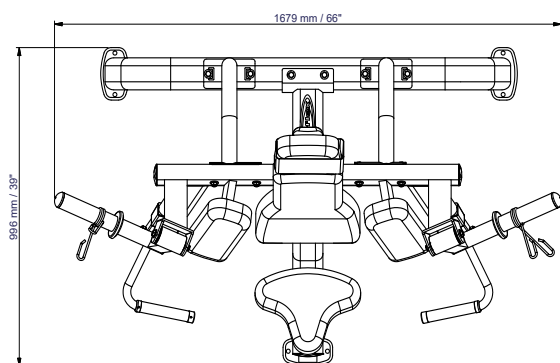

The Bicep Curl Machine Steelflex PlateLoad Line PLBC is a high-quality workout machine for strengthening your biceps. The sturdy, stable structure is coated with electrostatic powder paint which protects it from scratches. The PLBC features quality, high padding on the seat, backrest and armrests, respectively, foam-padded handles and anti-slip legs for better stability during the workout. This exercise machine also features screw covers and fully sealed bearings.

- Olympic weight posts (for use only with olympic weight plates)
- For both commercial and non-commercial use
- **Weight plates not included**

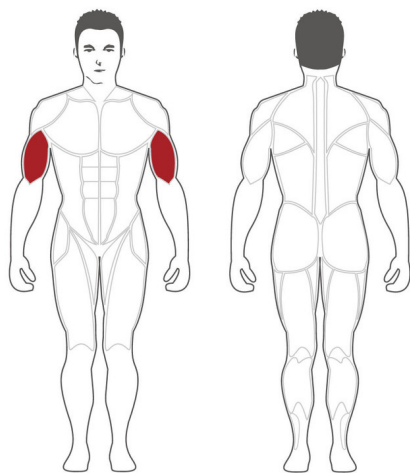

FEATURES

- 11 gauge steel frame, 5 x 10 cm square tubing
- Electrostatically applied powder coating
- Industrial rated bearings, sealed bearings at all pivot points
- 50 mm CGPC high density foam upholstery & ergonomic design
- Continuous welds at all pivot points
- Adjustable seat to fit all size users
- Ergonomically designed biceps curl hand grip positions
- Independent, unilateral arm action for balanced muscle development and advanced biomechanics

SPECIFICATIONS

Dimensions:	168 x 99.6 x 130 cm
Product weight:	67 kg
Max. user weight:	120 kg

WARRANTY: COMMERCIAL AND RESIDENTIAL

Frame	15 years
Bearings	2 years
Upholstery & grips	6 months
Other parts	1 year