

JOONG CHENN INDUSTRY CO., LTD.

Sales Office:

3F28, No.5, Shin-Yi Rd., Sec. 5, Taipei, Taiwan 110 R.O.C.

Tel: 886-2-27209980

Fax:886-2-27229750

www.steelflexfitness.com

PLAC

OWNER'S MANUAL

HARDWARE ILLUSTRATION

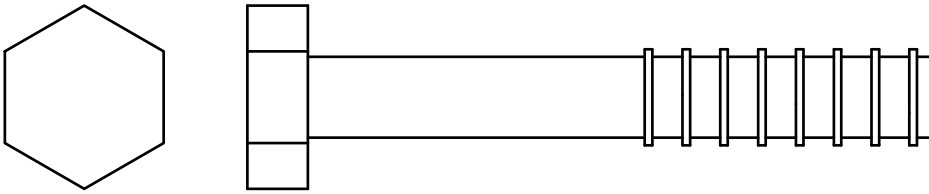

(A1)HEX BOLT 1/2"x3-1/4"L PARTIAL THREAD QTY.2

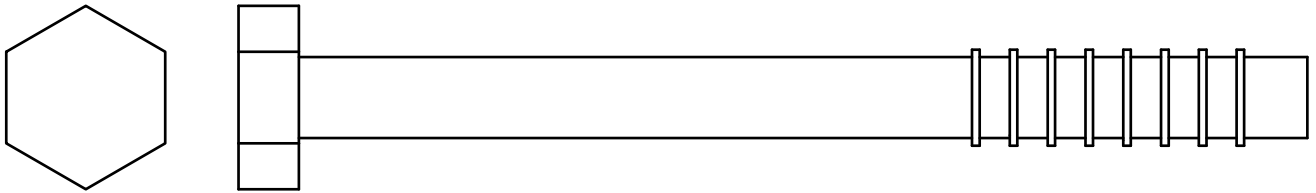

(A2)HEX BOLT 1/2"x5 1/4"L PARTIAL THREAD QTY.4

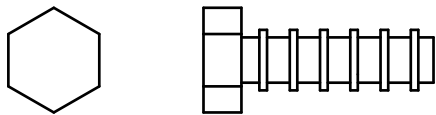

(A3)HEX BOLT 5/6"x1"L PARTIAL THREAD QTY.6

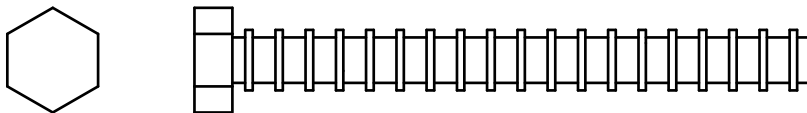

(A4)HEX BOLT 5/16"x3"L PARTIAL THREAD QTY.2

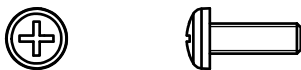

(A5)ROUND ALLEN HEAD M4X12L PARTIAL THREAD QTY.2

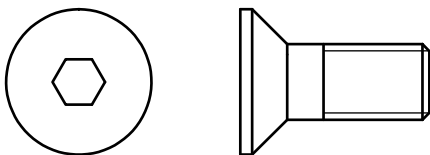

(A6)Co.Noid HEAD BOLT M10X25L PARTIAL THREAD QTY.2

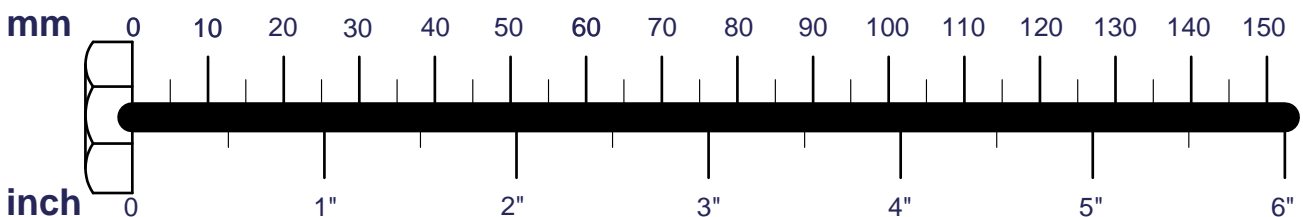

HARDWARE ILLUSTRATION

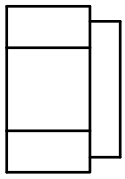

(B1) NYLON LOCK NUT 1/2" QTY.6

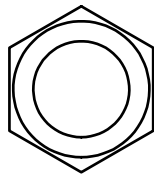

(B2) NYLON LOCK NUT M4 QTY.2



(B3) NYLON LOCK NUT M12 QTY.2

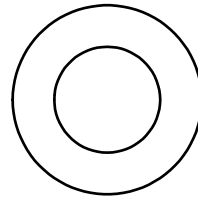
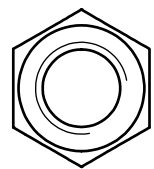
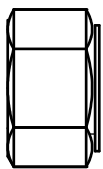

(C1) 1/2" (I.D.) FLAT WASHER Ø25 QTY.8



(C2) 1/2" (I.D.) FLAT WASHER Ø34 QTY.6

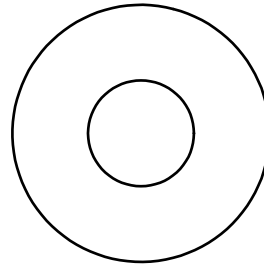

(C3) 5/16" (I.D.) FLAT WASHER Ø24 QTY.8

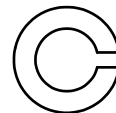
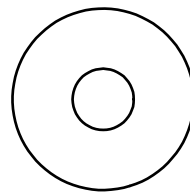

(C4) 5/16" SPRING WASHER QTY.8

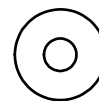
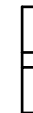

(C5) M4 (I.D.) FLAT WASHER Ø12 QTY.2

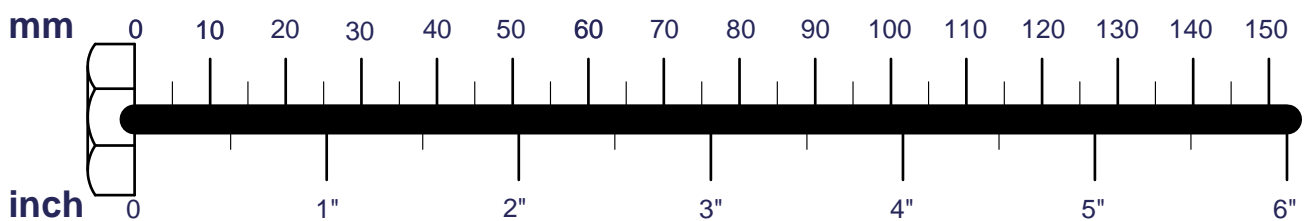

HARDWARE ILLUSTRATION

- D1. Ø1" SHAFT COLLAR(8130-024)-----[2PCS]
- D2. 1"X2" END CAP(9211-009)-----[2PCS]
- D3. 25x50 End Cap (9211-086)-----[1PCS]
- D4. □45 End Cap (9211-091)-----[1PCS]

- D6. 2" Nylon Washer (9214-001)-----[4PCS]
- D7. 3" Nylon Washer (9214-008)-----[2PCS]
- D8. Ø90XØ50X10T RUBBER DOUNT(9310-016)-----[4PCS]
- D9. Ø58X116X29T RUBBER PAD(9310-057)-----[1PCS]
- D10. Olympic Spring Collars(OC-06)-----[1PCS]
- D11. Ø29X14H Rubber Dount(9212-042)-----[2PCS]
- D12. IMMOBILE COVER(9211-121)-----[8PCS]
- D13. Protector Strip(9440-202)-----[2PCS]
- D14. Ø50 CAP COVER(8130-131)-----[2PCS]
- D15. 50X100X3T End Cap (9211-180)-----[2PCS]

D1



D2



D3



D4



D6



D7



D8



D9



D10



D11



D12

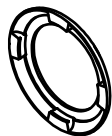

D13

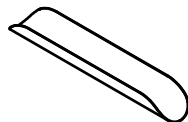

D14



D15



PARTS ILLUSTRATION SHEET

A[2PCS]

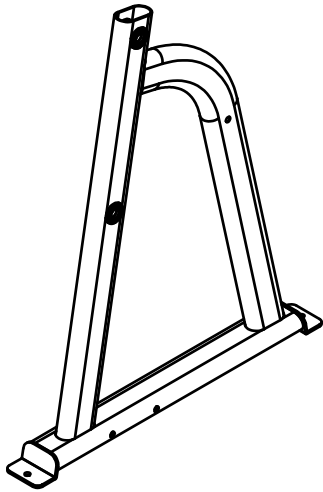

B[1PCS]

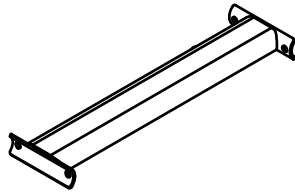

C[1PCS]

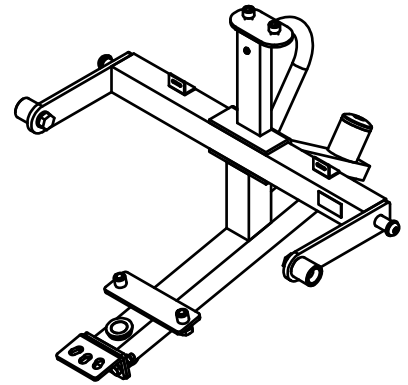

D[1PCS]

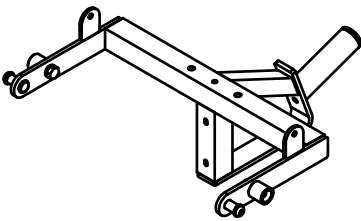

E[1PCS]

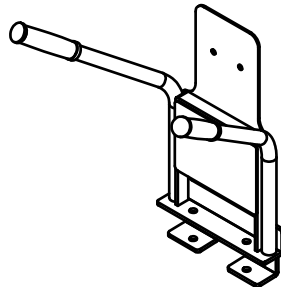

F[2PCS]
6630-001

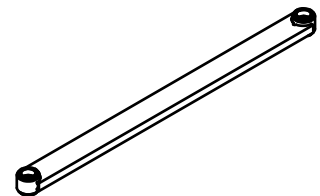

G[1PCS]
6640002-26
Ø1"X2.5TX565L

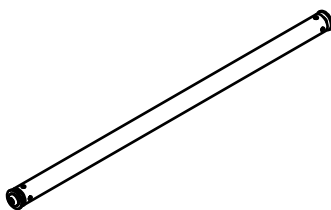

H[1PCS]
9420-142

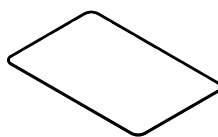

I[2PCS]
6640005-26

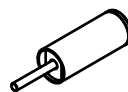

J[1PCS]
6650-001

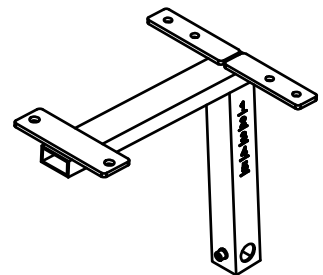

PARTS ILLUSTRATION SHEET

K[1PCS]

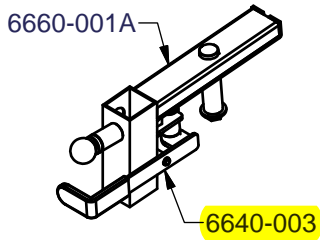

L[1PCS]
6640006-26
Ø1"X2.5TX400L

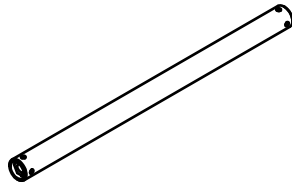

M[4PCS]
8260-071

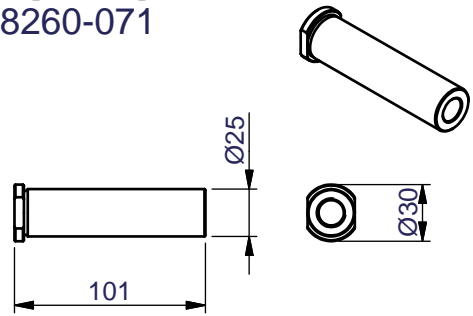

O[2PCS]
8343-163

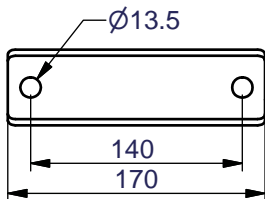
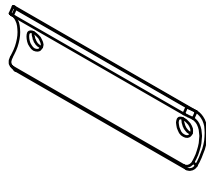

Q[1PCS]
9111-061

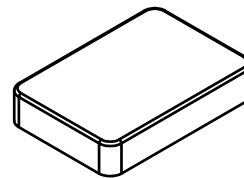

P[1PCS]
8360-200

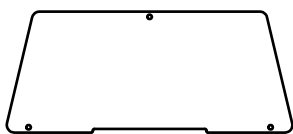

U[1PCS]
9131-018

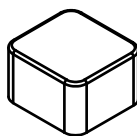

R[1PCS]
9121-058

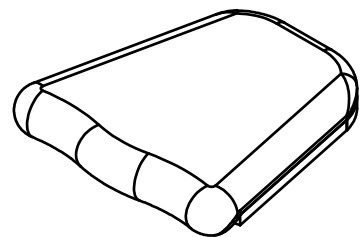

S[1PCS]
9161-051

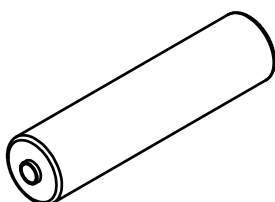

T[2PCS]
9161-052

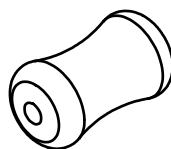

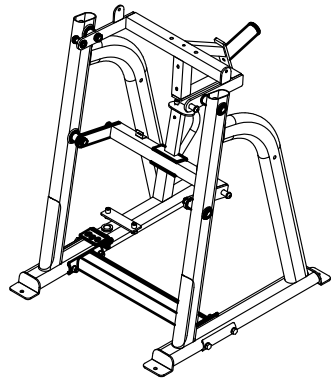

Above shows STEP 1
assembled and completed

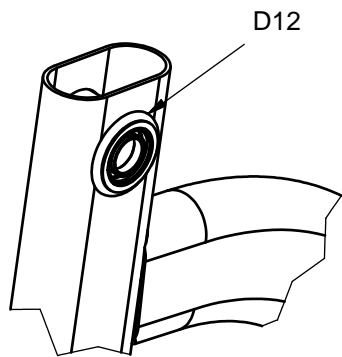

DETIAL VIEW

When assembling C, please follow the order.
Stick the M through the hole on the right side of the main frame.
After C has been fixed on right hand side,
follow the same step to tighten the other side of C with M.

When assembling D, please follow the order.
Stick the M through the hole on the right side of the main frame.
After D has been fixed on right hand side,
follow the same step to tighten the other side of D with M.

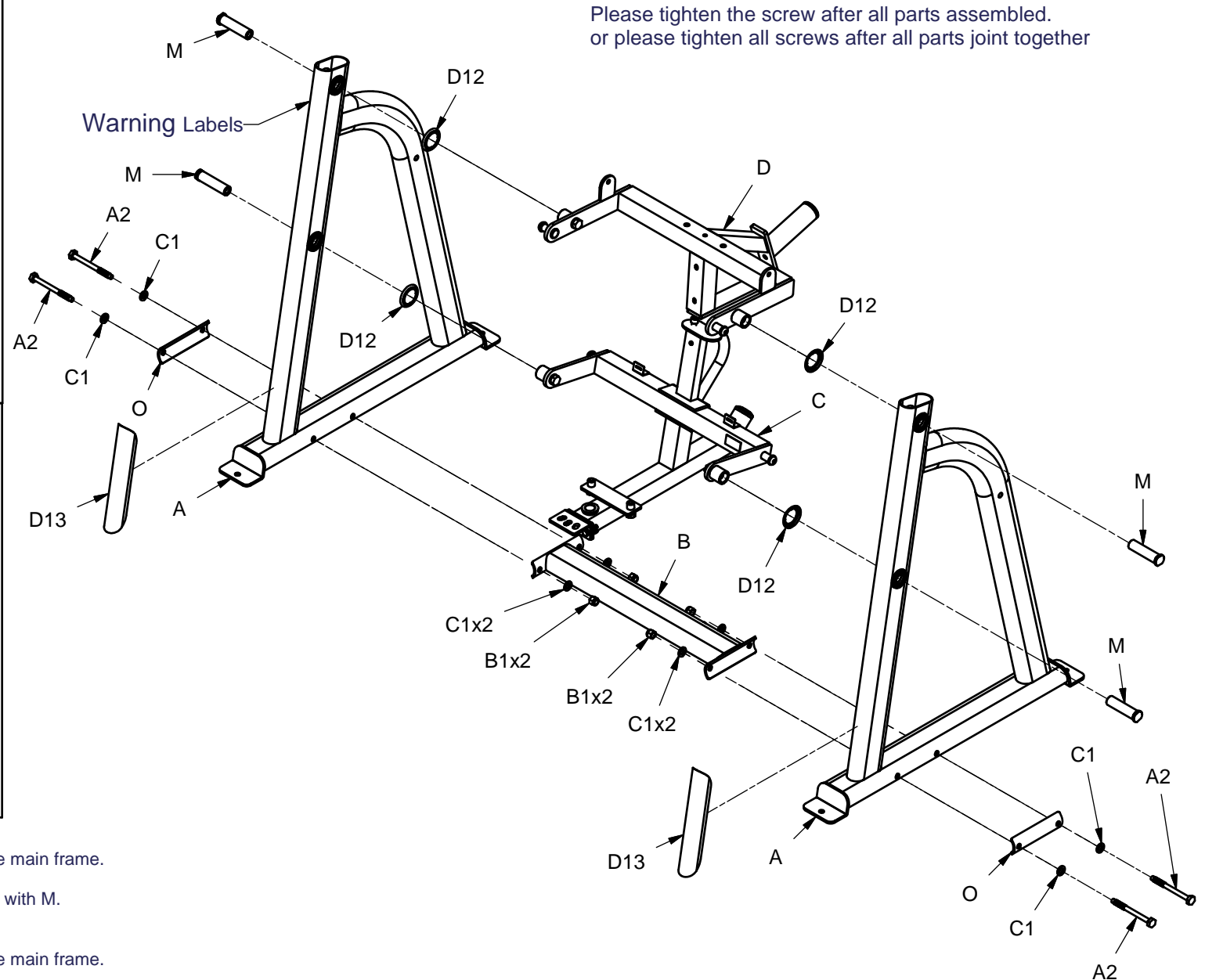

Please tighten the screw after all parts assembled.
or please tighten all screws after all parts joint together

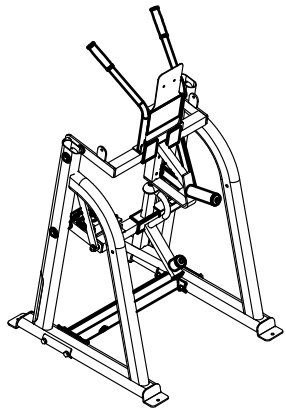

Above shows STEP 2 assembled and completed

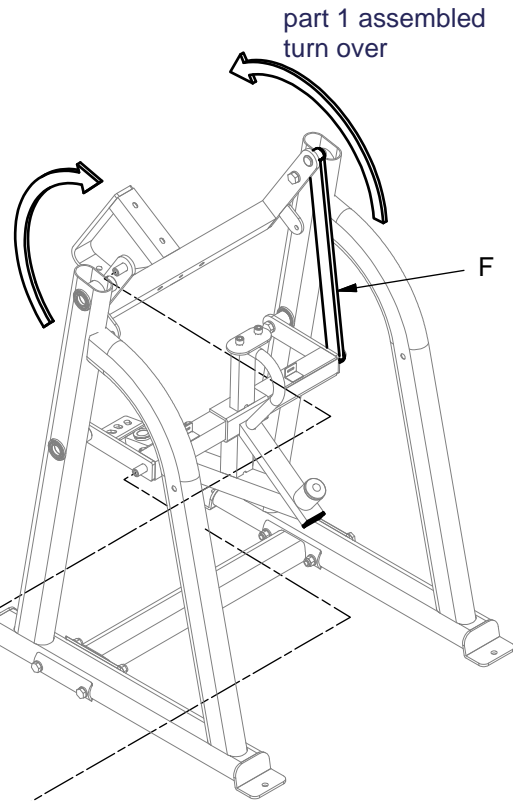

1/2" WASHER Ø25
1/2"X3/4"L
ROUND BOLT

1/2" WASHER Ø25
1/2"X3/4"L
ROUND BOLT

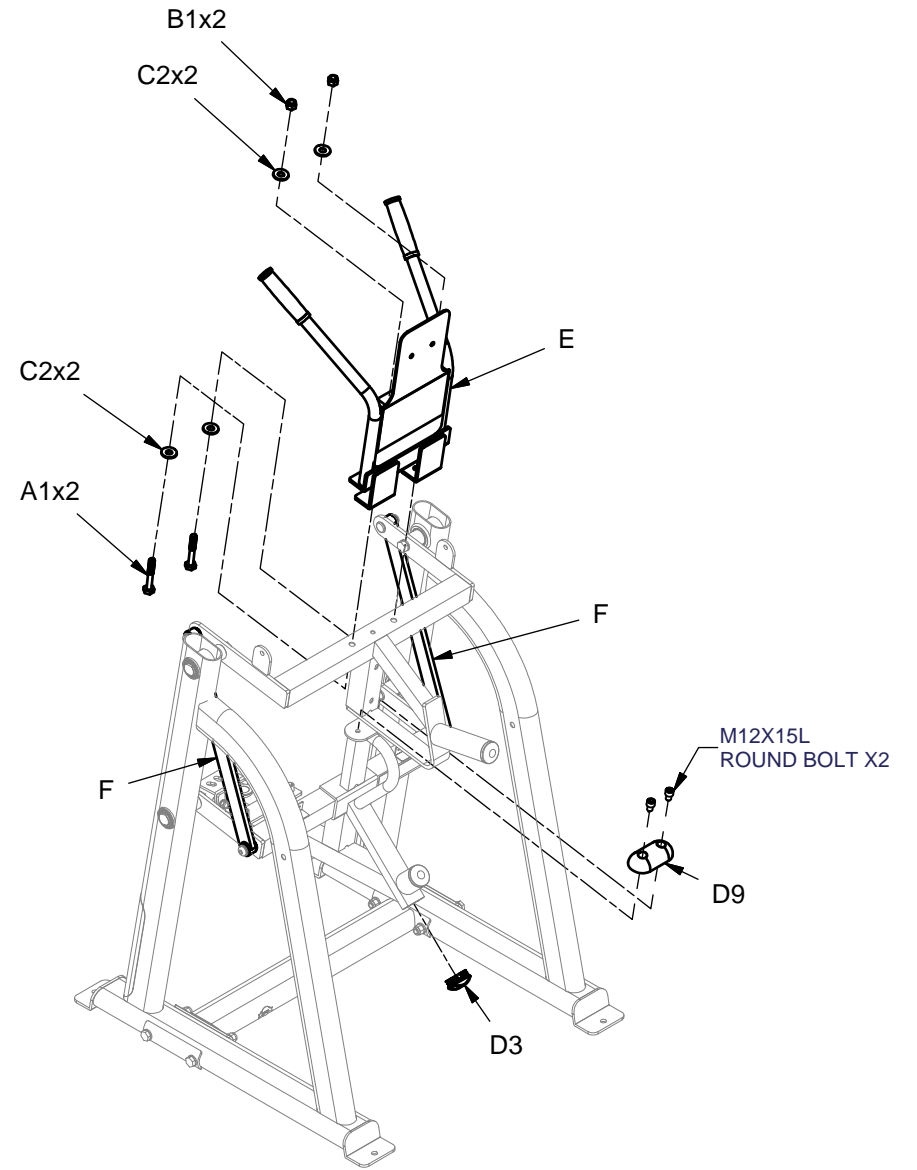

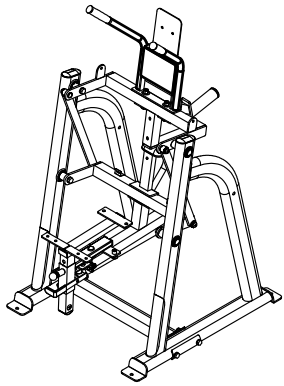

Above shows STEP 3 assembled and completed

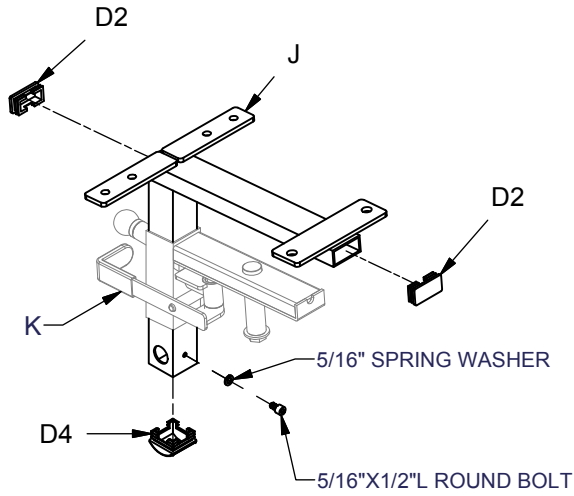

Figure 1

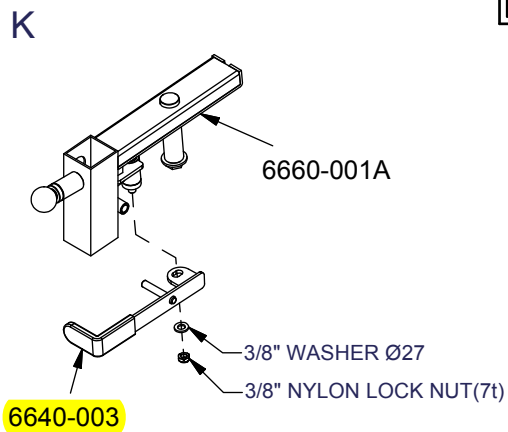
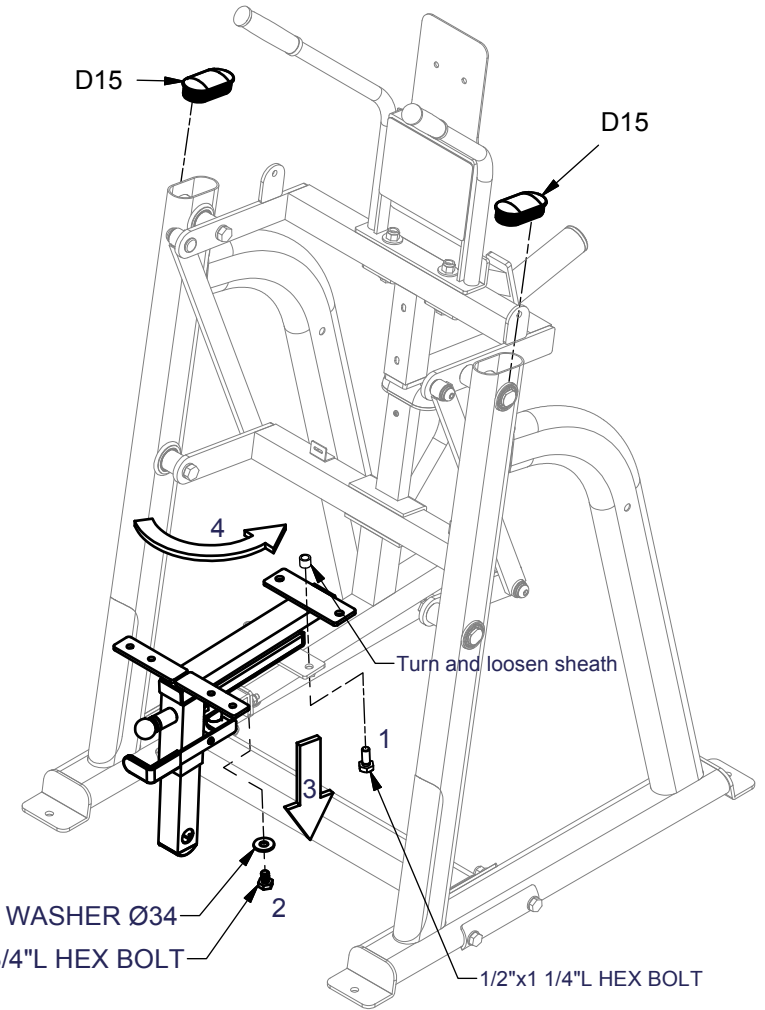
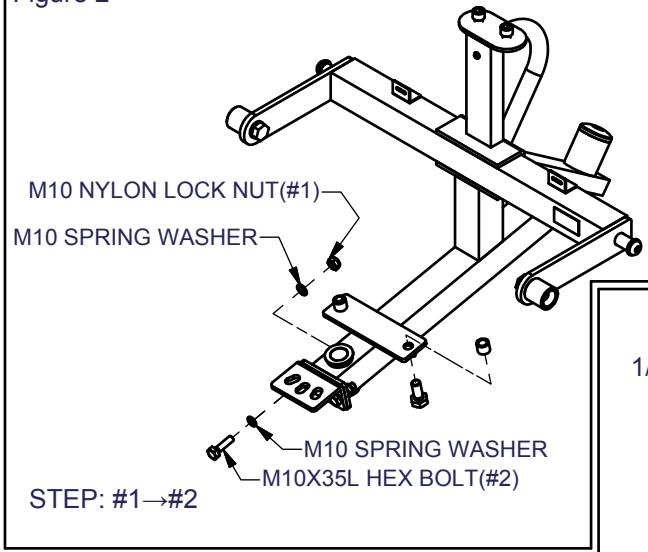
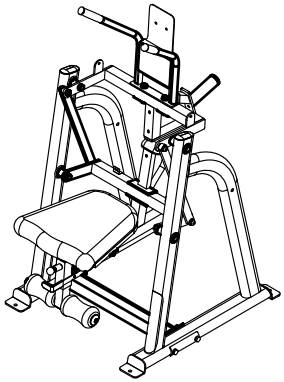

Figure 2



STEP: 1→2→3→4→1→2
tighten all screws as Figure 2
#2→#1



Above shows STEP 4
assembled and completed

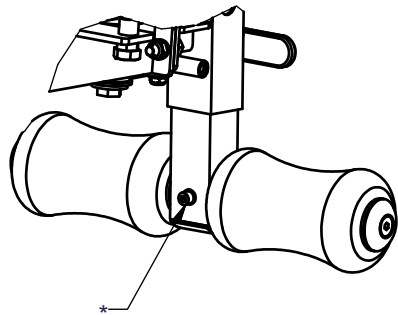

*:NEED TO LOOSEH BOTH ALLEN HEAD BOLT
IN ORDER TO REMOVE SHAFT

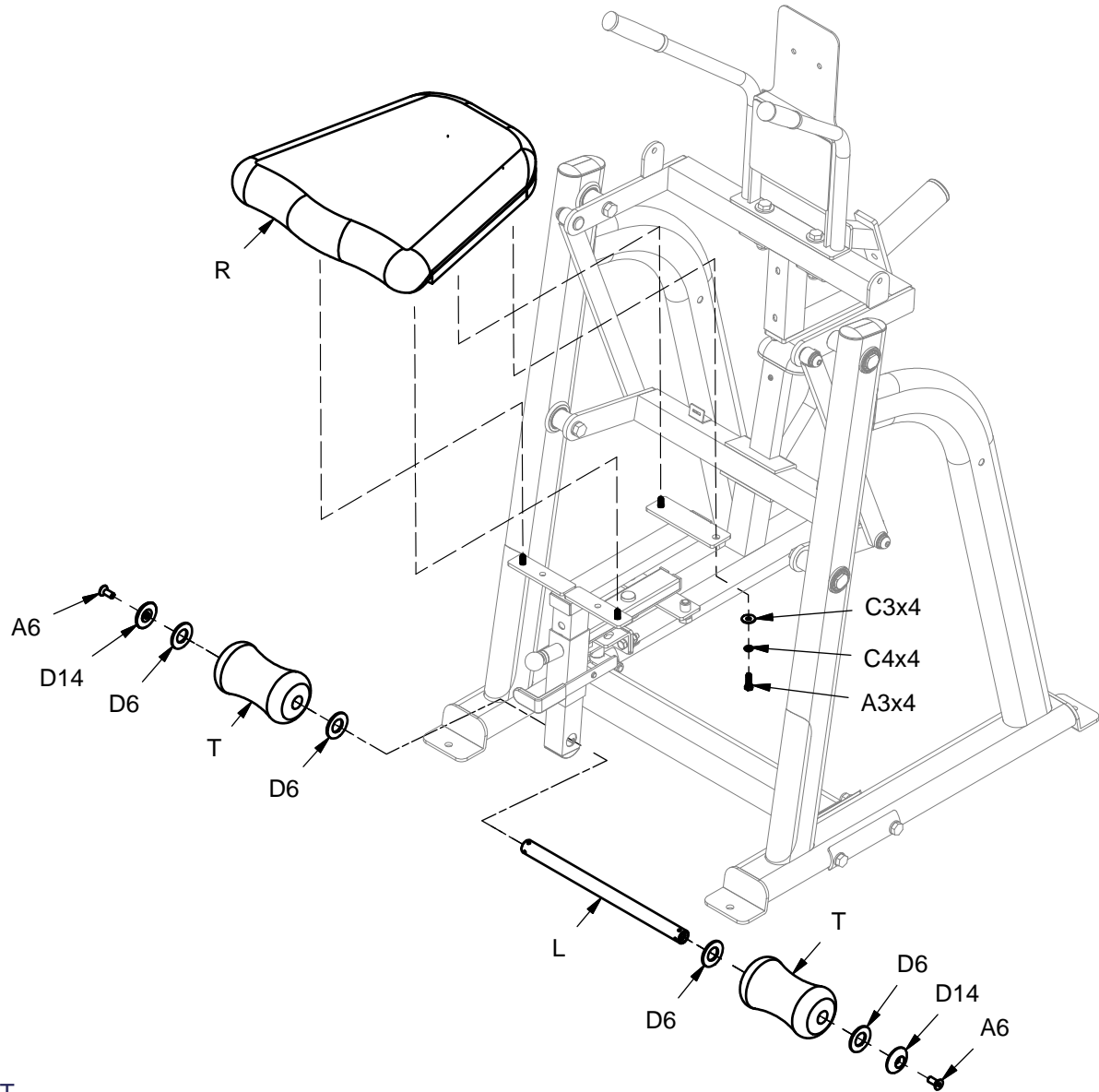

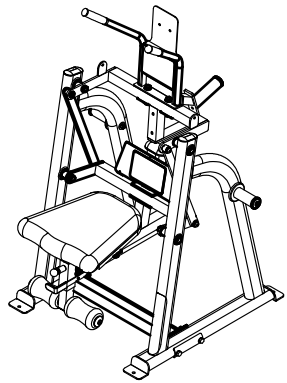

Above shows STEP 5 assembled and completed

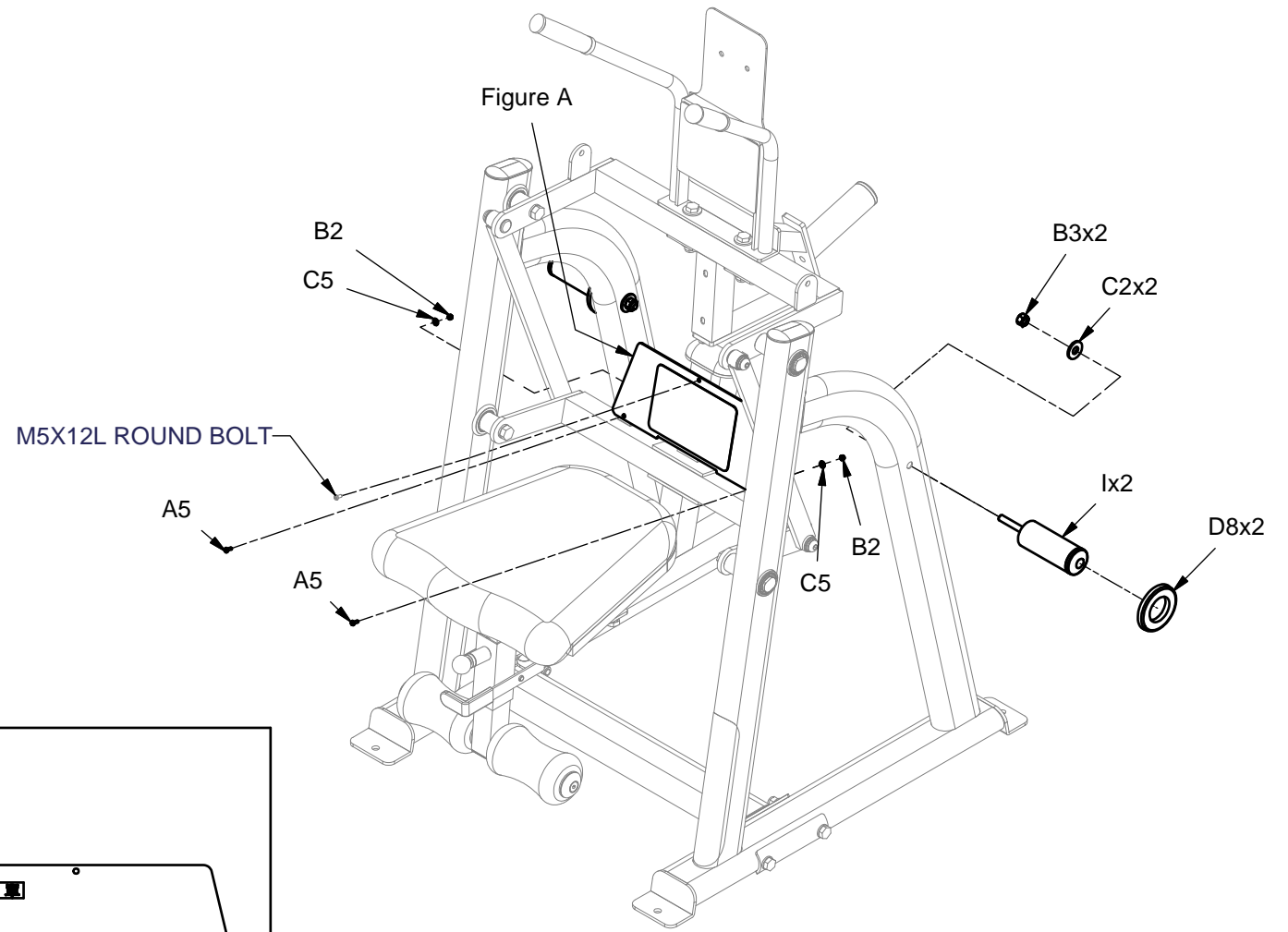
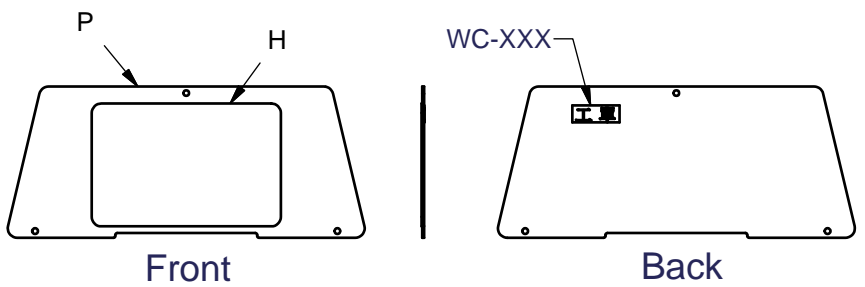
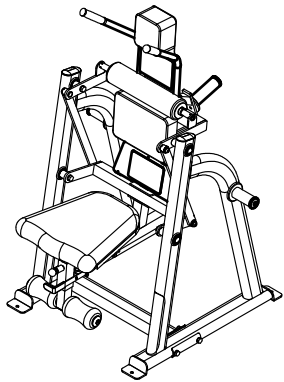

Figure A





Above shows STEP 6 assembled and completed

