

**MEGA POWER**

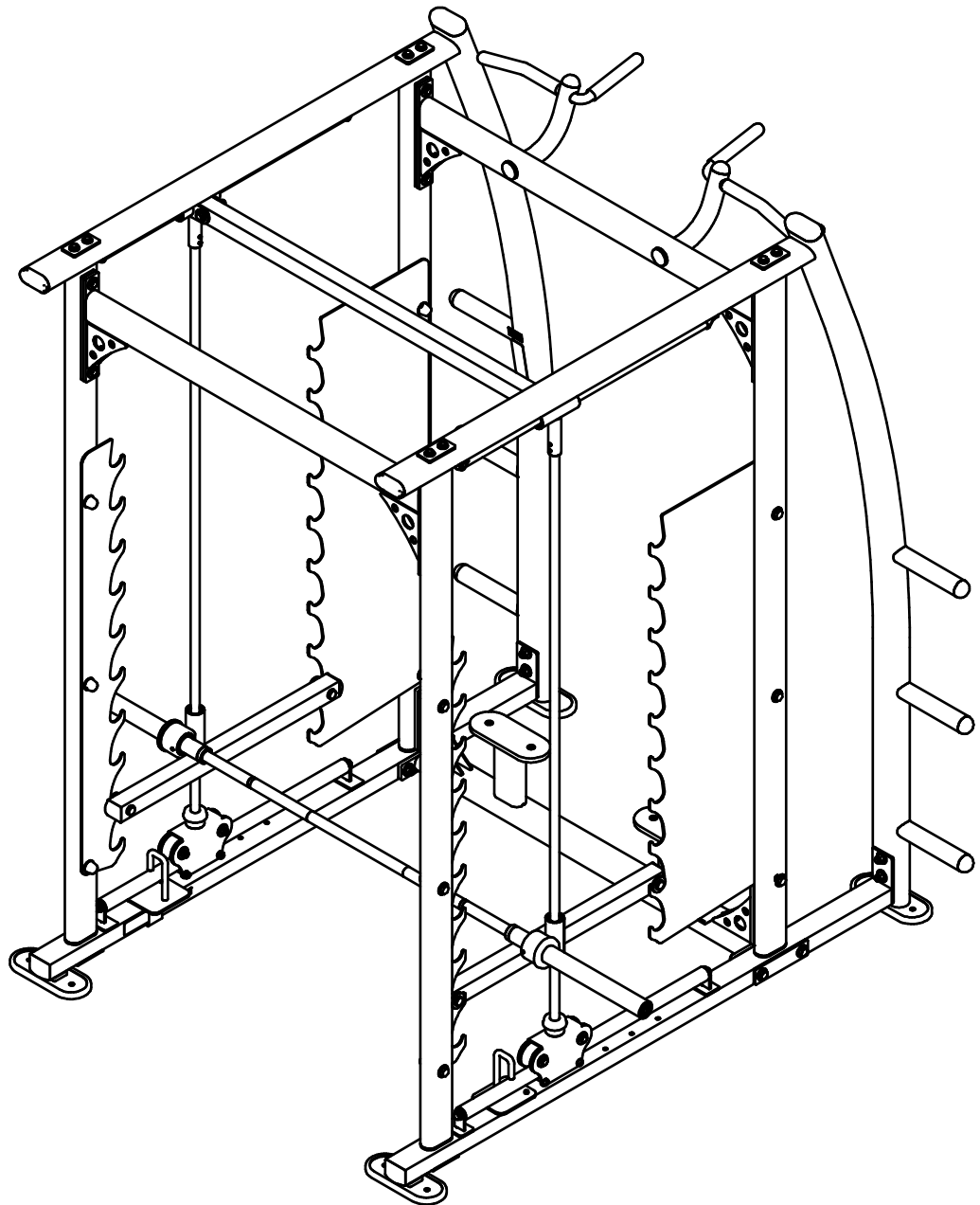

**Steelflex**

JOONG CHENN INDUSTRY CO., LTD.

Sales Office:

3F28, No.5, Shin-Yi Rd., Sec. 5, Taipei, Taiwan 110 R.O.C.

Tel: 886-2-27209980

Fax: 886-2-27229750

[www.steelflexfitness.com](http://www.steelflexfitness.com)

**M3DSM.1 OWNER'S MANUAL**

# M3DSM ASSEMBLY INSTRUCTIONS

## HARDWARE ILLUSTRATION

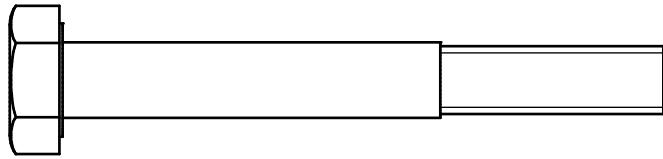
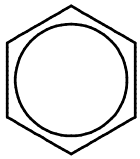

(A2)HEX BOLT M10X80L PARTIAL THREAD QTY.2

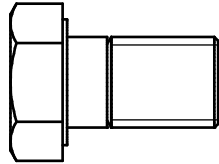
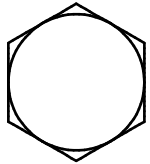

(A5)HEX BOLT M12X20L PARTIAL THREAD QTY.8

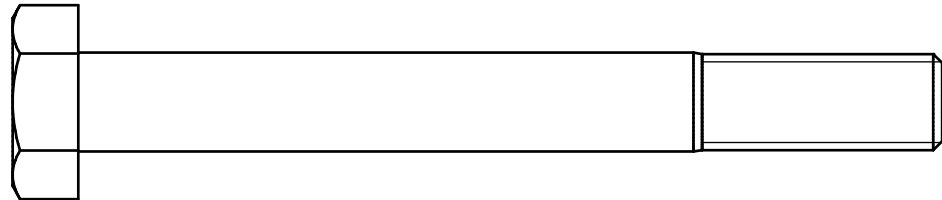
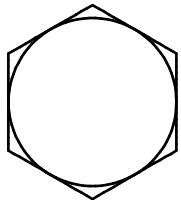

(A7)HEX BOLT 1/2"X4-1/2"L PARTIAL THREAD QTY.4

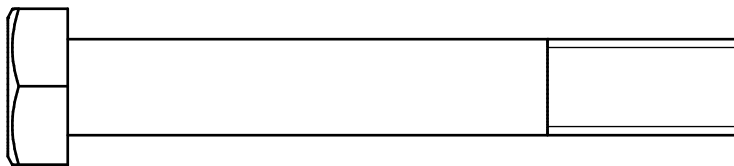
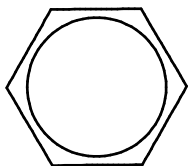

(A8)HEX BOLT 1/2"X12TX3-1/2"L PARTIAL THREAD QTY.6

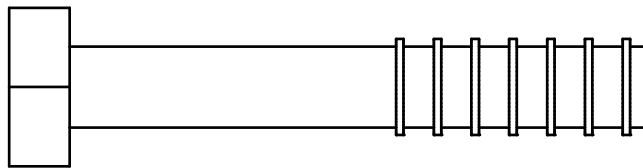
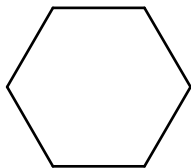

(A9)HEX BOLT 1/2"X3"L PARTIAL THREAD QTY.12

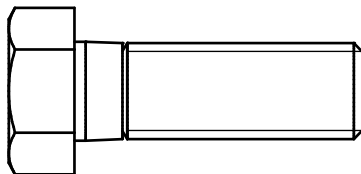
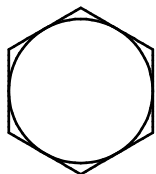

(A10)HEX BOLT 1/2"X1-1/2"L PARTIAL THREAD QTY.10

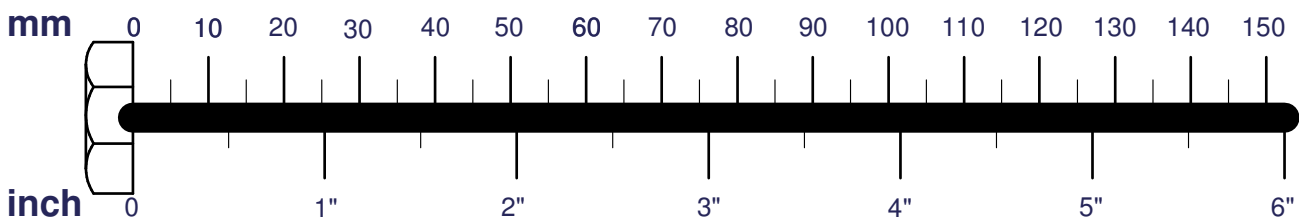

# M3DSM ASSEMBLY INSTRUCTIONS

## HARDWARE ILLUSTRATION

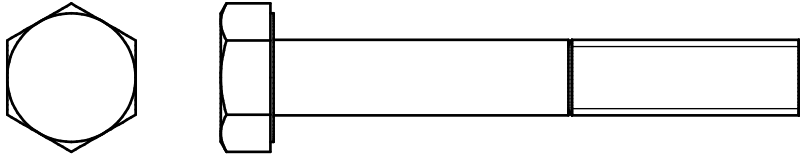

(A13)HEX BOLT M10X70L PARTIAL THREAD QTY.16

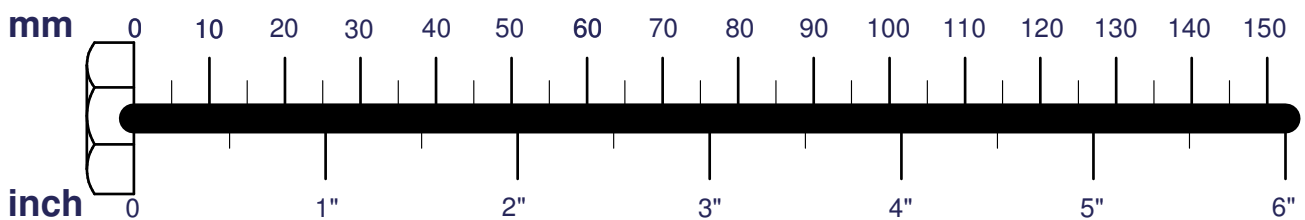

# M3DSM ASSEMBLY INSTRUCTIONS

## HARDWARE ILLUSTRATION

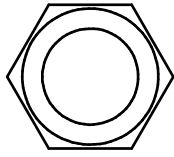

(B1) NYLON LOCK NUT 1/2" QTY.22

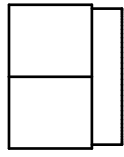

(C4) 1/2" BLOT CAP (9212-024) QTY.12

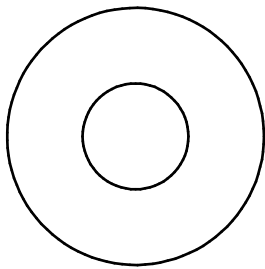
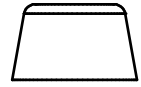
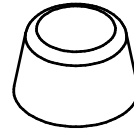

(C1) 1/2"(I.D.) FLAT WASHER Ø34 QTY.42

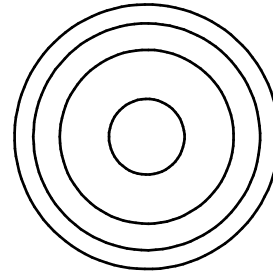
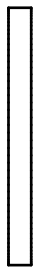

(C5) 1/2"(I.D.) CONICAL WASHER QTY.12

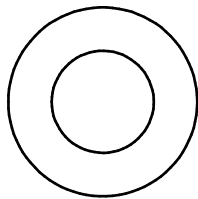

(C2) M12(I.D.) FLAT WASHER Ø25 QTY.4

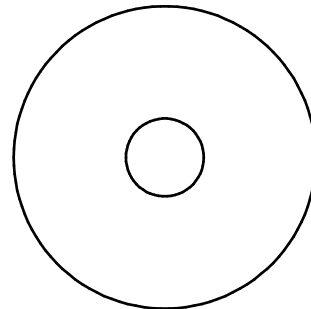

(C6) M10(I.D.) FLAT WASHER Ø40 QTY.2

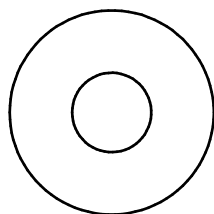
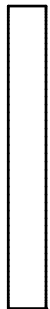

(C3) M10(I.D.) FLAT WASHER Ø27 QTY.16

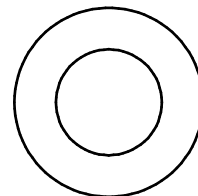
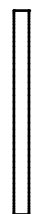

(C7) 1/2"(I.D.) FLAT WASHER Ø25 QTY.4

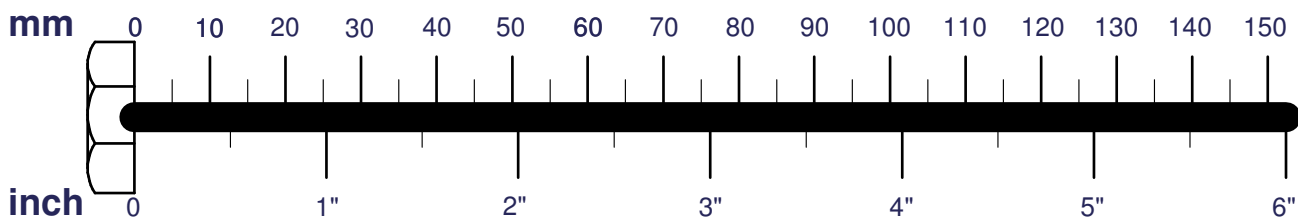

# M3DSM ASSEMBLY INSTRUCTIONS

## HARDWARE ILLUSTRATION

D1. Ø50 End Plug (9211-020)	-----	[2PCS]
D2. Ø50 End Plug (9211-074)	-----	[8PCS]
D3. 50X75 End Plug (9211-084)	-----	[2PCS]
D4. 58X116 End Plug (9211-112)	-----	[2PCS]
D5. 50X100 End Plug (9211-114)	-----	[2PCS]
D6. Ø2.5" Rubber Dount (9310-012)	-----	[2PCS]
D7. Ø90 Rubber Dount (9310-016)	-----	[2PCS]
D8. Rubber Pad (9310-075)	-----	[6PCS]
D10. □50 End Plug (9211-087)	-----	[4PCS]

D1

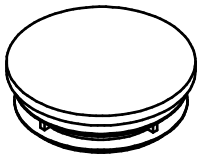

D2

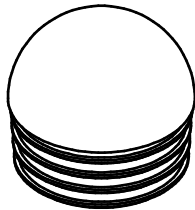

D3

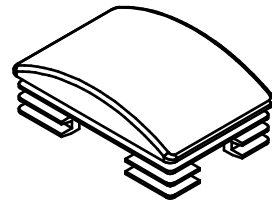

D4

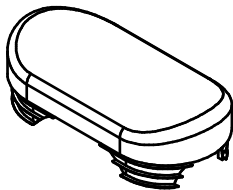

D5

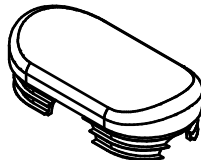

D6

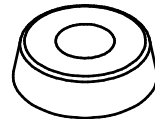

D7

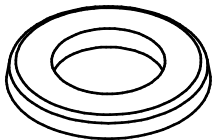

D8

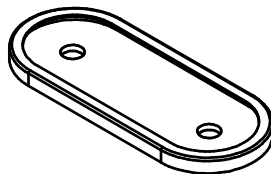

D10

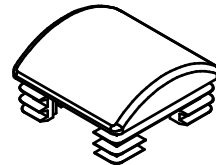

# M3DSM ASSEMBLY INSTRUCTIONS

## PARTS ILLUSTRATION SHEET

A1[1PCS]

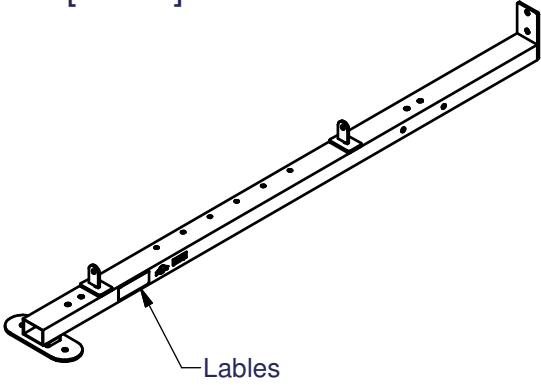

B1[1PCS]

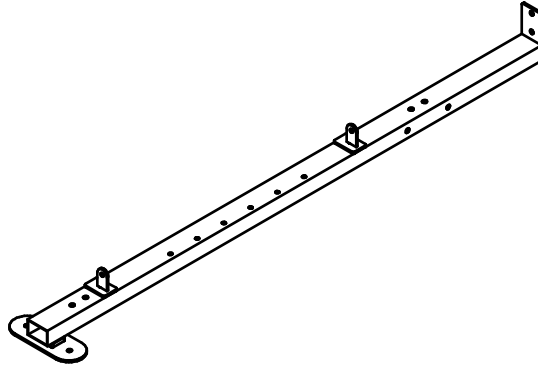

C1[1PCS]

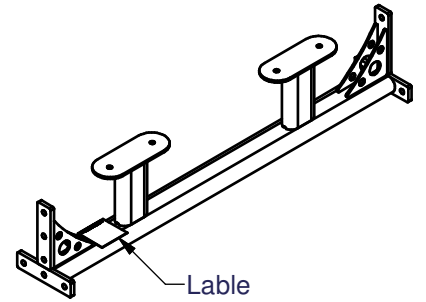

D1[1PCS]

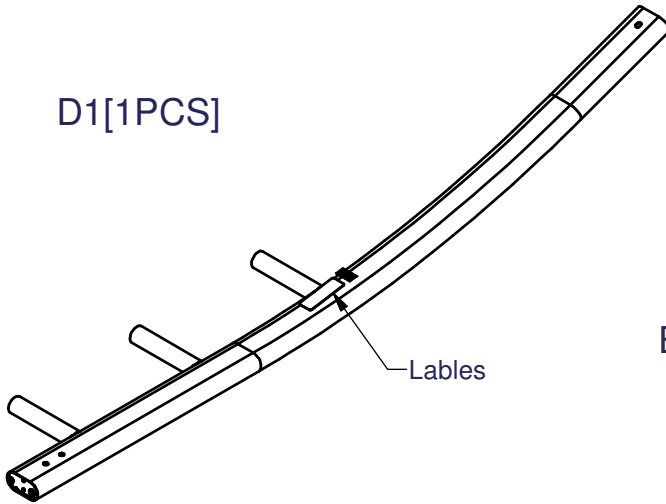

E1[1PCS]

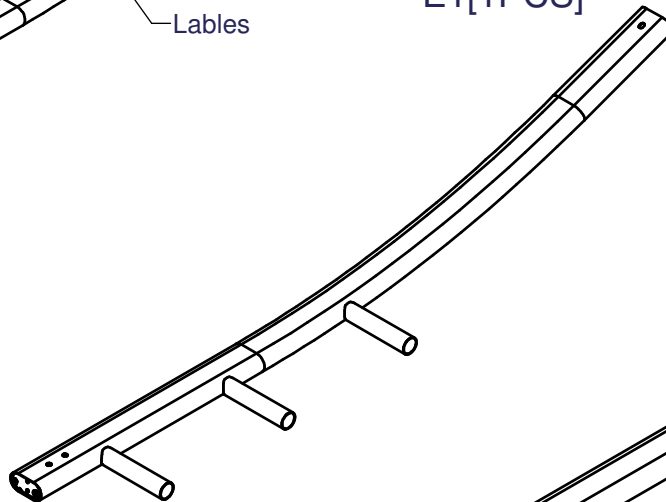

F1[2PCS]

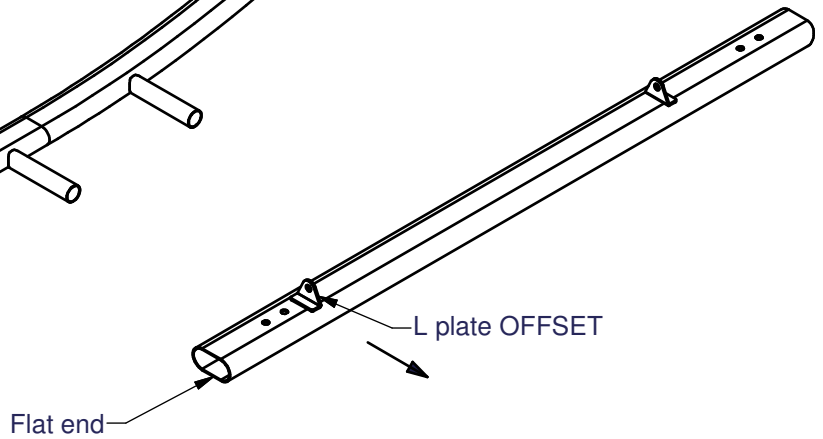

# M3DSM ASSEMBLY INSTRUCTIONS

## PARTS ILLUSTRATION SHEET

G1[1PCS]

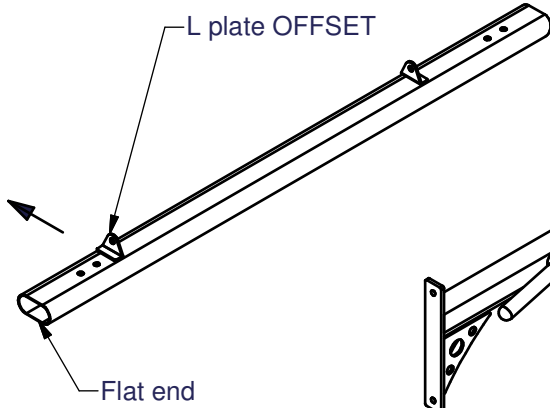

H1[1PCS]

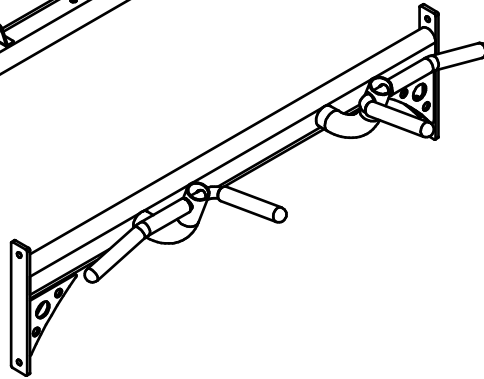

I1[1PCS]

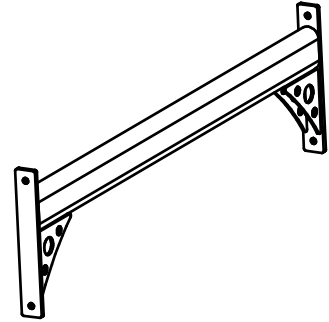

J[2PCS]

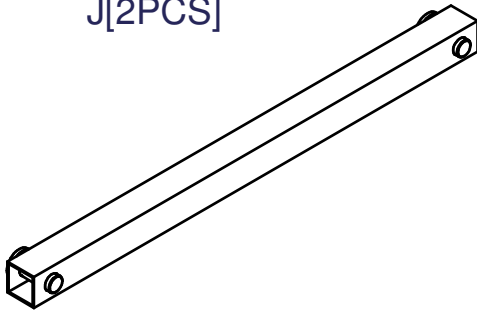

K[1PCS]

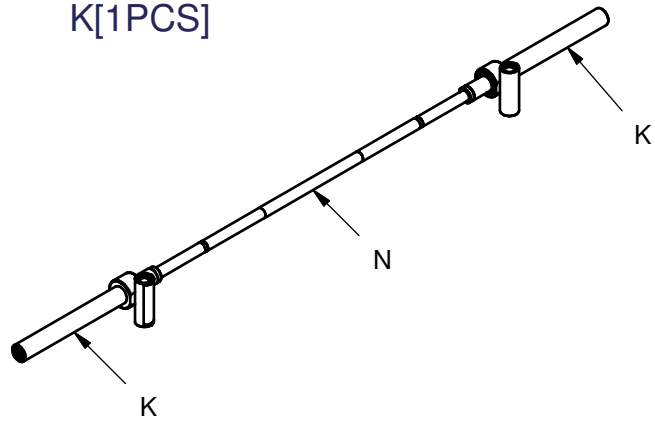

L1[2PCS]

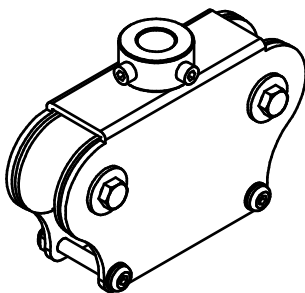

M[2PCS]

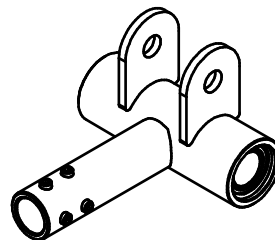

P[2PCS]  
8313-144

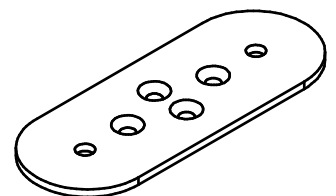

# M3DSM ASSEMBLY INSTRUCTIONS

## PARTS ILLUSTRATION SHEET

Q[1PCS]  
9420-079

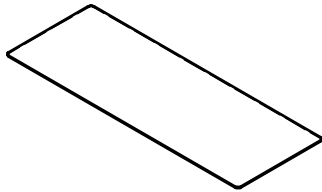

R1[2PCS]  
8343-276

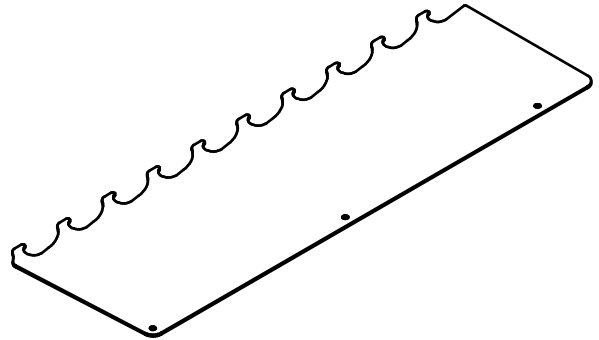

S1[2PCS]  
8343-277

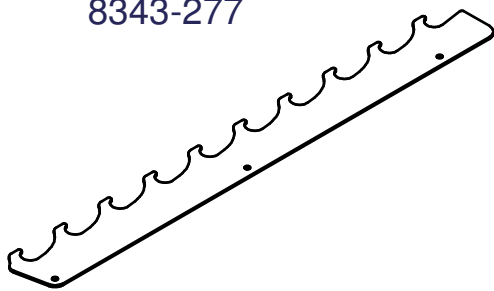

T[2PCS]  
8280-024  
Ø40X926L

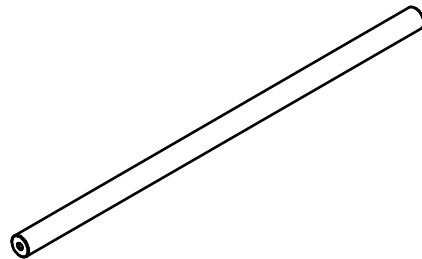

U[2PCS]  
8280-025  
Ø25X1970L

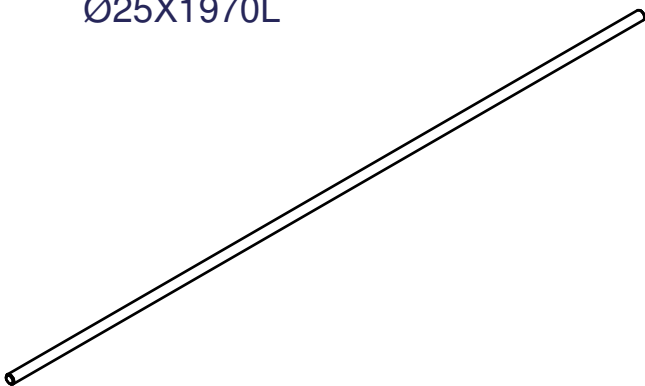

V[2PCS]  
8280-026  
Ø25X926L

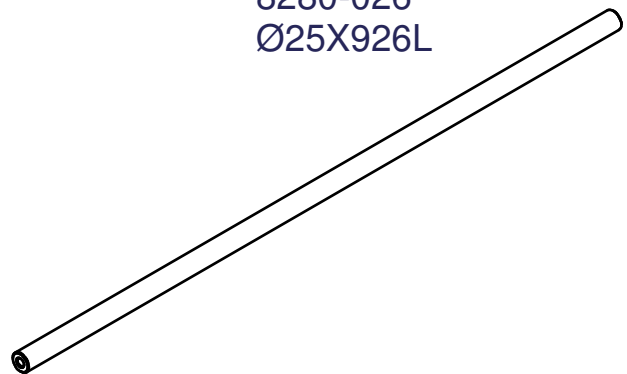



# M3DSM ASSEMBLY INSTRUCTIONS

## PARTS ILLUSTRATION SHEET

X[1PCS]

□50X1315L

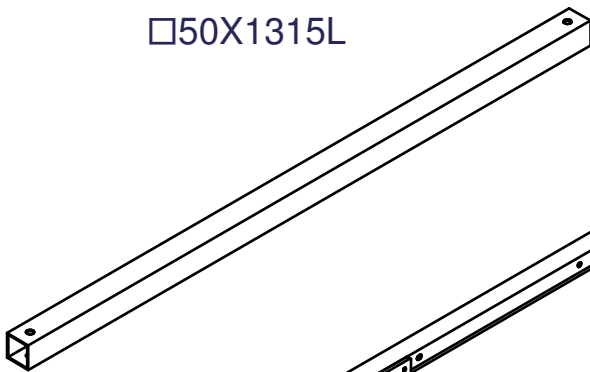

Y[2PCS]

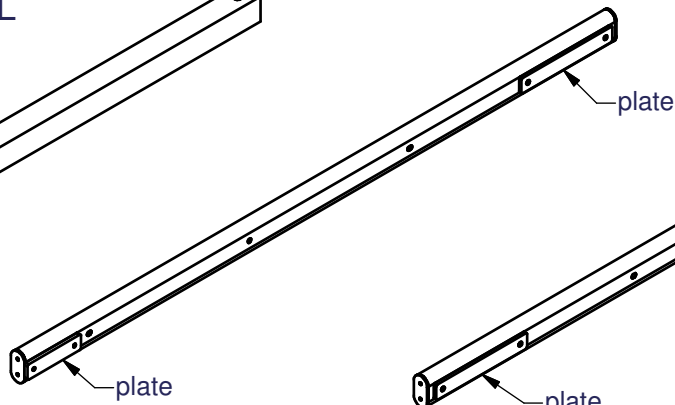

Z[2PCS]

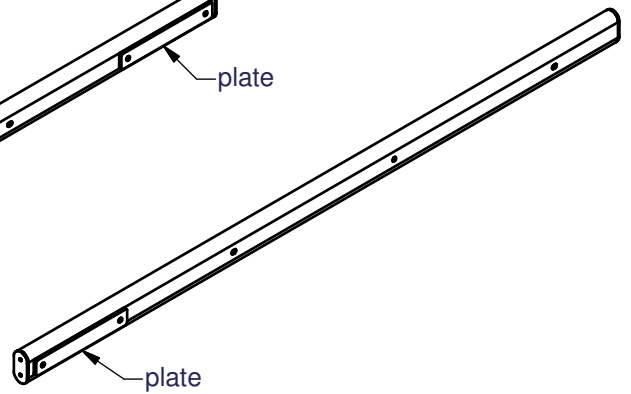

AA[1PCS]

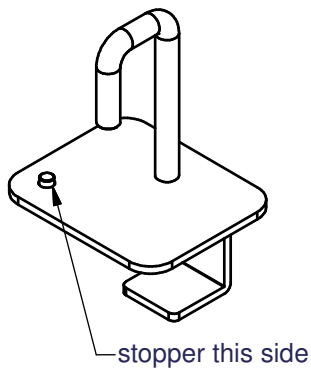

AB[1PCS]

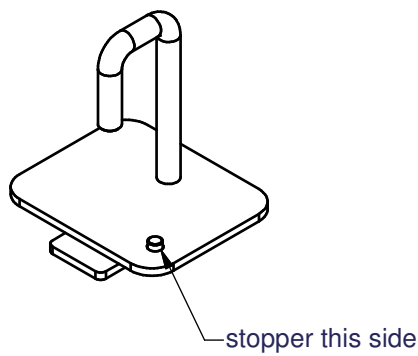

AC[4PCS]  
8312-049

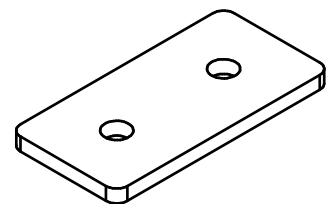

AD[2PCS]  
8312-077

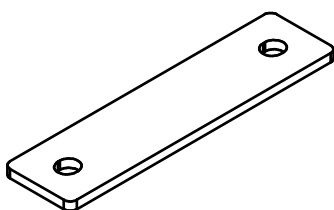

AE[4PCS]  
8313-204

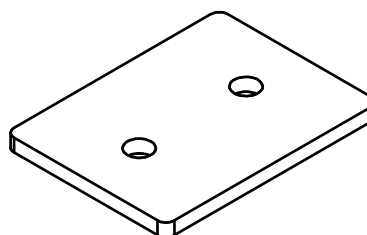

# M3DSM ASSEMBLY INSTRUCTIONS

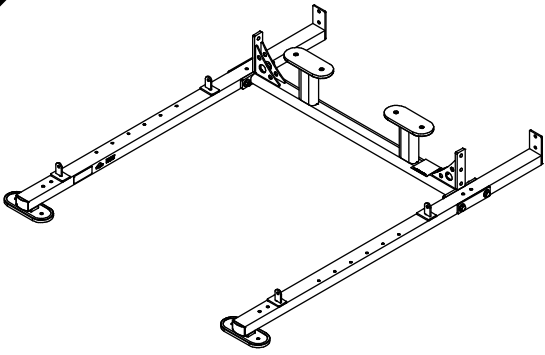

Above shows STEP 1  
assembled and completed

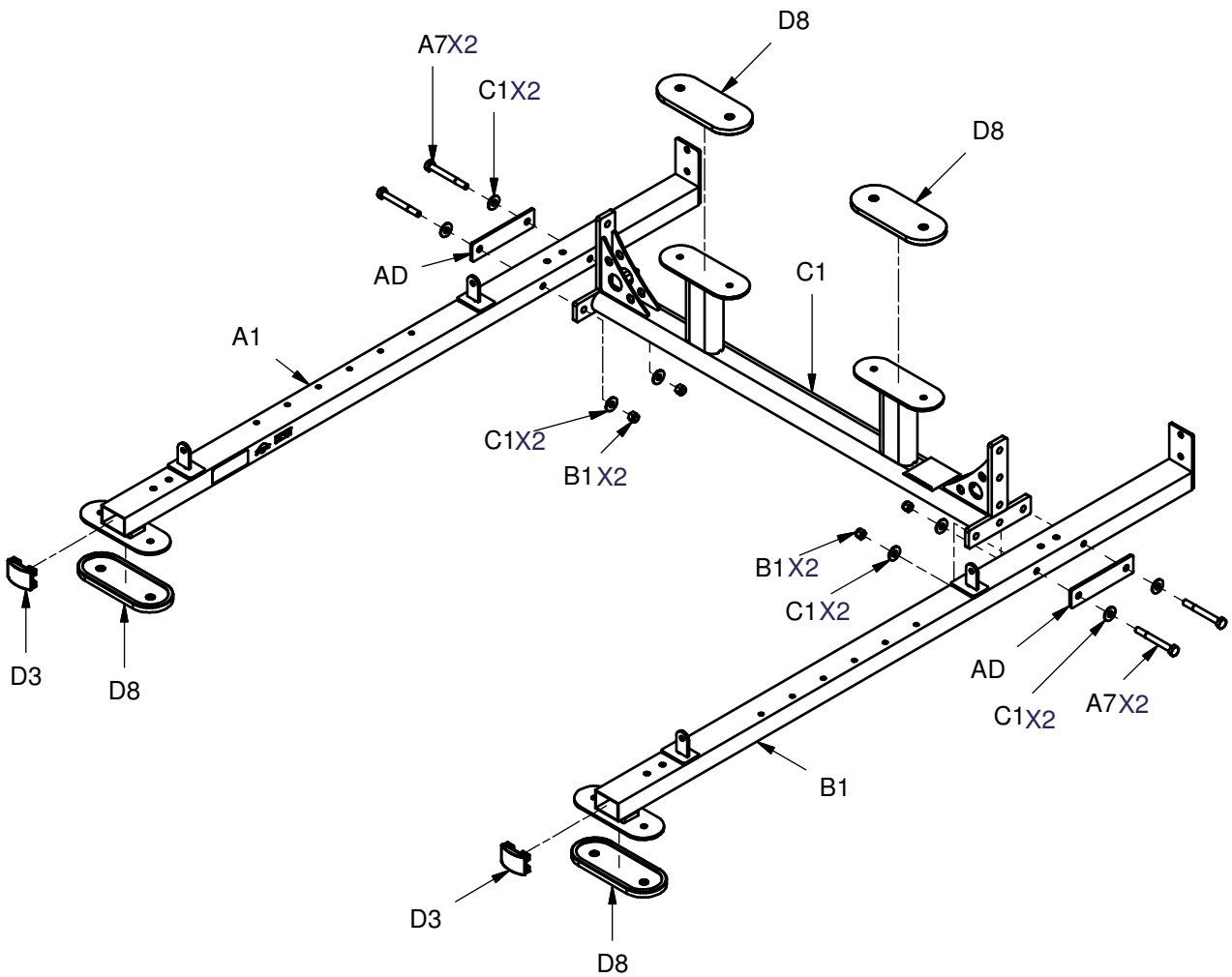

# M3DSM ASSEMBLY INSTRUCTIONS

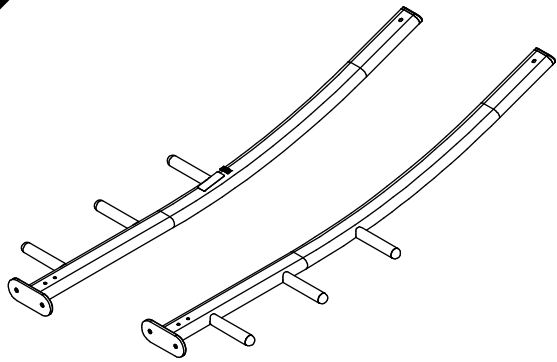

Above shows STEP 2  
assembled and completed

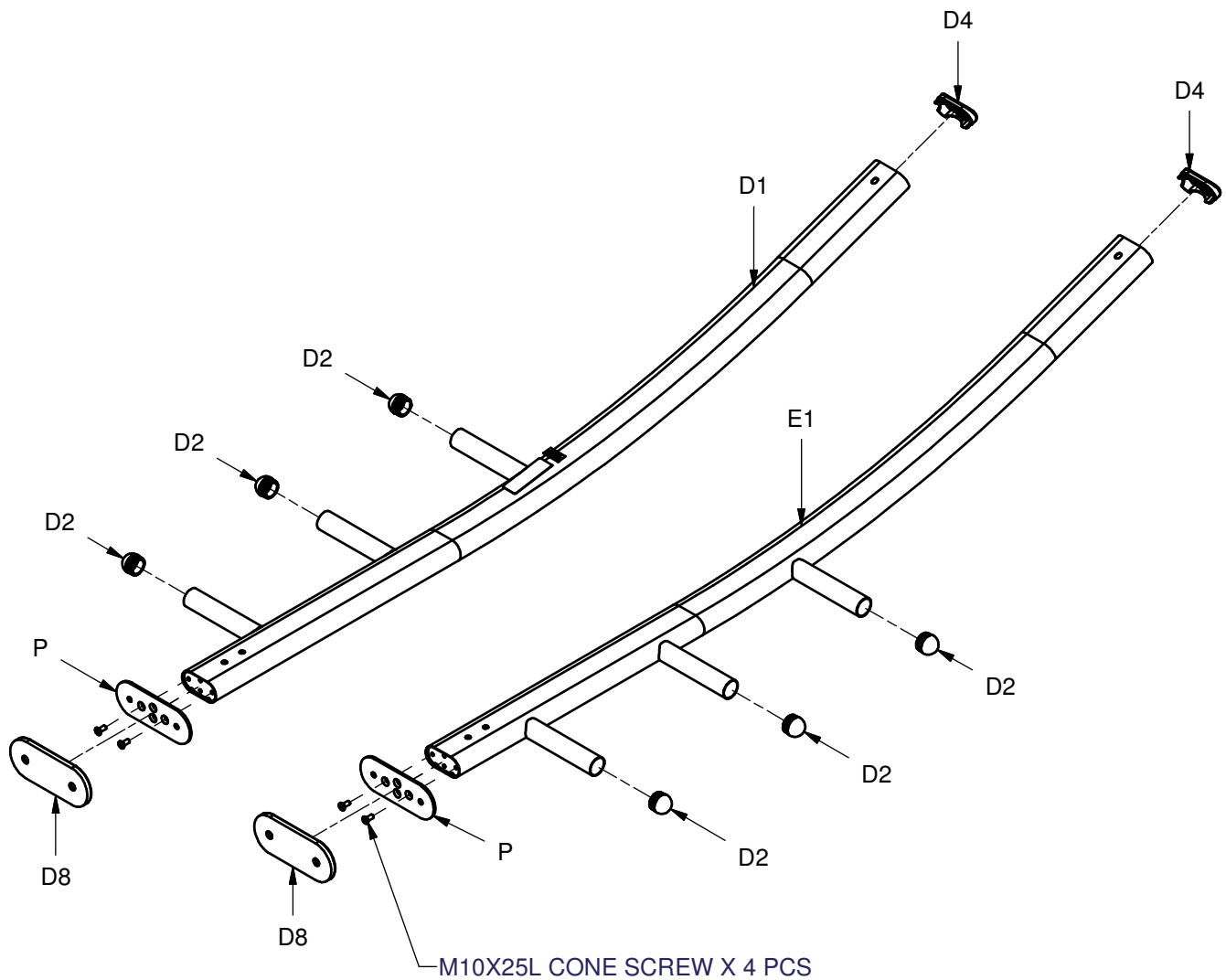

# M3DSM ASSEMBLY INSTRUCTIONS

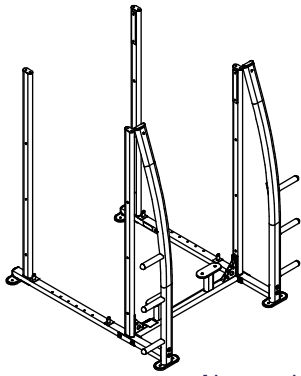

Above shows STEP 3 assembled and completed

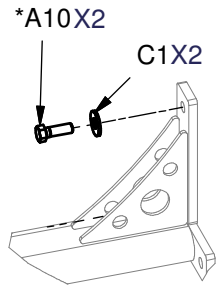

View A

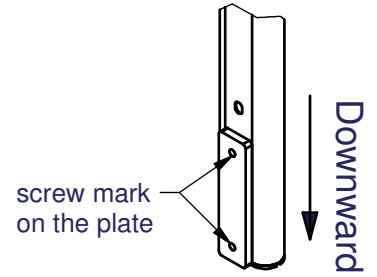

View B

**NOTE :**  
DO NOT tighten screws A10, A13 till PAGE 13

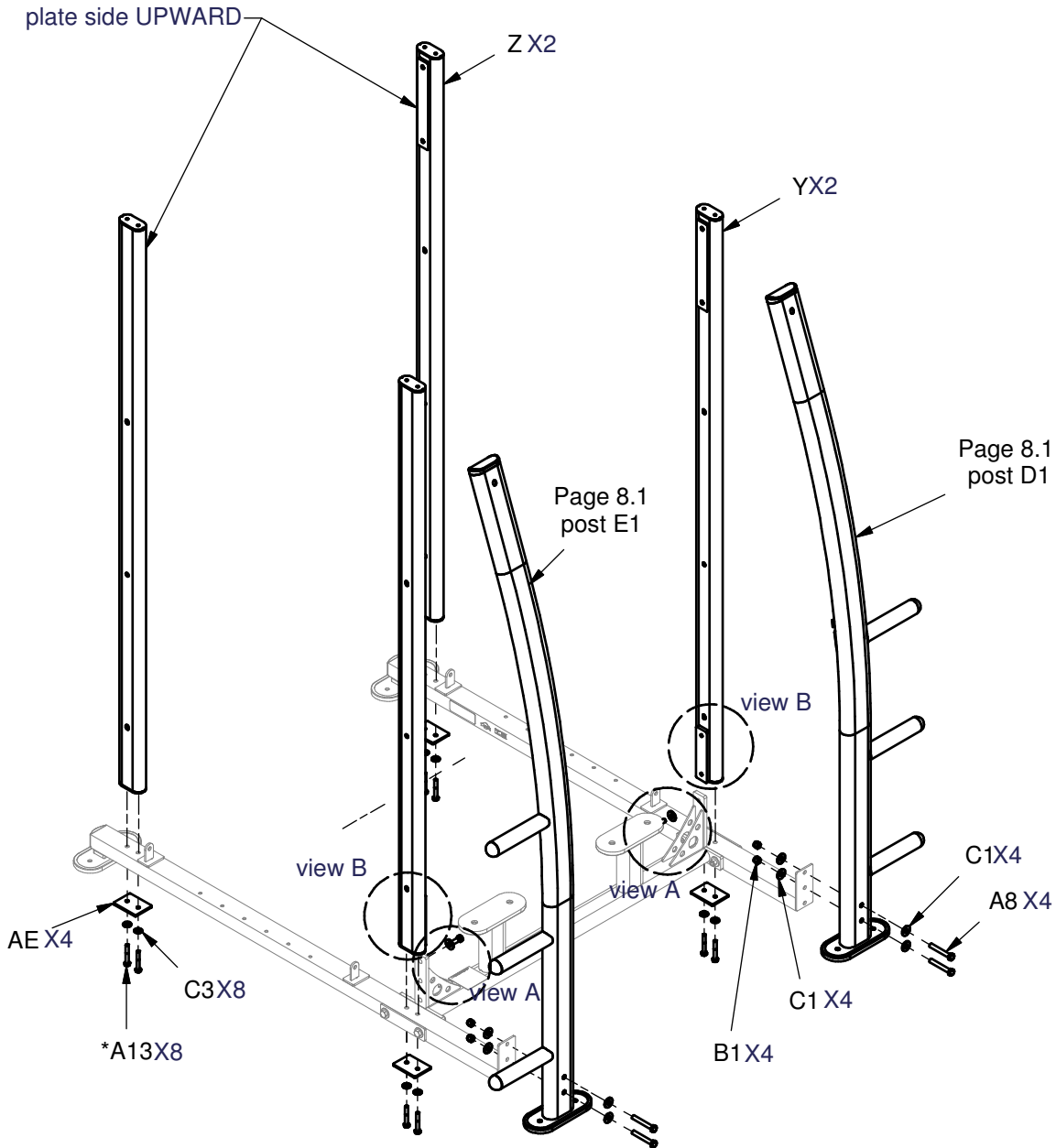

# M3DSM ASSEMBLY INSTRUCTIONS

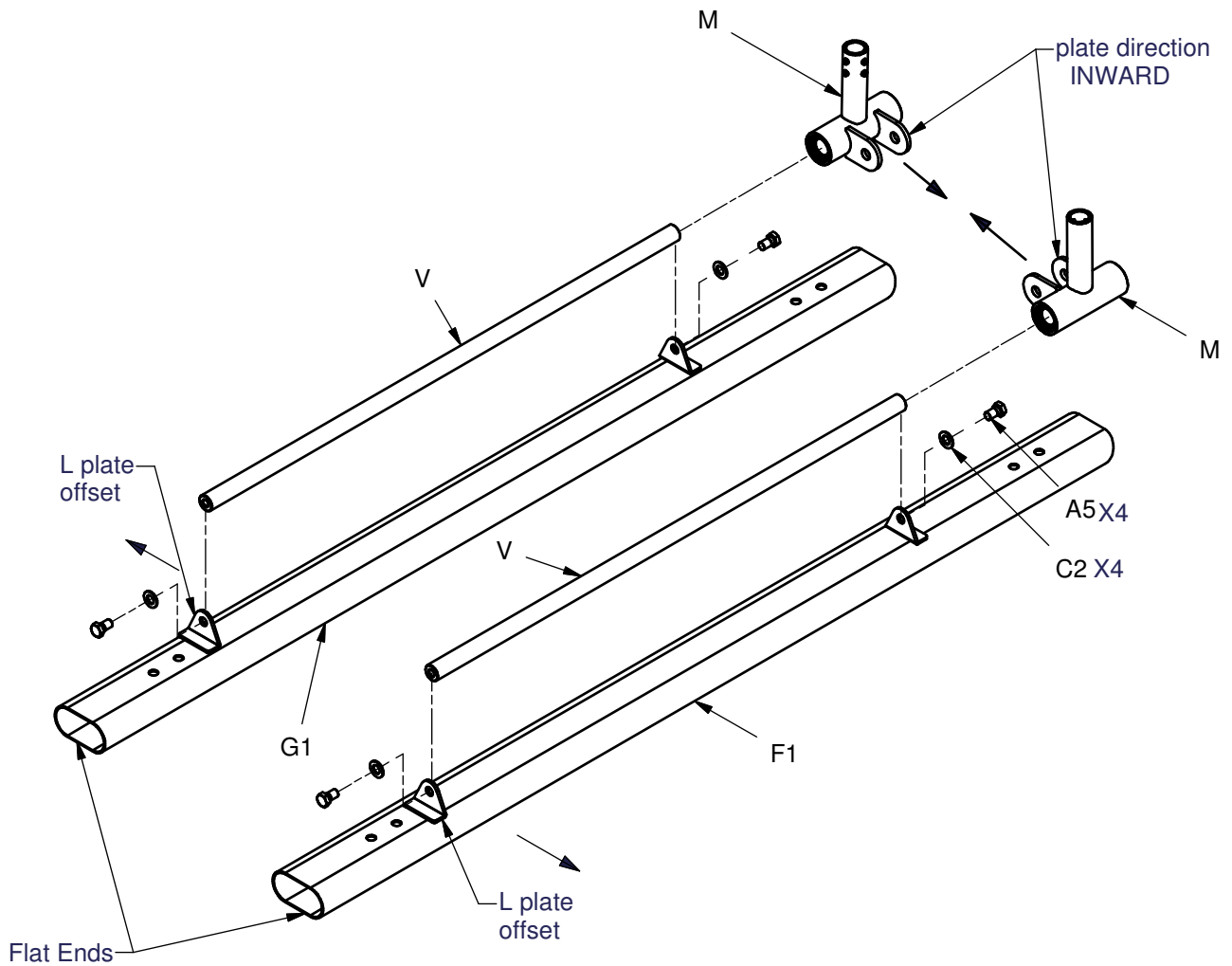
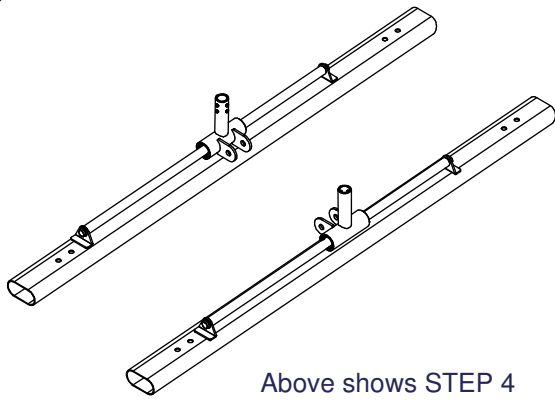

# M3DSM ASSEMBLY INSTRUCTIONS

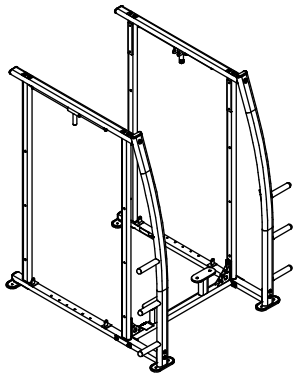

Above shows STEP 5 assembled and completed

**NOTE**  
DO NOT tighten screws A2, A13 till PAGE 13

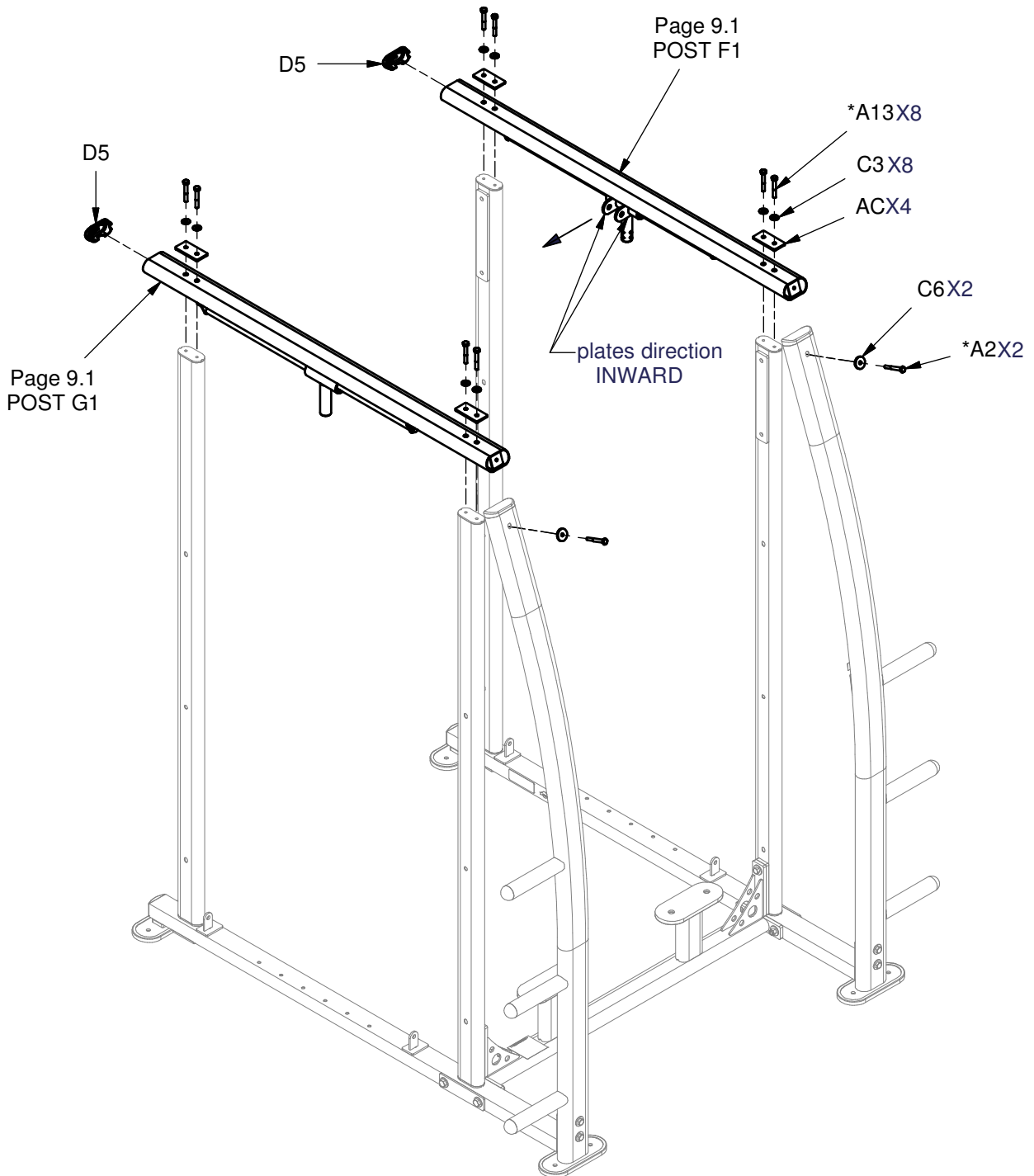

# M3DSM ASSEMBLY INSTRUCTIONS

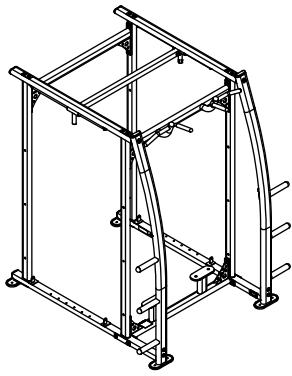

Above shows STEP 6  
assembled and completed

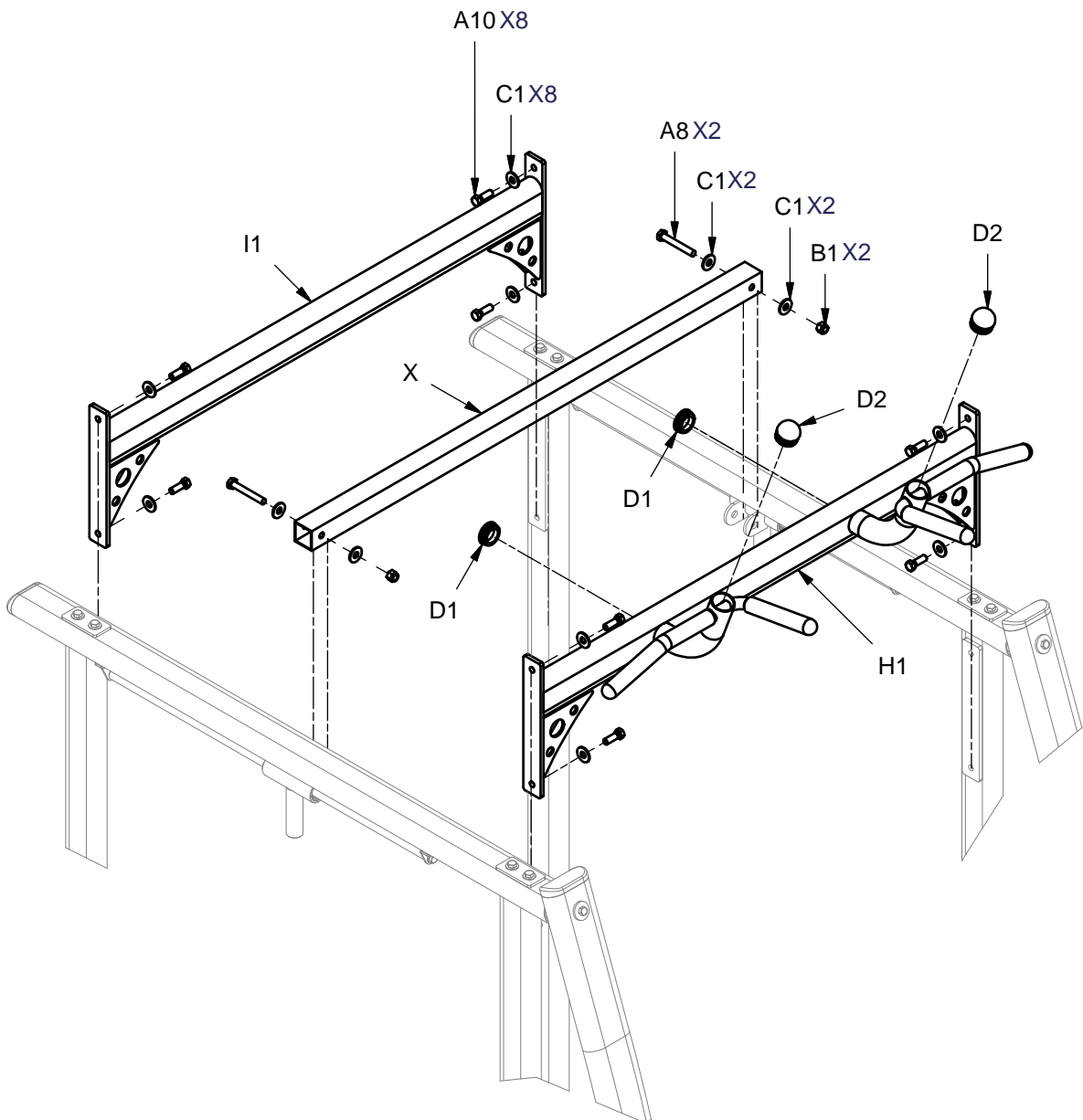

# M3DSM ASSEMBLY INSTRUCTIONS

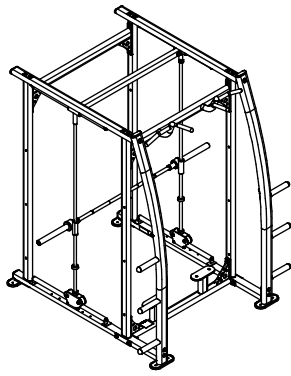

Above shows STEP 7 assembled and completed

tighten 5/16"X3/4"L round allen head screws X 4 pcs

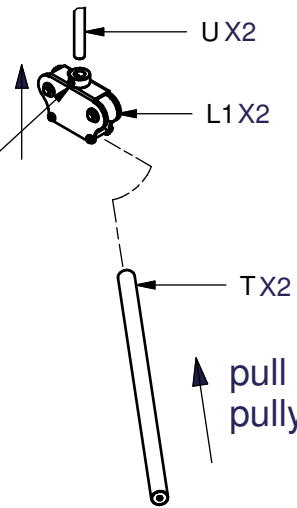

pull bars T into pulley sets L1

- Note
1. push bars U upward during assembly
  2. push pulley sets L1 upward during assembly

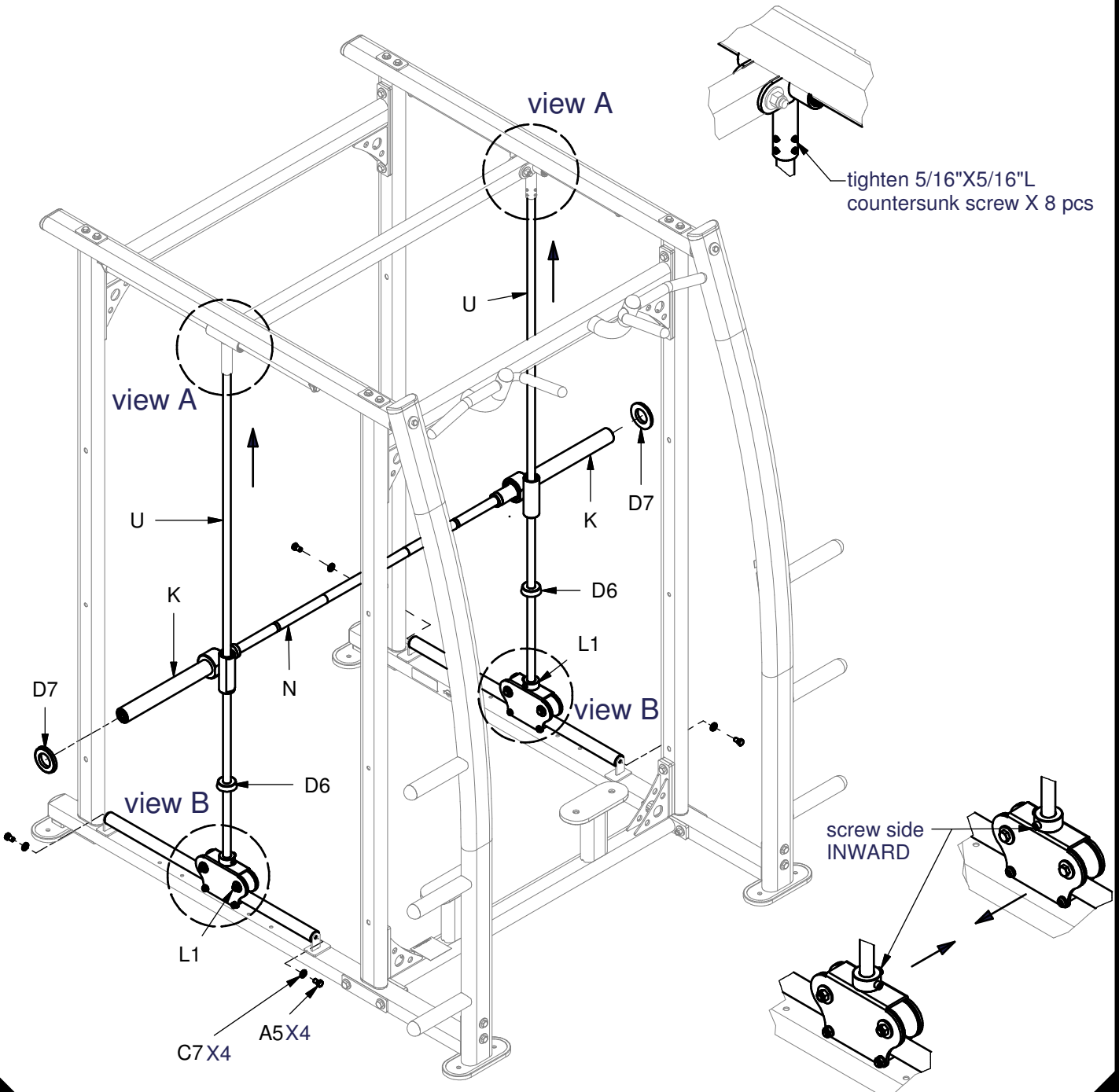



# M3DSM ASSEMBLY INSTRUCTIONS

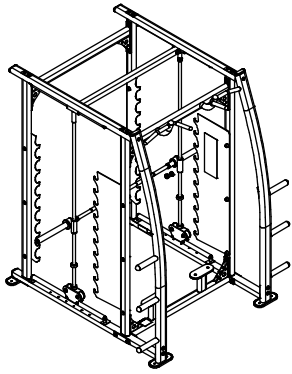

Above shows STEP 8  
assembled and completed

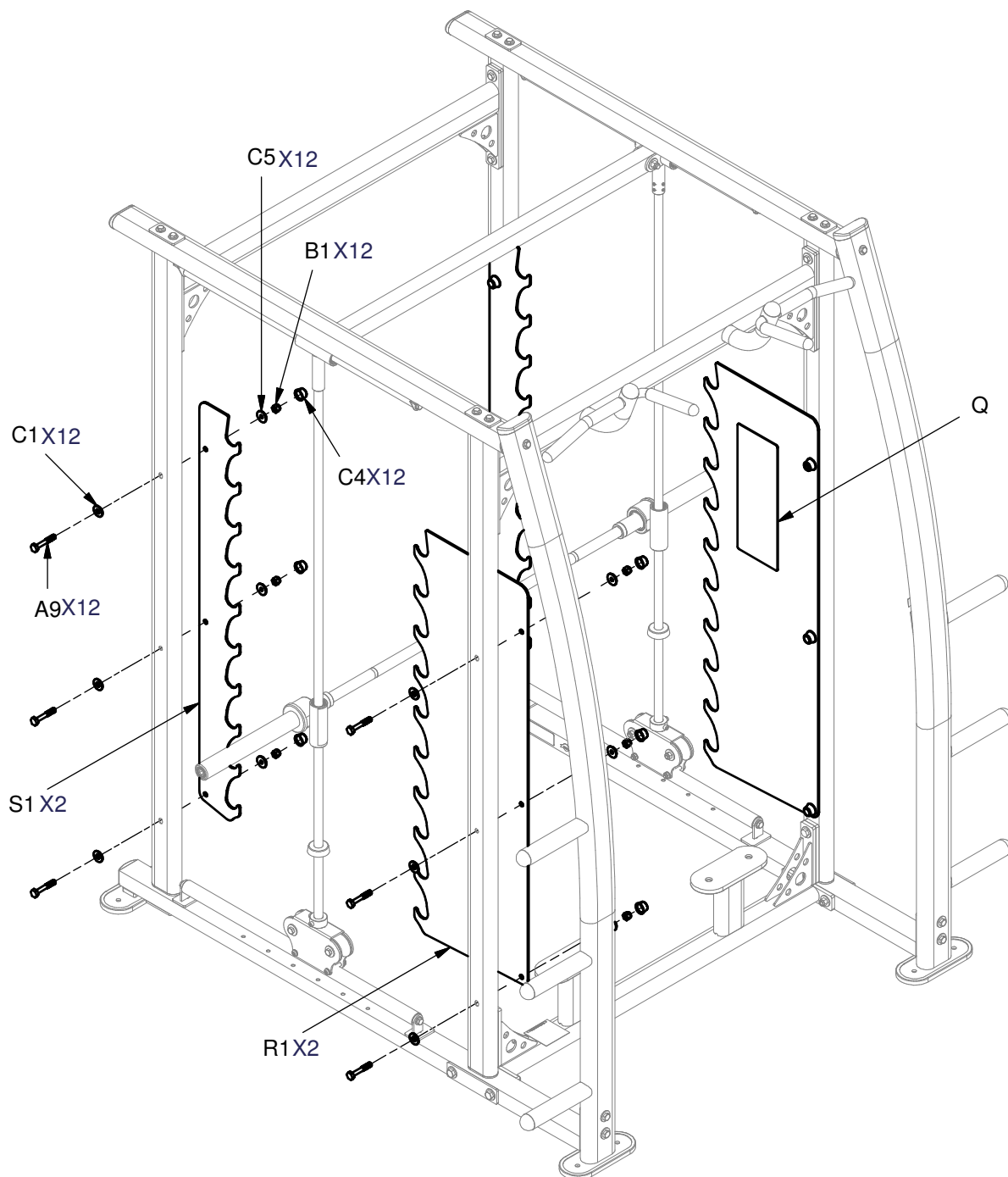

# M3DSM ASSEMBLY INSTRUCTIONS

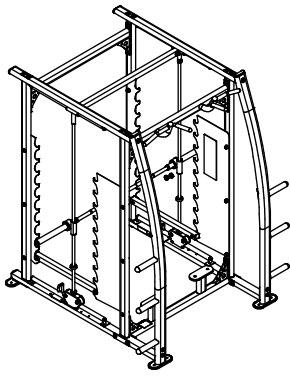

Above shows STEP 9 assembled and completed

Detail view

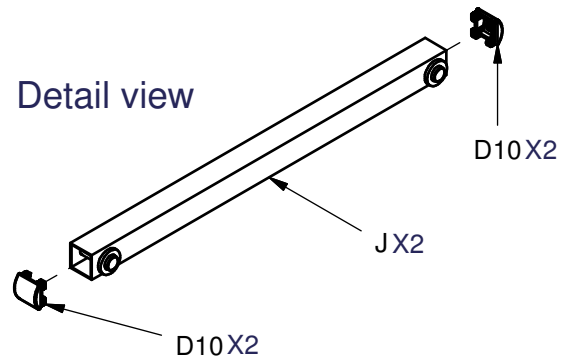

## NOTE

1. placing bars J on location A, B , checking GAP and TIGHTNESS between plates
2. aligning bars Y, Z to balance the GAP and TIGHTNESS
3. tighten screws A10, A13 on page 8.2, screws A2, A13 on page 9.2

